

ITEM NO.	PART NUMBER	DESCRIPTION	QTY.
1	55 PCT	REFERENCE PCAP SCREEN	1
2	20160627-141142-03547594	10-32 SS PEM NUT	9
3	AEHS8-420-165	1/4-20 HEX RIVNUT	8
4	DTS-55-LK-BASE	.25" CRS	1
5	DTS-55-LK-COVER	.06 CRS	1
6	DTS-55-LK-LEGS	2X6X1/8 AL RECT TUBING	1
7	DTS-55-LK-PAN	12GA CRS	1
8	DTS-55-LK-SLANT-1	1/8" AL	1
9	DTS-55-LK-SLANT-2	2X6X1/8 AL RECT TUBING	1
10	DTS-55-LK-SLANT-3	2X6X1/8 AL RECT TUBING	1
11	DTS-55-LK-SLANT-4	1/8" AL	1
12	DTS-SLT-1	.075 CRS	1
13	DTS-SLT-2	.075 CRS	1
14	SS61015-01	1" SS HINGE	2
15	3-13BK01	STANDARD DIGITAL TOUCH LOCK	2

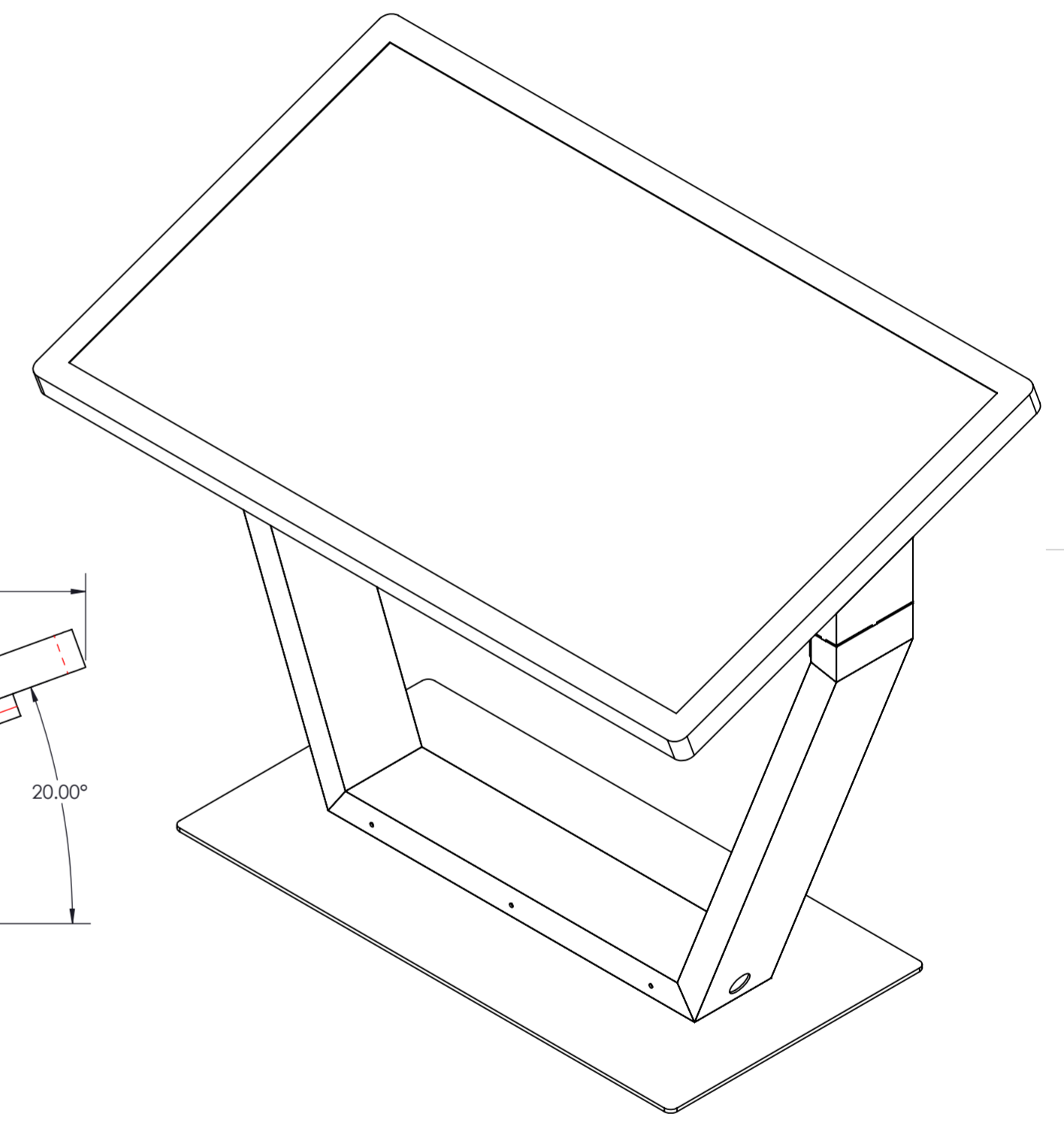

UNLESS OTHERWISE SPECIFIED: DIMENSIONS ARE IN INCHES SURFACE FINISH: TOLERANCES: LINEAR: .01 ANGULAR: .5		FINISH:	DEBUR AND BREAK SHARP EDGES	DO NOT SCALE DRAWING	REVISION
DRAWN:			TITLE:		
CHK'D:			DWG NO. DTS-55-LK		
APP'VD:			A2		
MFG:			SCALE: 1:16		
Q.A.			SHEET 1 OF 6		

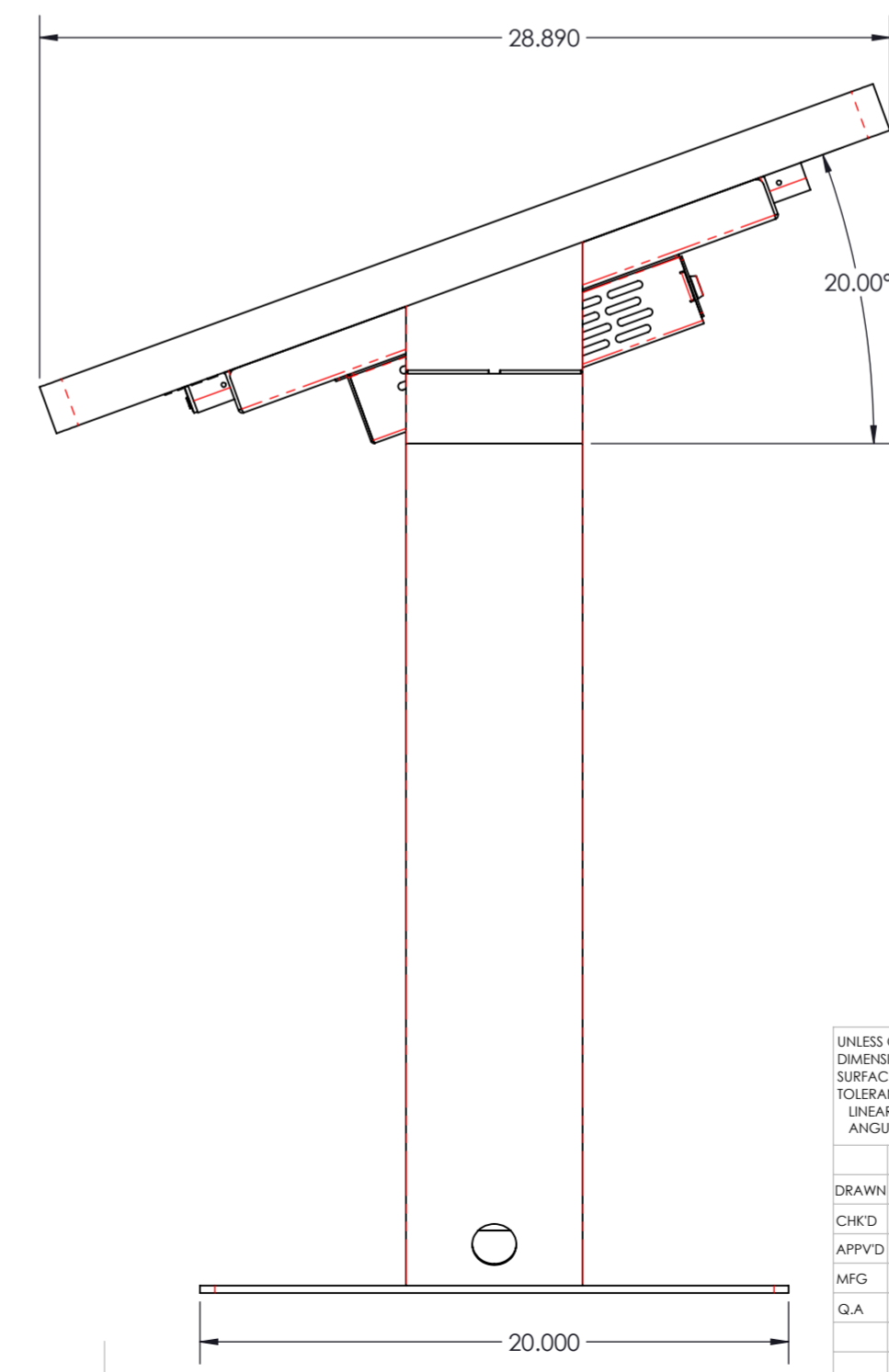
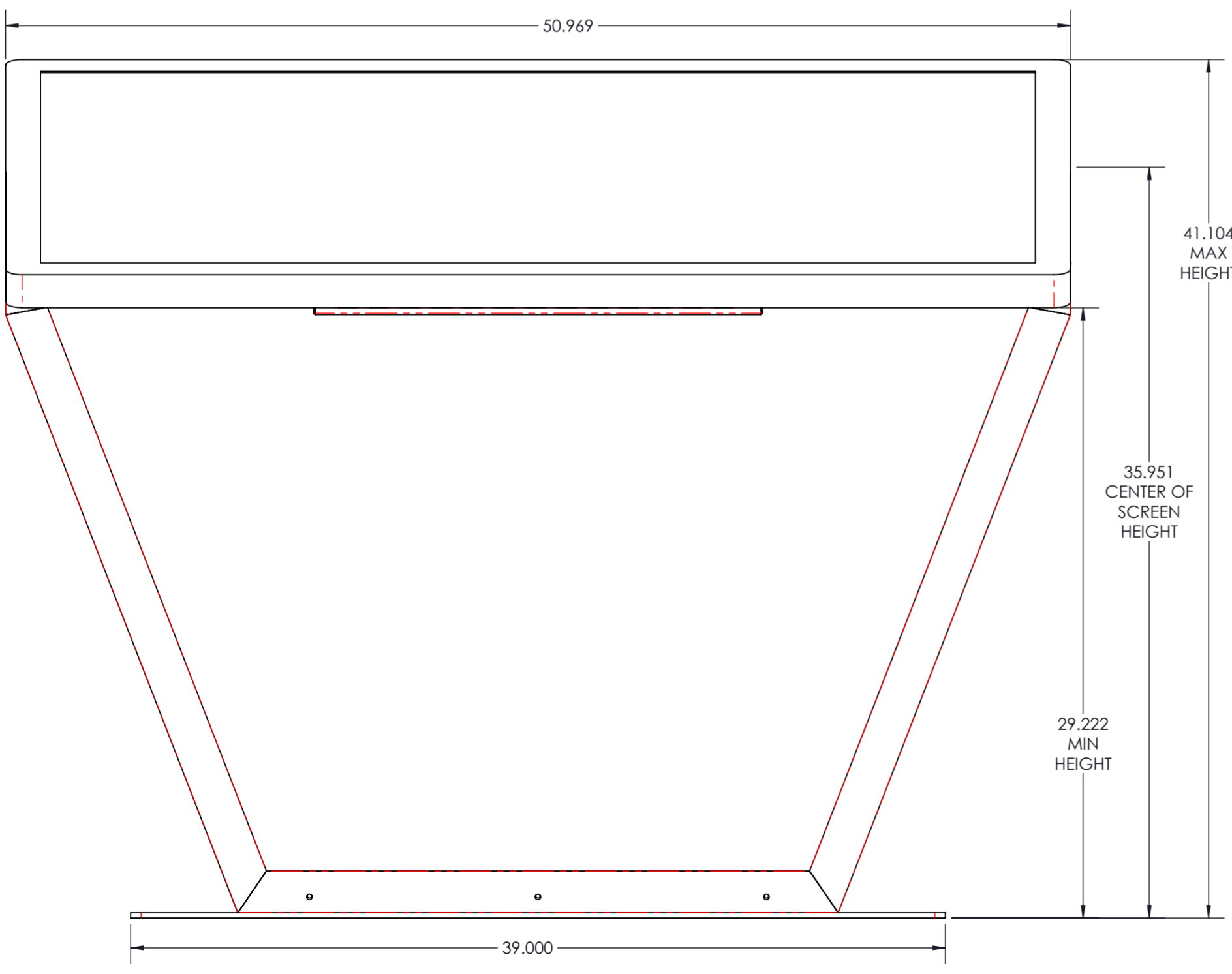
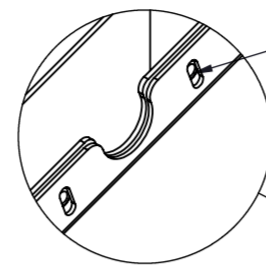

1/4-20 HEX RIVNUT
IN TUBING TO BOLT
PAN INTO. NO NEED
TO REACH INSIDE
TUBING.

DETAIL C
SCALE 1 : 4

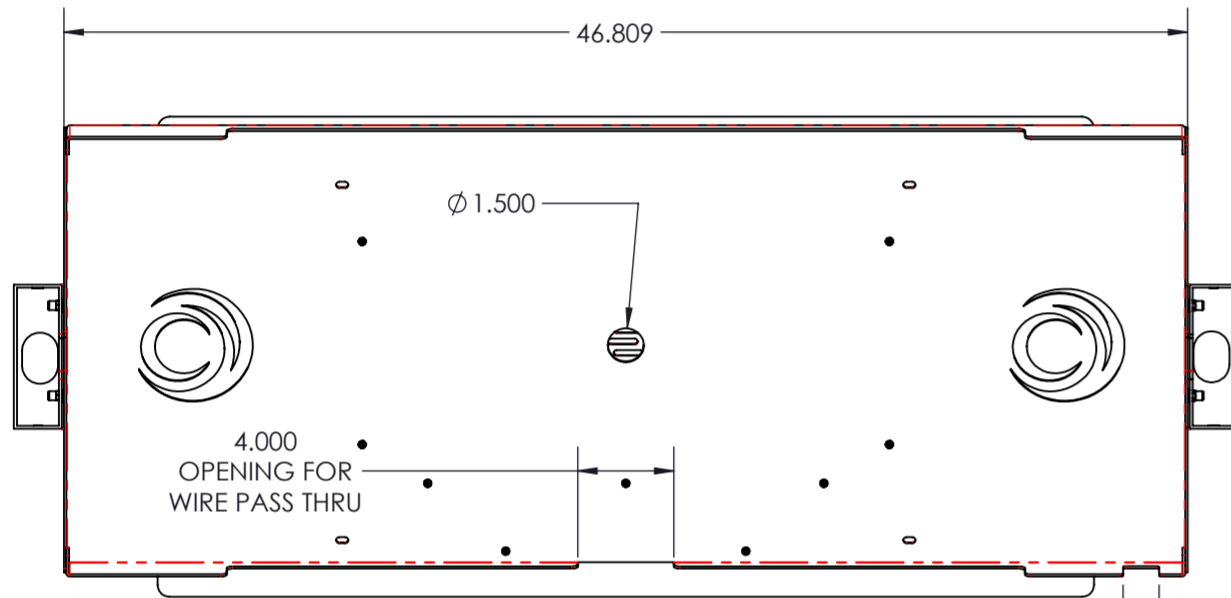

1.500
OPENING FOR
FINGER ACCESS
TO BUTTONS

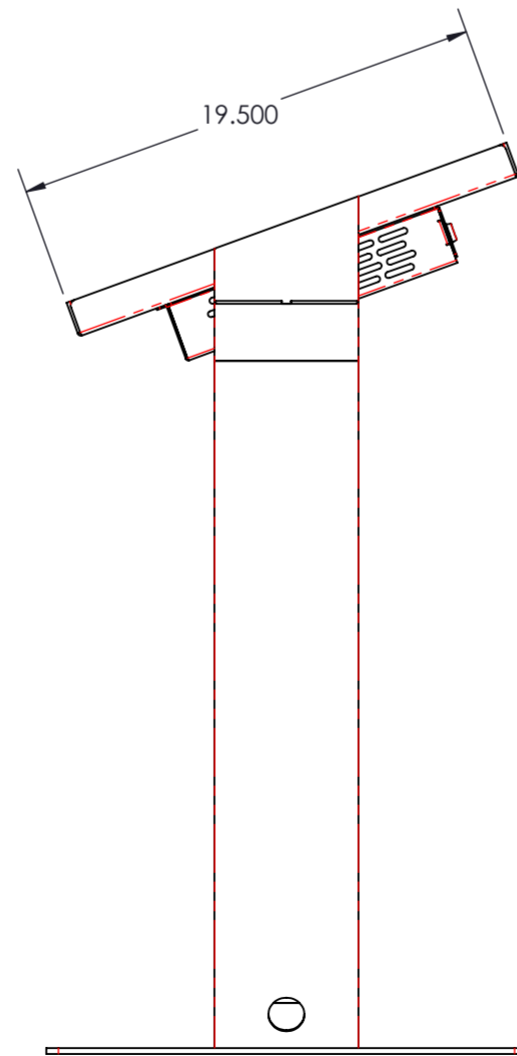
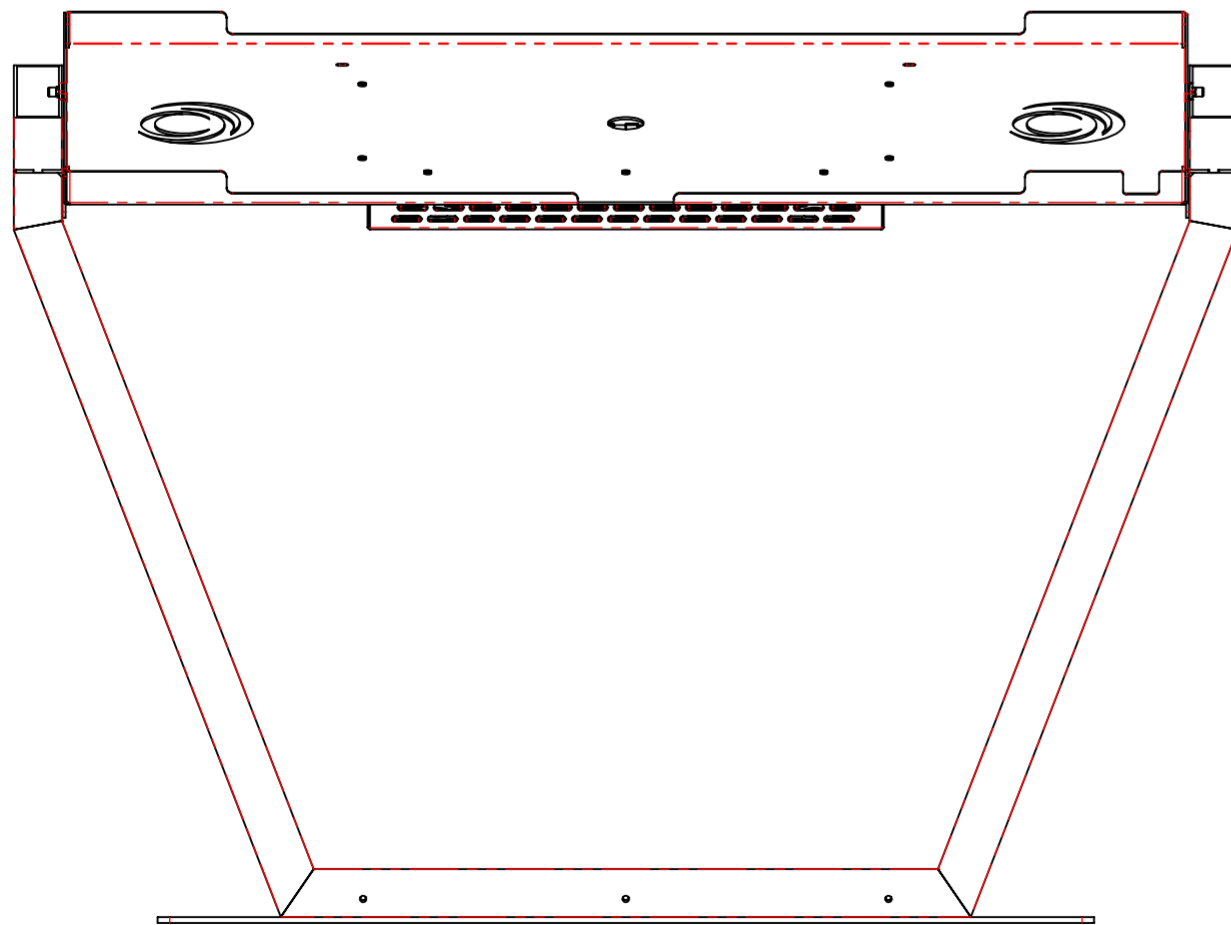
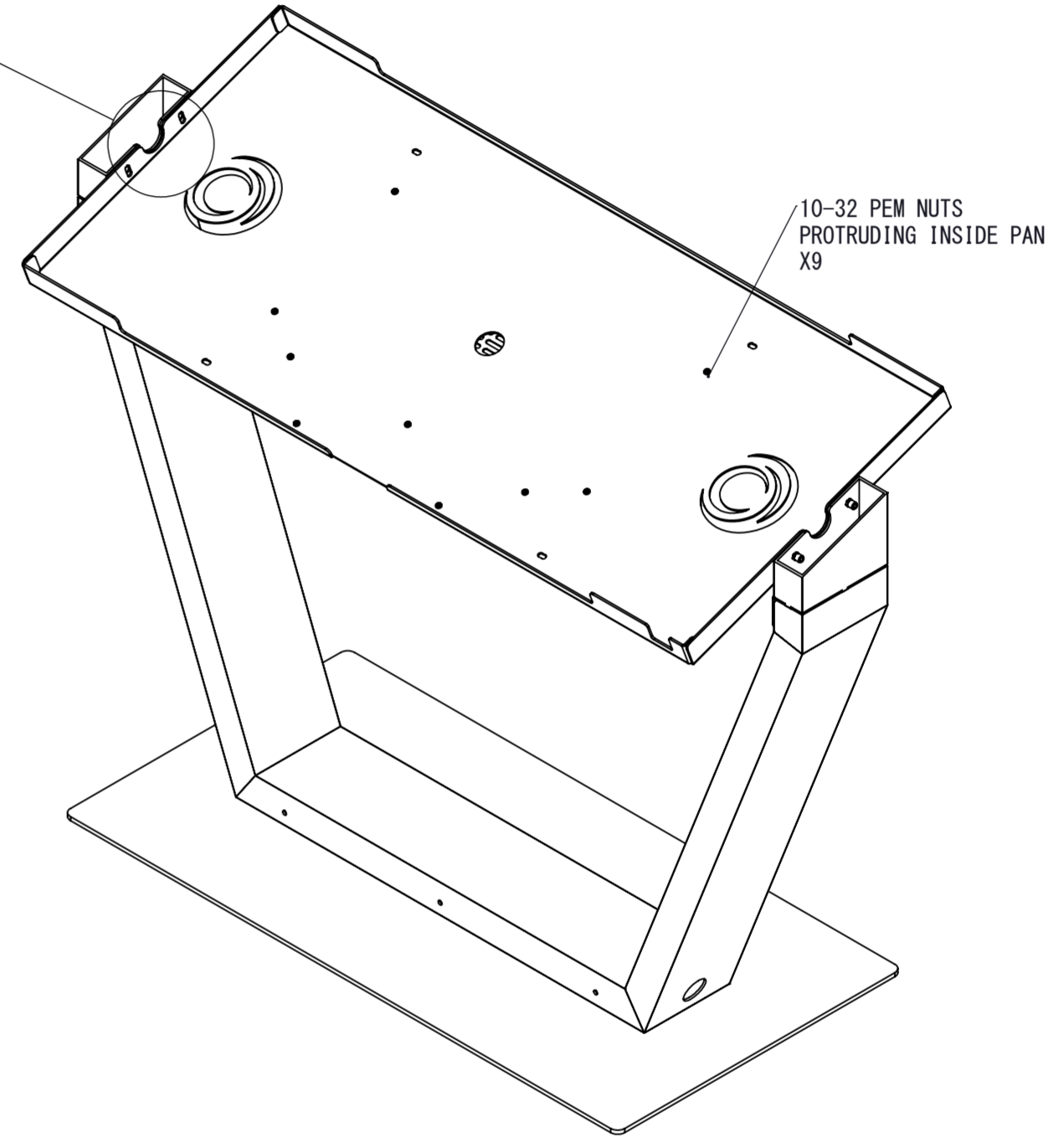

UNLESS OTHERWISE SPECIFIED: DIMENSIONS ARE IN INCHES SURFACE FINISH: TOLERANCES: LINEAR: .01 ANGULAR: .5		FINISH:	DEBUR AND BREAK SHARP EDGES	DO NOT SCALE DRAWING	REVISION
				Digital Touch Systems	
				TITLE:	
DRAWN:	NAME	SIGNATURE	DATE	DWG NO.	DTS-55-LK
CHK'D:					A2
APP'V'D:					
MFG:					
Q.A.				MATERIAL:	
				WEIGHT:	SCALE: 1:16
					SHEET 2 OF 6

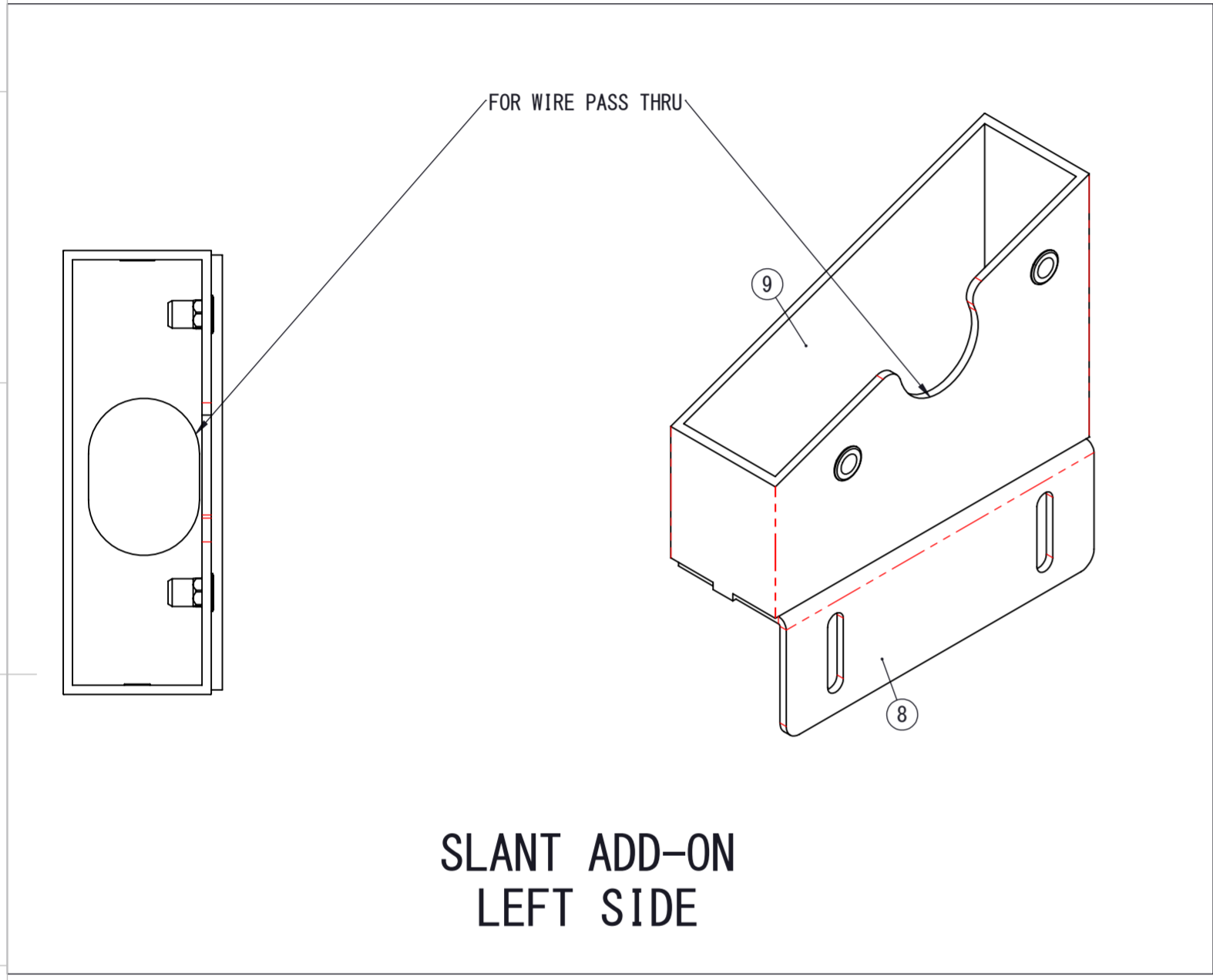

**SLANT ADD-ON
LEFT SIDE**

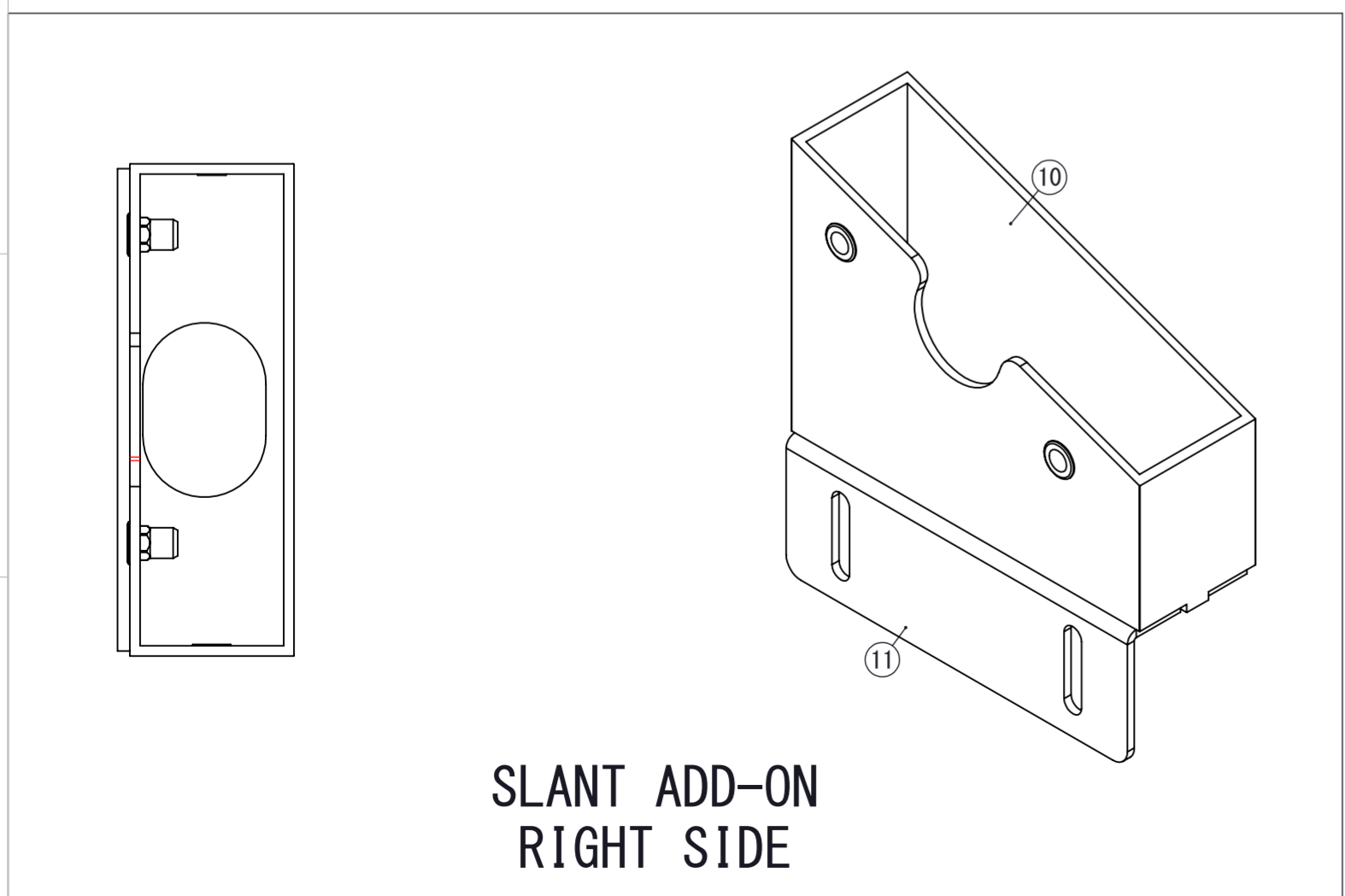

**SLANT ADD-ON
RIGHT SIDE**

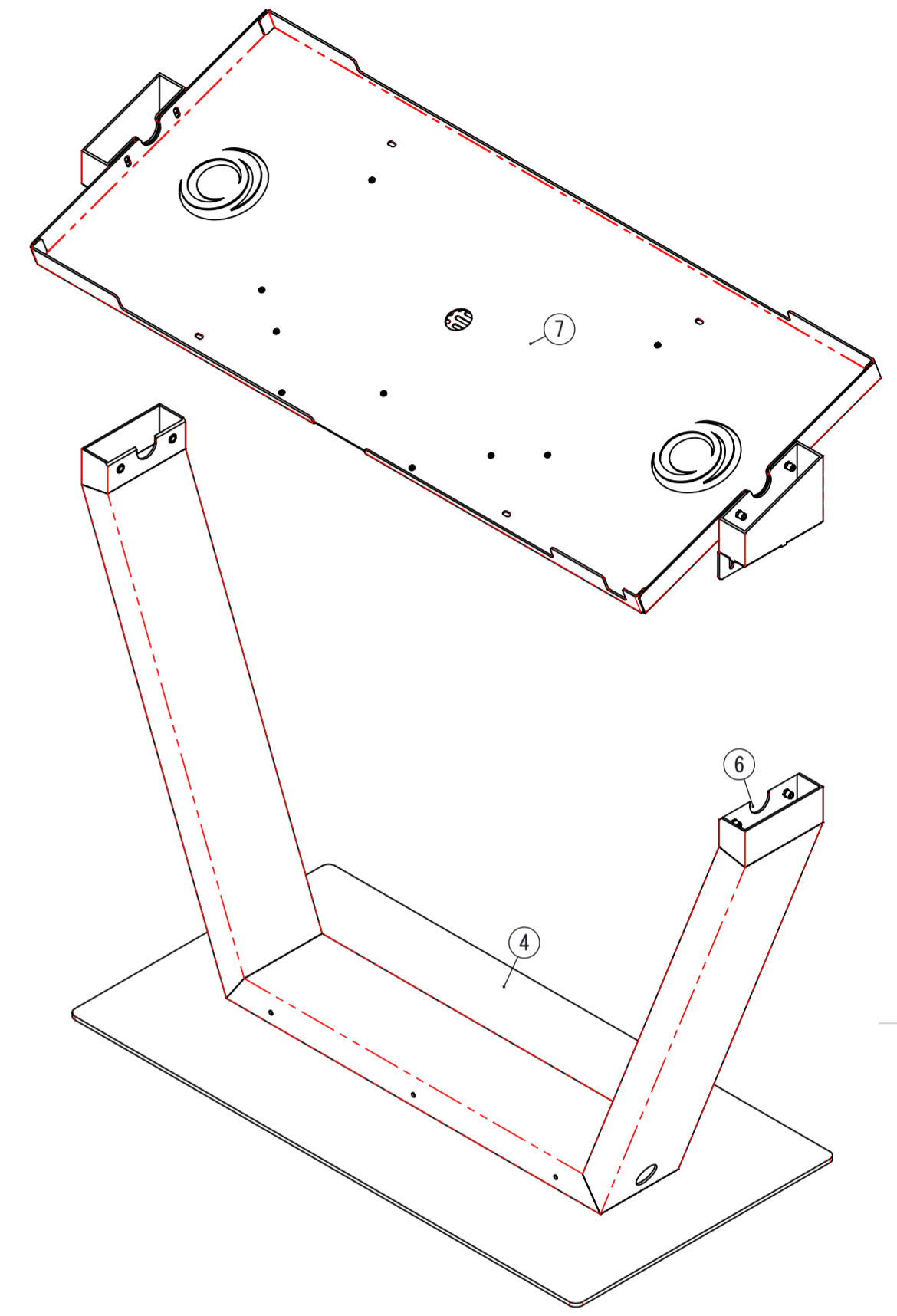
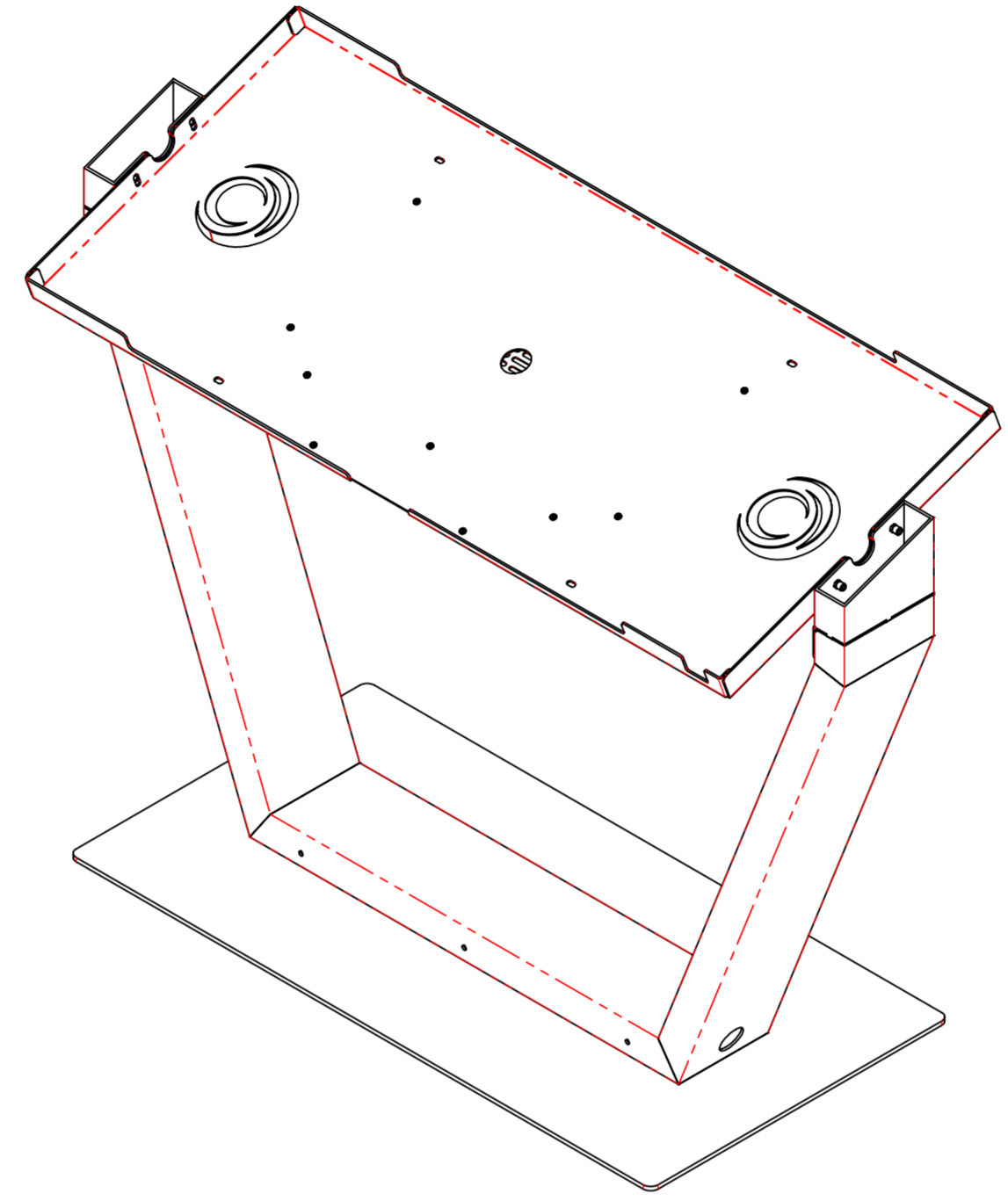

UNLESS OTHERWISE SPECIFIED: DIMENSIONS ARE IN INCHES SURFACE FINISH: TOLERANCES: LINEAR: .01 ANGULAR: .5		FINISH:	DEBUR AND BREAK SHARP EDGES		DO NOT SCALE DRAWING	REVISION
				Digital Touch Systems		
DRAWN:		NAME	SIGNATURE	DATE	TITLE:	
CHK'D:						
APP'V'D:						
MFG:						
Q.A.				MATERIAL:	DWG NO.	DTS-55-LK
				WEIGHT:	SCALE: 1:16	A2
					SHEET 3 OF 6	

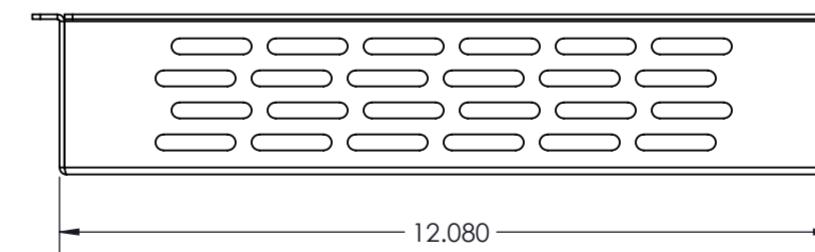
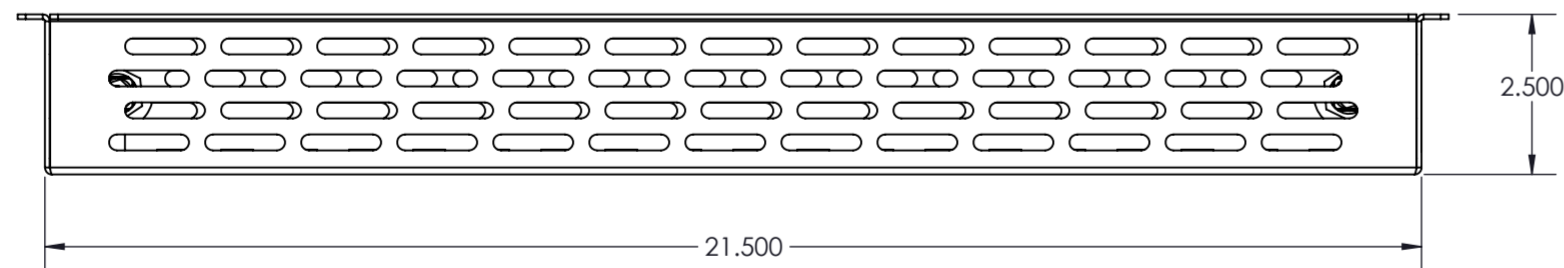
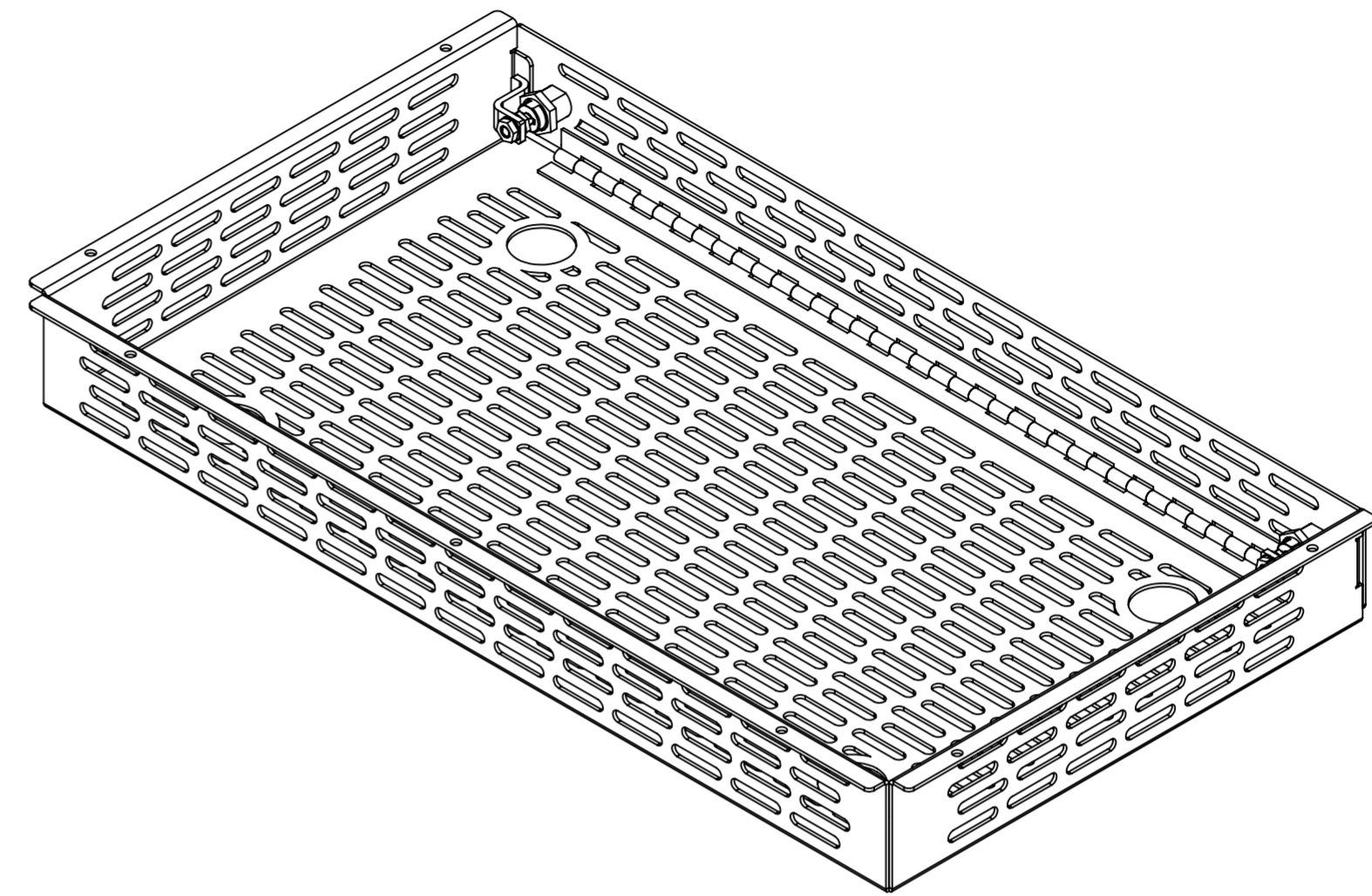
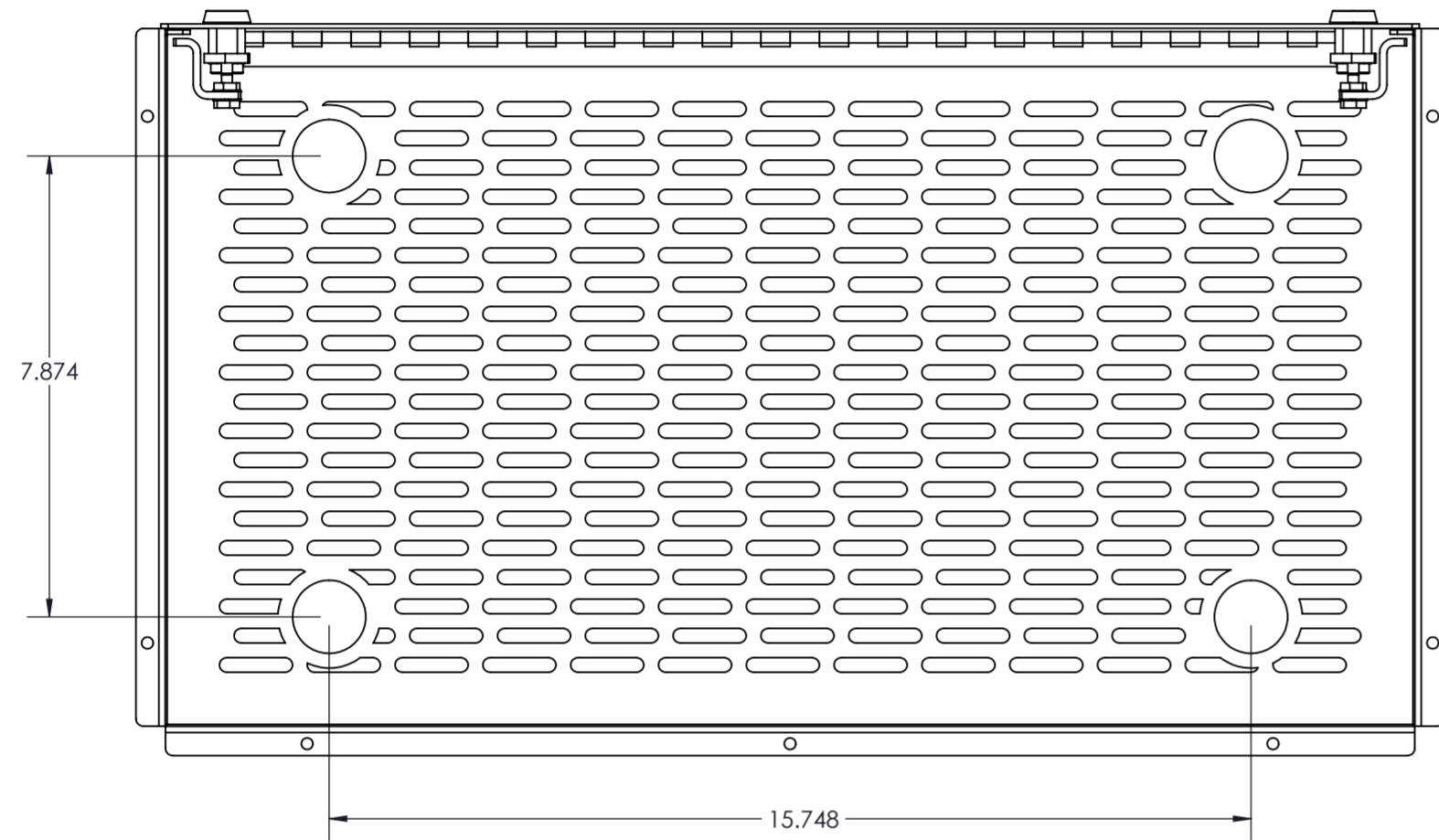

UNLESS OTHERWISE SPECIFIED: DIMENSIONS ARE IN INCHES SURFACE FINISH: TOLERANCES: LINEAR: .01 ANGULAR: .5				FINISH:		DEBUR AND BREAK SHARP EDGES		DO NOT SCALE DRAWING		REVISION	
								Digital Touch Systems			
								TITLE:			
DRAWN:		NAME		SIGNATURE		DATE					
CHK'D:											
APP'VD:											
MFG:											
Q.A:								MATERIAL:		DWG NO. DTS-55-LK	
								WEIGHT:		SCALE: 1:8	
										SHEET 4 OF 6	
										A2	