

ITEM NO.	PART NUMBER	DESCRIPTION	QTY.
1	DTS-65-LKN-BASE	.25" CRS	1
2	DTS-65-LKN-COVER	.06 CRS	1
3	DTS-65-LKN-LEGS-CRS	2X6X0.075" CRS RECT TUBING	1
4	DTS-65-LKN-PAN	12GA CRS	1
5	DTS-65-LKN-SLANT-1-CRS	11GA CRS	1
6	DTS-65-LKN-SLANT-3-CRS	2X6X0.075" CRS RECT TUBING	1
7	DTS-65-LKN-SLANT-2-CRS	2X6X0.075" CRS RECT TUBING	1
8	DTS-65-LKN-SLANT-4-CRS	11GA CRS	1
9	20160627-141142-03547594	10-32 SS PEM NUT	9
10	AEHS8-420-165	1/4-20 HEX RIVNUT	8
11	DTS-SLT-1	.075 CRS	1
12	DTS-SLT-2	.075 CRS	1
13	SS61015-01	1" SS HINGE	2
14	3-13BK01	STANDARD DIGITAL TOUCH LOCK	2
21	NEP650-003	CUSTOMER REFERENCED PART	1

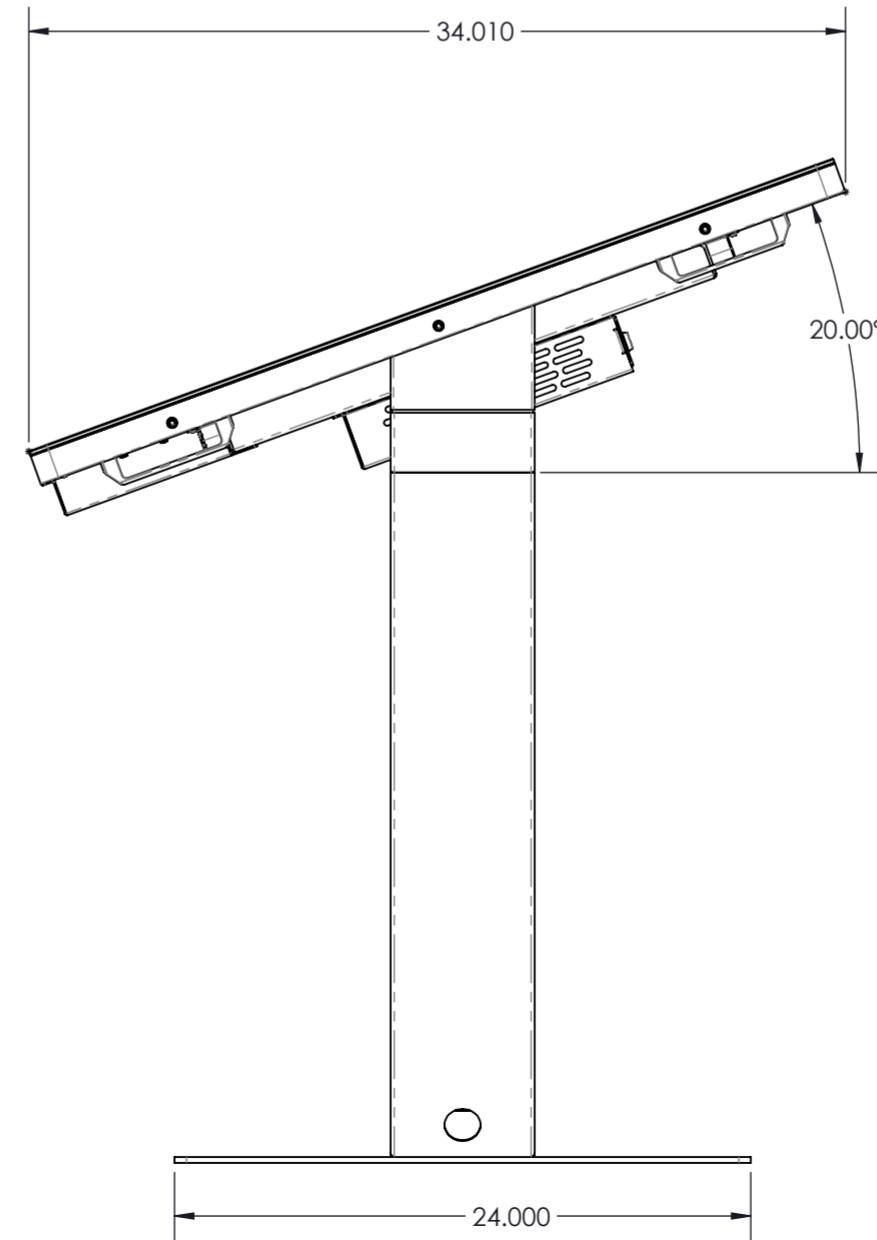

UNLESS OTHERWISE SPECIFIED: DIMENSIONS ARE IN INCHES SURFACE FINISH: TOLERANCES: LINEAR: .01 ANGULAR: .5		FINISH:	DEBUR AND BREAK SHARP EDGES	DO NOT SCALE DRAWING	REVISION
DRAWN:			TITLE:		
CHK'D:			DWG NO. <b>DTS-65-LKN</b>		
APP'VD:			SCALE: 1:16		
MFG:			SHEET 1 OF 6		
Q.A.			A2		
MATERIAL:			WEIGHT:		

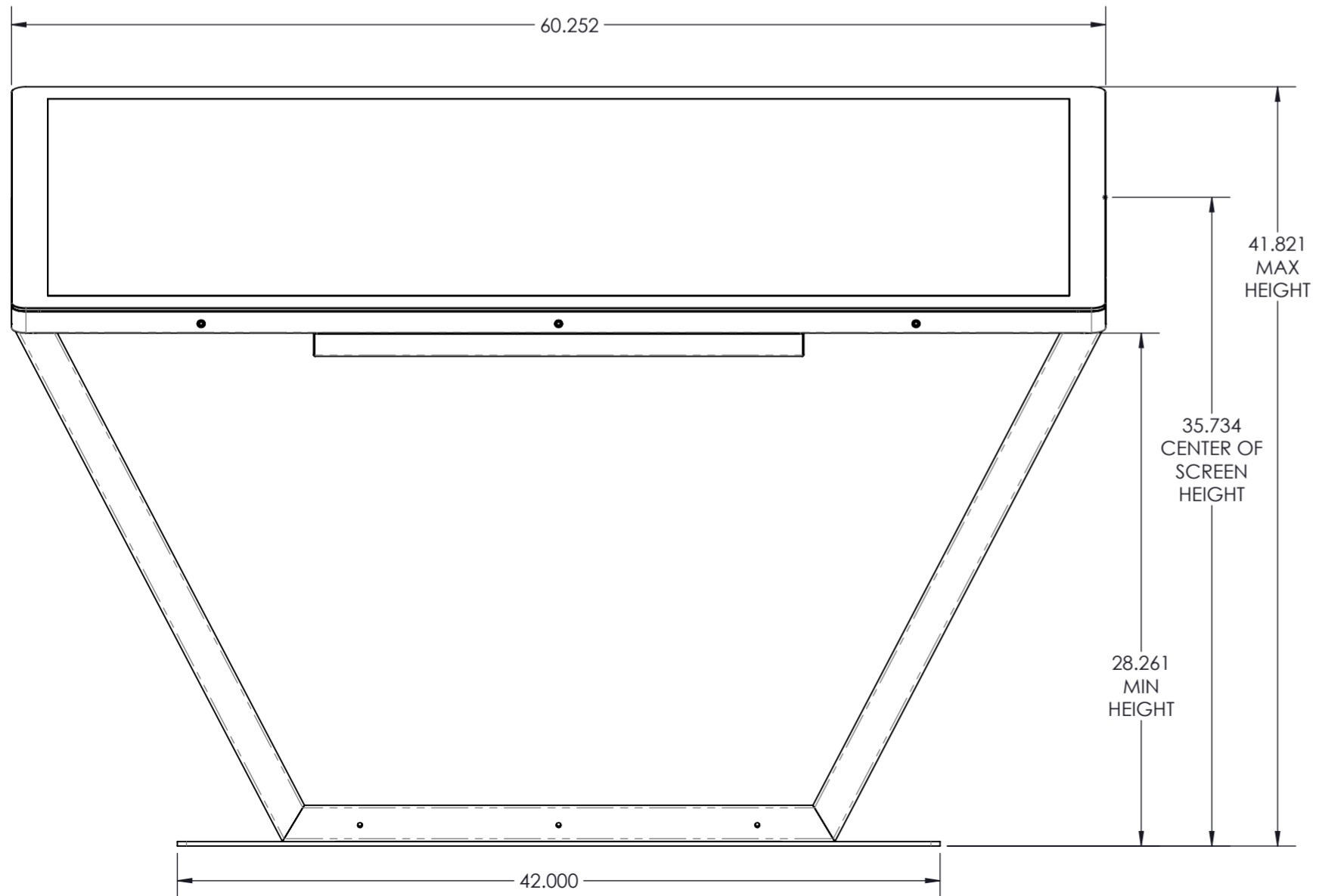
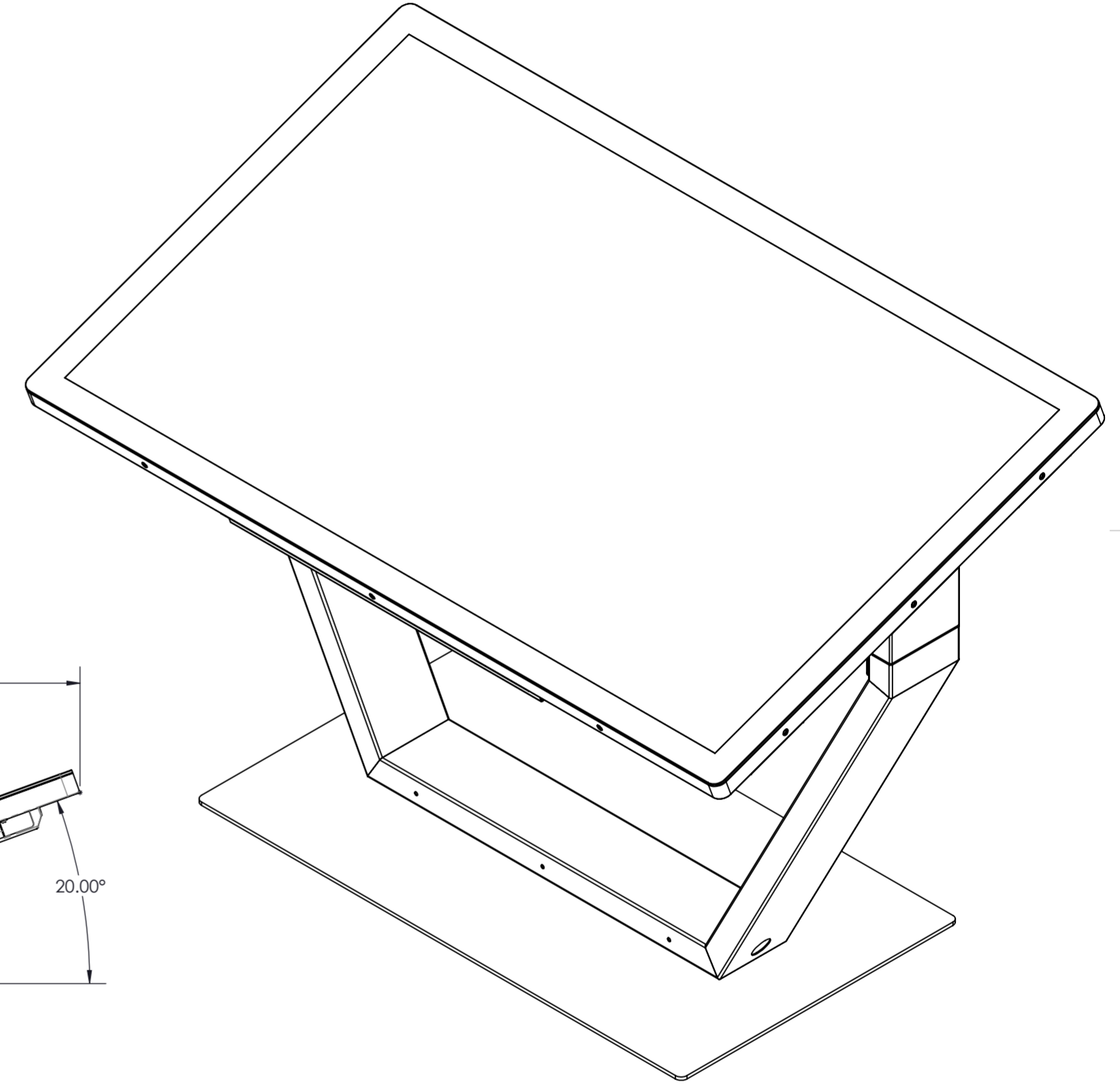
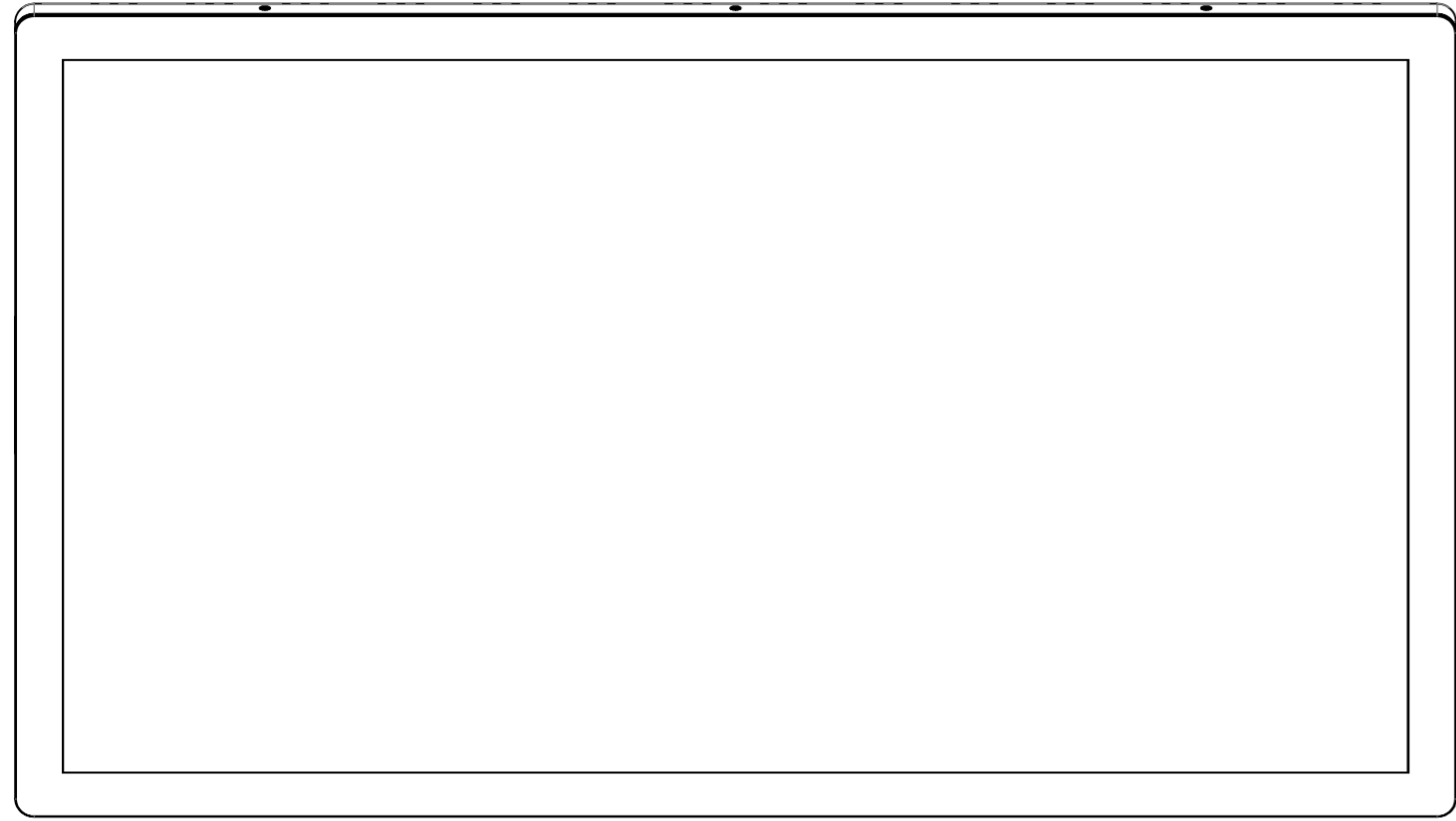
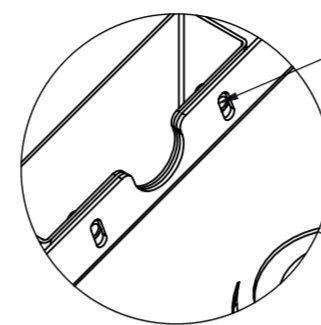

1/4-20 HEX RIVNUT  
IN TUBING TO BOLT  
PAN INTO. NO NEED  
TO REACH INSIDE  
TUBING.

DETAIL C  
SCALE 1 : 4

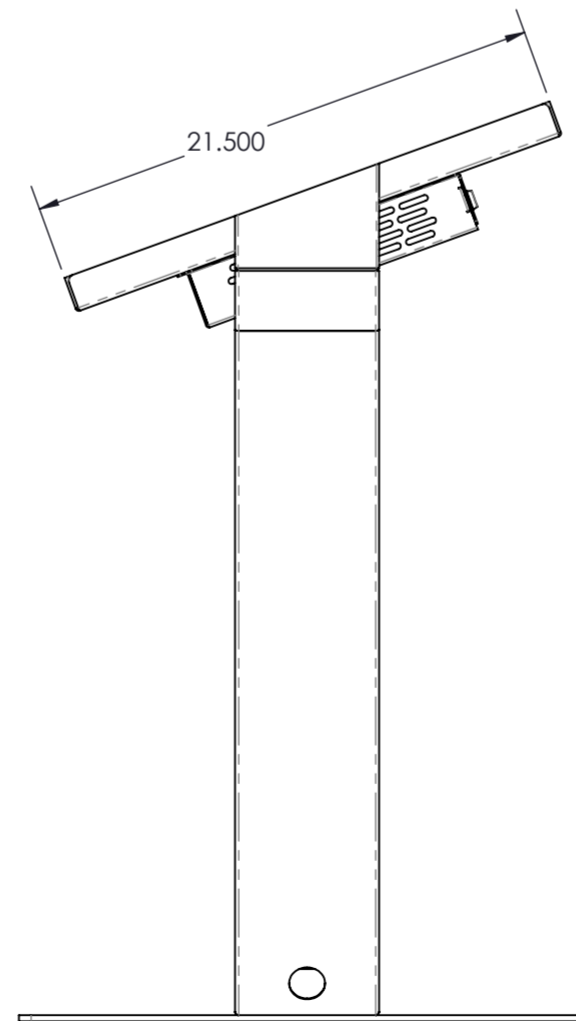
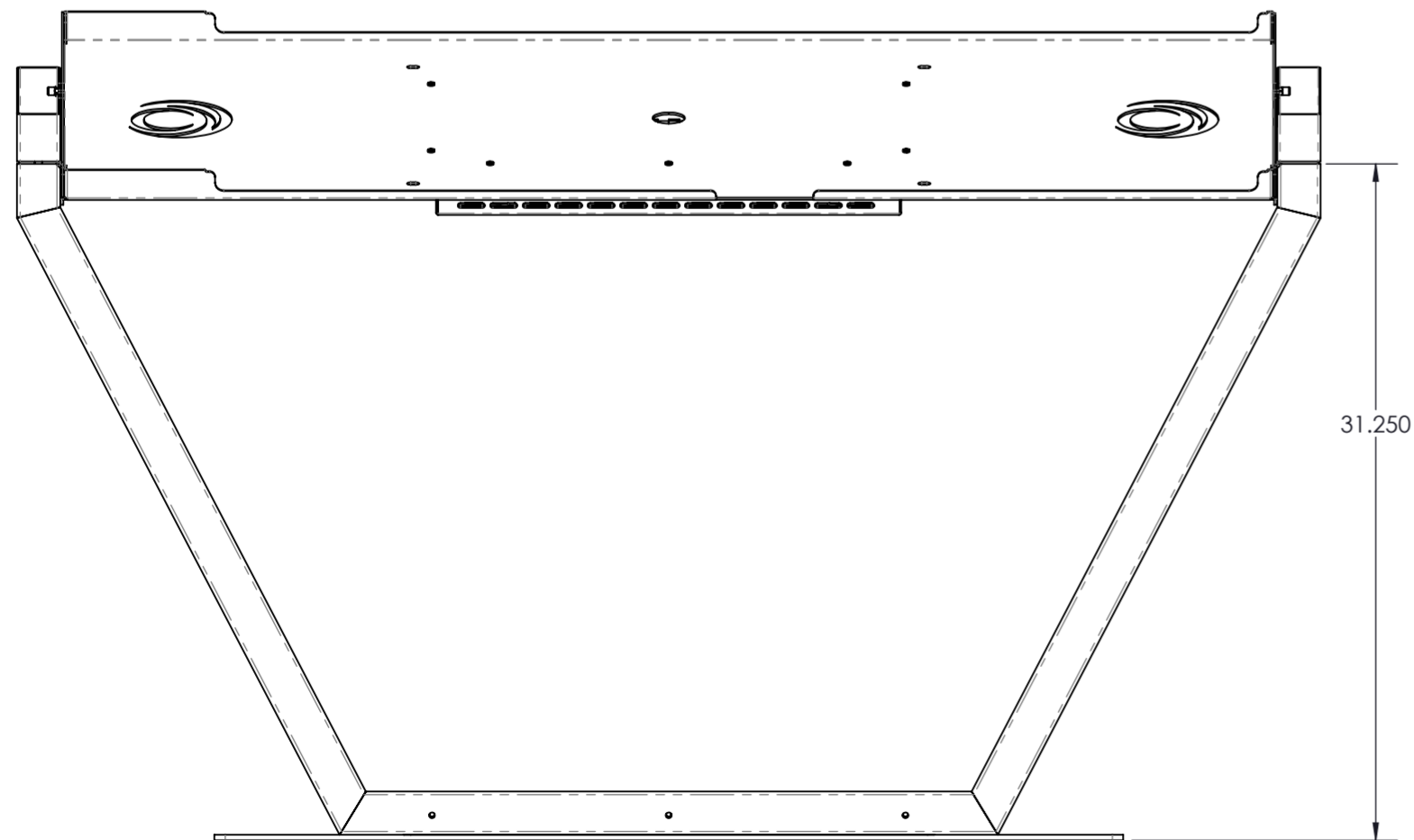
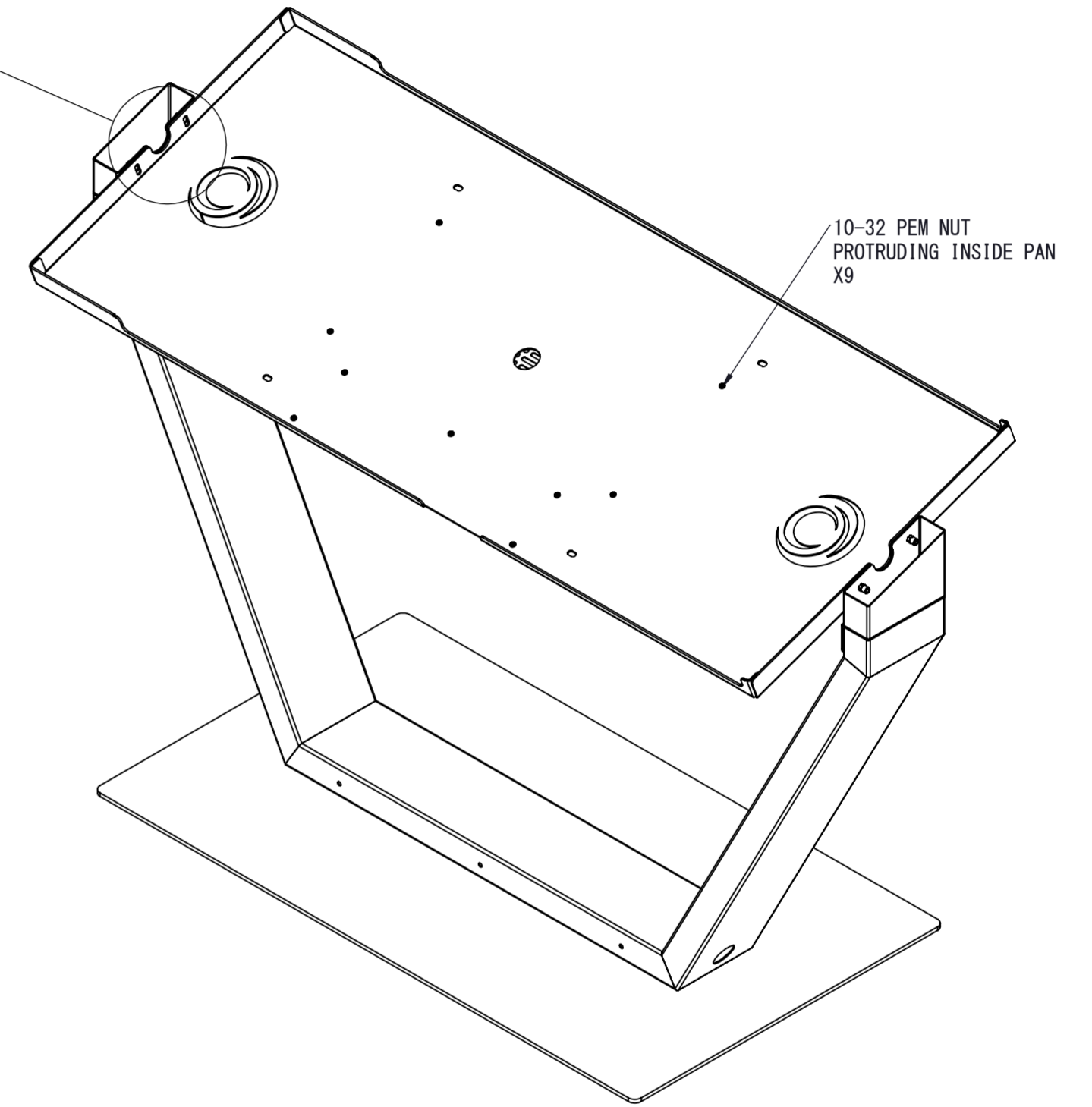
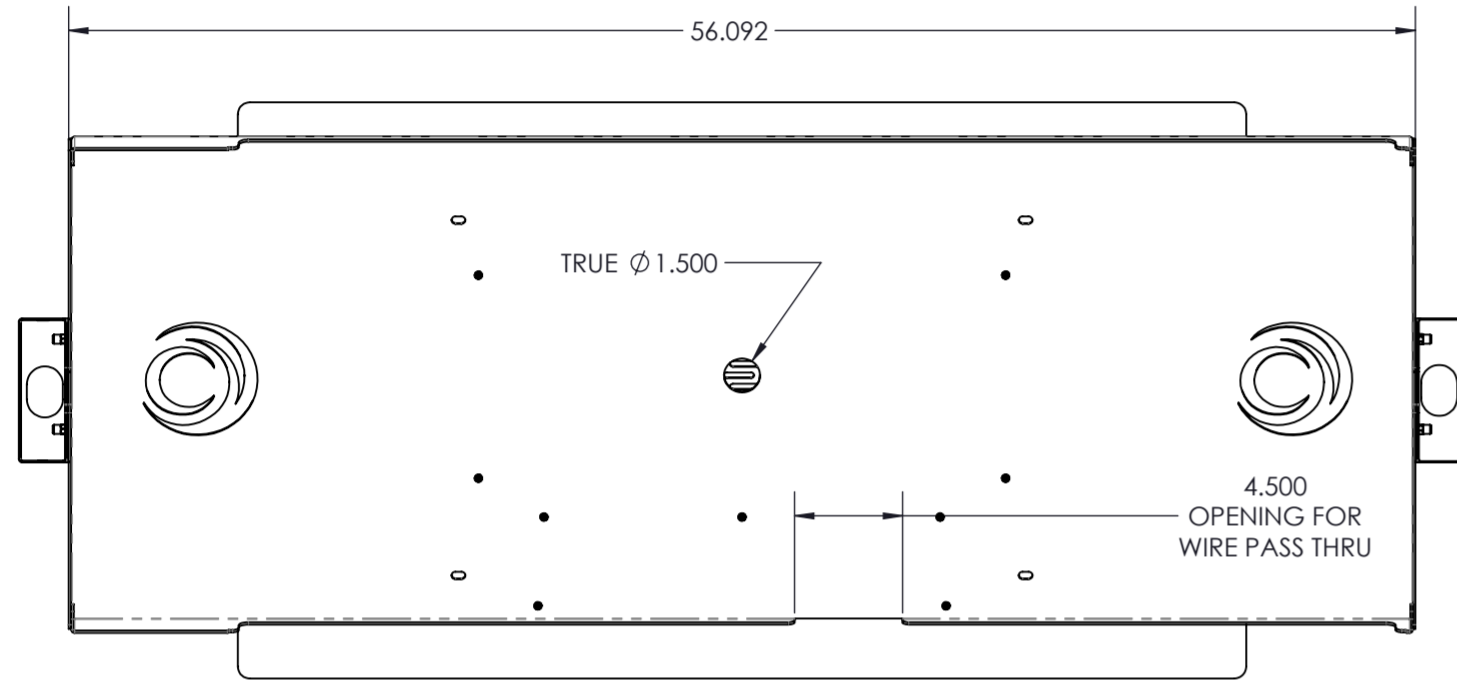

UNLESS OTHERWISE SPECIFIED: DIMENSIONS ARE IN INCHES SURFACE FINISH: TOLERANCES: LINEAR: .01 ANGULAR: .5		FINISH:	DEBUR AND BREAK SHARP EDGES	DO NOT SCALE DRAWING	REVISION
				<b>Digital Touch Systems</b>	
DRAWN:		NAME	SIGNATURE	DATE	TITLE:
CHK'D:					
APP'V'D:					
MFG:					
Q.A.					
		MATERIAL:		DWG NO.	A2
		WEIGHT:		SCALE: 1:16	SHEET 2 OF 6

DTS-65-LKN

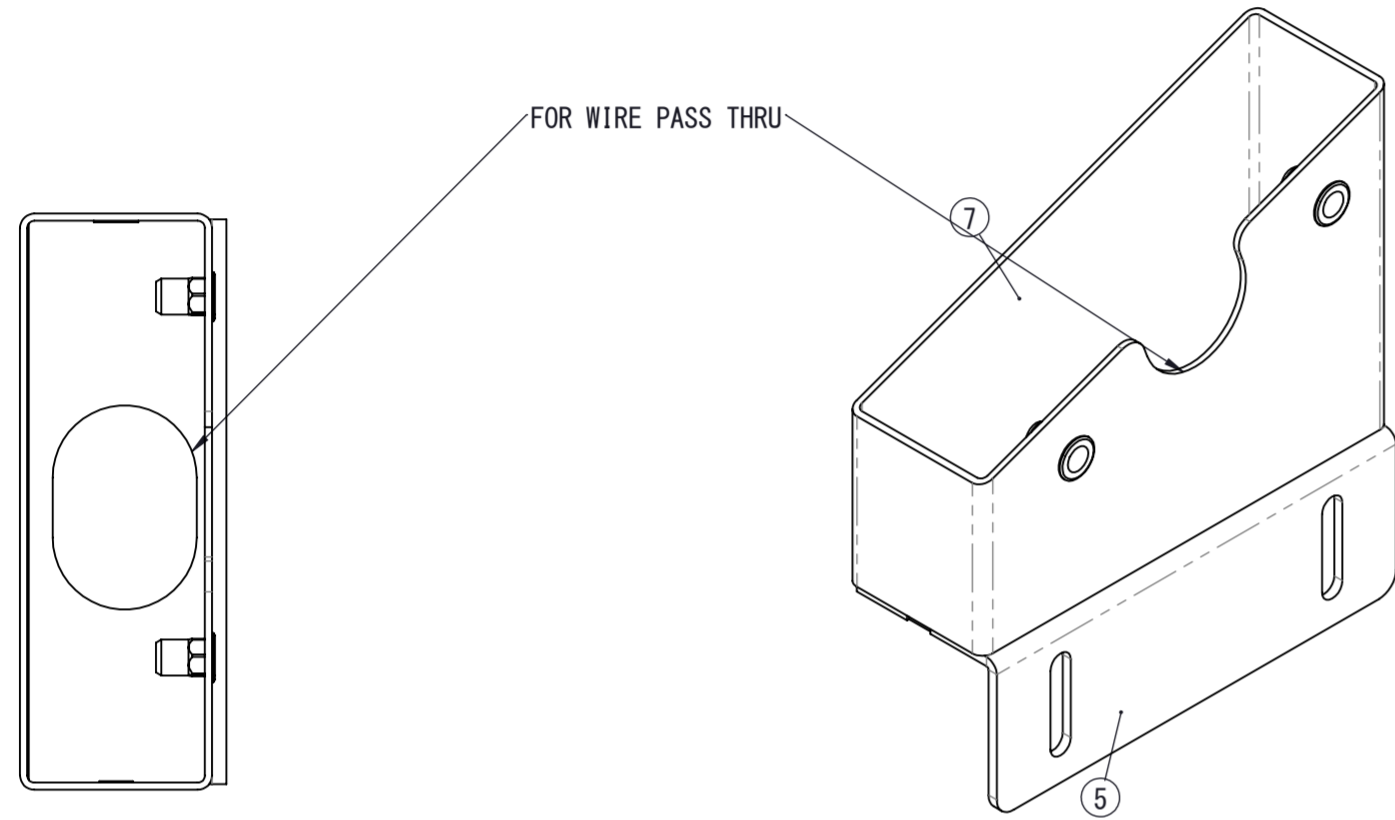

**SLANT ADD-ON  
LEFT SIDE**

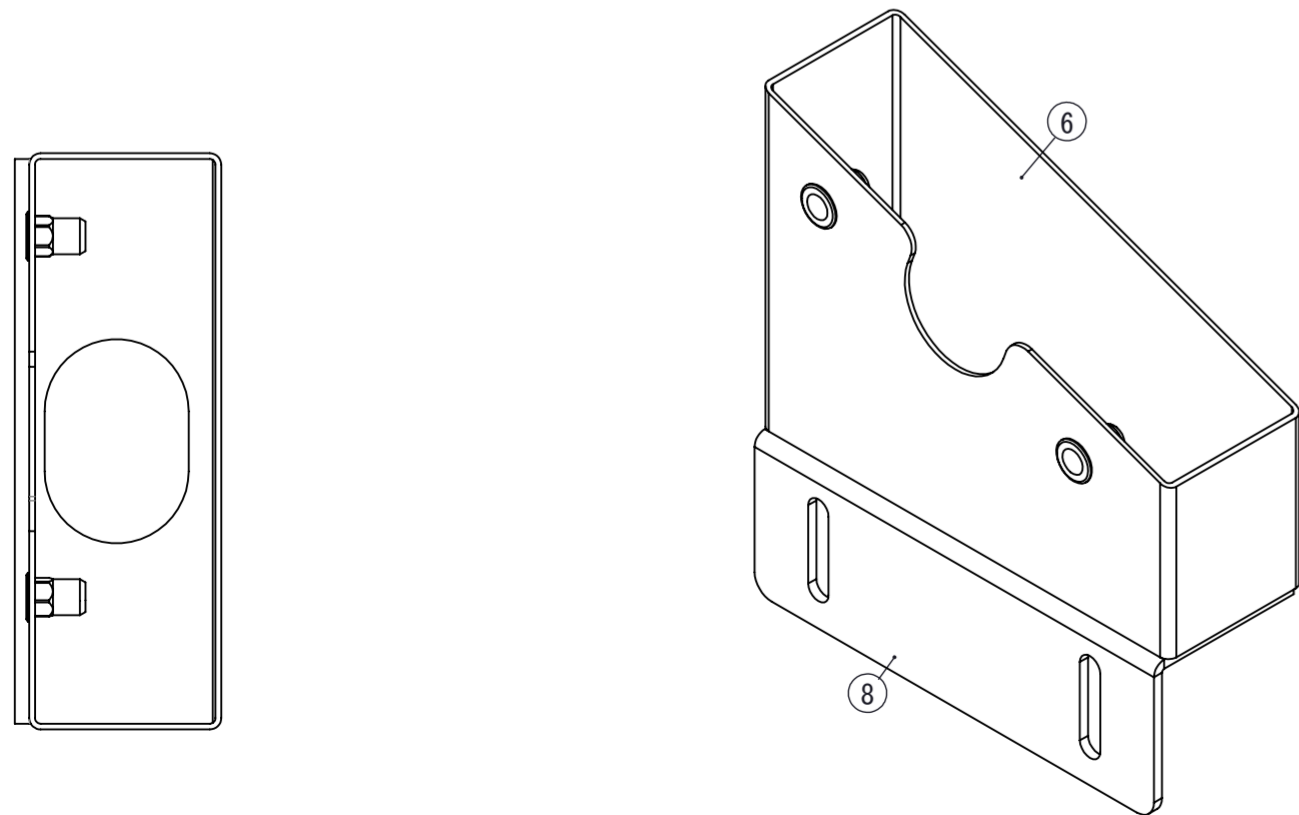
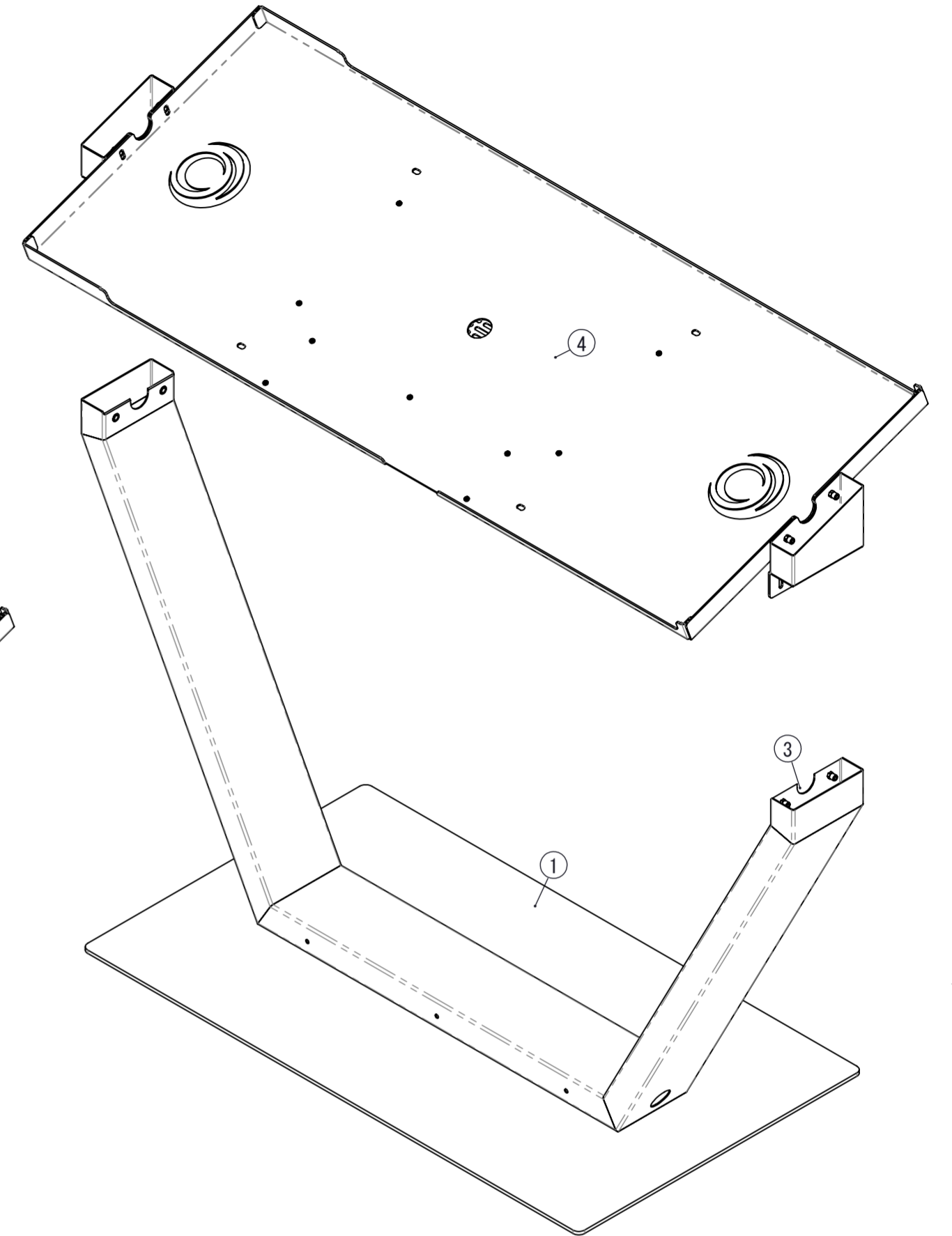
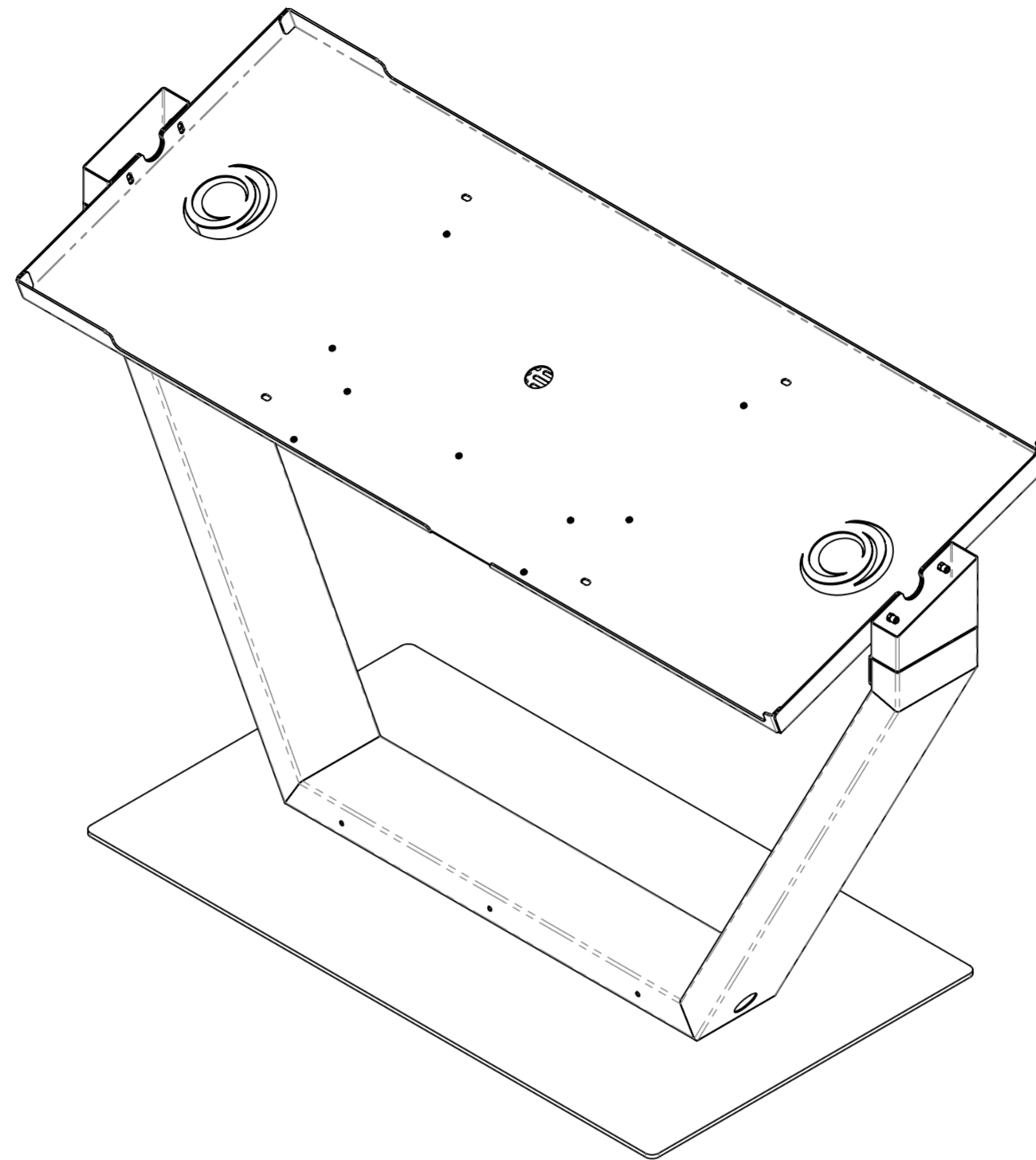

**SLANT ADD-ON  
RIGHT SIDE**

UNLESS OTHERWISE SPECIFIED: DIMENSIONS ARE IN INCHES SURFACE FINISH: TOLERANCES: LINEAR: .01 ANGULAR: .5		FINISH:	DEBUR AND BREAK SHARP EDGES		DO NOT SCALE DRAWING	REVISION
				<b>Digital Touch Systems</b>		
DRAWN:		NAME	SIGNATURE	DATE	TITLE:	
CHK'D:						
APP'V'D:						
MFG:						
Q.A.:						
		MATERIAL:		DWG NO. <b>DTS-65-LKN</b>		A2
		WEIGHT:		SCALE: 1:16		SHEET 3 OF 6

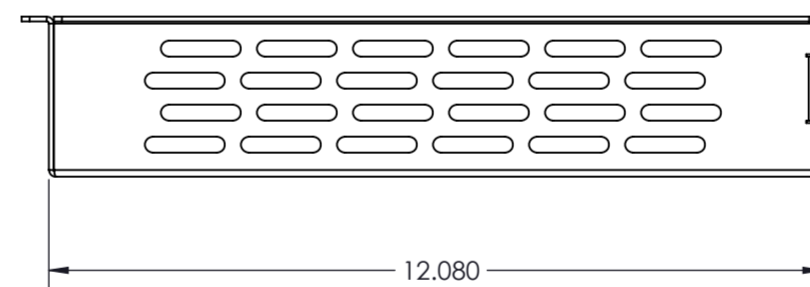
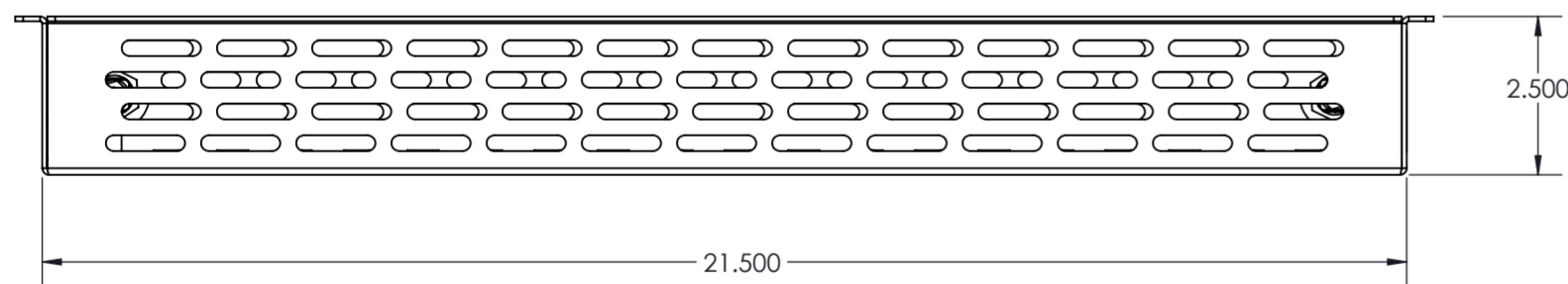
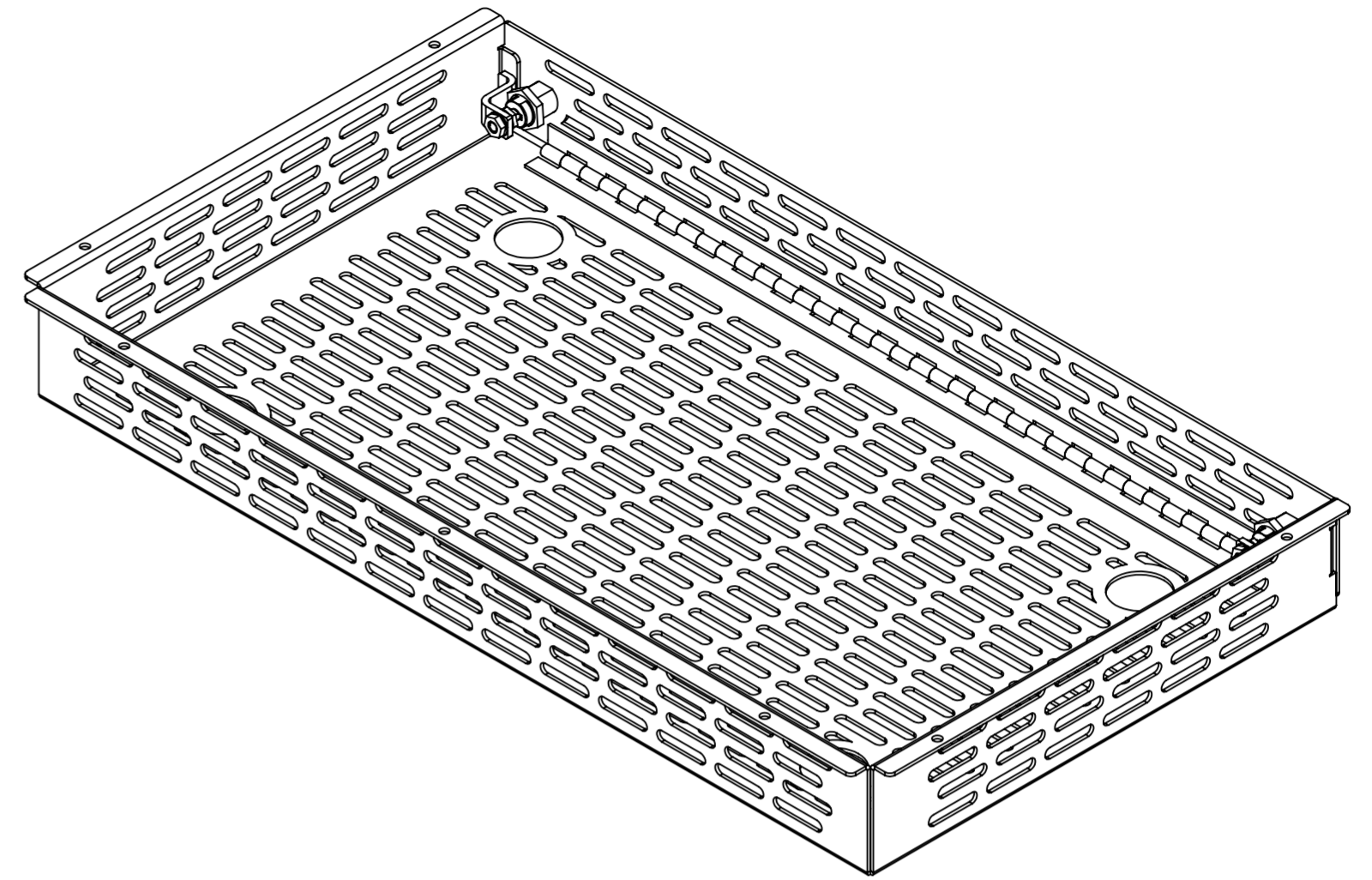
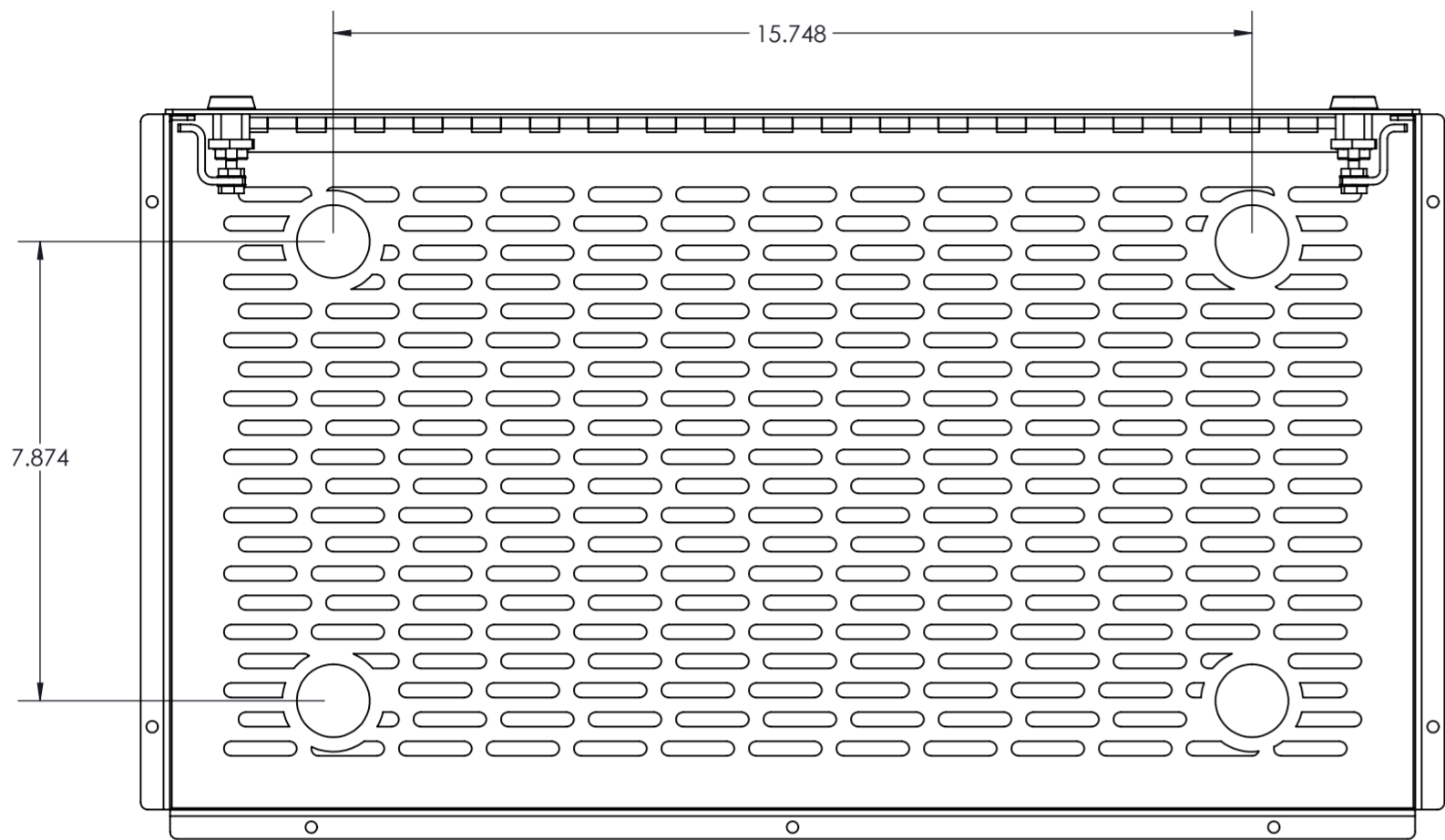

UNLESS OTHERWISE SPECIFIED: DIMENSIONS ARE IN INCHES SURFACE FINISH: TOLERANCES: LINEAR: .01 ANGULAR: .5				FINISH:		DEBUR AND BREAK SHARP EDGES		DO NOT SCALE DRAWING		REVISION	
								<b>Digital Touch Systems</b>			
								TITLE:			
DRAWN:		NAME		SIGNATURE		DATE					
CHK'D:											
APP'VD:											
MFG:											
Q.A:								MATERIAL:		DWG NO. <b>DTS-65-LKN</b>	
								WEIGHT:		SCALE: 1:8	
										SHEET 4 OF 6	

ITEM NO.	PART NUMBER	DESCRIPTION	QTY.
1	DTS-65-LKN-BASE	.25" CRS	1
2	DTS-65-LKN-COVER	.06 CRS	1
3	DTS-65-LKN-LEGS-CRS	2X6X0.075" CRS RECT TUBING	1
4	DTS-65-LKN-PAN	12GA CRS	1
5	DTS-65-LKN-SLANT-1-CRS	11GA CRS	1
6	DTS-65-LKN-SLANT-3-CRS	2X6X0.075" CRS RECT TUBING	1
7	DTS-65-LKN-SLANT-2-CRS	2X6X0.075" CRS RECT TUBING	1
8	DTS-65-LKN-SLANT-4-CRS	11GA CRS	1
9	20160627-141142-03547594	10-32 SS PEM NUT	9
10	AEHS8-420-165	1/4-20 HEX RIVNUT	8
11	DTS-SLT-1	.075 CRS	1
12	DTS-SLT-2	.075 CRS	1
13	SS61015-01	1" SS HINGE	2
14	3-13BK01	STANDARD DIGITAL TOUCH LOCK	2
15	NEP650-003	CUSTOMER REFERENCED PART	1

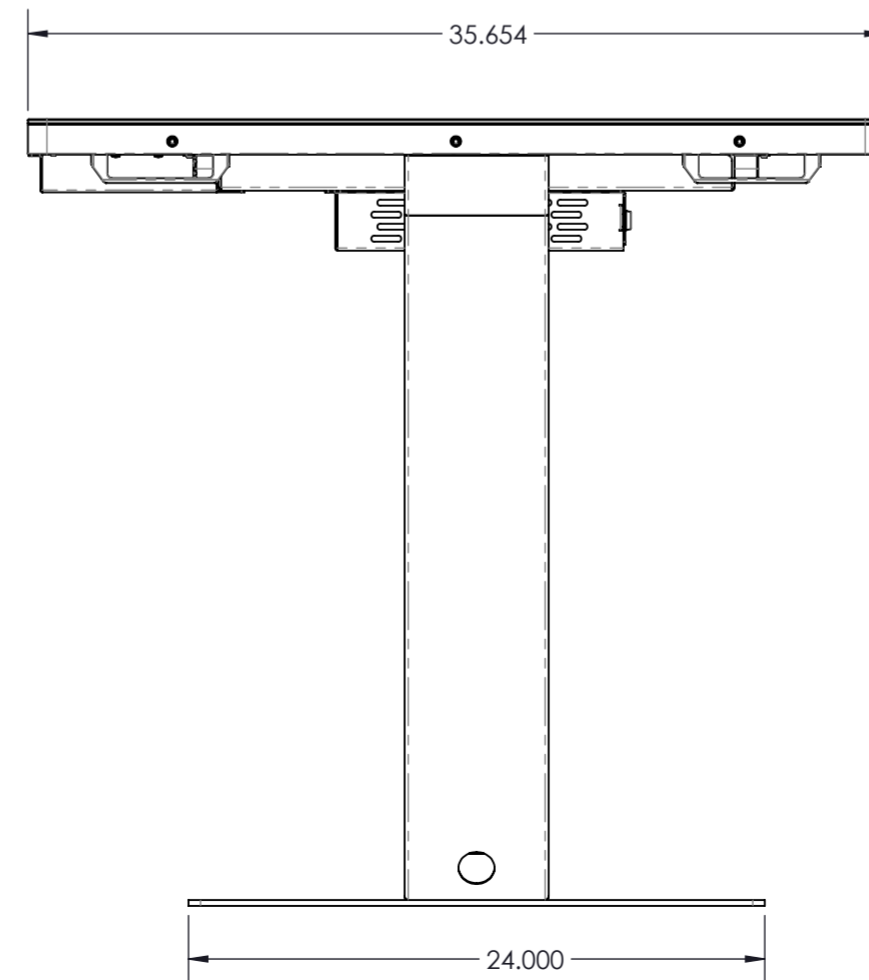
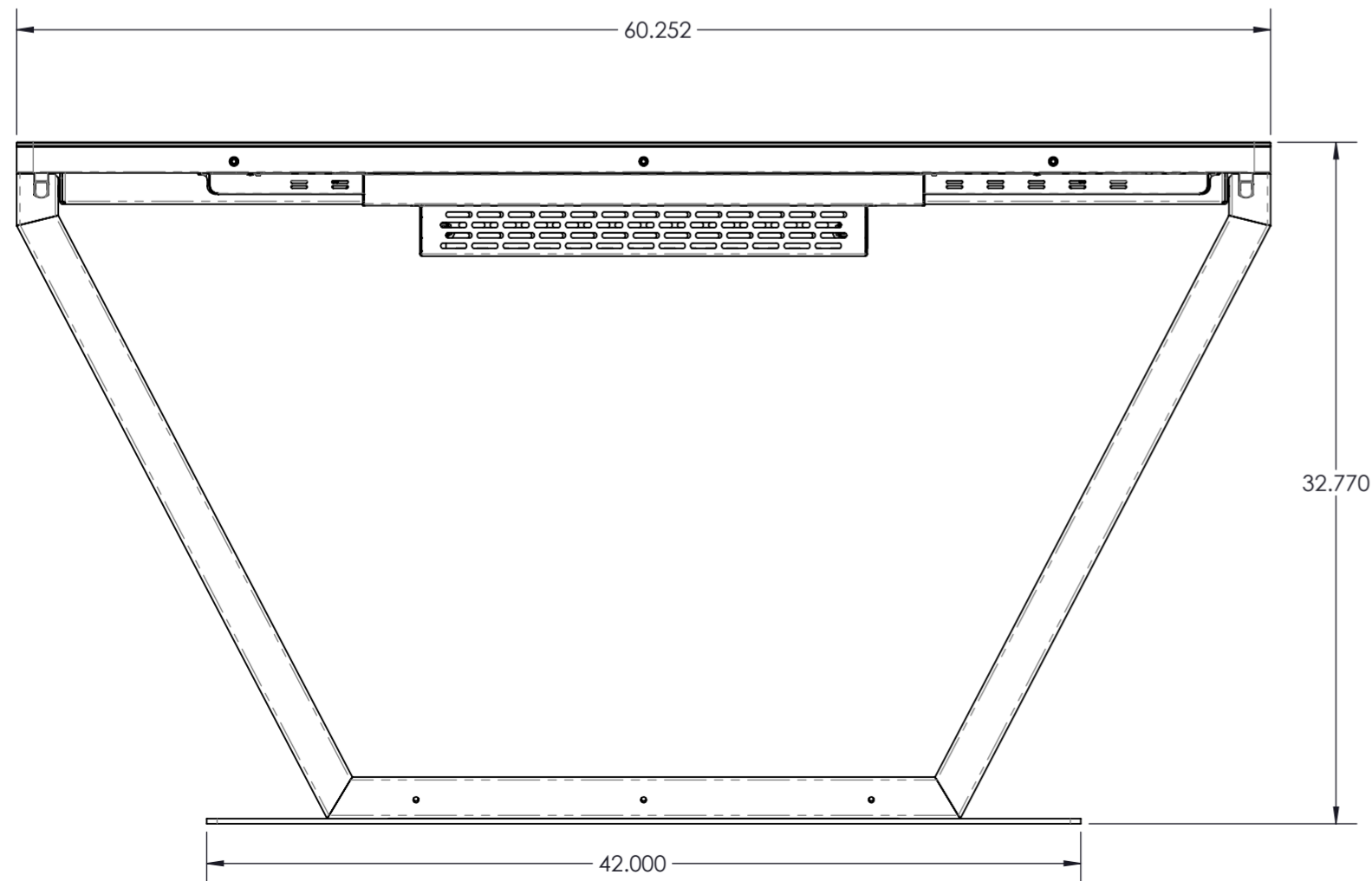
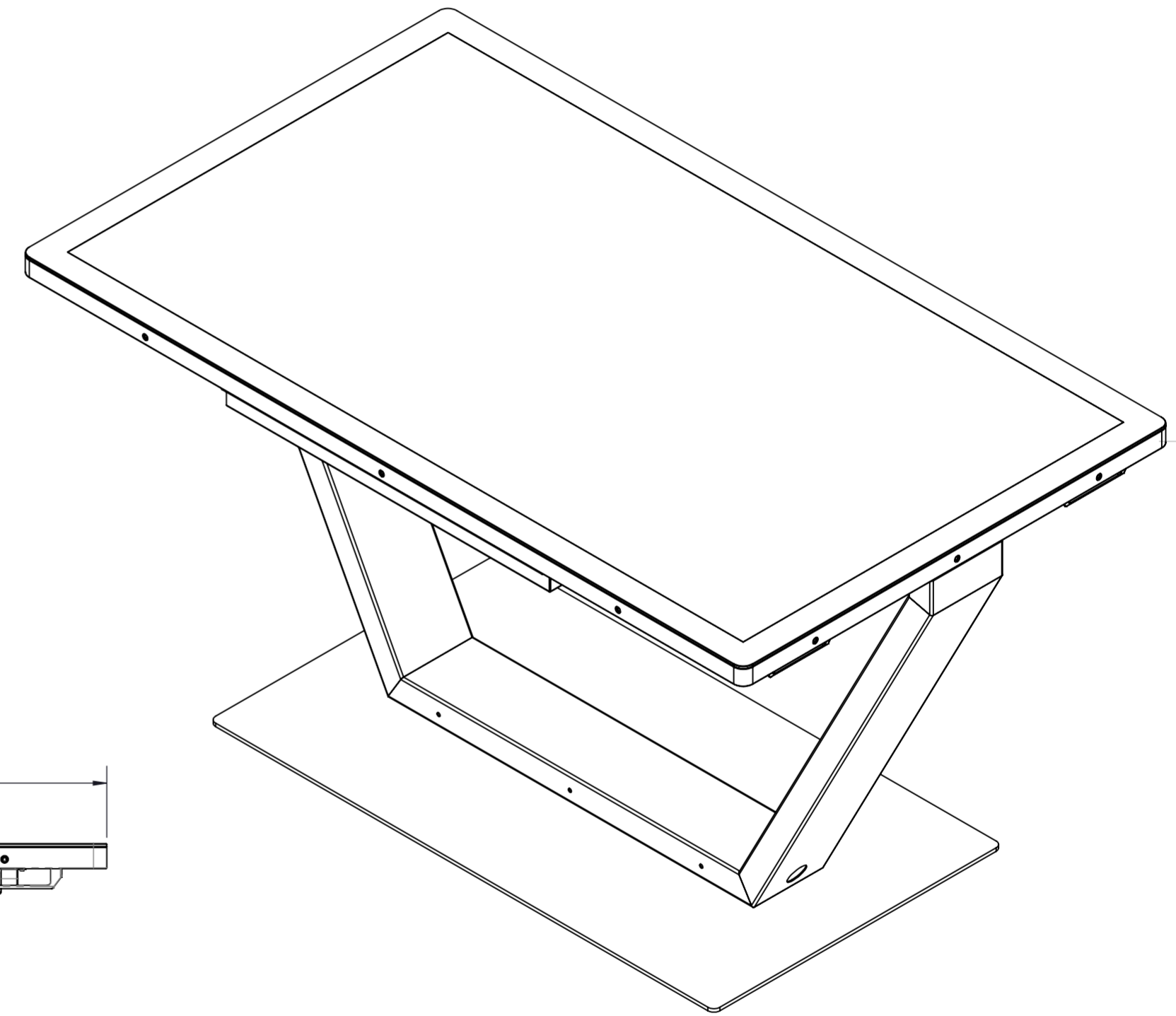
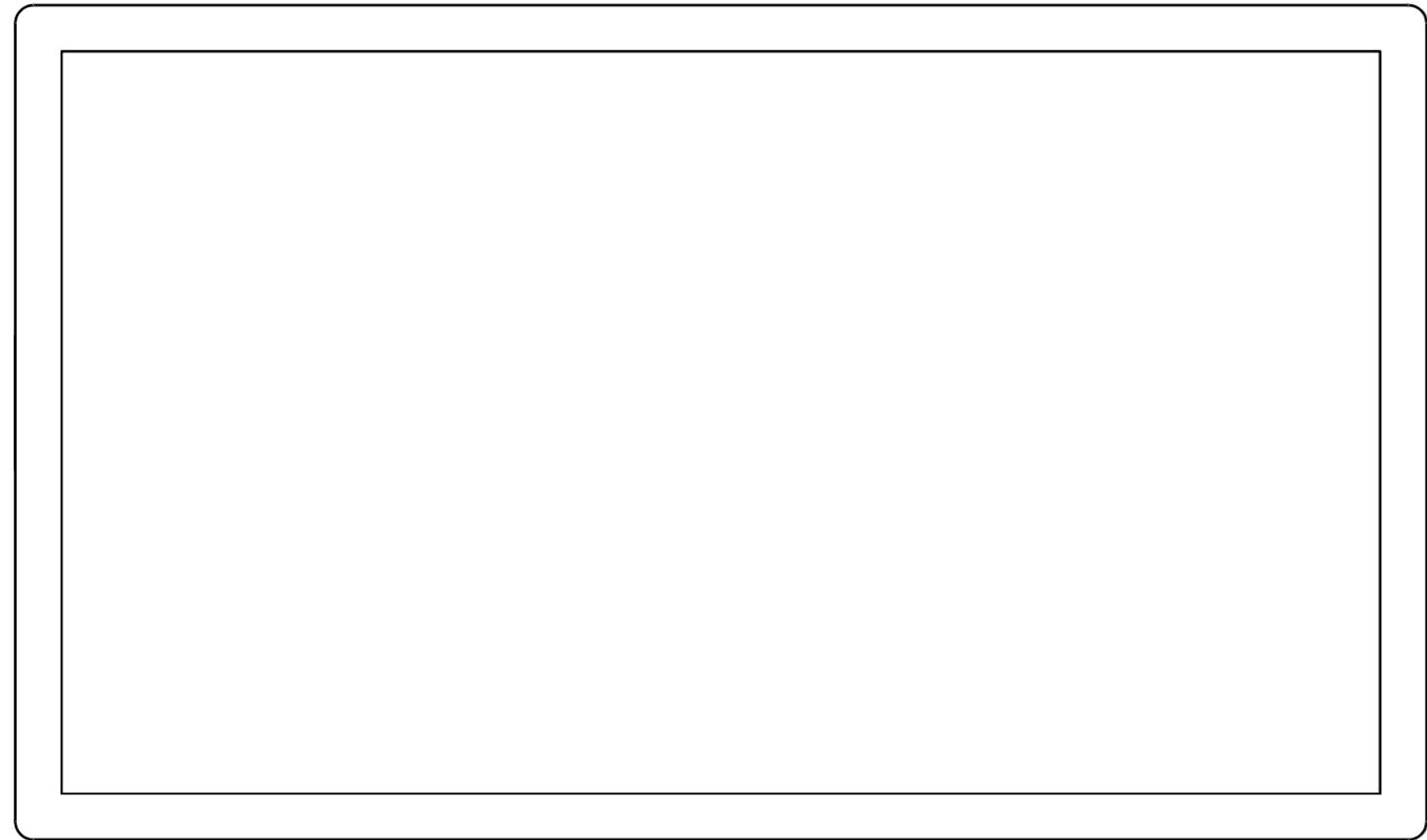

UNLESS OTHERWISE SPECIFIED: DIMENSIONS ARE IN INCHES SURFACE FINISH: TOLERANCES: LINEAR: .01 ANGULAR: .5		FINISH:	DEBUR AND BREAK SHARP EDGES	DO NOT SCALE DRAWING	REVISION
				<b>Digital Touch Systems</b>	
DRAWN:	NAME	SIGNATURE	DATE	TITLE:	
CHK'D:					
APP'V'D:					
MFG:					
Q.A.				MATERIAL:	DWG NO. <b>DTS-65-LKN</b>
				WEIGHT:	A2
				SCALE: 1:16	SHEET 5 OF 6

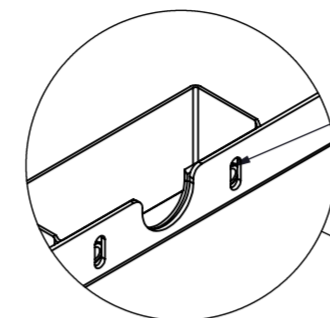

1/4-20 HEX RIVNUT  
IN TUBING TO BOLT  
PAN INTO. NO NEED  
TO REACH INSIDE  
TUBING.

DETAIL D  
SCALE 1 : 4

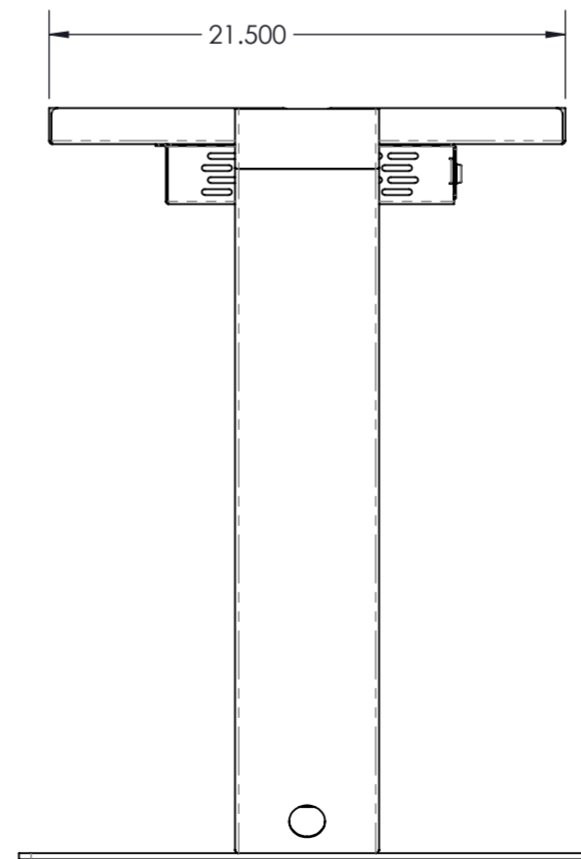
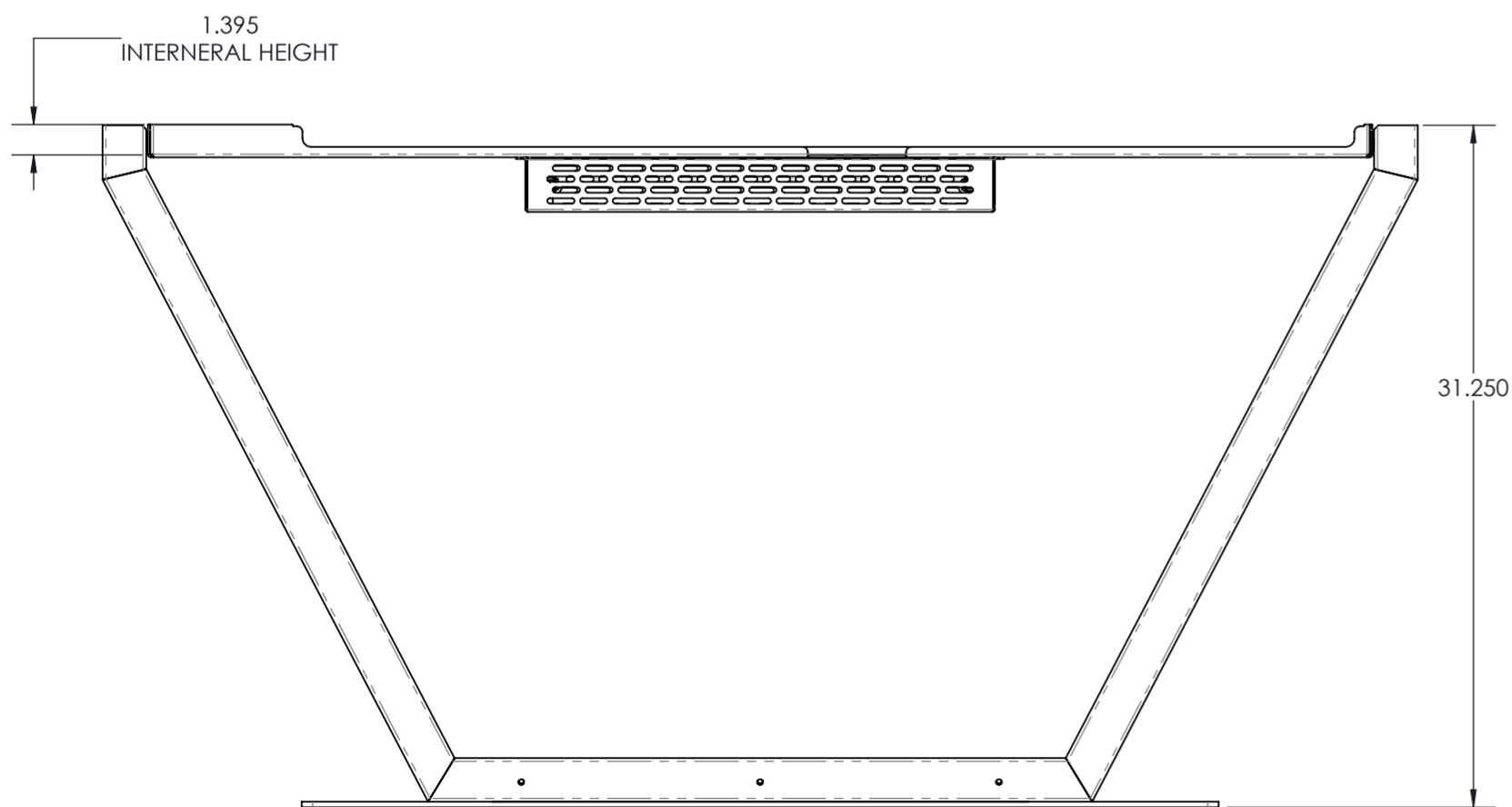
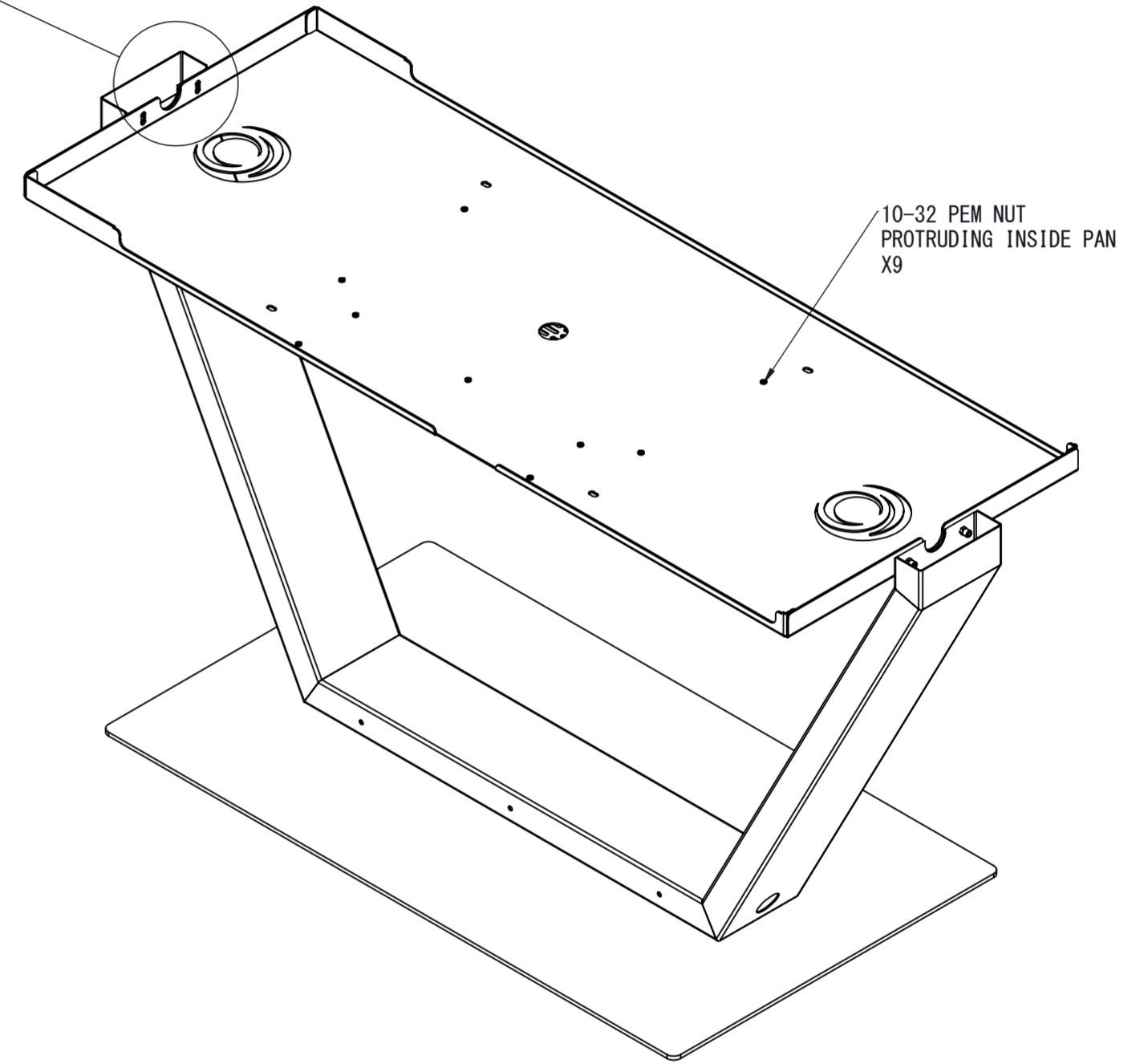
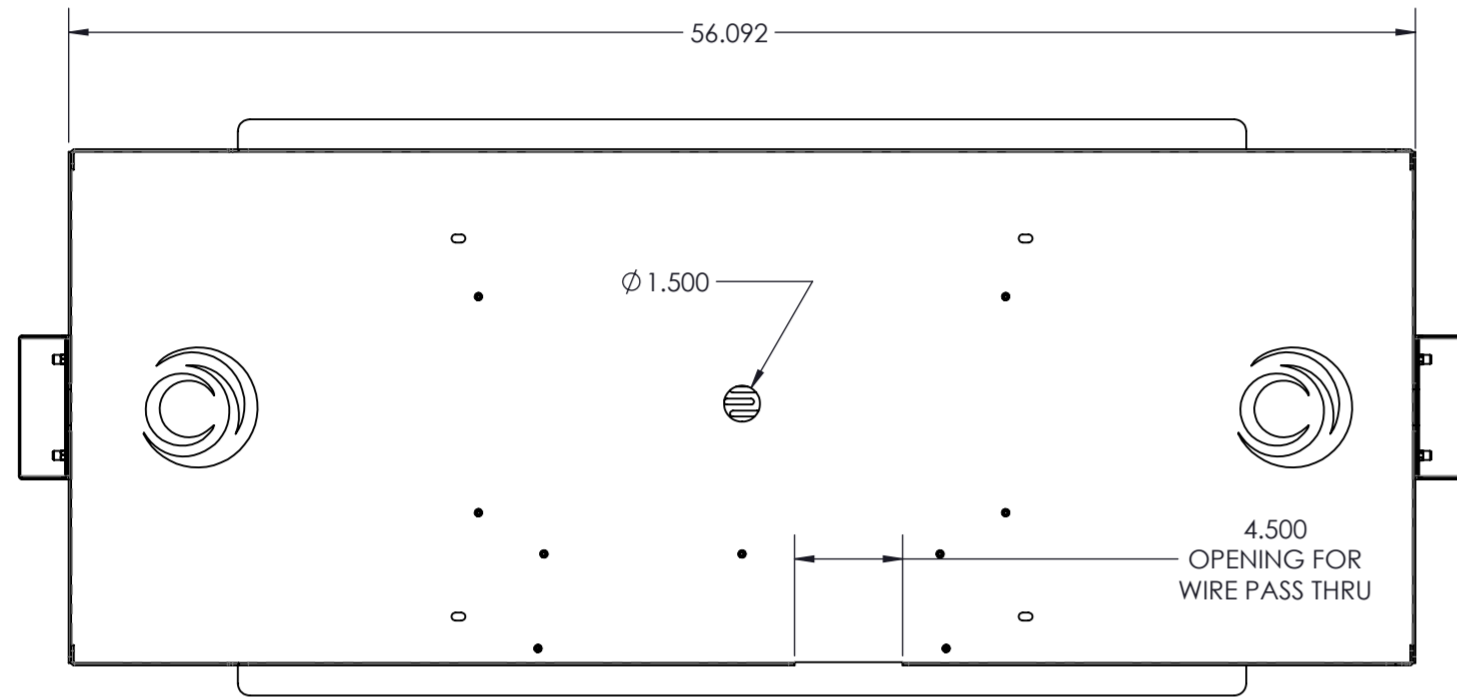

UNLESS OTHERWISE SPECIFIED: DIMENSIONS ARE IN INCHES SURFACE FINISH: TOLERANCES: LINEAR: .01 ANGULAR: .5		FINISH:	DEBUR AND BREAK SHARP EDGES	DO NOT SCALE DRAWING	REVISION
				<b>Digital Touch Systems</b>	
				TITLE:	
DRAWN:	NAME	SIGNATURE	DATE		
CHK'D:					
APP'V'D:					
MFG:					
Q.A.				MATERIAL:	DWG NO. <b>DTS-65-LKN</b>
				WEIGHT:	A2
				SCALE: 1:16	SHEET 6 OF 6