

Model ED 720 | Drying and heating chambers with gravity convection

The strengths of a BINDER ED series drying chamber include routine drying and sterilization tasks up to 300 °C. Thanks to the natural convection, all thermal processes which use this drying chamber are highly efficient. The ED series ensures fast, uniform drying.

BENEFITS

- Best energy efficiency on the market
- Excellent temporal and spatial temperature accuracy
- USB connection for recording data
- Temperature range up to +300 °C

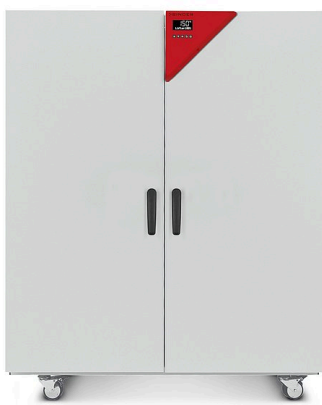

Model 720

MAIN FEATURES

- Temperature range: ambient temperature plus 5 °C to 300 °C
- High temperature accuracy thanks to APT.line™ technology
- Gravity convection
- Controller with LCD display
- Electromechanical control of the exhaust air flap
- 2 chrome-plated racks
- Class 2 independent temperature safety device (DIN 12880) with visual temperature alarm
- Ergonomic handle design
- USB port for recording data

ORDERING INFORMATION

Interior volume [cu.ft.]	Voltage	Option model	Version	Art.-No.
26.2	400 V 3~ 50/60 Hz	Standard	ED720-400V-I	9010-0341

TECHNICAL DATA

Description	ED720-400V-I ¹
Article Number	9010-0341
Performance Data Temperature	
Temperature range +5 °C above ambient temperature to	300 °C
Temperature variation at 150 °C [± K]	3.2
Temperature fluctuation at 150 °C [± K]	0.8
Heating-up time to 150 °C [min]	85
Recovery time after 30 seconds door open at 150 °C [min]	25
Electrical data	
Rated Voltage [V]	400
Power frequency [Hz]	50/60
Nominal power [kW]	4.1
Unit fuse [A]	16
Phase (Nominal voltage)	3~
Measures	
Interior volume [cu.ft.]	26.2
Net weight of the unit (empty) [lbs]	355
Permitted load [lbs]	694
Load per rack [lbs]	99
Wall clearance back [in]	6.3
Wall clearance sidewise [in]	3.94
Internal Dimensions	
Width [in]	37.82
Height [in]	50.4
Depth [in]	23.84
Doors	
Inner doors	2
Unit doors	2
Housing dimensions not incl. fittings and connections	
Width net [in]	45.9
Height net [in]	62.6
Depth net [in]	34.28
Environment-specific data	
Energy consumption at 150 °C [Wh/h]	700
Fixtures	
Number of shelves (std./max.)	2/16

¹ All technical data is specified for unloaded units with standard equipment at an ambient temperature of +22 °C ±3 °C and a power supply voltage fluctuation of ±10%. The temperature data is determined in accordance to BINDER factory standard following DIN 12880, observing the recommended wall clearances of 10 % of the height, width, and depth of the inner chamber. All indications are average values, typical for units produced in series. We reserve the right to change technical specifications at any time.

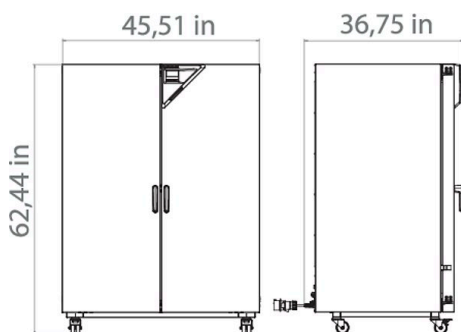
DIMENSIONS INCL. FITTINGS AND CONNECTIONS [MM]**OPTIONS**

Designation	Description	*	Art.-No.
	back		
	10 mm	01	8012-1282
	30 mm	01	8012-0540
	50 mm	01	8012-0546
	left		
	10 mm	01	8012-1275
	30 mm	01	8012-1018
	50 mm	01	8012-1022
	100 mm	01	8012-1030
Access port with silicone plug	right		
	10 mm	01	8012-1268
	30 mm	01	8012-1017
	50 mm	01	8012-1021
	100 mm	01	8012-1031
	top		
	10 mm	01	8012-1262
	30 mm	01	8012-0539
	50 mm	01	8012-0545
	100 mm	01	8012-1029
Alarm function for overheating	Switchable acoustic alarm, with adjustable limit value on the independent temperature safety device	-	8012-1635
Analog output 4-20 mA	for temperature values (output not adjustable)	02	8012-1623
Calibration certificate, expanded	for temperature; for extending the measurement in center of chamber to include another test temperature	-	8012-1115
	for temperature, measurement in center of chamber at specified temperature	-	8012-1134
Calibration certificate, temperature	temperature measurement incl. certificate and 27 measuring points at specified temperature	-	8012-1593
	temperature measurement incl. certificate, 15- 18 measuring points at specified temperature	-	8012-1572
	temperature measurement incl. certificate, 9 measuring points at specified temperature	-	8012-1551
Class 3.1 independent temperature safety device	with visual alarm (DIN 12880)	-	8012-0985
Clock	battery-backed	-	8012-1640
Door gasket	made of FKM, silicone-free	-	8012-1013
Door lock	lockable door handle	-	8012-1817
Ethernet interface	for Multi Management Software APT-COM™	-	8012-1836
Inner chamber, reinforced	max. total load 350 kg	-	8012-1827
Interior lighting	with two 15 W light bulbs 400 V option model	-	8012-1824

* Notes > See last page

Designation	Description	*	Art.-No.
Measurement of air exchange rate	in accordance with ASTM D5374, definition and protocol according to ambient temperature	-	8012-0195
Pt 100 temperature sensor	additional flexible Pt 100, interior, for displaying the temperature on the unit display	-	8012-1619
Viewing window and interior lighting	viewing window (triple insulating glass) in door, 300 x 480 mm, and 30 W interior 400 V option model	-	8012-1830

* Notes › See last page

ACCESSORIES

Designation	Description	*	Art.-No.
Data Logger Kit	T 350: For continuous temperature logging from 0 °C to 350 °C; kit includes 1 data logger, Pt 100 sensor with 2 m extension cable and 1 magnetic fixture for mounting to the BINDER unit	-	8012-0714
Data Logger Software	LOG ANALYZE software kit, configuration and evaluation software for all BINDER Data Logger Kits (incl. USB data cable)	-	8012-0821
Multi Management Software	Multi Management Software APT-COM™		
	version 4, BASIC edition	-	9053-0039
	version 4, GLP edition	-	9053-0042
	version 4, PROFESSIONAL edition	-	9053-0040
pH-neutral detergent	concentrated, for gentle remove of residual contaminants; 1 kg	-	1002-0016
Qualification documents	IQ/OQ documents – supporting documents for validation performed by customers, consisting of: IQ/OQ checklists incl. calibration guide and comprehensive unit documentation; parameters: temperature, CO ₂ , O ₂ , pressure, depending on unit		
	Digital in PDF format	-	7057-0001
	Hard copy inside folder	-	7007-0001
	IQ/OQ/PQ documents – supporting documents for validation performed by customers, according to customer requirements, PQ section added to qualification folder IQ/OQ; parameters: temperature, CO ₂ , O ₂ – or pressure, depending on unit		
	Digital in PDF format	-	7057-0005
	Hard copy inside folder	-	7007-0005
Rack	chrome plated	-	6004-0179
	stainless steel	-	6004-0163
Rack, heavy load	Stainless steel, max. load per rack 70 kg	-	6004-0246
Shelf, perforated	Stainless steel	-	6004-0195

* Notes › See last page

SERVICES

Designation	Description	*	Art.-No.
Installation services			
Unit installation	Connect the unit to the customer-side connections (electricity, water, wastewater, gas), basic functions check, brief operating instructions. (excl.: unpacking, setup, controller instructions, programming, installation work)	05	DL10-0100
Unit instructions	Instruction regarding operating principle and basic functions of the unit, operation of the control electronics including programming	05	DL10-0500
Maintenance services			
BRONZE 3-year maintenance contract	Maintenance service as contractually agreed, visual inspection of mechanical and electrical components, check of control response, 20% discount on spare parts	05	DL20-0710
GOLD 3-year maintenance contract	Maintenance service as contractually agreed, visual inspection of mechanical and electrical components, check of control response, 20% discount on spare parts, testing of all key functions, replacement of wear parts, calibration of one test temperature specified by the user in the center of the usable space, including certificate	05	DL20-0910
Maintenance	One-off maintenance service in accordance with maintenance schedule. Visual inspection of mechanical and electrical components, testing of all key functions. Calibration of a test temperature specified by the user in center of usable space without certificate	05	DL20-0200
SILVER 3-year maintenance contract	Maintenance service as contractually agreed, visual inspection of mechanical and electrical components, check of control response, 20% discount on spare parts, testing of all key functions, calibration of one test temperature specified by the user in the center of the usable space, without certificate	05	DL20-0810

* Notes › See last page

Designation	Description	*	Art.-No.
Calibration services			
Measurement of air exchange rate	including certificate (in accordance with ASTM D5374)	03, 04, 05	DL33-0000
Temperature calibration	Calibration of one (1) test temperature specified by the user in center of chamber, including certificate	03, 04, 05	DL30-0101
	Extension of calibration of one (1) additional test temperature specified by the user in the center of the usable space, including certificate	03, 04, 05	DL30-0102
Temperature measurement, 18 measuring points	Temperature measurement with 18 measuring points with a set value specified by the user, including certificate	03, 04, 05	DL30-0118
Temperature measurement, 27 measuring points	Temperature measurement with 27 measuring points with a set value specified by the user, including certificate	03, 04, 05	DL30-0127
Temperature measurement, 9 measuring points	Temperature measurement with 9 measuring points with a set value specified by the user, including certificate	03, 04, 05	DL30-0109
Validation services			
Execution of IQ/OQ	Execution of IQ/OQ in accordance with qualification folder	05	DL40-0100
Execution of IQ/OQ/PQ	Execution of IQ/OQ/PQ in accordance with qualification folder	05	DL44-0500
Warranty service			
Warranty extension from 2 to 3 years	The warranty is extended by 1 year from the delivery date, wear parts are excluded	-	DL50-0010

* Notes › See last page

NOTES

- 01 Condensation may occur in the area around the access port. Access ports may be placed in custom locations for an additional charge.
- 02 UL mark is not granted when this option is used.
- 03 Sensor calibration is performed in an accredited calibration laboratory.
- 04 Calibration is performed according to the BINDER factory standard.
- 05 Quoted prices do not include travel costs. Please refer to the chapter on BINDER Service for travel costs for your region. Quoted prices for services performed in Switzerland do not include a country-specific added fee (available on request).

BINDER GmbH

Tuttlingen, Germany
TEL +49 7462 2005 0
FAX +49 7462 2005 100
info@binder-world.com
www.binder-world.com

BINDER Asia Pacific (Hong Kong) Ltd.

Kowloon, Hong Kong, P.R. China
TEL +852 39070500
FAX +852 39070507
asia@binder-world.com
www.binder-world.com

Representative Office for CIS

Moscow, Russia
TEL +7 495 988 15 16
FAX +7 495 988 15 17
russia@binder-world.com
www.binder-world.com

**BINDER Environmental Testing
Equipment (Shanghai) Co., Ltd.**

Shanghai, P.R. China
TEL +86 21 685 808 25
FAX +86 21 685 808 29
china@binder-world.com
www.binder-world.com

BINDER Inc.

Bohemia, NY, USA
TEL +1 631 224 4340
FAX +1 631 224 4354
usa@binder-world.com
www.binder-world.us