

E-TC

Ethernet-based 8-Channel Thermocouple Input Device

User's Guide

Trademark and Copyright Information

Measurement Computing Corporation, InstaCal, Universal Library, and the Measurement Computing logo are either trademarks or registered trademarks of Measurement Computing Corporation. Refer to the Copyrights & Trademarks section on mccdaq.com/legal for more information about Measurement Computing trademarks. Other product and company names mentioned herein are trademarks or trade names of their respective companies.

© 2016 Measurement Computing Corporation. All rights reserved. No part of this publication may be reproduced, stored in a retrieval system, or transmitted, in any form by any means, electronic, mechanical, by photocopying, recording, or otherwise without the prior written permission of Measurement Computing Corporation.

Notice

Measurement Computing Corporation does not authorize any Measurement Computing Corporation product for use in life support systems and/or devices without prior written consent from Measurement Computing Corporation. Life support devices/systems are devices or systems that, a) are intended for surgical implantation into the body, or b) support or sustain life and whose failure to perform can be reasonably expected to result in injury. Measurement Computing Corporation products are not designed with the components required, and are not subject to the testing required to ensure a level of reliability suitable for the treatment and diagnosis of people.

Table of Contents

Preface

About this User's Guide	5
What you will learn from this user's guide	5
Conventions in this user's guide	5
Where to find more information	5

Chapter 1

Introducing the E-TC.....	6
Ethernet interface.....	6
Functional block diagram	6

Chapter 2

Installing the E-TC.....	7
Unpacking.....	7
Installing the software	7
Connecting the external power adapter	7
Installing the hardware	7
Configuring network settings	7
Address mode settings	7
IP address settings.....	8
Connection code	8
Configuring the network router for communication across networks	8
Calibrating the hardware.....	9
Factory calibration	9
Field calibration	9
Updating firmware.....	9
Restoring factory default network settings	9

Chapter 3

Functional Details	10
External components	10
Screw terminals.....	10
LED status indicators.....	11
RESET button	11
Ethernet connector	11
External power connector	11
Signal connections.....	11
TC input.....	11
Digital I/O.....	12
Counter input	15
Power output.....	15
Ground.....	15
Mechanical drawings.....	16
DIN-rail compatible	18

Chapter 4

Specifications	19
Thermocouple input.....	19
Channel configurations.....	20
Compatible thermocouples	20
Accuracy.....	20
Thermocouple measurement accuracy	20
Digital input/output.....	21

Temperature alarms	22
Counter	22
Memory	22
Power	23
Network	23
Ethernet connection	23
Network interface	23
Network factory default settings	23
Network security	24
LED displays and the factory reset button	24
Environment	24
Mechanical	24
Screw terminal connector	25
Declaration of Conformity	26

About this User's Guide

What you will learn from this user's guide

This user's guide describes the Measurement Computing E-TC data acquisition device and lists device specifications.

Conventions in this user's guide

For more information

Text presented in a box signifies additional information related to the subject matter.

Caution! Shaded caution statements present information to help you avoid injuring yourself and others, damaging your hardware, or losing your data.

bold text **Bold** text is used for the names of objects on a screen, such as buttons, text boxes, and check boxes.

italic text *Italic* text is used for the names of manuals and help topic titles, and to emphasize a word or phrase.

Where to find more information

Additional information about E-TC hardware is available on our website at www.mccdaq.com. You can also contact Measurement Computing Corporation with specific questions.

- Knowledgebase: kb.mccdaq.com
- Tech support form: www.mccdaq.com/support/support_form.aspx
- Email: techsupport@mccdaq.com
- Phone: 508-946-5100 and follow the instructions for reaching Tech Support

For international customers, contact your local distributor. Refer to the International Distributors section on our website at www.mccdaq.com/International.

Introducing the E-TC

The E-TC is an Ethernet-based thermocouple (TC) data acquisition device that provides the following features:

- Eight 24-bit differential TC inputs
- TC channels field-to-host isolation
- 4 S/s per channel update rate
- Support for type J, K, R, S, T, N, E, and B thermocouples, software-selectable per channel
- Two integrated cold junction compensation (CJC) sensors (one per four TC inputs)
- Open thermocouple detection (OTD) to detect faulty TC connections
- Eight individually-configurable digital I/O channels, isolated from TC channels
- ± 24 mA drive capability
- 10/100 Ethernet interface
- Powered by the included +5 V external power adapter (PS-5V1AEPS)

Ethernet interface

The E-TC has a built-in 10/100 BASE-T auto-negotiation, high-speed communication port. You can remotely access and configure your E-TC from anywhere on the network. Only one computer can control the E-TC at one time. The networking protocols are TCP and UDP.

A unique *media access control* (MAC) address is assigned to each device at the factory. You configure the Ethernet connection settings through software. The network name uses the format E-TC-xxxxxxx, where xxxxxx are the lower six digits of the factory-assigned MAC address.

Functional block diagram

Device functions are illustrated in the block diagram shown here:

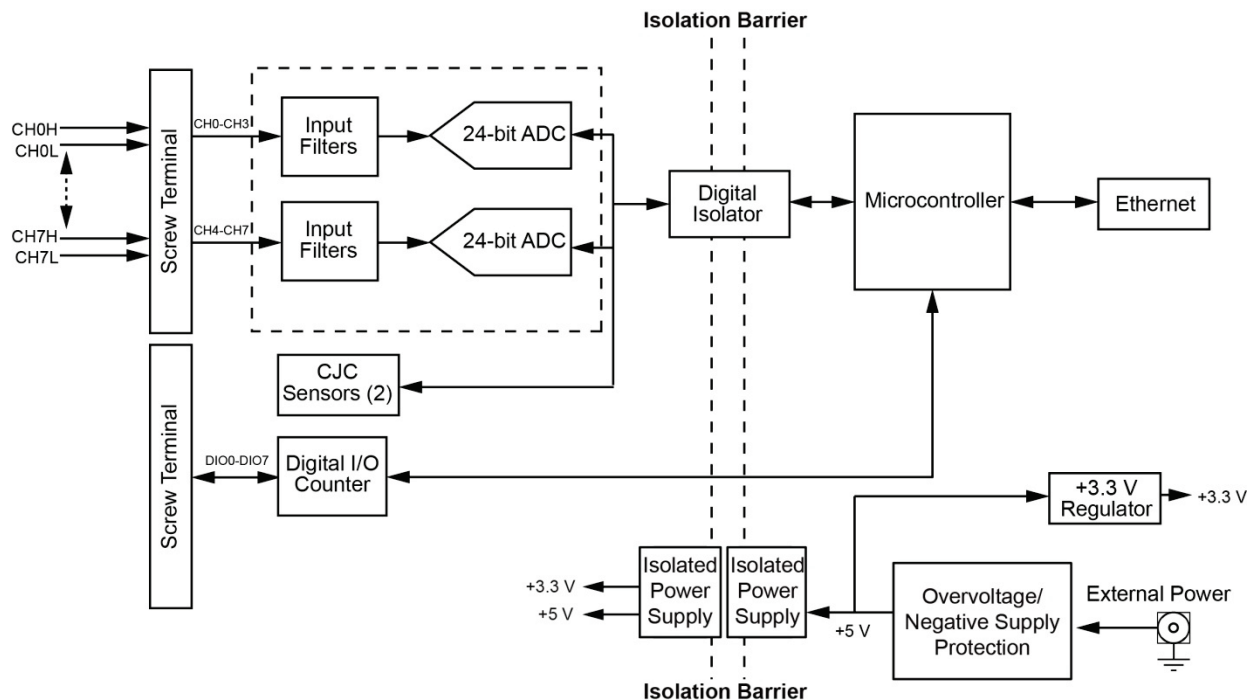

Figure 1. E-TC functional block diagram

Installing the E-TC

Unpacking

As with any electronic device, you should take care while handling to avoid damage from static electricity. Before removing the board from its packaging, ground yourself using a wrist strap or by simply touching the computer chassis or other grounded object to eliminate any stored static charge.

Installing the software

Refer to the MCC DAQ Quick Start and the E-TC product page on our website for information about the available software.

Install the software before you install your device

The driver needed to run the E-TC is installed with the software. Therefore, you need to install the software package you plan to use before you install the hardware.

Connecting the external power adapter

Power to the E-TC is provided with the 5 volt, 1 amp external power adapter (PS-5V1AEPS). Connect the adapter cord to the power connector on the E-TC, and plug the AC adapter into an electrical outlet.

The **Power** LED turns on when 5 V power is supplied to the E-TC. If the voltage supply is less than 4.2 V or more than 5.6 V, the **POWER** LED does not turn on.

Refer to [Figure 2](#) on page 11 for the location of the **Power** LED.

Installing the hardware

The E-TC requires a TCP/IP and UDP connection to a network or computer. Use the standard Ethernet cable provided to connect the E-TC to a 10Base-T or 100Base-TX compatible Ethernet port, hub, or switch.

When connecting the E-TC for the first time, make sure that you connect to a local network with DHCP enabled.

If you are unsure whether you have access to a local network or that DHCP is enabled on that network, you should use a direct connection to a Windows PC.

It may take a minute or two to detect the device and assign the address. The green **Link/activity** LED on the lower left of the Ethernet connector turns on when there is a valid Ethernet link, and blinks when network activity is detected.

Once the E-TC is physically connected to the local network or PC, you can run the software (InstaCal for example) to establish a connection. If a connection cannot be established, make sure the device is using the default configuration by following the instructions in the [Restoring factory default network settings](#) on page 9.

Once a connection is established and you can communicate to the device, you can change the configuration for other network scenarios.

Configuring network settings

The following E-TC network settings are software-selectable. Only one user at a time can connect to the E-TC to configure network options on the device. For typical local networks, the default settings are recommended.

Address mode settings

The address mode setting determines whether the default IP parameters (IPv4 address, subnet mask, and gateway) are assigned to the E-TC or an auto-addressing method is used to assign these parameters.

DHCP or link-local enabled (default)

If connected to a network with a DHCP server, the service automatically assigns IP addresses to the E-TC.

If the connected network does not have a DHCP server, the address stored in the default IP address is assigned to the E-TC.

If the E-TC is directly connected to a Windows PC or other host that supports link-local addressing, a link-local address is assigned to the device. A link-local address is valid only for communications between the E-TC and the device to which it is connected

DHCP Only

Enables configuration by a DHCP server, if one is available. The E-TC is assigned an IP address shortly after it is powered up and attached to the network.

Link Local Only

The E-TC is assigned a link-local IP address by the Windows PC or other host that supports link-local addressing. A link-local address is valid only for communications between the E-TC and the device to which it is connected.

Static

The default **IPv4 Address** is manually configured on the E-TC.

IP address settings

The default settings of the following IP address are assigned to the E-TC when automatic addressing is disabled or not available (DHCP or Link Local for example)

- **IPv4 address** – The IP address that is stored on the device. The default IPv4 address is 192.168.0.101.
- **Subnet mask** – The Subnet mask that is stored on the E-TC . The subnet mask determines the number of bits of the IP address that is used for the host portion of the address vs. the number of bits used for the network portion. The default subnet mask is 255.255.255.000
- **Gateway** – The gateway IP address that is stored on the E-TC. The gateway address of the device that bridges subnets within a network. The default gateway is 192.168.0.1

Connection code

The connection code is a number between 0 (default) and 999999999. You can change this number from its default of 0 to prevent other users from connecting to and configuring the device. The device remains visible to other users on the network, but connection by another user is not allowed.

Configuring the network router for communication across networks

In order to communicate with the E-TC from a computer connected to a different network – such as over the Internet – you must change the network configuration of the network router.

In the following procedure, the E-TC is installed on the *host* LAN, the computer is installed on the *client* LAN, and it is assumed that you have successfully connected the device to a local network.

Caution! This procedure should only be performed by a network administrator or computer professional. Incorrect settings can significantly disrupt a network.

1. Determine the IP address of the device. If the address was assigned by DHCP, it is recommended you change it to a static address by setting the default address to the address assigned and setting the device network configuration to static.
2. Configure the firewall/router to forward incoming traffic to the following ports to the IP address assigned to the device:
 - UDP:54211 (discovery)
 - TCP:54211 (commands)

3. On the computer connected to the client LAN, manually enter the WAN address of the host router, and specify the ports that were forwarded to connect to the remote E-TC.

Calibrating the hardware

Factory calibration

The Measurement Computing Manufacturing Test department performs the initial factory calibration. Return the device to Measurement Computing Corporation when calibration is required. The recommended calibration interval is one year.

Field calibration

The E-TC also supports field calibration, as an alternative to returning the device for factory calibration. The same recommended one-year calibration interval applies.

The following items are required to perform field calibration on an E-TC:

- a precision voltage source
- a voltmeter

Each ADC (two ADCs per device) is measured at seven points and a linear correction is calculated.

When prompted, enter the voltmeter reading to a precision of six decimal places.

MCC strongly recommends that you warm up the E-TC for at least 20 minutes prior to performing field calibration.

Updating firmware

Your DAQ device contains firmware that can be updated in the field if required. Firmware is available for download at www.mccdaq.com/firmware.aspx. MCC recommends that you check this page periodically to see if an update to your device firmware is available.

Restoring factory default network settings

To reset the network configuration settings to the factory default values, complete the following steps:

1. Use a ballpoint pen to press and hold in the **Reset** button for at least four seconds until both the **Power** and **Activity** LEDs blink twice and then turn off, indicating that network settings have been restored to default values.
2. Release the button so the device continues startup with the default settings.

If the button is released before the two LEDs blink, the settings are not affected and the device starts up normally.

Holding in the Reset button too long may cause the device to enter bootloader mode

Holding the Reset button in after the Power and Activity LEDs blink may cause the device to enter firmware update (bootloader) mode. In this mode both LEDs continuously blink. If this occurs, cycle the power to return the device to normal operation.

If InstaCal is open when default settings are restored, click the **Refresh Boards** button on the InstaCal toolbar to reflect the changes.

Functional Details

External components

The E-TC has the following external components:

- Screw terminals
- LED status indicators
- Ethernet connector
- External power connector
- Factory reset button

Screw terminals

The E-TC screw terminals provide the following connections:

- Eight differential (**CH0H/CH0L** to **CH7H/CH7L**) thermocouple input connections
- Eight digital I/O connections (**DIO0** to **DIO7**)
- One counter input (**CTR**)
- One voltage output (**+VO**)
- Five digital grounds (**GND**) and one chassis ground (**CHGND**)

The location of each signal is shown in Figure 2.

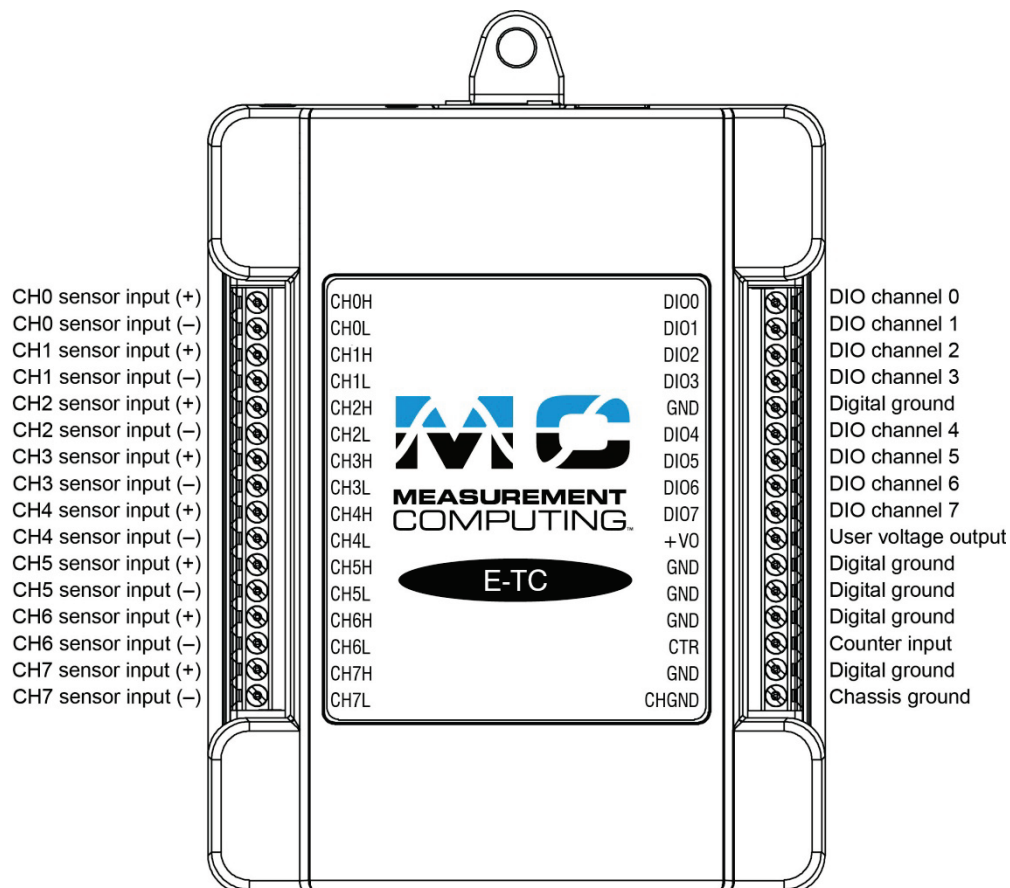
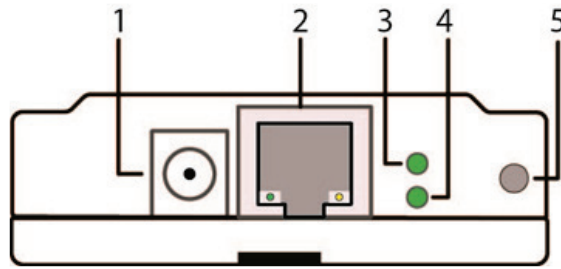

Figure 2. E-TC pinout

The remaining components are on the top edge of the enclosure; refer to Figure 3:



- | | | | |
|---|---|---|-----------------------|
| 1 | External power connector | 4 | Activity LED (bottom) |
| 2 | Ethernet connector with green Link/activity LED (left) and yellow Speed LED (right) | 5 | Factory reset button |
| 3 | Power LED (top) | | |

Figure 3. E-TC connectors, reset button, and status LEDs

LED status indicators

The E-TC has two LED indicators that indicate the status of power and host communications:

- The **Power** LED is on when external power between 4.2 V to 5.6 V is supplied. This LED is off when the external power supply is not connected, or the input power is outside of the 4.2 V to 5.6 V voltage range of the external supply, causing a power fault. The E-TC has an onboard voltage supervisory circuit that monitors the 5 V external power supply.
- The **Activity** LED is on when a valid host connection is detected. This LED blinks when a command is received.

Both Power and Activity LEDs blink once when factory default settings are restored. Refer to [Restoring factory default network settings](#) on page 9 for more information.

RESET button

Press and hold this button to restore the E-TC to its factory default network settings. Both Power and Activity LEDs blink once when factory default settings are restored. Refer to *Restoring factory default network settings* on page 9 for more information.

Ethernet connector

The E-TC has one 10/100 BASE-T, auto-negotiation, high-speed communication port. The port connector is an RJ-45, eight-position connector. The Ethernet port accepts CAT-5 shielded or unshielded twisted pair cable. The maximum communication distance without using a repeater is 100 meters.

External power connector

Connect the PS-5V1AEPS power supply to this connector. The power supply provides 5 VDC, 1 A power to the E-TC.

Signal connections

TC input

A thermocouple consists of two dissimilar metals that are joined together at one end. When the junction of the metals is heated or cooled, a voltage is produced that correlates to temperature.

The E-TC supports type J, K, S, R, B, E, T, N thermocouples.

When TCs are attached to conductive surfaces, the voltage differential between multiple TCs must remain within ± 1.8 V. For best results, MCC recommends using electrically insulated TCs when connected to electrically charged surfaces if possible.

Caution! MCC strongly recommends that you ground yourself using a wrist strap before handling the thermocouple sensors.

Hardware compatibility

The E-TC is functionally equivalent to USB-TC hardware. Software programs written for those devices using the Universal Library can be run with the E-TC.

Cold junction compensation (CJC)

Each group of four TC inputs has a high-resolution CJC sensor. When you connect the thermocouple sensor leads to the sensor input channel, the dissimilar metals at the E-TC terminal blocks produce an additional thermocouple junction. This junction creates a small voltage error component which must be removed from the overall sensor measurement using a CJC technique.

The measured voltage includes both the thermocouple voltage and the cold junction voltage. To compensate for the additional cold junction voltage, the E-TC subtracts the cold junction voltage from the thermocouple voltage.

Increasing the thermocouple length

If you need to increase the length of your thermocouple, use the same type of TC wires to minimize the error introduced by thermal EMFs.

Data linearization

After the CJC correction is performed on the measurement data, an on-board microcontroller automatically linearizes the thermocouple measurement data using National Institute of Standards and Technology (NIST) linearization coefficients for the selected thermocouple type.

The measurement data is then output as a 32-bit floating point value in the configured format (voltage or temperature).

Open-thermocouple detection (OTD)

The E-TC is equipped with OTD for all TC input channels. With OTD, any open-circuit condition at the TC sensor is detected by the software. An open channel is detected by the use of a pull up and pull down resistors on the thermocouple inputs. An open thermocouple condition forces the input differential voltage outside of the valid thermocouple voltage range. The software recognizes this as an invalid reading and flags the appropriate channel. The software continues to sample all channels when OTD is detected.

Input leakage current

With OTD enabled, 65 nA (typical) of input leakage current is injected into the TC. This current can cause an error voltage to develop across the lead resistance of the TC that is indistinguishable from the thermocouple voltage you are measuring. You can estimate this error voltage with the following formula:

$$\text{error voltage} = \text{resistance of the thermocouple} \times 65 \text{ nA}$$

To reduce the error, reduce the length of the TC to lower its resistance, or lower the AWG of the wire by using a wire with a larger diameter. With open-thermocouple detection disabled, 1 nA (typical) of input leakage current is injected into the TC.

Digital I/O

The E-TC has eight digital I/O channels that are electrically isolated from the analog circuits. Each bit is individually configurable for input or output. The digital I/O transfer rate is 5 kHz maximum for software-paced operation on a local network.

When you configure the digital bits for input, you can use the E-TC digital I/O terminals to detect the state of any TTL-level input. Refer to the schematic shown in Figure 4. If you set the switch to the +5V input, DIO0 reads *TRUE* (1). If you move the switch to GND, DIO0 reads *FALSE* (0).

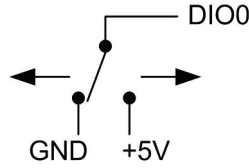

Figure 4. Schematic showing switch detection by digital channel DIO0

Pull-up/down configuration

All DIO channels are pulled high by default to 5 V through 47 kΩ resistors with jumper **W1** on the circuit board (see Figure 5). Each jumper configures a digital port for pull-up or pull-down.

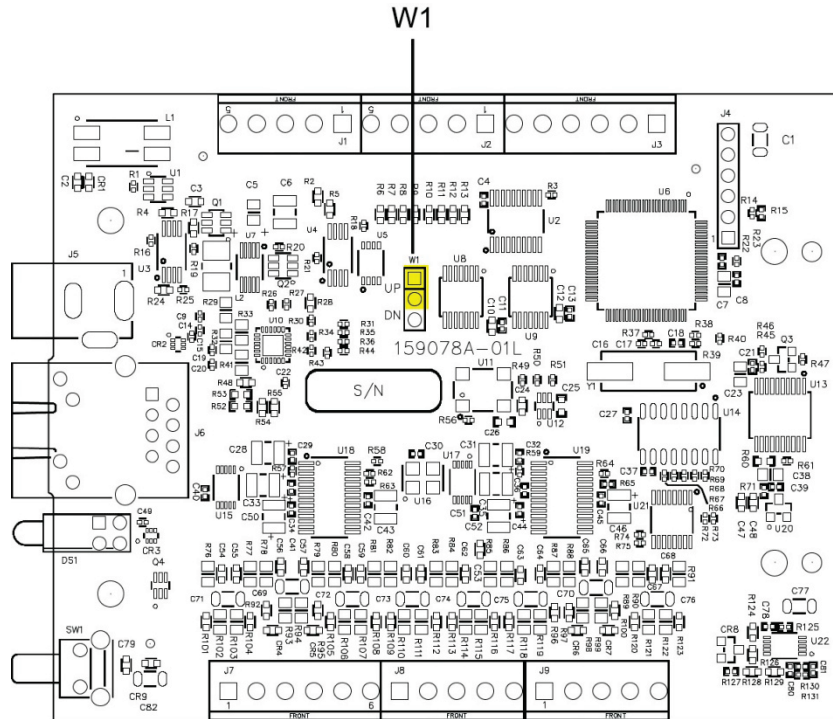

Figure 5. Pull-up/down jumper locations

Figure 6 below shows the jumper configured for pull-up and pull-down.

Caution! The discharge of static electricity can damage some electronic components. Take care when removing the enclosure. Before touching the board, ground yourself using a wrist strap or touch the computer chassis or other grounded object to eliminate any stored static charge.

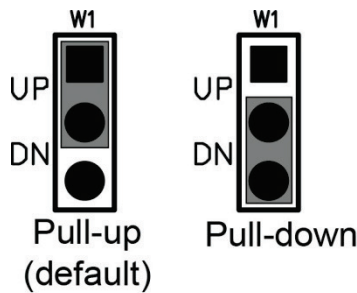

Figure 6. Pull-up/down jumper configurations, typical

For more information about digital signal connections

For general information about digital signal connections and digital I/O techniques, refer to the *Guide to DAQ Signal Connections* (available on our web site at www.mccdaq.com/support/DAQ-Signal-Connections.aspx).

When configured for input, input voltage ranges of 0 V to 5 V are permitted, with thresholds of 0.8 V (low) and 2.0 V (high). A typical digital input connection is shown in Figure 7.

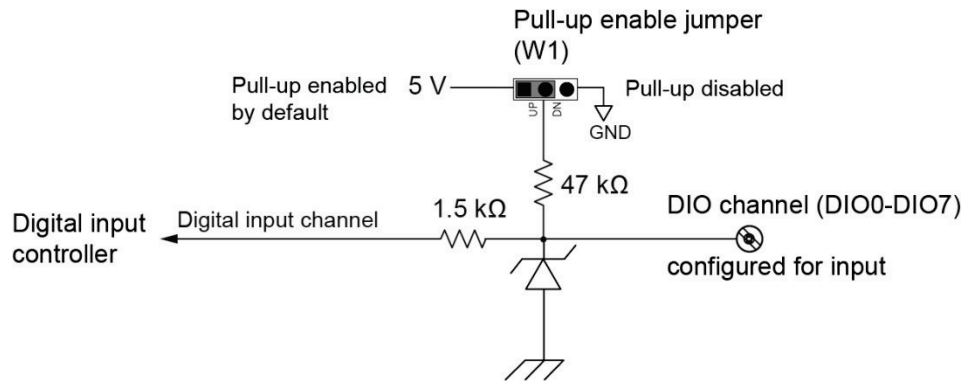

Figure 7. Digital input connection example

Temperature alarms

Optionally, you can configure each digital output as an alarm for each TC input. When an alarm is enabled, its associated output line is driven to the appropriate state determined by the alarm options and input temperature.

You can also use the alarm outputs to control a device or application that indicates when a temperature threshold has been exceeded. Alarms can also indicate an OTC condition.

A digital output bit can be used to control a logic device needing up to 5 V @ 24 mA. If the device needs more voltage/current than this, use a E-TC-controlled MOSFET¹ (user-provided) to control higher voltages and currents.

Depending on the MOSFET used, the E-TC can control higher voltages and currents.

Figure 8 shows a relay requiring 24 VDC @ 100 mA controlled by an E-TC digital output/alarm. The MOSFET in this example is a relay and is rated for 14 amps and 50 volts DC.

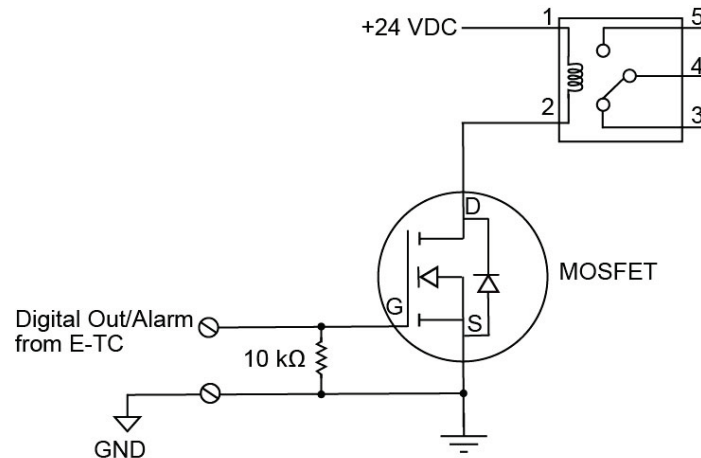

Figure 8. Example of digital output/alarm controlling a relay

The alarm configurations are stored in non-volatile memory and loaded at power up.

Alarm settings are applied when changed and at power on. Temperatures are constantly converted on enabled channels and processed for alarm conditions regardless of the communications connectivity.

¹ Metal-oxide semiconductor, field-effect transistor that uses an induced electrical field to control current through the device. Either negative or positive gate voltages can be applied to control the current.

Each available alarm mode and setting is explained below.

<p>Alarm input modes Set independent temperature thresholds T1 and T2 for each alarm.</p>	<ul style="list-style-type: none"> ■ Alarm when input temperature \geq T1, reset alarm when input temperature $<$ T2 ■ Alarm when input temperature \leq T1, reset alarm when input temperature $>$T2 ■ Alarm when input temperature is $<$ T1 or $>$ T2
<p>Alarm error modes</p>	<ul style="list-style-type: none"> ■ Alarm on temperature reading only ■ Alarm on temperature reading or open thermocouple error ■ Alarm on open thermocouple error only
<p>Alarm output modes</p>	<ul style="list-style-type: none"> ■ Disabled, digital I/O line may be used for normal operation ■ Enabled, active high output (DIO line goes high when alarm condition is met) ■ Enabled, active low output (DIO line goes low when alarm condition is met)

Counter input

The **CTR** terminal is a 32-bit event counter that can accept frequency inputs up to 10 MHz. The internal counter increments when the TTL levels transition from low to high.

Power output

The **+VO** terminal can output up to 10 mA maximum. You can use this terminal to supply power to external devices or circuitry.

Caution! The +VO terminal is an output. Do not connect it to an external power supply or you may damage the device and possibly the computer.

Ground

The digital ground (**GND**) terminals provide a common ground – isolated from TC inputs – for the digital and counter channels and the **+VO** terminal.

The chassis ground (**CHGND**) terminal provides a connection point for chassis ground. Connect this to an external grounding source.

Mechanical drawings

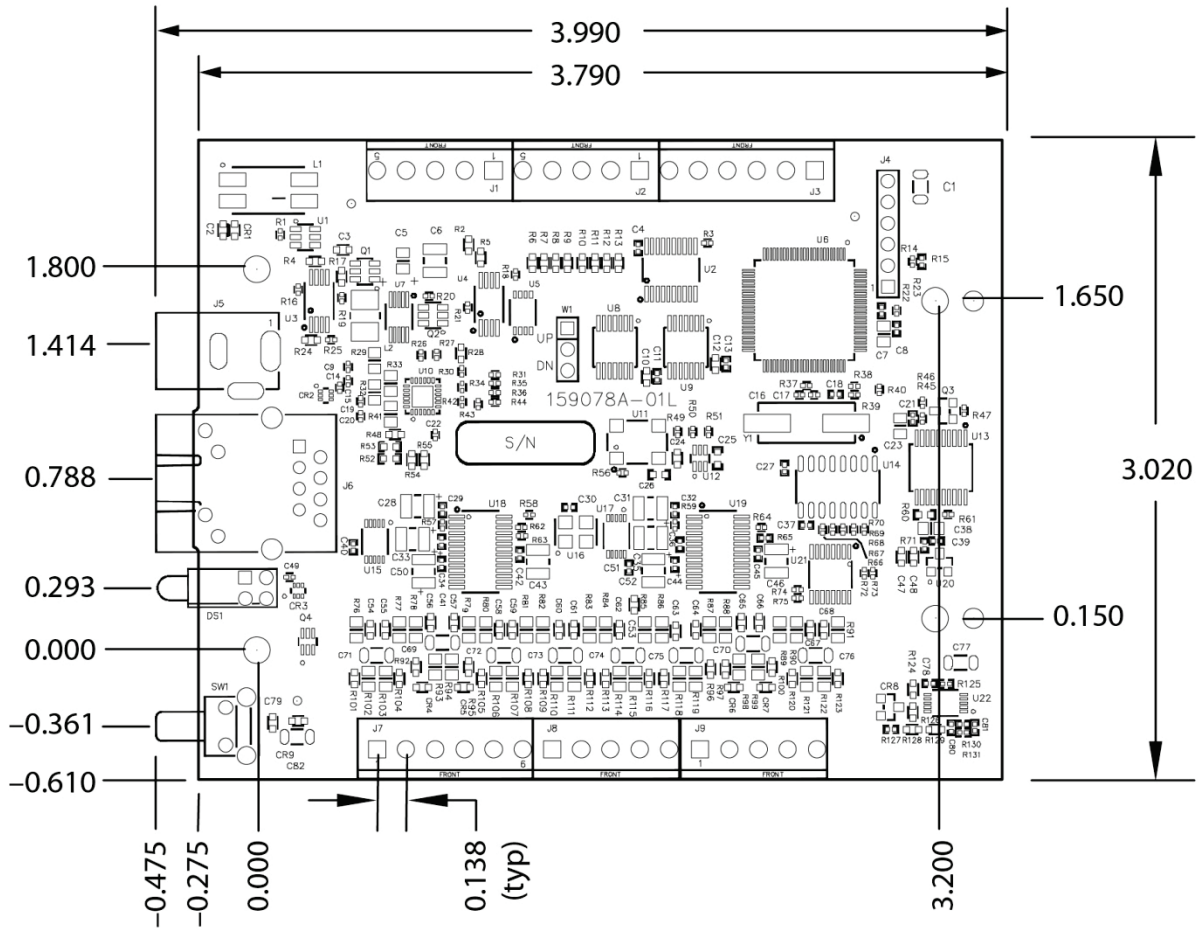

Figure 9. E-TC device circuit board dimensions

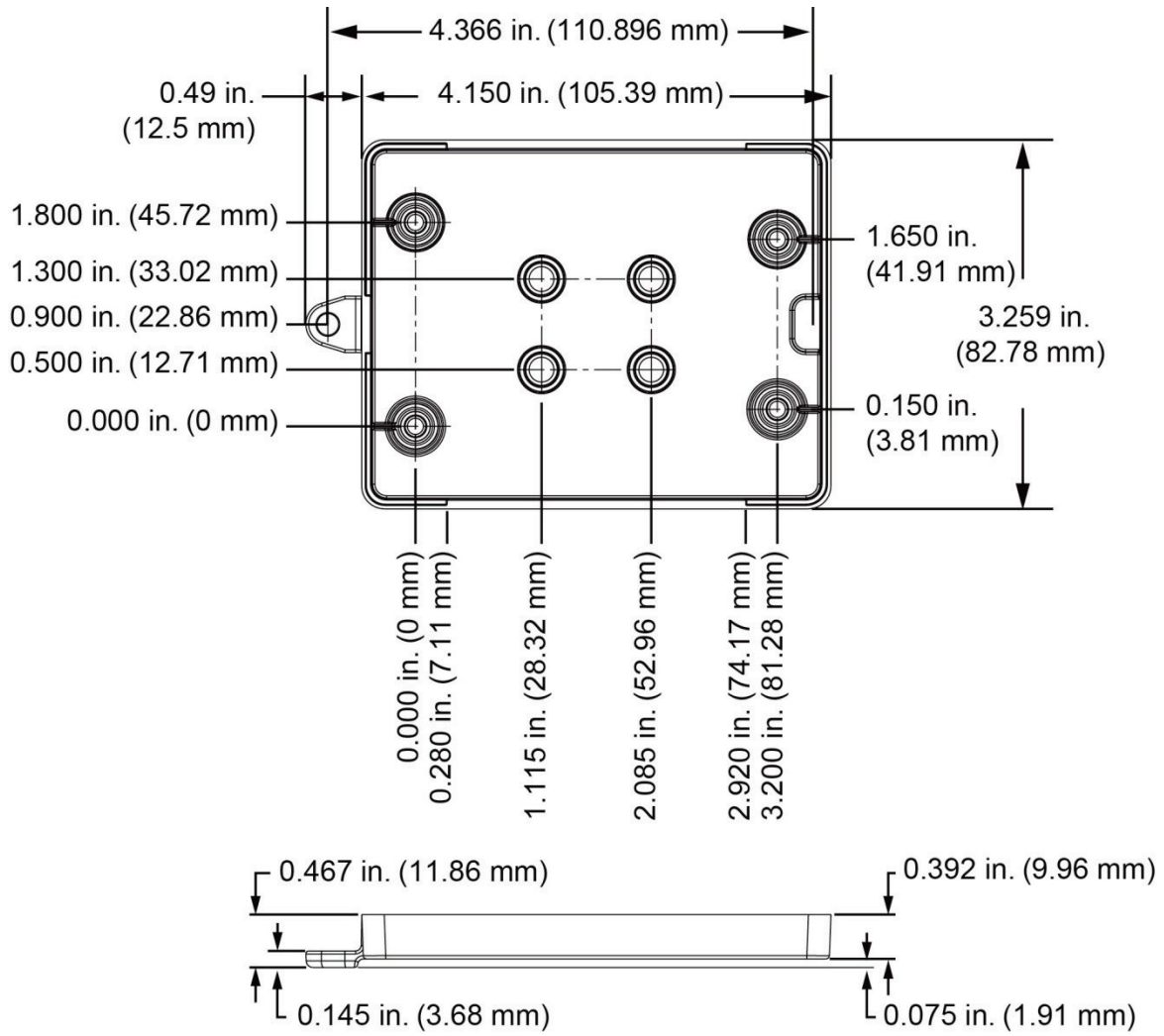

Figure 10. E-TC bottom enclosure dimensions

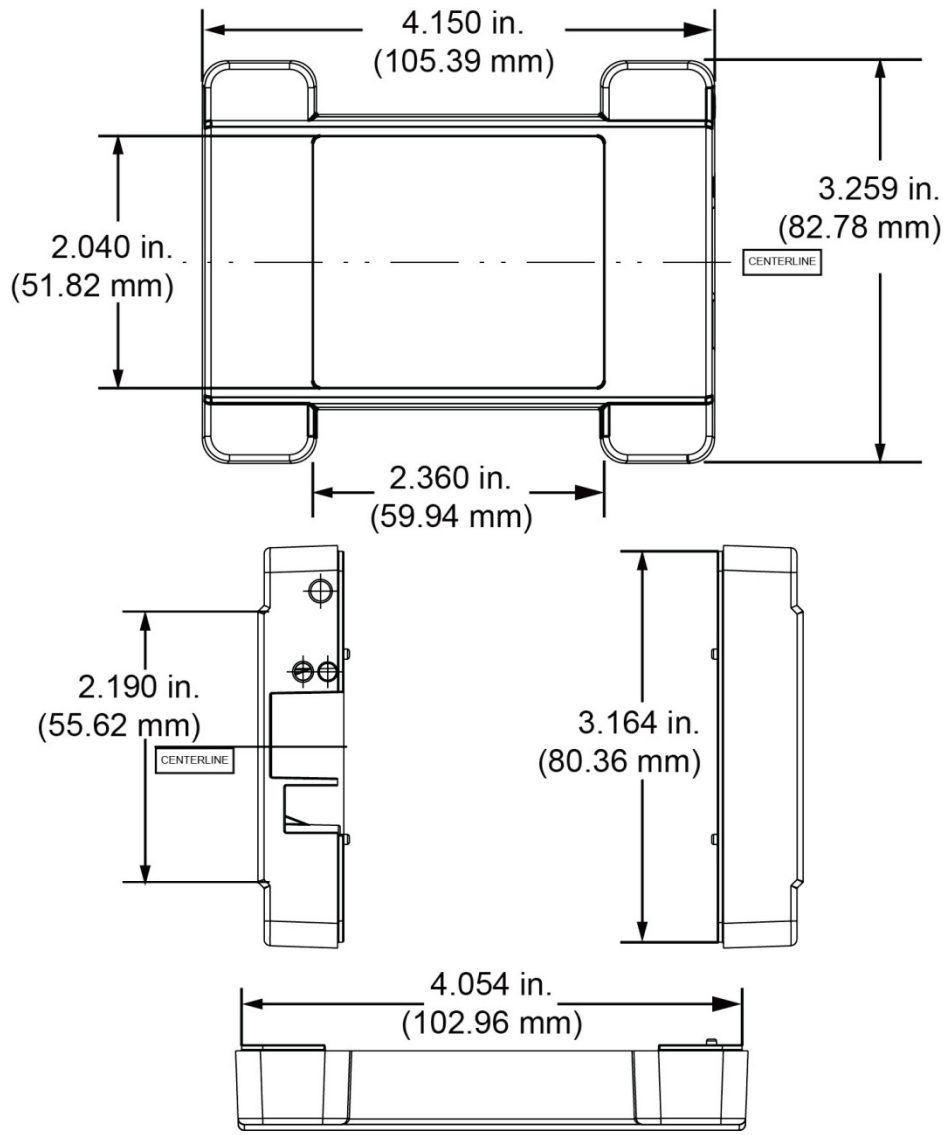

Figure 11. E-TC top enclosure dimensions

DIN-rail compatible

The E-TC can be mounted on a DIN rail using the ACC-205 DIN-rail accessory kit. Refer to our website for more information.

Specifications

All specifications are subject to change without notice.

Typical for 25 °C unless otherwise specified.

Specifications in *italic text* are guaranteed by design.

Thermocouple input

Table 1. Thermocouple input specifications

Parameter	Condition	Specification
A/D converters		Delta-Sigma
ADC resolution		24 bits
Number of channels		8
<i>Input isolation</i>	<i>Between any TCx channel and digital/chassis ground.</i>	<i>500 VDC absolute max</i>
Channel configuration		Software-selectable to match sensor type
Differential input voltage range (Note 1)		±0.128 V
<i>Absolute maximum input voltage</i>	<i>Between any two TCx inputs</i>	<i>±25 V (power on) ±25 V (power off)</i>
<i>Differential input impedance</i>		<i>40 MΩ</i>
<i>Input current</i>	<i>Open thermocouple detect disabled</i>	<i>1 nA</i>
	<i>Open thermocouple detect enabled</i>	<i>65 nA</i>
<i>Common mode rejection</i>	<i>f_{IN} = 50 Hz or 60 Hz</i>	<i>100 dB</i>
<i>Noise rejection</i>	<i>f_{IN} = 50 Hz or 60 Hz</i>	<i>75 dB</i>
Input bandwidth		10 Hz
Crosstalk	Between any two TCx inputs	-90 dB
Sample rate (Note 2)		4 Hz max (per channel)
Input noise		250 nV rms
Gain error		0.006 %
Offset error		3 μV
Measurement sensitivity (Note 3)	Thermocouple type J,K,T,E,N	0.09 °C
	Thermocouple type R,S	0.11 °C
	Thermocouple type B	0.13 °C
Warm-up time		20 minutes min
Open thermocouple detect response time		1 second
<i>CJC sensor accuracy</i>	<i>0 °C to 45 °C</i>	<i>±0.20 °C typ ±0.40 °C max</i>
Calibration method		Factory
Recommended warm-up time		20 minutes min
Calibration interval		1 year (factory calibration)

Note 1: Calibration is performed at ±70 mV.

Note 2: The enabled thermocouple inputs are continuously converted at the maximum A/D converter rate. If channels are enabled and have an open thermocouple connection the sampling rate will be lower.

Note 3: Measurement sensitivity is the smallest change in temperature that can be detected.

Channel configurations

Table 2. Channel configuration specifications

Sensor Category	Condition	Specification
Thermocouple	J, K, S, R, B, E, T, or N The factory default configuration is Type J.	8 differential channels (Note 4)

Note 4: Channel configuration is stored on EEPROM external to the isolated microcontroller by the firmware whenever any item is modified. Modification is performed by commands issued over Ethernet from an external application, and the configuration is made non-volatile through the use of the EEPROM.

Compatible thermocouples

Table 3. Compatible sensor type specifications

Parameter	Specification
Thermocouple	J: -210 °C to 1200 °C
	K: -270 °C to 1372 °C
	R: -50 °C to 1768 °C
	S: -50 °C to 1768 °C
	T: -270 °C to 400 °C
	N: -270 °C to 1300 °C
	E: -270 °C to 1000 °C
B: 0 °C to 1820 °C	

Accuracy

Thermocouple measurement accuracy

Table 4. Thermocouple accuracy specifications, including CJC measurement error (Note 5, Note 6)
All specifications are (±).

Sensor Type	Sensor Temperature (°C)	Accuracy Error Maximum (°C), 15 °C to 35 °C	Accuracy Error Typical (°C), 15 °C to 35 °C	Accuracy Error Maximum (°C), 0 °C to 45 °C	Accuracy Error Typical (°C), 0 °C to 45 °C
J	-210	1.896	0.823	2.228	0.990
	0	0.760	0.328	0.815	0.364
	1200	0.717	0.324	1.336	0.585
K	-210	2.196	0.938	2.578	1.141
	0	0.787	0.334	0.848	0.377
	1372	0.974	0.431	1.807	0.786
S	-50	2.144	0.711	2.566	1.053
	250	1.595	0.528	1.888	0.775
	1768	0.750	0.178	1.759	0.649
R	-50	2.266	0.749	2.715	1.113
	250	1.617	0.534	1.917	0.786
	1768	0.631	0.148	1.579	0.584
B	250	1.934	0.453	2.552	0.977
	700	0.740	0.179	1.128	0.439
	1820	0.482	0.137	1.213	0.492
E	-200	1.700	0.742	1.987	0.884
	0	0.752	0.327	0.806	0.360
	1000	0.629	0.285	1.142	0.500

Sensor Type	Sensor Temperature (°C)	Accuracy Error Maximum (°C), 15 °C to 35 °C	Accuracy Error Typical (°C), 15 °C to 35 °C	Accuracy Error Maximum (°C), 0 °C to 45 °C	Accuracy Error Typical (°C), 0 °C to 45 °C
T	-200	1.920	0.817	2.253	0.993
	0	0.801	0.339	0.870	0.385
	400	0.519	0.223	0.702	0.308
N	-200	2.125	0.876	2.518	1.101
	0	0.857	0.351	0.940	0.412
	1300	0.668	0.291	1.352	0.585

Note 5: Thermocouple measurement accuracy specifications include polynomial linearization, cold-junction compensation, and system noise. The accuracy specifications assume the device is operated within its enclosure and has been warmed up for the recommended 20 minutes. Errors shown do not include inherent thermocouple error. Contact your thermocouple supplier for details on the actual thermocouple accuracy error.

Note 6: When thermocouples are attached to conductive surfaces, the voltage differential between multiple thermocouples must remain within ± 1.8 V. For best results MCC recommends using electrically insulated thermocouples when possible.

Digital input/output

Table 5. Digital input/output specifications

Parameter	Specification
Digital type	5 V TTL input / CMOS output
Number of I/O	One port of 8 bits, shared with temperature alarms
Configuration	Each bit can be independently configured for input or output
Power on conditions	Power on reset is input mode, except when bits are configured to operate as alarms.
Pull-up/pull-down configuration	The port has 47 k Ω resistors configurable as pull-up (default) or pull-down via internal jumper W1.
Digital I/O transfer rate (system paced)	100 to 5000 reads / writes per second, typical, on a local network (Note 7)
Power on and reset state	All bits are input unless the temperature alarm functionality is enabled for them.
Input high voltage threshold	2.0 V min
Input high voltage limit	5.5 V absolute max
Input low voltage threshold	0.8 V max
Input low voltage limit	-0.5 V absolute min 0 V recommended min
Output high voltage	4.4 V min (IOH = -50 μ A) 3.76 V min (IOH = -24 mA)
Output low voltage	0.1 V max (IOL = 50 μ A) 0.44 V max (IOL = 24 mA)

Note 7: This is the typical throughput when the device and host are both connected by Ethernet to the same local network. Throughput can vary significantly, and typical throughput is not guaranteed, if a wireless connection is involved or data is sent over the internet.

Temperature alarms

Table 6. Temperature alarm specifications

Parameter	Specification
Number of alarms	8 (one per digital I/O line)
Alarm functionality	Each alarm controls its associated digital I/O line as an alarm output. When an alarm is enabled, its associated I/O line is set to output and driven to the appropriate state determined by the alarm options and input temperature. The alarm configurations are stored in non-volatile memory and loaded at power on.
Alarm input modes	<ul style="list-style-type: none"> ■ Alarm when input temperature $\geq T1$, reset alarm when input temperature $< T2$ ■ Alarm when input temperature $\leq T1$, reset alarm when input temperature $> T2$ ■ Alarm when input temperature is $< T1$ or $> T2$ T1 and T2 may be independently set for each alarm.
Alarm error modes	<ul style="list-style-type: none"> ■ Alarm on temperature reading only ■ Alarm on temperature reading or open thermocouple error ■ Alarm on open thermocouple error only
Alarm output modes	<ul style="list-style-type: none"> ■ Disabled, digital I/O line may be used for normal operation ■ Enabled, active high output (DIO line goes high when alarm condition is met) ■ Enabled, active low output (DIO line goes low when alarm condition is met)
Alarm latency (Note 8)	1 second

Note 8: Alarm settings are applied when changed and at power-on. Temperatures are constantly converted on enabled channels and processed for alarm conditions regardless of the communications connectivity.

Counter

Table 7. Counter specifications

Parameter	Specification
Counter type	Event counter
Number of channels	1
Input type	Schmitt trigger; fixed 47.5 k Ω pull-down resistor
Resolution	32 bits
Schmitt trigger hysteresis	0.6 V min 1.7 V max
Input high voltage threshold	1.9 V min 3.6 V max
Input high voltage limit	5.5 V absolute max
Input low voltage threshold	1.0 V min 2.3 V max
Input low voltage limit	-0.5 V absolute min 0 V recommended min
Input frequency	10 MHz max
High pulse width	50 ns min
Low pulse width	50 ns min

Memory

Table 8. Memory specifications

Parameter	Specification
EEPROM	4,096 bytes

Power

Table 9. Power specifications

Parameter	Conditions	Specification
External power supply		5 V \pm 5% required 5 V, 1 A supply provided (PS-5V1AEPS)
Supply current	Quiescent current	177 mA typical (Note 9)
User output voltage range	Available at +VO terminal	4.40 V min to 5.25 V max; assumes supplied AC adapter is used
User output current	Available at +VO terminal	10 mA max
Isolation	Measurement system to chassis ground	500 VDC min

Note 9: This is the total quiescent current requirement for the device that includes the LEDs. This value does not include any potential loading of the digital I/O bits or +VO terminal.

Network

Ethernet connection

Table 10. Ethernet connection specifications

Parameter	Specification
<i>Ethernet type</i>	100 Base-TX 10 Base-T
<i>Communication rates</i>	10/100 Mbps, auto-negotiated
<i>Connector</i>	RJ-45, 8 position
<i>Cable length</i>	100 meters (328 feet) max
<i>Additional parameters</i>	HP Auto-MDIX support

Network interface

Table 11. Factory default specifications

Parameter	Specification
Protocols used	TCP (IPv4 only) and UDP
Network ports used	UDP: 54211 (discovery) UDP: 6234 (bootloader only) TCP: 54211 (commands)
Network IP configuration	DHCP + link-local, DHCP, static, link-local
Network name	E-TC-xxxxxx, where xxxxxx are the lower 6 digits of the device MAC address
Network name publication	By NBNS; responds to b-node broadcasts, therefore only available on the local subnet

Network factory default settings

Table 12. Factory default specifications

Parameter	Specification
Factory default IP address	192.168.0.101
Factory default subnet mask	255.255.255.0
Factory default Gateway	192.168.0.1
Factory default DHCP setting	DHCP + link-local enabled

Network security

Table 13. Factory default specifications

Parameter	Specification
Security implementation	TCP sockets are not opened unless application sends the correct PIN connection code; stored in non-volatile memory; may be changed by user; default value is 0000
Number of concurrent sessions	1
Vulnerabilities	TCP Sequence Number Approximation Vulnerability

LED displays and the factory reset button

Table 14. LED and button configurations

Parameter	Specification
Power LED (top)	<ul style="list-style-type: none"> ■ On: $4.2\text{ V} < V_{\text{ext}} < 5.6\text{ V}$ ■ Off: $V_{\text{ext}} < 4.2\text{ V}$, $V_{\text{ext}} > 5.6\text{ V}$ (power fault) Power and Activity LEDs blink continuously in firmware update mode
Activity LED (bottom)	<ul style="list-style-type: none"> ■ On: A valid host connection is established. ■ Blinks: A command is received. Power and Activity LEDs blink continuously in firmware update mode
Ethernet connector LEDs	<ul style="list-style-type: none"> ■ Left (green): Link/activity indicator; on when there is a valid Ethernet link, and blinks when network activity is detected. ■ Right (yellow): Speed indicator; on for 100 Mbps, off for 10 Mbps or no link.
Factory reset button	Resets network and alarm configuration settings to factory default values. <ul style="list-style-type: none"> ■ Press and hold for 4 seconds. The Power and Activity LEDs will both blink twice and turn off to indicate that network settings have been restored to default values. Release the button to allow the device to reset and use the default settings. If the reset button is released before the two LEDs blink, settings are not affected. ■ Holding the reset button at power on forces the device into firmware update mode in case of a failed firmware update. In this mode, both LEDs blink together constantly. The device may be returned to normal operation by cycling the power.

Environment

Table 15. Environmental specifications

Parameter	Specification
Operating temperature range	0 °C to 55 °C
Storage temperature range	-40 °C to 85 °C
Humidity	0 °C to 90% non-condensing

Mechanical

Table 16. Mechanical specifications

Parameter	Specification
Dimensions (L × W × H)	117.9 × 82.8 × 29.0 mm (4.64 × 3.26 × 1.14 in.)

Screw terminal connector

Table 17. Screw terminal connector specifications

Parameter	Specification
Connector type	Screw terminal
Wire gauge range	16 AWG to 30 AWG

Table 18. Screw terminal pinout

Pin	Signal Name	Pin Description	Pin	Signal Name	Pin Description
1	CH0H	CH0 sensor input (+)	17	DIO0	DIO channel 0
2	CH0L	CH0 sensor input (-)	18	DIO1	DIO channel 1
3	CH1H	CH1 sensor input (+)	19	DIO2	DIO channel 2
4	CH1L	CH1 sensor input (-)	20	DIO3	DIO channel 3
5	CH2H	CH2 sensor input (+)	21	GND	Digital ground
6	CH2L	CH2 sensor input (-)	22	DIO4	DIO channel 4
7	CH3H	CH3 sensor input (+)	23	DIO5	DIO channel 5
8	CH3L	CH3 sensor input (-)	24	DIO6	DIO channel 6
9	CH4H	CH4 sensor input (+)	25	DIO7	DIO channel 7
10	CH4L	CH4 sensor input (-)	26	+VO	User voltage output
11	CH5H	CH5 sensor input (+)	27	GND	Digital ground
12	CH5L	CH5 sensor input (-)	28	GND	Digital ground
13	CH6H	CH6 sensor input (+)	29	GND	Digital ground
14	CH6L	CH6 sensor input (-)	30	CTR	Counter input
15	CH7H	CH7 sensor input (+)	31	GND	Digital ground
16	CH7L	CH7 sensor input (-)	32	CHGND	Chassis ground

CE Declaration of Conformity
According to ISO/IEC 17050-1:2010

Manufacturer: Measurement Computing Corporation
Address: 10 Commerce Way
Norton, MA 02766
USA
Product Category: Electrical equipment for measurement, control and laboratory use.
Date and Place of Issue: September 12, 2014, Norton, Massachusetts USA
Test Report Number: EMI6836.16

Measurement Computing Corporation declares under sole responsibility that the product

E-TC

Complies with the essential requirements of the following applicable European Directives:

Electromagnetic Compatibility (EMC) Directive 2004/108/EC
Low Voltage Directive 2006/95/EC
RoHS Directive 2011/65/EU

Conformity is assessed in accordance to the following standards:

EMC:

Emissions:

- EN 61326-1:2013 (IEC 61326-1:2012), Class A
- EN 55011: 2009 + A1:2010 (IEC CISPR 11:2009 + A1:2010), Group 1, Class A

Immunity:

- EN 61326-1:2013 (IEC 61326-1:2012), Controlled EM Environments
- EN 61000-4-2:2008 (IEC 61000-4-2:2008)
- EN 61000-4-3 :2010 (IEC61000-4-3:2010)
- EN 61000-4-4 :2012 (IEC61000-4-4:2012)
- EN 61000-4-5 :2005 (IEC61000-4-5:2005)
- EN 61000-4-6 :2013 (IEC61000-4-6:2013)
- EN 61000-4-11:2004 (IEC61000-4-11:2004)

Safety:

- EN 61010-1 (IEC 61010-1)

Environmental Affairs:

Articles manufactured on or after the Date of Issue of this Declaration of Conformity do not contain any of the restricted substances in concentrations/applications not permitted by the RoHS Directive.



Carl Haapaoja, Director of Quality Assurance

Measurement Computing Corporation
10 Commerce Way
Norton, Massachusetts 02766
(508) 946-5100
Fax: (508) 946-9500
E-mail: info@mccdaq.com
www.mccdaq.com

NI Hungary Kft
H-4031 Debrecen, Hátar út 1/A, Hungary
Phone: +36 (52) 515400
Fax: +36 (52) 515414
<http://hungary.ni.com/debrecen>