

| ITEM NO. | PART NUMBER | DESCRIPTION | QTY. |
|----------|--------------------------|--------------------------|------|
| 1 | 42 PCT | REFERENCE PCAP SCREEN | 1 |
| 2 | 20160627-141142-03547594 | 8-32 SS PEM NUT | 6 |
| 3 | AEHS8-420-165 | 1/4-20 HEX RIVNUT | 4 |
| 4 | DTS-42-LK-BASE | .25" CRS | 1 |
| 5 | DTS-42-LK-COVER | .06 CRS | 1 |
| 6 | DTS-42-LK-FANCOVER | .06 CRS | 1 |
| 7 | DTS-42-LK-LEGS | 2X6X1/8 AL RECT TUBING | 1 |
| 8 | DTS-42-LK-PAN | 12GA CRS | 1 |
| 9 | FH-632-20ZI | 6-32X1.25" ZINC PEM STUD | 4 |

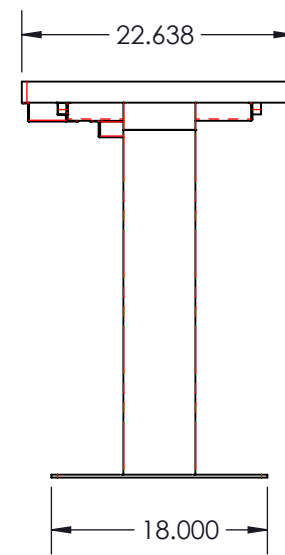
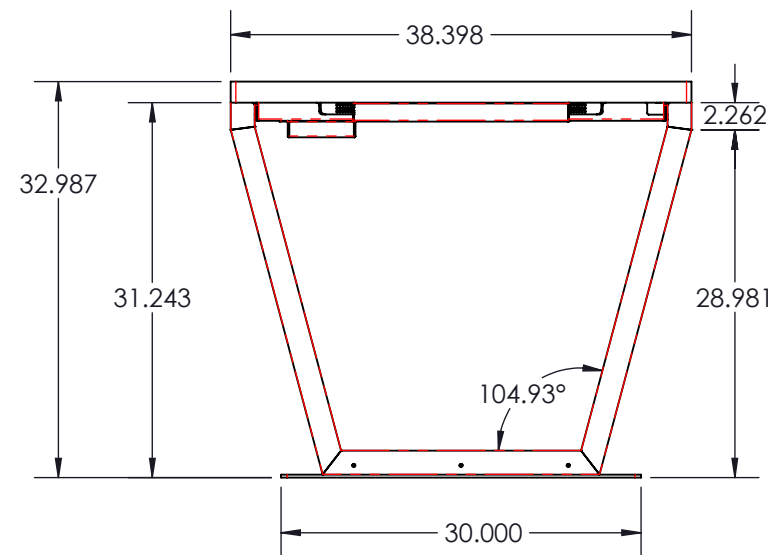
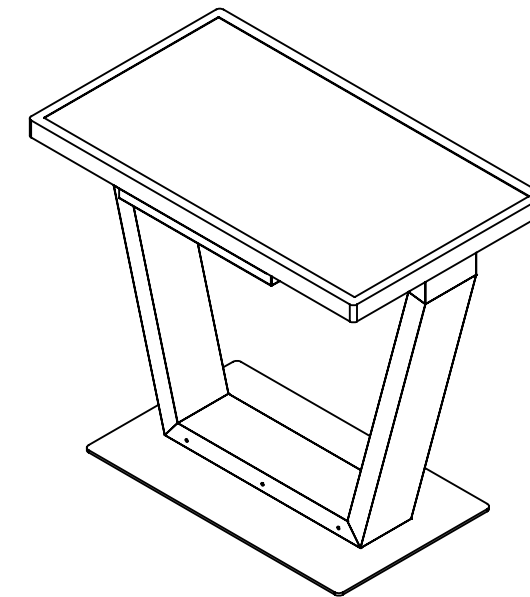
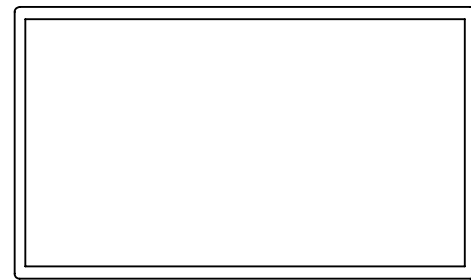

PROPRIETARY AND CONFIDENTIAL
 THE INFORMATION CONTAINED IN THIS DRAWING IS THE SOLE PROPERTY OF DIGITAL TOUCH SYSTEMS. ANY REPRODUCTION IN PART OR AS A WHOLE WITHOUT THE WRITTEN PERMISSION OF DIGITAL TOUCH SYSTEMS IS PROHIBITED.

UNLESS OTHERWISE SPECIFIED:
 DIMENSIONS ARE IN INCHES
 TOLERANCES:
 FRACTIONAL ±
 ANGULAR: MACH ± BEND ±
 TWO PLACE DECIMAL ±
 THREE PLACE DECIMAL ±
 INTERPRET GEOMETRIC TOLERANCING PER:
 MATERIAL
 FINISH
 DO NOT SCALE DRAWING

| | NAME | DATE |
|-----------|------|----------|
| DRAWN | BCP | 2/2/2017 |
| CHECKED | XXX | XX-XX-XX |
| ENG APPR. | XXX | XX-XX-XX |
| MFG APPR. | | |
| Q.A. | | |
| COMMENTS: | | |

DigitalTouch
Signatures

TITLE:

| | | |
|------------------|-----------------------|----------|
| SIZE B | DWG. NO. DTS-42-LK | REV 1 |
|------------------|-----------------------|----------|

SCALE: 1:16 LBS: SHEET 1 OF 4

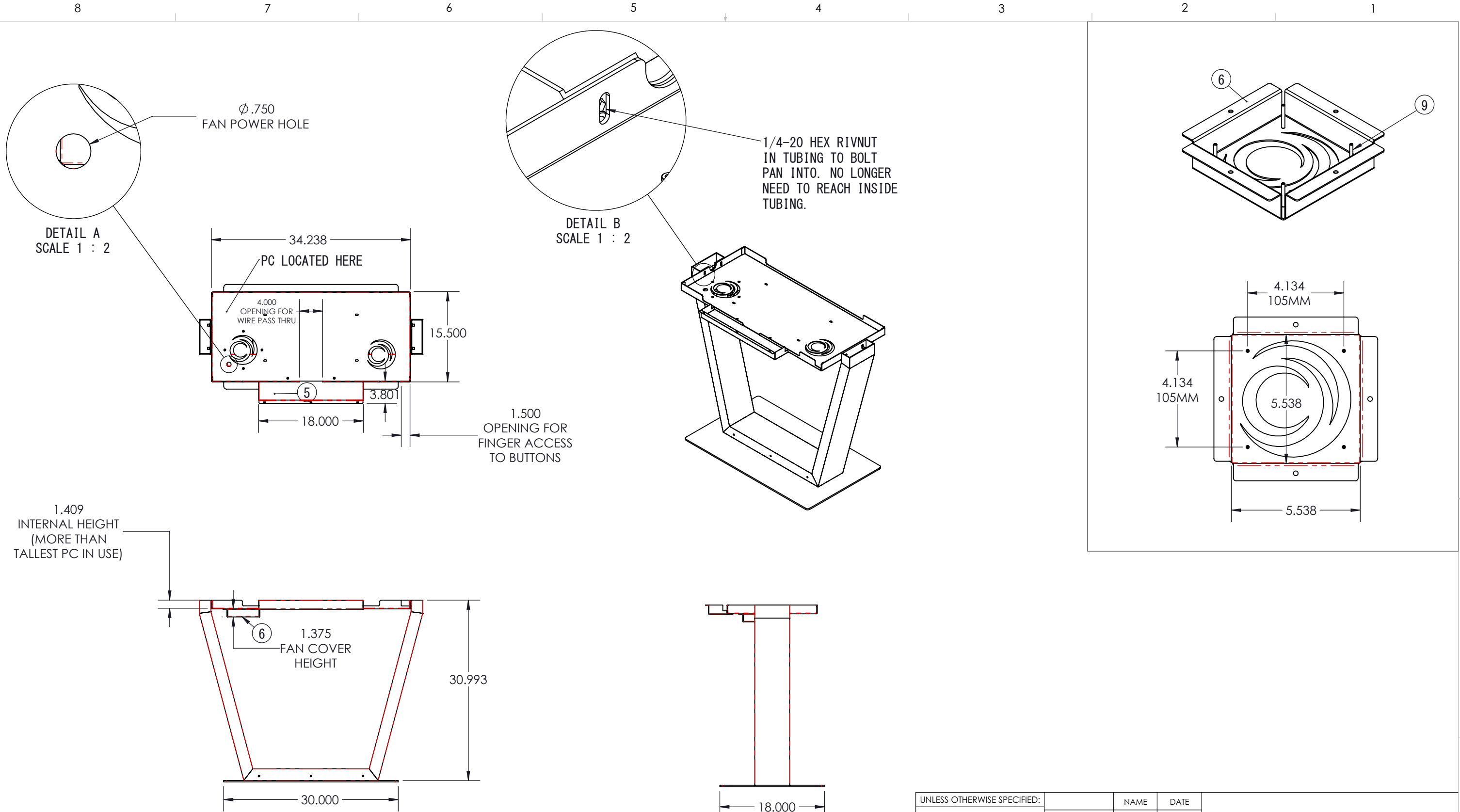

PROPRIETARY AND CONFIDENTIAL
 THE INFORMATION CONTAINED IN THIS DRAWING IS THE SOLE PROPERTY OF DIGITAL TOUCH SYSTEMS. ANY REPRODUCTION IN PART OR AS A WHOLE WITHOUT THE WRITTEN PERMISSION OF DIGITAL TOUCH SYSTEMS IS PROHIBITED.

UNLESS OTHERWISE SPECIFIED:
 DIMENSIONS ARE IN INCHES
 TOLERANCES:
 FRACTIONAL \pm
 ANGULAR: MACH \pm BEND \pm
 TWO PLACE DECIMAL \pm
 THREE PLACE DECIMAL \pm

INTERPRET GEOMETRIC TOLERANCING PER:
 MATERIAL
 FINISH
 DO NOT SCALE DRAWING

| | NAME | DATE |
|-----------|------|------|
| DRAWN | | |
| CHECKED | | |
| ENG APPR. | | |
| MFG APPR. | | |
| Q.A. | | |
| COMMENTS: | | |

| | | |
|------------------|-----------------------|--------------|
| TITLE: | | |
| SIZE B | DWG. NO. DTS-42-LK | REV |
| SCALE: 1:16 | WEIGHT: | SHEET 2 OF 4 |

8 7 6 5 4 3 2 1

| ITEM NO. | PART NUMBER | DESCRIPTION | QTY. |
|----------|--------------------------|--------------------------|------|
| 1 | 42 PCT | REFERENCE PCAP SCREEN | 1 |
| 2 | 20160627-141142-03547594 | 8-32 SS PEM NUT | 6 |
| 3 | AEHS8-420-165 | 1/4-20 HEX RIVNUT | 8 |
| 4 | DTS-42-LK-BASE | .25" CRS | 1 |
| 5 | DTS-42-LK-COVER | .06 CRS | 1 |
| 6 | DTS-42-LK-FANCOVER | .06 CRS | 1 |
| 7 | DTS-42-LK-LEGS | 2X6X1/8 AL RECT TUBING | 1 |
| 8 | DTS-42-LK-PAN | 12GA CRS | 1 |
| 9 | DTS-42-LK-SLANT-1 | 1/8" AL | 1 |
| 10 | DTS-42-LK-SLANT-2 | 2X6X1/8 AL RECT TUBING | 1 |
| 11 | DTS-42-LK-SLANT-3 | 2X6X1/8 AL RECT TUBING | 1 |
| 12 | DTS-42-LK-SLANT-4 | 1/8" AL | 1 |
| 13 | FH-632-20ZI | 6-32X1.25" ZINC PEM STUD | 4 |

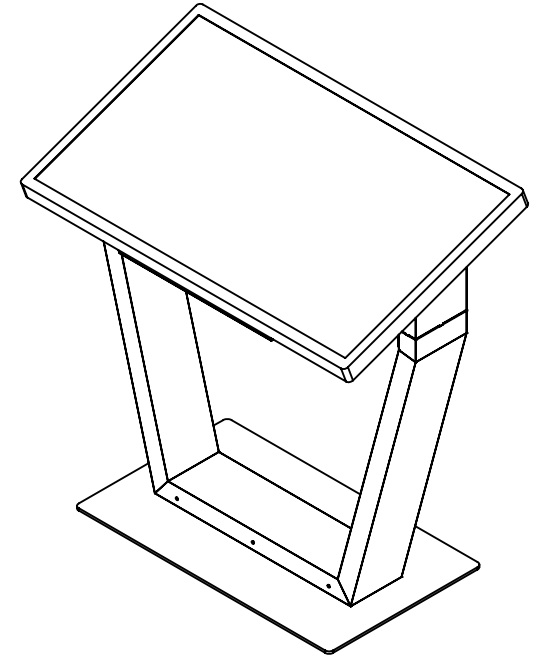
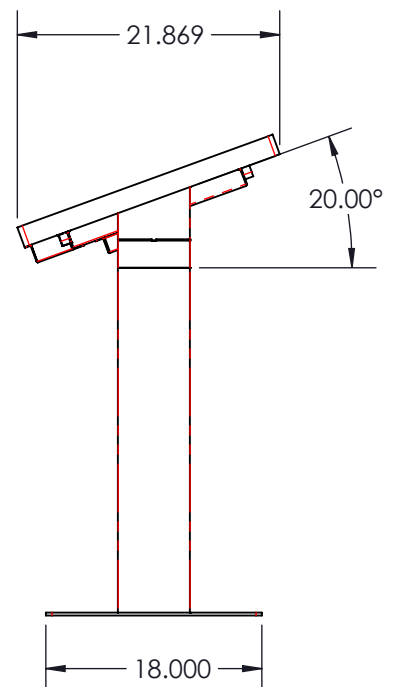
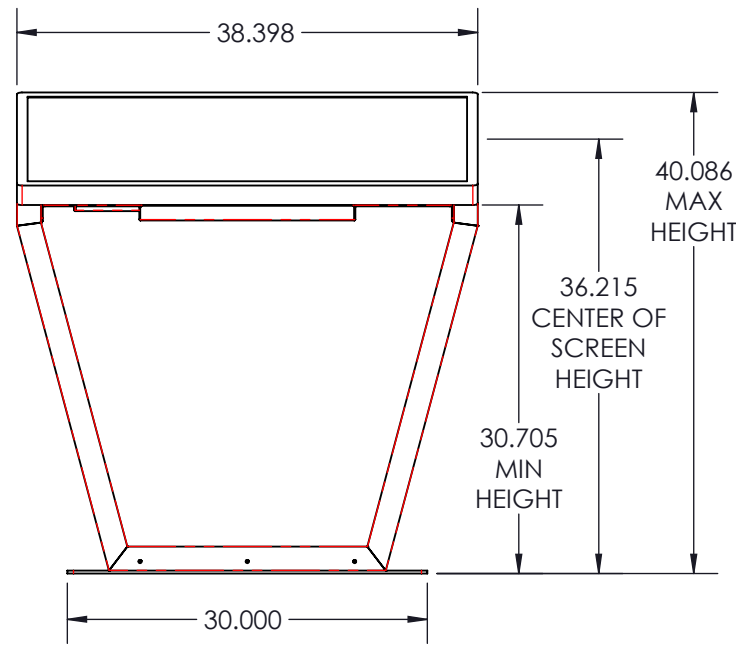
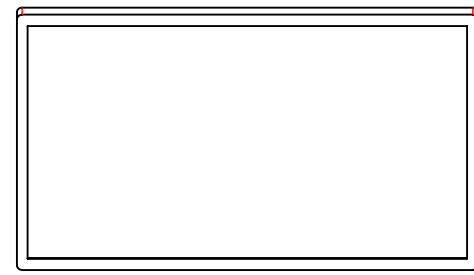

D
C
B
A

D
C
B
A

8 7 6 5 4 3 2 1

PROPRIETARY AND CONFIDENTIAL
 THE INFORMATION CONTAINED IN THIS DRAWING IS THE SOLE PROPERTY OF DIGITAL TOUCH SYSTEMS. ANY REPRODUCTION IN PART OR AS A WHOLE WITHOUT THE WRITTEN PERMISSION OF DIGITAL TOUCH SYSTEMS IS PROHIBITED.

UNLESS OTHERWISE SPECIFIED:
 DIMENSIONS ARE IN INCHES
 TOLERANCES:
 FRACTIONAL ±
 ANGULAR: MACH ± BEND ±
 TWO PLACE DECIMAL ±
 THREE PLACE DECIMAL ±
 INTERPRET GEOMETRIC TOLERANCING PER:
 MATERIAL
 FINISH
 DO NOT SCALE DRAWING

| | NAME | DATE |
|-----------|------|------|
| DRAWN | | |
| CHECKED | | |
| ENG APPR. | | |
| MFG APPR. | | |
| Q.A. | | |
| COMMENTS: | | |

| | | |
|------------------|-----------------------|--------------|
| TITLE: | | |
| SIZE B | DWG. NO. DTS-42-LK | REV |
| SCALE: 1:16 | WEIGHT: | SHEET 3 OF 4 |

8 7 6 5 4 3 2 1

D
C
B
A

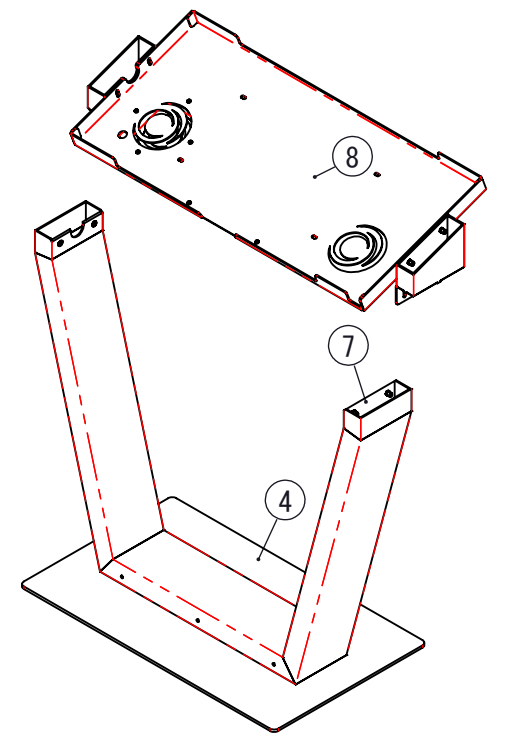
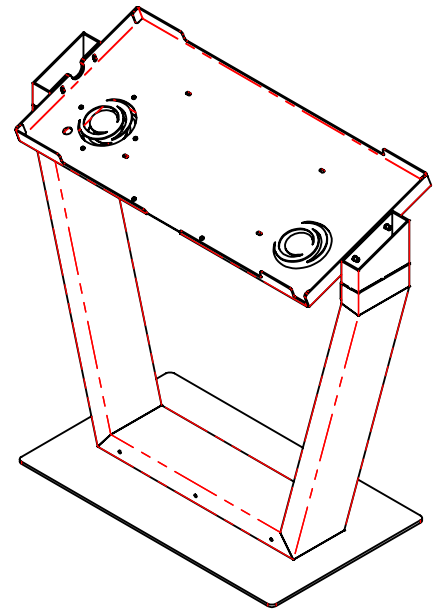
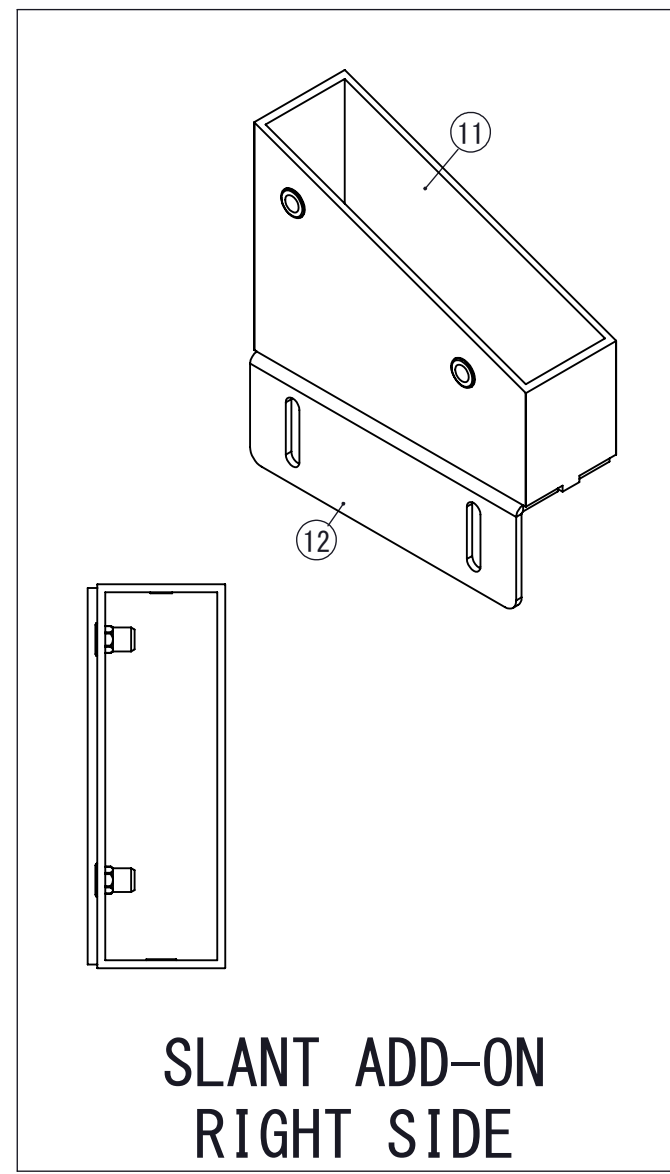
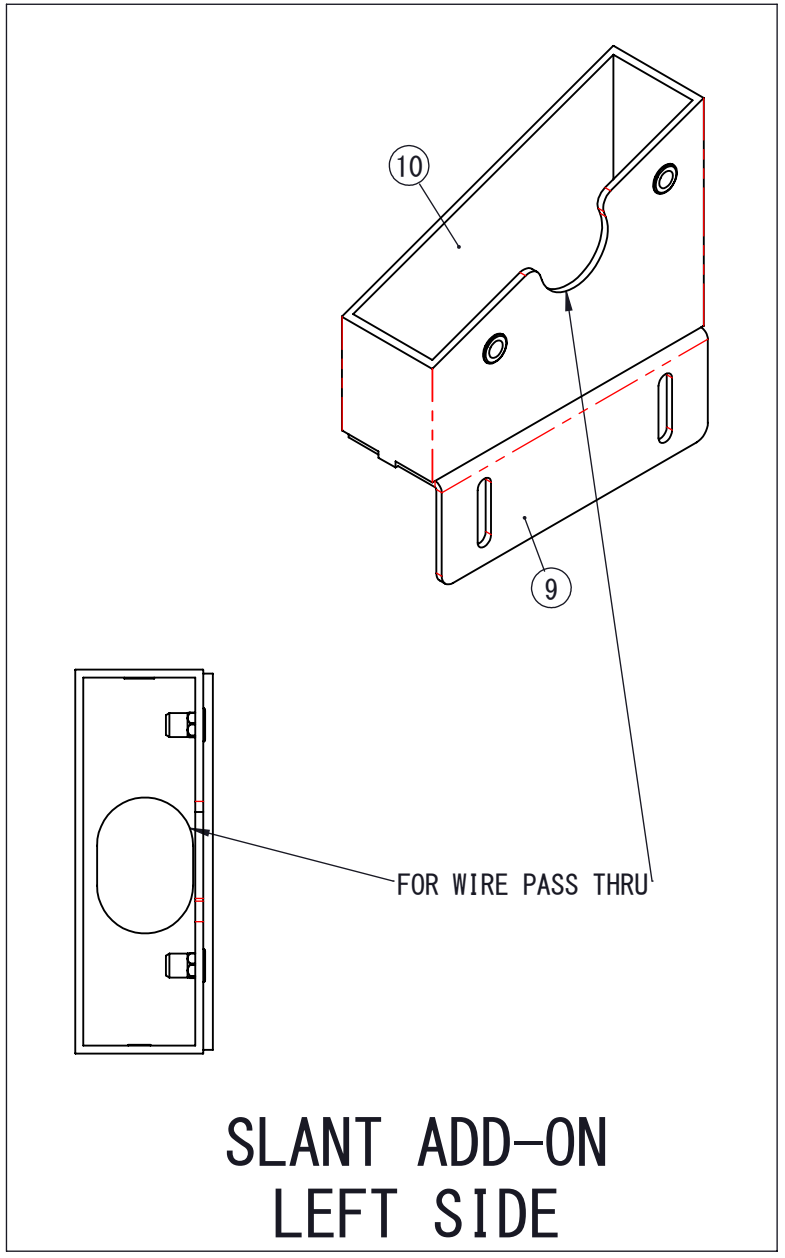

D
C
B
A

PROPRIETARY AND CONFIDENTIAL
THE INFORMATION CONTAINED IN THIS DRAWING IS THE SOLE PROPERTY OF DIGITAL TOUCH SYSTEMS. ANY REPRODUCTION IN PART OR AS A WHOLE WITHOUT THE WRITTEN PERMISSION OF DIGITAL TOUCH SYSTEMS IS PROHIBITED.

| | | | |
|--------------------------------------|--|-----------|------|
| UNLESS OTHERWISE SPECIFIED: | | NAME | DATE |
| DIMENSIONS ARE IN INCHES | | DRAWN | |
| TOLERANCES: | | CHECKED | |
| FRACTIONAL ± | | ENG APPR. | |
| ANGULAR: MACH ± BEND ± | | MFG APPR. | |
| TWO PLACE DECIMAL ± | | Q.A. | |
| THREE PLACE DECIMAL ± | | COMMENTS: | |
| INTERPRET GEOMETRIC TOLERANCING PER: | | | |
| MATERIAL | | | |
| FINISH | | | |
| DO NOT SCALE DRAWING | | | |

| | |
|-------------|-----------|
| TITLE: | |
| SIZE | DWG. NO. |
| B | DTS-42-LK |
| SCALE: 1:16 | WEIGHT: |

| | |
|--------------|--|
| REV | |
| SHEET 4 OF 4 | |

8 7 6 5 4 3 2 1