

PCAP Touch Screen Displays

User Manual

Features

- ▶ Supports Resolutions up to 1920x1080
- ▶ Digital Character Smoothing
- ▶ Automatic Set-up
- ▶ Stereo Speakers 2 x 7W Stereo Speakers
- ▶ Plug & Play VESA DDC2B Compliant
Windows XP/Vista/7/8/10 Compliant
- ▶ Power Management (VESA DPMS Compliant)
- ▶ VESA Mounting Standard (400mm~200mm)
Compliant : DTS-3250LA/DTS4240LL/
DTS-4650LA
- ▶ VESA Mounting Standard (600mm~400mm)
Compliant : DTS-5541LL
- ▶ IPX1 Standard Compliant (Only front face)

Thank you for purchasing our product.

This manual describes how to use the product and notes in use.
Please read the manual carefully before using it.
After reading this manual, please retain for future reference.

If you have any questions or a problem occurs, please contact either the company you purchased this product from or an authorized service center.

- ※ **Displaying static picture for an extended period of time may cause burn-in effect.**
- ※ **Burn-in effect and the faults in brightness and picture elements caused by fixed images are not subject to the warranty coverage.**



Warning

If you fail to comply with the regulations for safety and proper use, fire or injury may be caused.



Warning

To prevent electric shock, Do not remove cover.
No user serviceable part inside.
Refer servicing to qualified service personal.

Supplied Accessories



Power Cable



HDMI Cable



USB Cable



Remote Controller



CR2032 Battery



IR Receiver

Notice to users

Class A digital device



It is a device designed for business purpose with a safety certificate for electromagnetic interference, which user should be mindful of.

" Important Safety Instructions"

- 1) Read these instructions.
- 2) Keep these instructions.
- 3) Heed all warnings.
- 4) Follow all instructions.
- 5) Do not use this apparatus near water.
- 6) Clean only with dry cloth.
- 7) Do not block any ventilation openings. Install in accordance with the manufacturer's instructions.
- 8) Do not install near any heat sources such as radiators, heat registers, stoves, or other apparatus (including amplifiers) that produce heat.
- 9) Do not defeat the safety purpose of the polarized or grounding-type plug. A polarized plug has two blades with one wider than the other. A grounding type plug has two blades and a third grounding prong. The wide blade or the third prong are provided for your safety. If the provided plug does not fit into your outlet, consult an electrician for replacement of the obsolete outlet.
- 10) Protect the power cord from being walked on or pinched particularly at plugs, convenience receptacles, and the point where they exit from the apparatus.
- 11) Only use attachments/accessories specified by the manufacturer.
- 12) Use only with the cart, stand, tripod, bracket, or table specified by the manufacturer, or sold with the apparatus. When a cart is used, use caution when moving the cart/apparatus combination to avoid injury from tip-over.
- 13) Unplug this apparatus during lightning storms or when unused for long periods of time.
- 14) Refer all servicing to qualified service personnel. Servicing is required when the apparatus has been damaged in any way, such as power-supply cord or plug is damaged, liquid has been spilled or objects have fallen into the apparatus, the apparatus has been exposed to rain or moisture, does not operate normally, or has been dropped.



Contents

	CAUTION RISK OF ELECTRIC SHOCK DO NOT OPEN	
CAUTION : TO REDUCE THE RISK OF ELECTRIC SHOCK, DO NOT REMOVE COVER (OR BACK). NO USER-SERVICEABLE PARTS INSIDE. REFER SERVICING TO QUALIFIED SERVICE PERSONNEL.		



This symbol is intended to alert the user to the presence of uninsulated "dangerous voltage" within the product's enclosure that may be of sufficient magnitude to constitute a risk of electric shock to persons.



This symbol is intended to alert the user to the presence of important operating and maintenance(servicing) instructions in the literature accompanying the appliance.

NOTICE

1. To disconnect the apparatus from the mains, the plug must be pulled out from the mains socket, therefore the mains plug shall be readily operable.
2. WARNING - To Reduce The Risk Of Fire Or Electric Shock, Do Not Expose This Appliance To Rain Or Moisture.
3. Apparatus shall not be exposed to dripping or splashing and no objects filled with liquids, such as vases, shall be placed on the apparatus.
4. Use only a properly grounded plug and receptacle.
5. "Warning" CAUTION – These servicing instructions are for use by qualified service personnel only. To reduce the risk of electric shock, do not perform any servicing other than that contained in the operating instructions unless you are qualified to do so.
6. "Warning" CAUTION – These servicing instructions are for use by qualified service personnel only. To reduce the risk of electric shock, do not perform any servicing other than that contained in the operating instructions unless you are qualified to do so.













※ European Union Disposal Information	4
※ Cautions for consisting	5
※ Special Notes On Lcd Monitors	6
※ Customer Service	6
※ Cleaning	7
※ Ergonomic Recommendations	7
1. Safety Precautions	8
2. Unpacking	10
3. Installation	11
3.1. WALL MOUNTING	11
3.2. FAN	11
3.3. ROTATING THE DISPLAY	11
4. Names	12
5. Remote Control	14
5.1. PREPARING THE REMOTE CONTROL	15
5.2. BASIC OPERATION	16
6. How to Connect Cables	18
7. Computer Setting	20
8. Operating The Monitor	21
9. Adjustment Menu Contents	23
9.1. Brightness/Contrast	23
9.2. Color Settings	23
9.3. Display Settings	24
9.4. Other Settings	25
9.5. Schedule Settings	26
9.6. Input Source	27
9.7. Information	27
10. Power Management Feature	28
11. Trouble Shooting	29

❌ European Union Disposal Information

❌ Cautions for consisting

WARNING

WARNING

English	Français	Deutsch
<p>Disposal of old Electrical & Electronic Equipment (Applicable throughout the European Union and other European countries with separate collection programs)</p> <p>This symbol found on your product or on its packaging, indicates that this product should not be treated as household waste when you wish to dispose of it. Instead, it should be handed over to an applicable collection point for the recycling of electrical and electronic equipment. By ensuring this product is disposed of correctly, you will help prevent potential negative consequences to the environment and human health, which could otherwise be caused by inappropriate disposal of this product. The recycling of materials will help to conserve natural resources.</p>  <p>This symbol is only valid in the European Union. If you wish to discard this product, please contact your local authorities or dealer and ask for the correct method of disposal.</p>	<p>Mise au rebut des équipements électriques et électroniques usagés (Valable dans l'ensemble de l'Union Européenne ainsi que dans les pays européens disposant de programmes distincts de collecte des déchets)</p> <p>Ce symbole appliqué sur votre produit ou sur son emballage indique que ce produit ne doit pas être traité comme un déchet ménager lorsque vous voulez le mettre au rebut. Il doit au contraire être remis à un site de collecte agréé pour le recyclage des équipements électriques et électroniques. En veillant à ce que ce produit soit mis au rebut de façon adéquate, vous contribuerez à prévenir les conséquences potentiellement négatives sur l'environnement et sur la santé humaine qui risqueraient de se produire en cas de mise au rebut inappropriée de ce produit. Le recyclage des matériaux contribuera également à économiser les ressources naturelles.</p>  <p>Ce symbole n'est valable que dans l'Union Européenne. Si vous souhaitez mettre ce produit au rebut, veuillez prendre contact avec les autorités locales ou avec votre revendeur et renseignez-vous sur la méthode de mise au rebut correcte.</p>	<p>Entsorgung von elektrischen & elektronischen Altgeräten (geltend für die europäische Gemeinschaft und andere europäische Länder mit separaten Sammelprogrammen)</p> <p>Dieses Symbol, zu finden auf Ihrem Produkt oder dessen Verpackung, macht Sie darauf aufmerksam, dass dieses Produkt bei der Entsorgung nichts als Hausmüll behandelt werden darf. Stattdessen sollte es an eine Sammelstelle zum Recycling von elektrischen und elektronischen Altgeräten gegeben werden. Helfen Sie mit, potenziell schädliche Einflüsse auf Umwelt und Gesundheit, die durch eine unsachgemäße Entsorgung dieses Produktes entstehen können, zu vermeiden und entsorgen Sie dieses Produkt ordnungsgemäß. Recycling hilft, natürliche Rohstoffe einzusparen.</p>  <p>Dieses Symbol ist nur innerhalb der europäischen Gemeinschaft gültig. Wenn Sie dieses Produkt entsorgen möchten, wenden Sie sich bitte an Ihre örtliche Behörde und fragen Sie nach der ordnungsgemäßen Entsorgungsmethode.</p>
<p>Deshecho de equipos eléctricos y electrónicos (aplicable a la Europea y a otros países europeos con programas de reciclaje independientes)</p> <p>La presencia de este símbolo en el propio producto o en su material embalaje, indica que no se debe tratar como residuo doméstico dese de deshacerse de él. En su lugar, debe entregarlo en el punto correspondiente de reciclaje de equipos eléctricos y electrónicos. Asegurándose de que este producto se desecha de forma correcta, ayudará a evitar posibles consecuencias negativas para la conservación del medioambiente y la salud humana, consecuencias que podrían darse si se producto de forma inadecuada. El reciclado de materiales ayuda a conservar los recursos naturales.</p>  <p>Este símbolo solamente es válido en la Unión Europea. Si desea deshacerse de este producto, póngase en contacto con las autoridades locales o con su distribuidor y pida información sobre el método de disposición adecuado.</p>	<p>Smaltimento delle attrezzature elettriche ed elettroniche usate (applicabile in tutta la Comunità Europea ed altri Paesi Europei che applicano programmi di raccolta differenziata)</p> <p>Il simbolo trovato sul prodotto, o sulla sua confezione, indica che il prodotto non può essere trattato come i domestici quando è il momento di smaltirlo. Al contrario, deve essere consegnato ad un centro di raccolta specializzato nel riciclaggio di attrezzature elettriche ed elettroniche. Assicurando che il corretto smaltimento di questo prodotto, si aiuterà a prevenire potenziali conseguenze negative sull'ambiente e sulla salute umana, che possono essere provocate da uno scorretto smaltimento di questa attrezzatura. I materiali riciclati aiuteranno a conservare le risorse naturali.</p>  <p>Questo simbolo è valido solo nell'Unione Europea. Per smaltire questo prodotto, mettersi in contatto con le autorità locali – o con il rivenditore – e chiedere informazioni sul corretto metodo di smaltimento.</p>	<p>Verwijderen van oude elektrische en elektronische apparatuur Unie (toepasselijk in de volledige Europese Unie en andere Europese landen met afzonderlijke programma's voor afvalverzameling)</p> <p>Dit symbool dat op het product of zijn verpakking is aangebracht, geeft aan de dat dit product niet mag worden behandeld als huishoudelijk afval als u het cuando wilt wegwerpen. U moet het afgeven bij een specifiek verzamelpunt voor de limpio recyclage van elektrische en elektronische apparatuur. Door te garanderen dat u dit product op de correcte manier wegwerpt, helpt u potentiële negatieve gevolgen voor het milieu en de menselijke gezondheid, die zouden kunnen worden veroorzaakt door een onrechtmatig wegwerpen van het deshaec del product, te voorkomen. De recyclage van materialen helpt het behoud van natuurlijke bronnen.</p>  <p>Dit symbool is alleen geldig in de Europese Unie. Als u dit product wenst weg te gooien, dient u contact op te nemen met uw lokale instanties voor details over de gepaste methode voor afvalverwijdering.</p>
<p>Eliminação de equipamentos eléctricos e electrónicos usados (aplicável na União Europeia e noutros países europeus com programas próprios de recolha destes equipamentos)</p> <p>Este símbolo, colocado no produto ou na respectiva embalagem, indica que o produto não deve ser tratado como lixo doméstico aquando da sua eliminação. Em vez disso, deve ser entregue num ponto de recolha de equipamentos eléctricos e electrónicos para posterior reciclagem. Ao garantir a correcta eliminação deste produto, estará a evitar consequências potencialmente negativas tanto para o ambiente como para a saúde humana. A reciclagem de materiais ajuda a preservar os recursos naturais.</p>  <p>Este símbolo apenas é válido na União Europeia. Se quiser eliminar este produto, contacte as entidades locais ou o seu fornecedor para ficar a saber qual o método de eliminação correcto.</p>	<p>Usuwanie zużytego sprzętu elektrycznego i elektronicznego (Dotyczy krajów Unii Europejskiej i innych krajów europejskich z oddzielnymi programami zbiórki odpadów)</p> <p>Obecność tego symbolu na produkcie lub na opakowaniu z produktem oznacza, że tego produktu nie można wyrzucić razem z odpadkami domowymi. Należy go przekazać do punktu zbiórki w celu poddania recyklingowi podzespołów elektrycznych i elektronicznych. Usunięcie tego produktu w prawidłowy sposób, pomoże w zabezpieczeniu przed negatywnym wpływem odpadów na środowisko i zdrowie ludzi, powodowanym przez niewłaściwe usuwanie produktu. Przetwarzanie materiałów pomaga w zachowaniu zasobów naturalnych.</p>  <p>Ten symbol obowiązuje wyłącznie w krajach Unii Europejskiej. Informacje dotyczące prawidłowej metody usunięcia tego produktu, można uzyskać u władz lokalnych lub u dostawcy.</p>	<p>Waste Electrical and Electronic Equipment (WEEE) Directive In the European Union, this label indicates that this product should not be disposed of with household waste. It should be deposited at an appropriate facility to enable recovery and recycling. EEE complies with Directive 'Regulation on the Restriction of the Use of Certain Hazardous Substances in Electrical and Electronic Equipment'</p>  <p>Waste Electrical and Electronic Equipment (WEEE) Directive In the European Union, this label indicates that this product should not be disposed of with household waste. It should be deposited at an appropriate facility to enable recovery and recycling. EEE complies with Directive 'Regulation on the Restriction of the Use of Certain Hazardous Substances in Electrical and Electronic Equipment'</p>
<p>Avfall av förbrukad elektrisk och elektronisk utrustning (Tillämpbart i hela Europeiska unionen och andra europeiska länder med separata samlingsprogram)</p> <p>Den här symbolen som finns på din produkt eller på dess förpackning påvisar att produkten inte ska behandlas som hushållsavfall när du vill slänga bort den. Istället ska den lämnas över till en lämplig uppsamlingspunkt för återvinning av elektriska och elektroniska utrustningar. Genom att tillförsäkra att den här produkten återvinns på ett riktigt sätt hjälper du till med att förhindra möjliga negativa konsekvenser för miljön och mänsklig hälsa. Det kan annars orsakas på grund av olämplig sophantering av den här produkten. Återvinning av material kommer att hjälpa till att bevara naturtillgångar.</p>  <p>Den här symbolen är endast giltig inom den Europeiska unionen. Om du vill slänga bort den här produkten ska du kontakta lokala myndigheter eller återförsäljare, och fråga efter lämplig avfallsmetod</p>	<p>Vanhojen sähkö- ja elektroniikkalaitteiden hävittäminen (Soveltuva kaikkialla Euroopan unionin alueella, sekä muissa Euroopan maissa, joilla on erilliset keräysohjelmat)</p> <p>Jos tuotteessa tai sen pakkauksessa on tämä symboli, sitä ei pidä hävittää tavalliseen tavalliseen kotitalousjätteeseen, vaan se kuuluu toimittava sähkö- ja elektroniikkalaitteiden kierrätysjärjestelmään. Varmistamalla, että tämä tuote hävitetään asianmukaisesti, autat estämään mahdollisia ympäristölle ja ihmisille koituvia negatiivisia seurauksia, joita sen väärinlainen hävittäminen voi aiheuttaa. Materiaalien kierrättäminen auttaa säilyttämään luonnonvarjoja.</p>  <p>Tämä symboli on voimassa ainoastaan Euroopan unionin alueella. Jos haluat hävittää tämän tuotteen, ota yhteyttä paikallisiin viranomaisiin tai jälleenmyyjään ja tiedustele asiaankuuluvia hävittämistimenpiteitä.</p>	<p>Waste Electrical and Electronic Equipment (WEEE) Yönergeleri Avrupa Birliği'nde bu etiket, ürünün ev elektroniği aletleri atıkları ile imha edilme sürecini gösterir. Kurtarmak ve geri dönüşümünü sağlamak için uygun şartlarda saklanması gerekir. EEE Yönetmeliğine Uygundur Ve Elektronik Eşyalarda Bazı Zararlı Maddelerin Kullanımını Sınırladığına Dair Yönetmelik.</p>  <p>Waste Electrical and Electronic Equipment (WEEE) Yönergeleri Avrupa Birliği'nde bu etiket, ürünün ev elektroniği aletleri atıkları ile imha edilme sürecini gösterir. Kurtarmak ve geri dönüşümünü sağlamak için uygun şartlarda saklanması gerekir. EEE Yönetmeliğine Uygundur Ve Elektronik Eşyalarda Bazı Zararlı Maddelerin Kullanımını Sınırladığına Dair Yönetmelik.</p>

Environmental condition for installation

- Since monitor is very sensitive for physical impact, installation requires considerable caution.
- Minimum clearance (20cm) must be secured for smooth ventilation. (See page 6) Installation must avoid air tight or near air tight places. Improper ventilation causes malfunction and shortens product lifetime by rapid internal temperature rise. If monitor has to be installed at the improper ventilation, additional ventilation openings or fans must be provided to keep the internal temperature between 0~ 35 °C.
- For ground of monitor and application devices, it should be connected as frame ground.
- Considering monitor Max power consumption, check the main electric specification.

Recommended Operating Condition

- Temperature: 5~35 °C, Humidity: 35~75%, Suitable operating time : under 18 hours a day.
- Do not install the set at the air-tight condition.
- It is recommended to install the set with good ventilation.
- Do not install the set at the place of direct sunlight or excessive exposure to lightings.
- ❌ Blackening, stains or burning effect on the screen can be occurred by improper installation or use against the above recommended conditions.

Consideration for easier service

- When you design the exterior design for monitor system, consider easier disassembly for possible service occasion in the future.
- If service people can step into the backside of monitor system, it can greatly reduce time and effort for service.
- In case of higher locations, consider the installation location and exterior design for easier service.

❖ Special Notes On LCD Monitors

The following symptoms are normal with LCD monitors and do not indicate a problem.

- When you first turn on the LCD Monitor, the picture may not fit in the display area because of the type of computer that is used. In this case, adjust the picture position to the correct position.
- You may find slightly uneven brightness on the screen depending on the desktop pattern you use.
- Due to the nature of the LCD screen, an afterimage of the previous screen may remain after switching the image, when the same image is displayed for hours. In this case, the screen is recovered slowly by changing the image or turning off the Power Switch for hours.
- Max. non-stop operating time and conditions
 - (1) If a static image is displayed continuously, it is recommended to disrupt it with a motion picture.
 - (2) It is recommended to periodically change the background color and background image.
 - (3) Maximum operating time of the display is 20 hours per day, if the Anti Image Retention is set on. Image Retention is off, do not exceed a 12 hours nonstop operating time limit.
 - (4) If the screen is active for a longer period of time, it is recommended to
 - I. Run the screensaver (motion picture or black pattern)
 - II. Power off the system for a while
 - (5) Make sure that the screen is suitably ventilated, or is used in conjunction with climate control system if installed into any bespoke cabinets.
 - (6) We strongly recommend an active cooling system with fans for long operating times, especially for high luminance LCD models.
- This LCD cannot be used outdoors.
- If you use a cable longer than the supplied one, the picture quality is not guaranteed. Touch function can be disrupted if the USB cable length exceeds 3m.

❖ Customer Service

- If you have to return your unit for service and the original packaging has been discarded, please contact your dealer or service center for advice or replacement packaging.

❖ Cleaning

WARNING

If you drop any materials or liquids such as water into the monitor when cleaning, unplug the power cable immediately and contact your dealer or ODS service center.

CAUTION

For safety reasons, turn off the power switch and unplug the monitor before you clean it.

NOTE

- To protect the LCD panel, do not scratch or rub the screen with a hard object.
- Never use any of the following strong solvents. These will damage the cabinet and the LCD screen.
- Touching the cabinet with any product made from rubber or plastic for a long time may cause degeneration or loss of paint on the cabinet.

Thinner	Benzine	Abrasive cleaner
Spray-type cleaner	Wax	Acid or Alkaline solvent

CABINET : Stains can be removed with a cloth lightly moistened with a mild detergent solvent. Then wipe the cabinet with a soft dry cloth.

LCD : Periodic cleaning with a soft dry cloth is recommended.

SCREEN : Don't use tissue paper etc. because these will damage the LCD screen.

❖ Ergonomic Recommendations

- To eliminate eye fatigue, do not operate the monitor against a bright background or in a dark room. For optimal viewing comfort, the monitor should be just below eye level and 40-60cm (16-24inches) away from your eyes. When using the monitor over a prolonged time, a ten minute break every hour is recommended as looking at the screen continuously can cause eye strain.

1. Safety Precautions



WARNING

■ STOP OPERATING THE MONITOR WHEN YOU SENSE TROUBLE

- If you notice any abnormal phenomena such as smoke, strange sounds or fumes, unplug the monitor and contact your dealer or ODS service center immediately. Further use may be dangerous and can cause fire or electric shock.

■ NEVER REMOVE THE CABINET

- High voltage circuits are inside the monitor. Removing the cabinet may expose you to the danger of fire or electric shock.

■ DO NOT PUT ANY OBJECT INTO THE MONITOR

- Do not put any solid objects or liquids such as water into the monitor. In case of an accident, unplug your monitor immediately and contact your dealer or ODS service center. Using the monitor with any object inside may cause fire, electric shock or damage.

■ INSTALL THE MONITOR ON A FLAT, STABLE SURFACE

- The monitor may cause an injury if it falls or is dropped.

■ DO NOT USE THE MONITOR NEAR WATER

- Do not use where water may be splashed or spilt onto the monitor as it may cause fire or electric shock.

■ OPERATE UNDER THE SPECIFIED POWER SUPPLY

- Be sure to operate the monitor only with the specified power supply. Use of an incorrect voltage will cause malfunction and may cause fire or electric shock.

■ PROTECT THE CABLES

- Do not pull or bend the power cable and signal cable. Do not place the monitor or any other heavy objects on the cables. If damaged, the cables may cause fire or electric shock.

■ ADVERSE WEATHER CONDITIONS

- It is advisable not to operate the monitor during a heavy thunder storm as the continual breaks in power may cause malfunction. It is also advised not to touch the plug in these circumstances as it may cause electric shock.



CAUTION

■ INSTALLATION LOCATION

- Do not install the monitor where sudden temperature changes may occur, or in humid, dusty or smoky areas as it may cause fire, electric shock or damage. You should also avoid areas where the sun shines directly on the monitor.

■ DO NOT PLACE THE MONITOR IN A HAZARDOUS POSITION

- The monitor may topple and cause injury if not suitably located. Please also ensure that you do not place any heavy objects on the monitor, and that all cables are routed such that children may not pull the cables and possibly cause injury.

■ MAINTAIN GOOD VENTILATION

- Ventilation slots are provided to keep the monitor from overheating. Covering the slots may cause fire. To allow adequate air circulation, place the monitor at least 10 cm (or 4 inches) from any walls.
- Do not remove the tilt stand when operating the monitor. Ventilation slots on the back of the cabinet will be blocked and the monitor may overheat if the stand is removed. This may cause fire or damage. Operating the monitor on its back, side, upside down or on a carpet or any other soft material may also cause damage.

■ DISCONNECT THE CABLES WHEN YOU MOVE THE MONITOR

- When you move the monitor, turn off the power switch, unplug the monitor and be sure the signal cable is disconnected. If you do not disconnect them, it may cause fire or electric shock.

■ UNPLUG THE MONITOR

- If the monitor is not in use for a long period of time it is recommended that it is left unplugged to avoid accidents.

■ HOLD THE PLUG WHEN DISCONNECTING

- To disconnect the power cable or signal cable, always pull it by the plug. Never pull on the cable itself as this may cause fire or electric shock.

■ DO NOT TOUCH THE PLUG WITH WET HANDS

- Pulling or inserting the plug with wet hands may cause electric shock.

■ WHEN YOU INSTALL THE MONITOR ON YOUR COMPUTER

- Be sure the computer is strong enough to hold the weight of the monitor, otherwise, you may damage your computer.

■ REMARK FOR 24/7 USAGE

- This product is not specifically designed for 24/7 usage in all environments.

2. Unpacking

- 1) Before unpacking your monitor, prepare a stable, level, and clean surface near a wall outlet.
Set the LCD Monitor box in an upright position and open from the top of the box before removing the top cushions.
- 2) Remove the cart on holders.
- 3) Remove the top cushion and take the accessories box and the Monitor out.

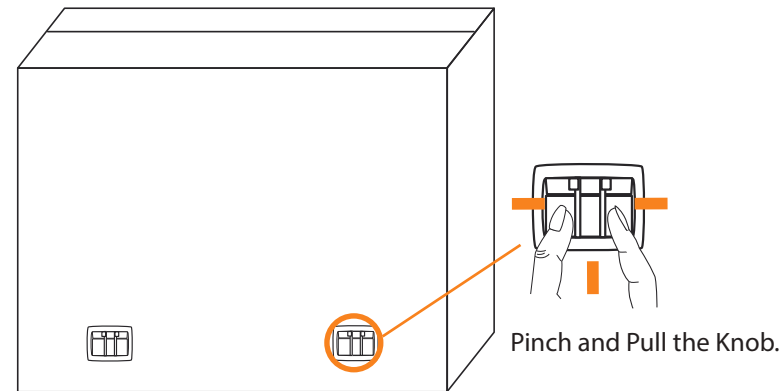

CAUTION

- Moving the monitor requires at least two people. If not, it may drop and could result in a serious injury.
- When moving/shipping the monitor, please hold by the carton holders.

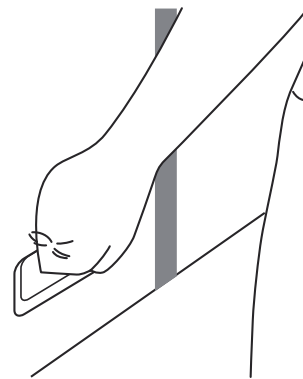

CAUTION

- Permanent damage can occur if Sharp Edged, Pointed or Metal items are used to activate Touch.
- This could invalidate any remaining warranty.
- We recommend you use a plastic stylus (tip R0.8 or over) or finger.

3. Installation

- Follow the manual instructions for the type of mount you have selected. Refer all servicing to qualified service personnel.
- Moving the monitor requires at least two people.
- Before installing, please make sure the wall is strong enough to hold the necessary weight of the display and the mount.

3.1. WALL MOUNTING

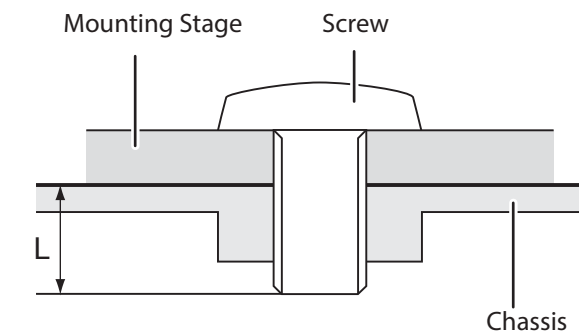

CAUTION

- When using the wall mounting, consideration of thickness of the mounting stage needs to be taken.
- Tighten the M6 Screw with washer which "L" length is 10mm to fasten the monitor. Using a screw longer than this may cause electric shock or damage because it may contact with the electrical parts inside the monitor.

3.2. FAN

CAUTION

- If the screen is used in face-up position, please be sure to turn on the FAN function.
- If you do not use the FAN, the internal temperature rises and the product life cycle may get shorter.
- If the screen is built into an external cabinet, please be sure to implement a cooling unit inside of the cabinet.
- Dirt and dust may stick to the FAN, reducing the cooling effect which may result in a shorter life cycle of the product. Please clean regularly.

3.3. ROTATING THE DISPLAY

- It is designed to be compatible in both landscape and portrait modes.

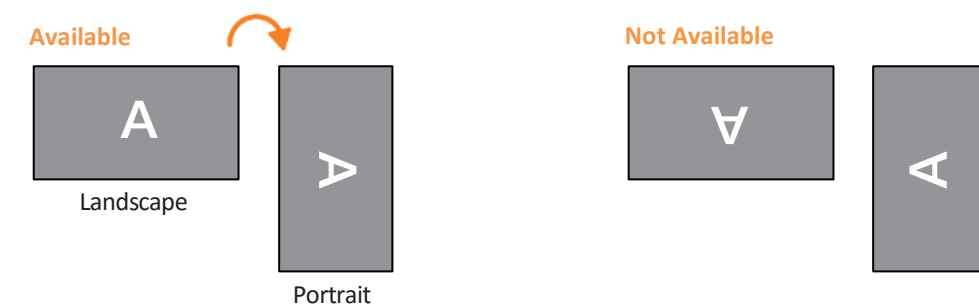

4. Names

▶ Front

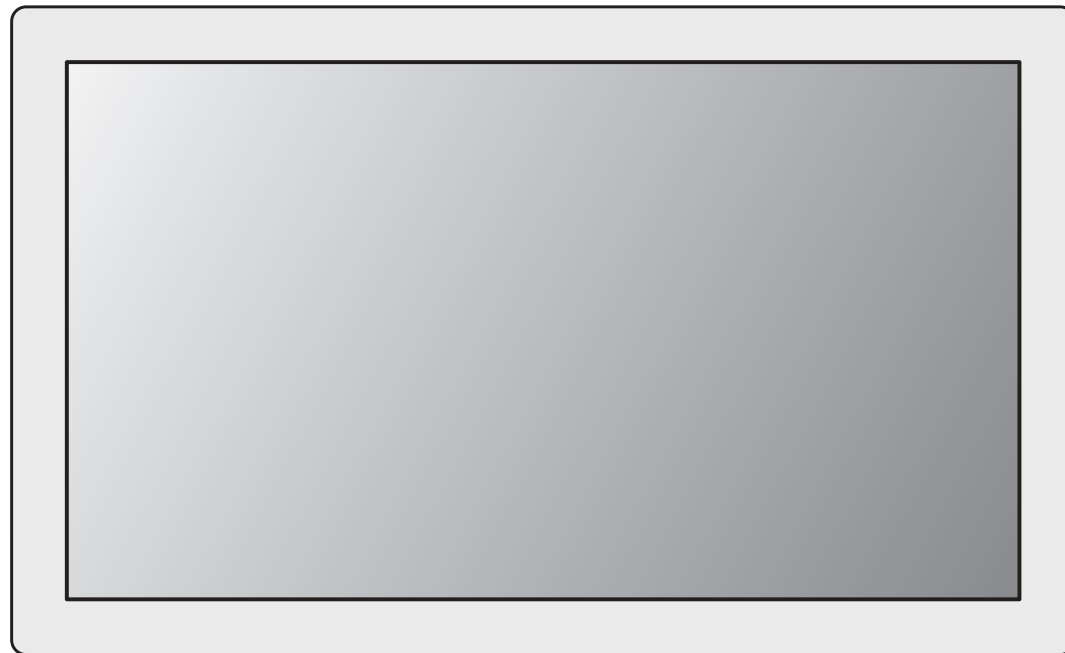

▶ Rear

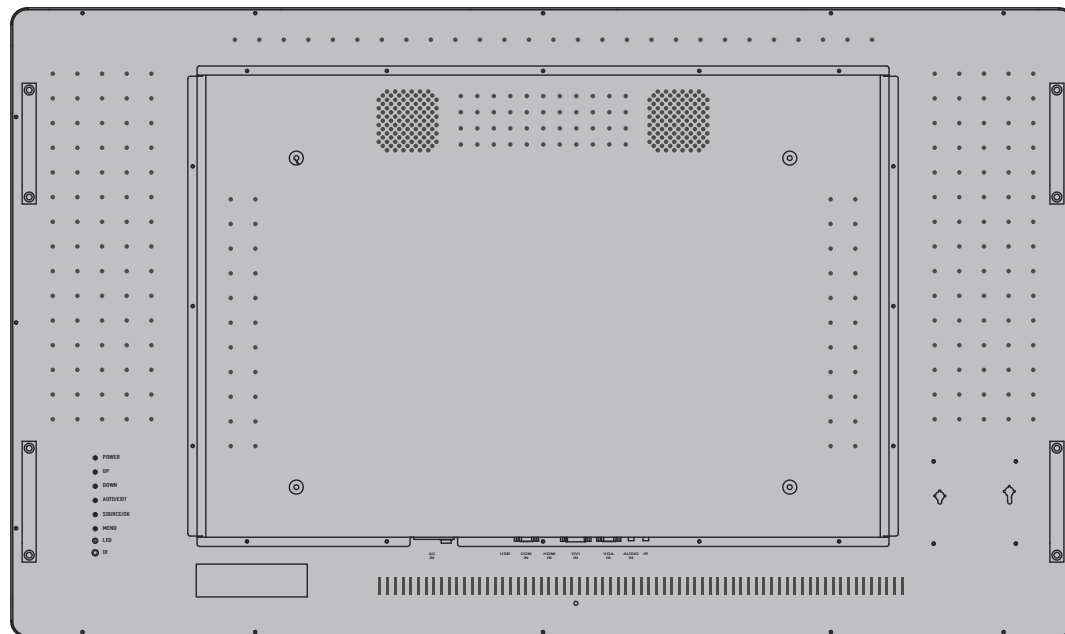

▶ Input Ports

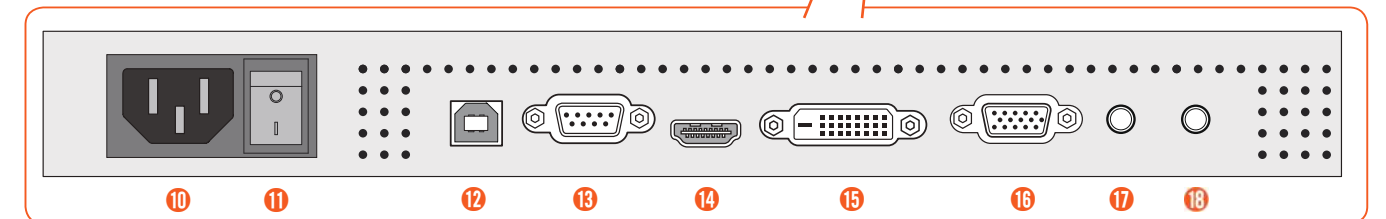
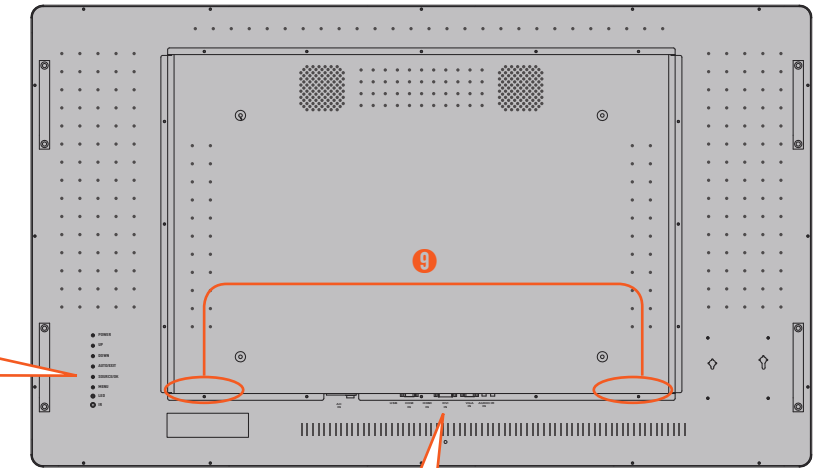
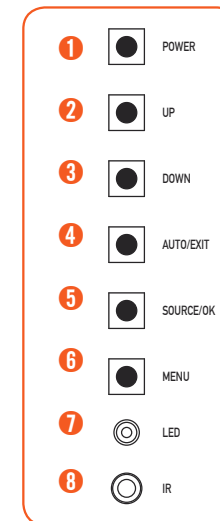

- 1 POWER** Power Button
- 2 UP** Up/Volume + Button
- 3 DOWN** Down/Volume - Button
- 4 AUTO / EXIT** Auto/Exit Button
- 5 SOURCE / OK** Input Select/OK Button
- 6 MENU** Menu Button
- 7 LED** Green : Normal Operation Orange : Power Management
- 8 IR** Remote Sensor
- 9 SPEAKERS** Speakers

- 10 AC IN** AC-INLET : AC Connector(~ : Alternating current) (AC-IN)
- 11 AC SWITCH (- ON) / °OFF** MAIN POWER : Main Power Switch
- 12 USB** Touch USB Connector
- 13 COM IN** D-SUB 9pin, RS232C Connector
- 14 HDMI IN** HDMI Connector
- 15 DVI IN** DVI-D 24pin Connector
- 16 VGA IN** VGA(D-sub) mini 15pin Connector
- 17 AUDIO IN** PC Audio In, Mini Jack, Audio Connector
- 18 IR** Mini Jack, IR Extender Connector

5. Remote Control

- To use remote control we advise you to position it at the back of the monitor (left side) where the remote sensor is located. It might not work if you use it standing in front of the monitor.

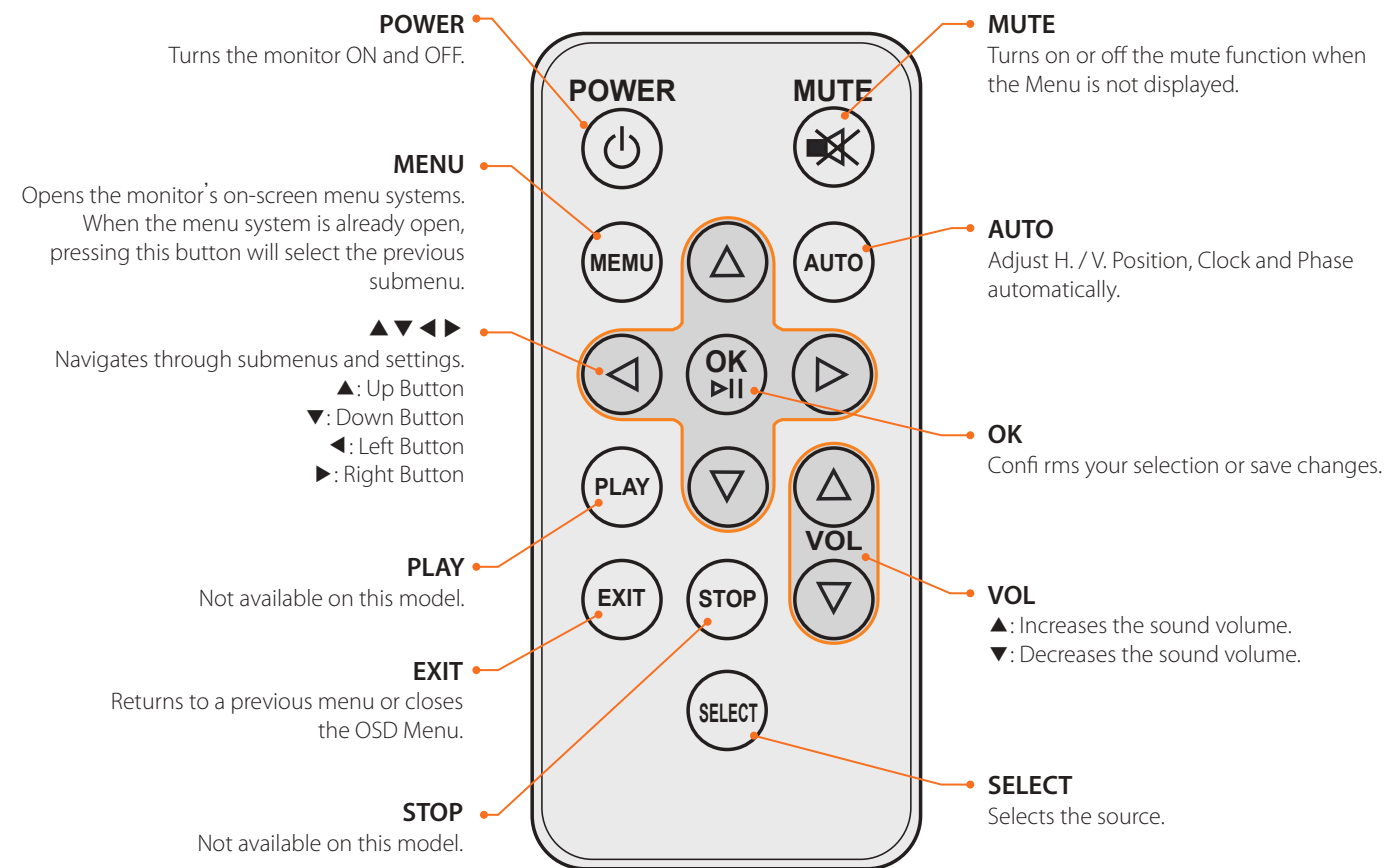

5.1. PREPARING THE REMOTE CONTROL

- To use the remote control, insert the button battery.

CAUTION

- Do not use any other batteries other than those specified in this manual for the Remote Control.
- Burst batteries or the electrolyte from these batteries may cause stains, fire or injury.

- 1) Push Lock to right and remove the battery case in the direction of the arrow.
- 2) Put it in face up the + side of the button battery (CR2032).
- 3) Replace the battery case in the direction of the arrow.

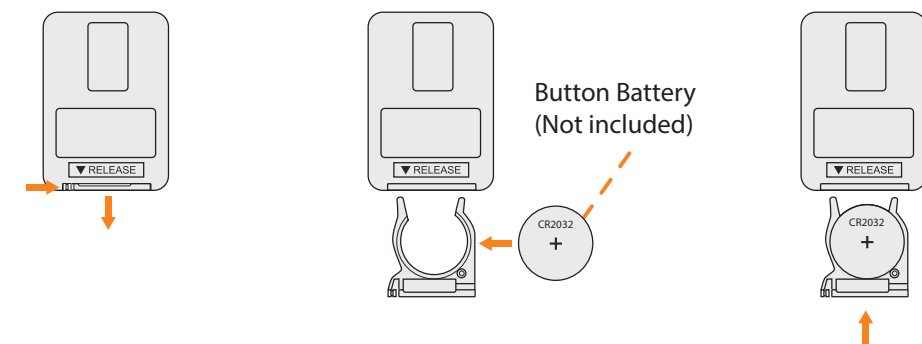

NOTE

- Replace with new batteries when the Remote Control does not work close to the monitor. Use the button battery (CR2032).
- Operate the Remote Control by pointing it toward the Remote Sensor on the monitor.
- Other manufacturers remote control will not work with this monitor. Use the provided Remote Control ONLY.
- Used batteries needed to follow the local rules to be discarded. (Suggestion : to dispose of used batteries please follow correct policy as per your local regulations.)

5.2. BASIC OPERATION

■ Turning the monitor ON

- The monitor is on and the Power Indicator turns Green when you press the Power Button on the monitor or the Remote Control. The monitor is off and the Power Indicator turns Orange when you press the Power Button on the monitor or the Remote Control. Press again to turn the monitor on.

NOTE

- Even when using the power management mode or turning OFF the Power Switch, the monitor will consume a small amount of electricity. Disconnect the Power Cable from the power supply whenever the monitor is not in use or during the night, to avoid unnecessary power consumption.

■ Turning the monitor ON

- The menu page appears on the screen when you press the MENU Button on the monitor or the Remote Control.
- The menu page disappears when you press the EXIT Button on the Monitor or the Remote Control.

■ Turning the monitor ON

- Select adjustment by pressing the UP / DOWN Button on the monitor or the ▲ / ▼ Button on the Remote Control while the menu page is displayed on the screen.

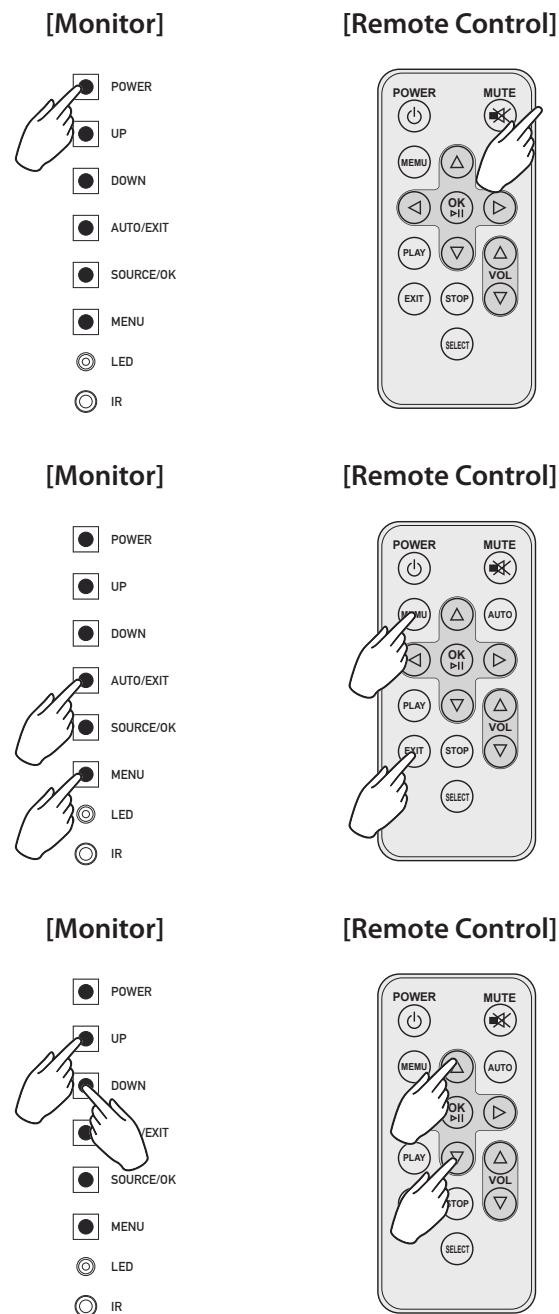

■ Move the cursor horizontally

- Select menu or setting, or perform the adjustment by pressing the ◀ / ▶ Button on the Remote Control while the menu page is displayed on the screen.

■ Adjust the volume of sound

- Press the UP / DOWN Button on the Monitor or the VOL ▲ / ▼ Button on the Remote Control to adjust the volume of sound when the menu page is not displayed on the screen.

■ Switch the input signal

- This is activated when you successively press the SOURCE Button on the monitor or SELECT Button on the Remote Control.

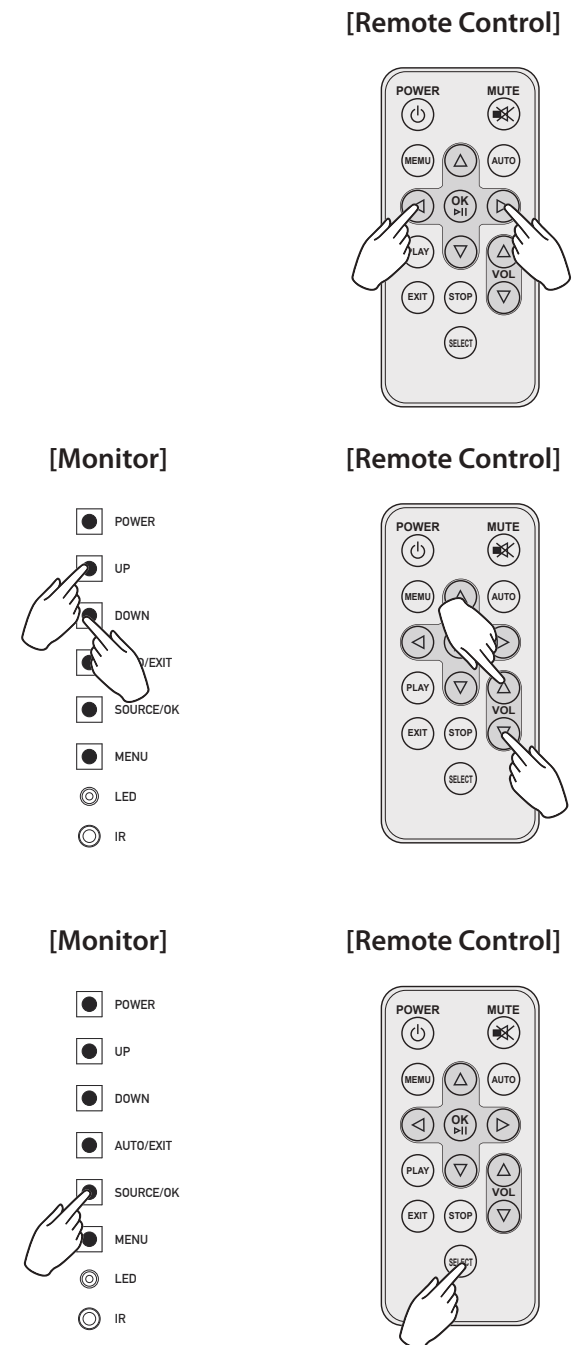

6. How to Connect Cables

- Ensure that both the computer and the monitor are switched off.
- Connect the computer to the monitor with the signal cable.
- Connect the computer to the monitor with the USB cable.
- Connect the Power Cable to the monitor first and then to the power supply.
- Turn on your monitor (Main Power Switch and Power Switch) and computer.

NOTE

- The signal cables used for connecting the computer and monitor may vary with the type of computer used. An incorrect connection may cause serious damage to both the monitor and the computer. The cable supplied with the monitor is for a standard connector. If a special cable is required please contact your local dealer or regional office.
- For connection to Macintosh computers, contact your local dealer or regional office for a suitable adaptor.
- Make sure you tighten the finger screws at each end of the Signal Cable.
- Don't connect the RS-232C cable and the USB cable to the computer at the same time. And cannot use those at the same time.
- When USB cable connected than wait for 8 seconds and the touch function is ready to go. It can be activated by pen, finger or any other pointer.

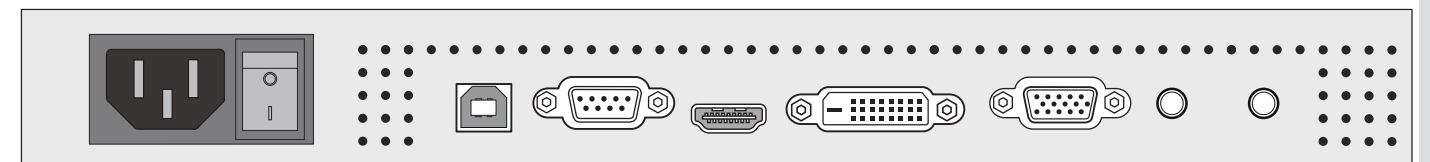
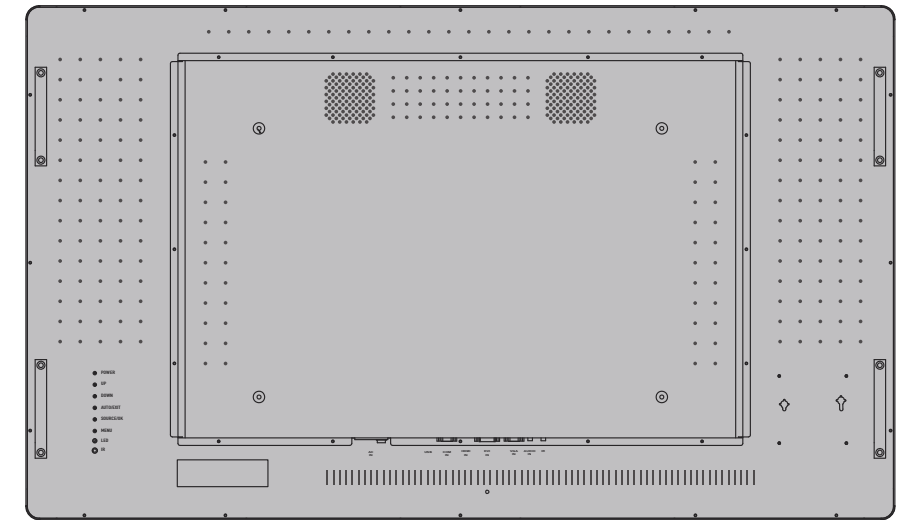
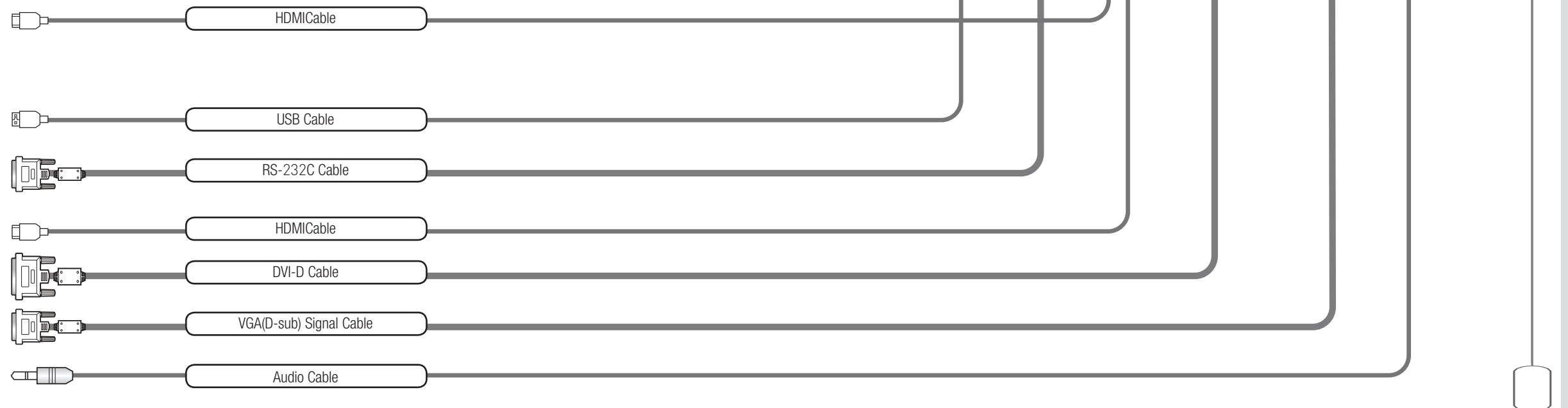
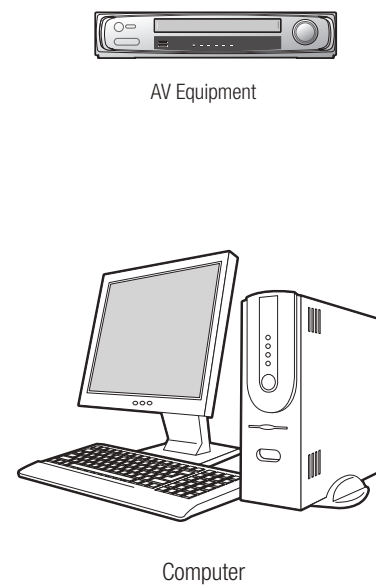

AC IN USB COM IN HDMI IN DVI IN VGA IN AUDIO IN IR

7. Computer Setting

■ Signal Timing

· Change to the desired signal timing listed on page 32: COMPLIANT TIMING.

■ Windows XP/Vista/7/8/10 Plug & Play

· The LCD monitor complies with DDC2B of VESA standard. The Plug & Play function runs on Windows XP/Vista/7/8 by connecting the monitor to DDC2B compliant computer with the Signal Cable supplied.

NOTE

- For additional information on how to download the driver for your touch screen monitor, please access the internet site noted above.
- Monitor Drivers are not required in most cases for Macintosh or Unix operating systems. For further information, please contact your computer dealer first for advice.

■ Procedure for turning ON the Power Switch

· Turn ON the monitor first, and then the computer.

■ MULTI-TOUCH

- This monitor complies with DDC2B of VESA standard. (Plug & Play compliant)
- The MULTI-TOUCH function runs on Windows 7/8/10 by connecting the monitor to DDC2B compliant
- Computer with the USB cable supplied.

■ MULTI-TOUCH support operation system

- Microsoft Windows Vista (64bit and 32bit)
- Microsoft Windows 7 (64bit and 32bit)
- Microsoft Windows 8 (64bit and 32bit)
- Microsoft Windows 10 (64bit and 32bit)
- Mac OS X V10.4 & above
- Linux (2.6x) & above
- Not support Windows 2000 and earlier versions.

	Windows 10	Windows 8	Windows 7 *5	Windows 7 *4	Vista	XP	Mac OS X	Linux
Default Mouse *1	O	O	O	O	O	O	O	O
Touch Digitizer *2	O	O	O	O	O	X	X	X
Windows 7 Gestures *3	O	O	O	X	X	X	X	X

*1. Default mouse (click, drag, double-click and right-click)

*2. Touch digitizer (click, drag / selection, double-click, right-click, click and visual feedback)

*3. Digitizer with Windows 7 multi-touch gestures

*4. Windows 7 - Starter and Home Basic version

*5. Windows 7 - Home Premium, Professional, Enterprise and Ultimate versions

8. Operating The Monitor

- To create the best picture, your LCD Monitor has been preset at the factory with the COMPLIANT.
- TIMING shown on page 33. You are also able to adjust the picture by following the button operation shown below. For more detailed adjustments, see page 23 for SCREEN ADJUSTMENTS.

1. Press the MENU Button to start the On Screen Display feature. There are additional Menu items which can be switched by using the ▲ / ▼ Buttons.



2. Select the Menu item of the adjustment you want to make. Press the ► or OK Buttons and enter the menu page. Then, use the ▲ / ▼ Buttons to highlight the desired adjustment item.
3. Press the ► or OK Buttons again. Use the ▲ / ▼ Buttons to make the appropriate adjustment or setting.
4. Press the EXIT Button to leave the menu, and the settings you just made would be automatically saved.

- For example, to correct for vertical position, select Menu item of "Display Settings". Select "V".
- Position "b" by using the ▲ / ▼ Buttons. Press the ► or OK Buttons.
- Use the ▲ / ▼ Buttons to change the vertical position settings. The vertical position of the overall display should be changing accordingly while you are doing this.

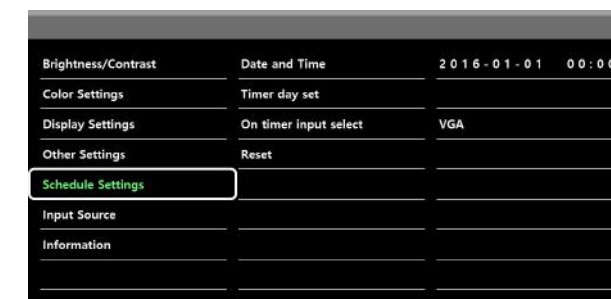

- Press the EXIT Button lastly, it ends, all changes are saved in the memory.

NOTE

- When button operations are aborted during adjustment, On-Screen Display disappears when the time set for the OSD Timeout has passed.
- The MENU / EXIT Button can be used to return previous menu item.
- Any changes are automatically saved in the memory when the On Screen Display disappears. Turning off the power should be avoided while using the Menu.
- Adjustments for Image H./V. Position, Clock and Phase are saved for each signal timing. Except for these adjustments, all other adjustments have only one setting which applies to all signal timings.

9. Adjustment Menu Contents

9.1. Brightness / Contrast



Adjustment Item	Problem / Option	Button to Press
Brightness*	Too dark	▲
	Too bright	▼
Contrast	Too dull	▲
	Too intense	▼

* Adjust the Brightness when you are using the monitor in a dark room and feel the screen is too bright.

9.2. Color Settings

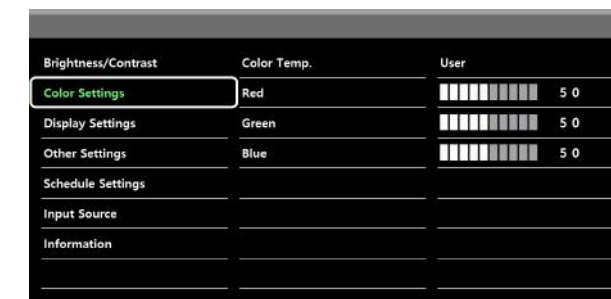

Adjustment Item	Problem / Option	Button to Press
Color Temp.	10000K	More bluish white
	9300K	Bluish white
	6500K	Reddish white
	USER	RED GREEN BLUE

■ LOCK MODE : *Available for Back Controller only.

- Pressing and holding the MENU button and the Power Switch for about 3 seconds when the Menu is not displayed.
 - The OSD menu is not displayed when the OSD is locked. Pressing and holding the MENU button and the Power Switch for about 3 seconds when the Menu is not displayed.
- The following OSD menu is displayed.

Adjustment Item	Problem / Option	
OSD	On	The OSD menu is Locked.
	Off	The OSD menu is Unlocked.
Power Key	On	The POWER SWITCH is Locked.
	Off	The POWER SWITCH is Unlocked.
Remote Control	On	The Remote Control is Locked.
	Off	The Remote Control is Unlocked.

■ PALM REJECTION FUNCTION :

- Palm rejection is a way to disregard signal from finger while using the pen mode.
- When you touch the screen with a pen, palm rejection is activated and the screen does not recognize touch made with the finger.
- If the screen is not touched with a pen for 1 second, it will automatically return to the finger mode.

NOTE

- The screen works only with conductive pens with Φ 4-5mm diameter.
- The touch panel does not recognize pens with smaller or large diameter.
- Touch made by a pen is not recognized within 15mm distance from edge of the active display area.

9.3. Display Settings

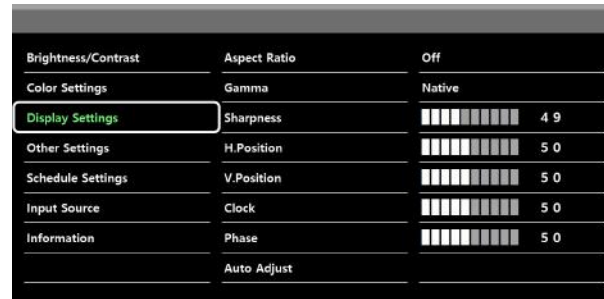

Adjustment Item	Problem / Option		Button to Press
Aspect Ratio	Off	Aspect Ratio is turned off.	
	16 : 10	Displays all picture in 16 : 10 aspect ratio.	
	5 : 4	Displays all picture in 5 : 4 aspect ratio.	
	4 : 3	Displays all picture in 4 : 3 aspect ratio.	
Gamma	You can set the Gamma. Native / 2.2 / 1.8		
Sharpness	You can change the picture quality from 0 to 100 (soft to sharp). Press the ▲ Button to change the picture quality in numerical order. Press the ▼ Button change the picture quality in reverse numerical order.		▲ ▼
H. Position ^{*1}		Too left	▲
		Too right	▼
V. Position ^{*1}		Too low	▲
		Too high	▼
Clock ^{*1,3}		Too narrow	▲
		Too wide	▼
Phase ^{*1,3}	To correct flickering text or lines		▲ ▼
Auto Adjust ^{*1,2}	Adjust H. / V. Position, Clock and Phase automatically.		

9.4. Other Settings

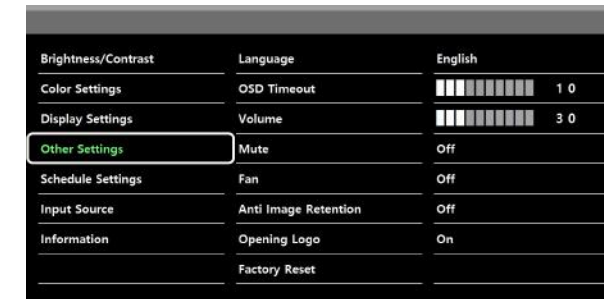

Adjustment Item	Problem / Option		Button to Press	
Language	English	English	Nederlands	Dutch
	Français	French	Poliski	Polish
	Español	Spanish	Русский	Russian
	Deutsch	German	Italiano	Italian
OSD time out	You can set the OSD display duration time. Between 5 and 30 seconds.		▲ ▼	
Volume	Too left		▲	
	Too right		▼	
Mute	On	Turn off the sound temporarily.		
	Off	Return the sound volume to the previous level.		
Fan [*]	On	Fan is turned on.		
	Off	Fan is turned off.		
Anti Image Retention	On	Automatically displays moving patterns (shifting by 2 pixels) to prevent image retention on the screen.		
	Off	Anti Image Retention is turned off.		
Opening Logo	On	ODS Logo displayed when the monitor is turned on.		
	Off	ODS Logo does not display when the monitor is turned on.		
Factory Reset	Factory-preset data is restored.			

* If the screen is used in face-up position, please be sure to turn on the FAN function.

*1. Only Analog input.

*2. For best results, use the Auto Adjust in conjunction with the adjustment pattern. See page 23 for SCREEN ADJUSTMENTS.

*3. See page 23 for SCREEN ADJUSTMENTS.

9.5. Schedule Settings



Adjustment Item	Problem / Option		Button to Press
Date and Time	Date	Adjust the current date and time for the internal clock.	
	Time		
Timer day set*	Sets a recurring schedule. Everyday / Sun / Mon / Tue / Wed / Thu / Fri / Sat		
	Activation	On	Schedule is turned on.
		Off	Schedule is turned off.
	On Time	Set the time for the display to turn on and turn off.	
Off Time			
On timer input select	VGA	Select default input source to use when the display is automatically turned on next time.	
	DVI		
	HDMI		
Reset	On	Schedule Settings will be restored to factory-preset data.	
	Off	Return to Menu.	

* To activate the option, mark it in the setup menu. To deactivate it, remove the marking.

9.6. Input Source

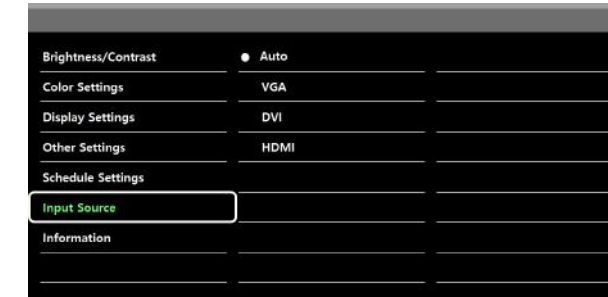

Adjustment Item	Problem / Option		Button to Press
Date and Time	Auto	Select the signal input automatically.	
	VGA	Select the analog input.	
Timer day set	DVI	Select the digital(DVI) input.	
	HDMI	Select the digital(HDMI) input.	

NOTE

- When only one of the three signal inputs is connected to the signal source, the one connected is automatically selected. Input Source functions is not available if there is no signal input from the selected connector or during the power management mode.

9.7. Information

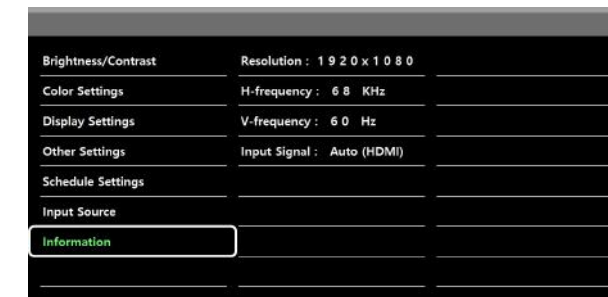

Displays information regarding the current input signal coming from the graphic card in your computer.

NOTE

- See your graphic card user guide for more information about changing the resolution and refresh.

10. Power Management Feature

- The power management feature of this product complies with power saving requirement of VESA DPMS. When activated, it automatically reduces unnecessary power consumption of the monitor when your computer is not in use.
- To use the feature, the monitor needs to be connected to a VESA DPMS compliant computer.
- There is a power management step the monitor takes as described below. The power management function, including any timer settings is configured by the operating system. Check your operating system manual for information on how this can be configured.

■ Power Management Mode

- When the H-sync. signal / V-sync. signal / H and V sync. signals from the computer are off, the monitor enters into Power Management Mode which reduces the power consumption to less than 0.5W. The screen becomes dark. From Power Management Mode, the image reappears in several seconds when either the keyboard or the mouse are touched again.

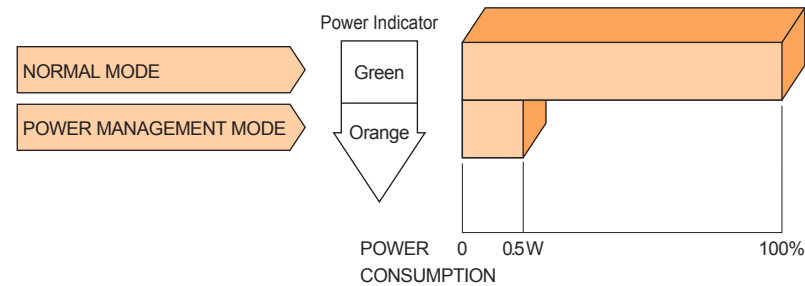

NOTE

- Even when using the power management mode, the monitor consumes electricity. Turn off the Power Switch whenever the monitor is not in use, during the night and weekends, to avoid unnecessary power consumption.
- It is possible that the video signal from the computer may be on while the H or V sync. signal is missing. In this instance, the POWER MANAGEMENT feature may not work properly.

11. Trouble Shooting

- If the monitor fails to operate correctly, please follow the steps below for a possible solution.
 1. Perform the adjustments described in OPERATING THE MONITOR, depending on the problem you have. If the monitor does not get a picture, skip to 2.
 2. Consult the following items if you cannot find an appropriate adjustment item in OPERATING THE MONITOR or if the problem persists.
 3. If you are experiencing a problem which is not described below or you cannot correct the problem, discontinue using the monitor and contact your dealer or service center for further assistance.

Problem		
1	The picture does not appear.	<ul style="list-style-type: none"> · The power Cable is firmly seated in the socket. · The power Switch is turned ON. · The AC socket is live. Please check with another piece of equipment. · If the blank screen saver is in active mode, touch the keyboard or the mouse. · Increase the Contrast and/or Brightness. · The computer is ON. · The signal cable is properly connected. · The signal timing of the computer is within the specification of the monitor. · If the monitor is in power management mode, touch the keyboard or the mouse.
2	The screen is not synchronized.	<ul style="list-style-type: none"> · The signal cable is properly connected. · The signal timing of the computer is within the specification of the monitor. · The video output level of the computer is within the specification of the monitor.
3	The screen position is not in the center.	<ul style="list-style-type: none"> · The signal timing of the computer is within the specification of the monitor.
4	The screen is too bright or too dark.	<ul style="list-style-type: none"> · The video output level of the computer is within the specification of the monitor.
5	The screen is shaking.	<ul style="list-style-type: none"> · The power voltage is within the specification of the monitor. · The signal timing of the computer is within the specification of the monitor.
6	No sound.	<ul style="list-style-type: none"> · The audio equipment(computer etc.) is ON. · The audio cable is properly connected. · The volume is turned up. · The mute is OFF. · The audio output level of the audio equipment is within the specification of the monitor.
7	The sound is too loud or too quiet.	<ul style="list-style-type: none"> · The audio output level of the audio equipment is within the specification of the monitor.
8	A strange noise is heard.	<ul style="list-style-type: none"> · The audio cable is properly connected.
9	The touch screen shows no response.	<ul style="list-style-type: none"> · The USB cable is firmly seated in the socket. · Touch screen driver software is installed.
10	The touch position does not deviate.	<ul style="list-style-type: none"> · The calibration function set up correctly.