

Technical Specifications

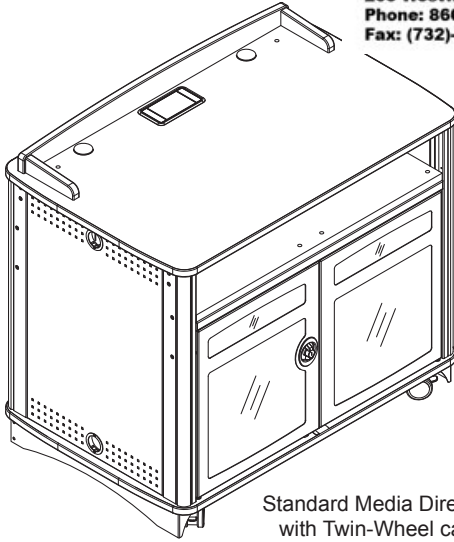

205 Westwood Ave, Long Branch, NJ 07740
Phone: 866-94 BOARDS (26273) / (732)-222-1511
Fax: (732)-222-7088 | E-mail: sales@touchboards.com

55260	Standard Media Director V2
55259	with Overbridge Control Console™



Standard Media Director V2
with Twin-Wheel casters
55260TW

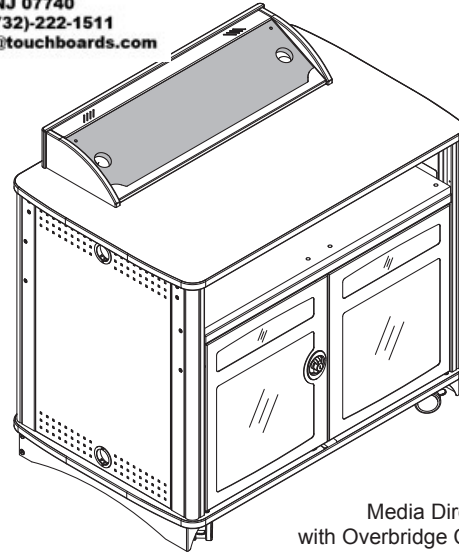

Media Director V2
with Overbridge Control Console
and Twin-Wheel casters
55259TW
shown with optional insert panel (shaded)

Spectrum's Media Director is designed to simplify the use and integration of a multi media lectern. We've designed the Media Director so that integrating podium lecterns couldn't be easier. A total of 52 rack units of rack rail are easily accessible from both front and rear to offer flexibility for the audiovisual setup of your choice. Quick-release doors and coordinated pass-through grommets simplify integration even further. Need to use monitor arms or a power/communication module? The Media Director includes standard cutouts on the worksurface for 2 arms and 1 module that double as grommets when not used. Overbridge models use an overbridge console specifically for the installation of training and presentation controls. Don't limit your integration potential – let the Media Director help you achieve your AV goals.

Base Options
TW - 3" Twin-Wheel casters TK - Toe Kick

Options & Accessories
Page 9

Features and Benefits

- Front and rear rack-rail equipment mounting simplifies installation for any equipment configuration with enough space for an internal CPU
- Standard rack rail brackets allow the front and rear rack rails to be moved further inside the unit, if necessary, to accommodate larger knobs and plugs
- Double-bolt, keyed locking front and rear doors provide security and easy-access
- Blank overbridge console version allows custom cutouts and installation of presentation controllers
- 3" swivel locking Twin-Wheel (TW) casters, and Toe Kick (TK) versions available
- Quick-release door hinges allow doors to be removed for full-access
- Removable acrylic viewing / access panel on the front door provides easy monitoring and access to internal equipment
- Ventilated side panels keep equipment cool
- Audience-side vented openings provide enhanced sound quality when speakers are installed
- Scratch and impact resistant 1 1/8" high-pressure laminate worksurface
- One rectangular worksurface grommet provides cable access or the ability to mount a power / communication module (standard version only)
- Two 2" cable grommets (left and right) on the worksurface or overbridge provide cable access
- Cable grommets throughout the unit keep wires and cords manageable
- Removable acrylic viewing / access panels on the front doors provide easy monitoring and access to internal equipment
- With enough storage space for an internal CPU, left or right-mountable rack-rail simplifies installation for any equipment configuration
- Pre-drilled left and right monitor arm mounting holes allow easy installation of a monitor arm
- Quick-change logo panel simplifies adding or changing logos
- Optional adjustable-height, flip-up shelf provides a convenient additional worksurface
- Optional 15' retractable UL-listed 15-amp power cord reel provides quick and easy power-access
- Optional steel handle provides easy mobility
- Wide variety of options and accessories allow unit to be configured to most situations
- Warranted to be free of all defects in materials and workmanship with a 10-year warranty

Color Options

Standard laminate / color combinations

Wild Cherry / Black
(CHB)



Indigo Organix / Black
(IB)



Indigo Organix / Dark Gray
(ID)



Fusion Maple / Black
(FMB)



Standard color combination refers to the quickest deliverable product color combination. Custom laminates and color combinations are available-additional lead-times and up-charges may apply. Call 1-800-235-1262 for further information.

Construction

- The worksurface, mid, and base panels are constructed from 1/16" thick NAUF (No Added Urea Formaldehyde) composite board with .030 high-pressure laminate on one face, and a balancing phenolic backer on the opposing face
- Metal components consist of 16-gauge and 20-gauge steel
- 16-gauge steel doors and corner columns
- Worksurface edges are covered with 3mm vinyl
- All metal components are finished with a scratch-resistant powder coat epoxy
- Solid wood corner trim
- Each Media Director V2 Lectern is factory-assembled with casters, packaged, and shipped on its own skid

Specifications

Total internal area (mid section)	39 5/8"W x 27 3/4"D x 6 3/8"H
Total internal area (lower section)	39 5/8"W x 27 1/4"D x 24 15/16"H
CPU area	12"W x 25"D
Standard rack rail	52RU (four sets of 13RU)
3" Twin-Wheel casters	weight capacity 165 lbs each
Flip-up shelf	23"W x 27 3/4"D x 1" thick, can support a maximum of 50 lbs. Shelf hinges lock into place in the upright position, Adjustable height
Worksurface grommet	7 1/4"W x 3 7/8"D
Available cutout area in blank overbridge panel	26 1/4"W x 8 3/16"D
Unit weights (nominal)	254 lbs - with casters and surround 274 lbs - with toe kick and surround 235 lbs - with overbridge
Shipping weights (nominal)	334 lbs - with casters and surround 354 lbs - with toe kick and surround 315 lbs - with overbridge
Meets or exceeds applicable ANSI-BIFMA test standards	

Specifications subject to change without notice

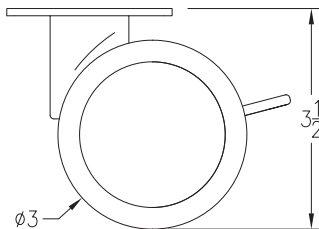

3" Twin-Wheel caster (TW)

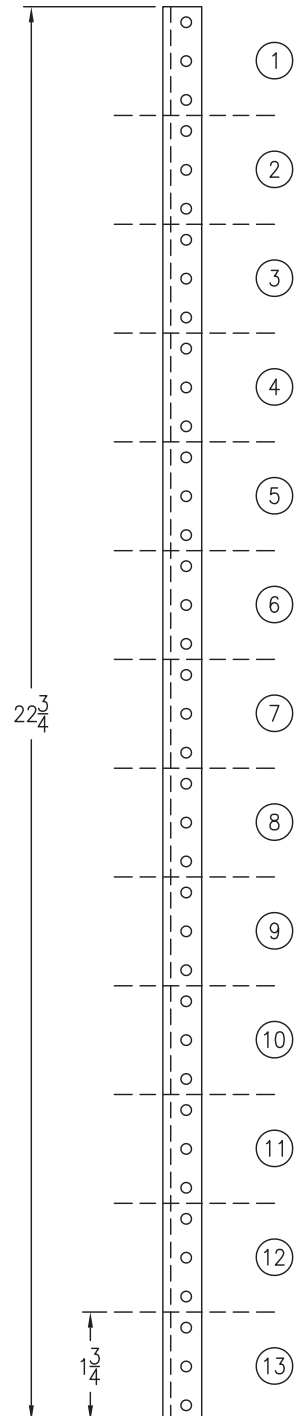
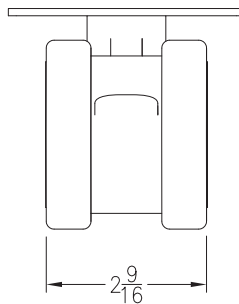

13RU available

Models

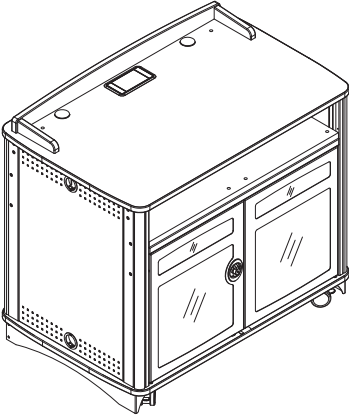
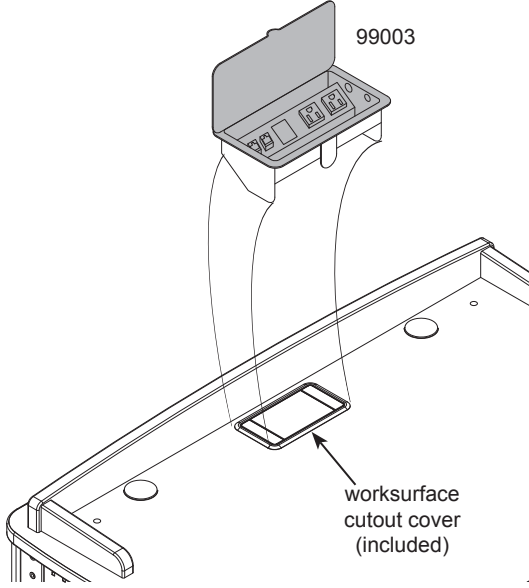
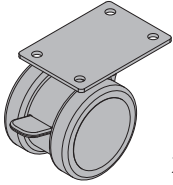
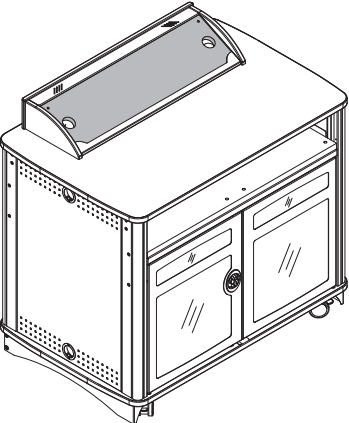
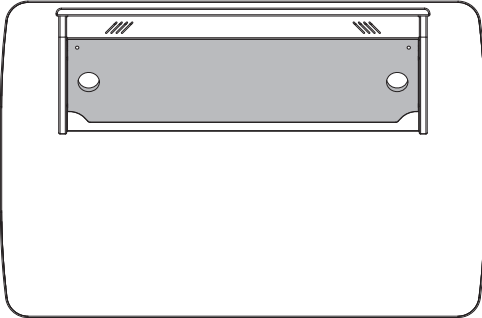
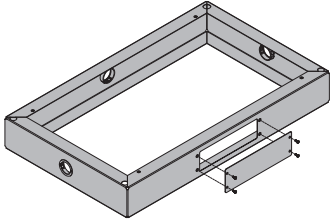
	Worksurface:	Base Options:
<p>Standard MDV2 Lectern</p>  <p style="text-align: right;">55260</p>	<p>99003</p>  <p>worksurface cutout cover (included)</p> <p>Surround with one worksurface cutout and cover for use with optional Power / Communication Modules (not included). Includes two 2" grommet holes with covers for routing cords from worksurface, and two 3/8" holes with plugs for optional monitor arm mounting.</p>	 <p>X 4 (TW) 3" Twin-Wheel casters</p>
<p>MDV2 Lectern with Overbridge Control Console</p>  <p>Note: The insert panel shown (<i>shaded</i>) is <u>not</u> included with the lectern or overbridge. This option needs to be ordered separately to complete the overbridge.</p> <p style="text-align: right;">55259</p>	 <p>Overbridge with blank insert panel for custom cutouts (see p.8 for dimensions). Overbridge is not available separately. Includes two 2" grommet holes with covers.</p>	 <p>(TK) Standard Toe Kick</p>

Media Director V2 with TW casters and surround
 (shown with optional handle, flip-up shelf, pull-
 out drawer, and adjustable keyboard tray)

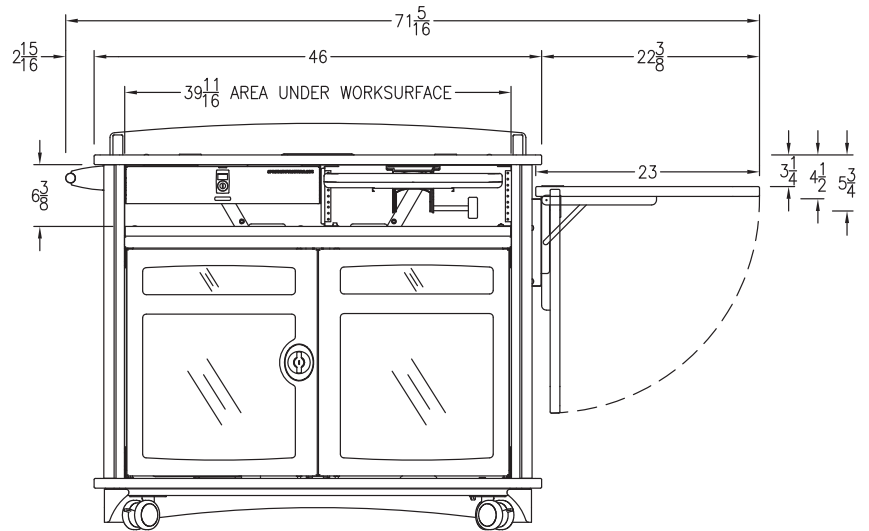
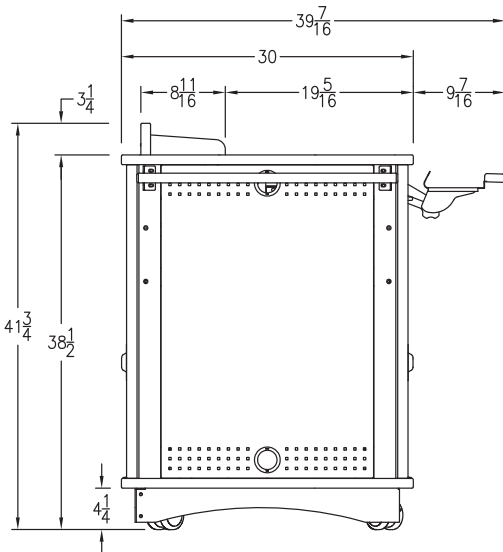
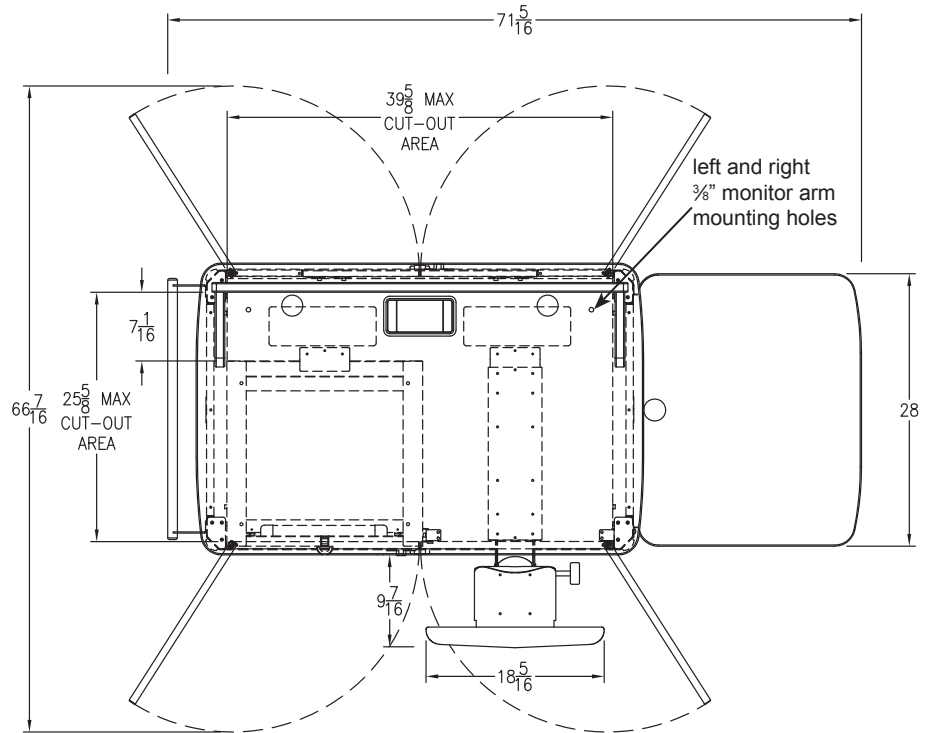
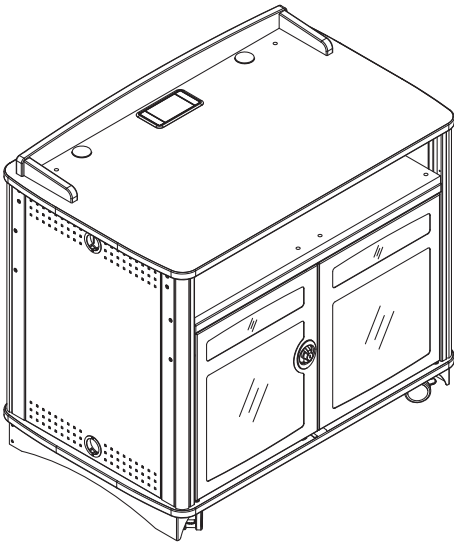

Note: Modified worksurface cutouts should be reviewed by Spectrum to ensure clearance of brackets, keyboard slides, or other objects under the worksurface.

Media Director V2 with Toe Kick and surround
(shown with optional keyboard tray)

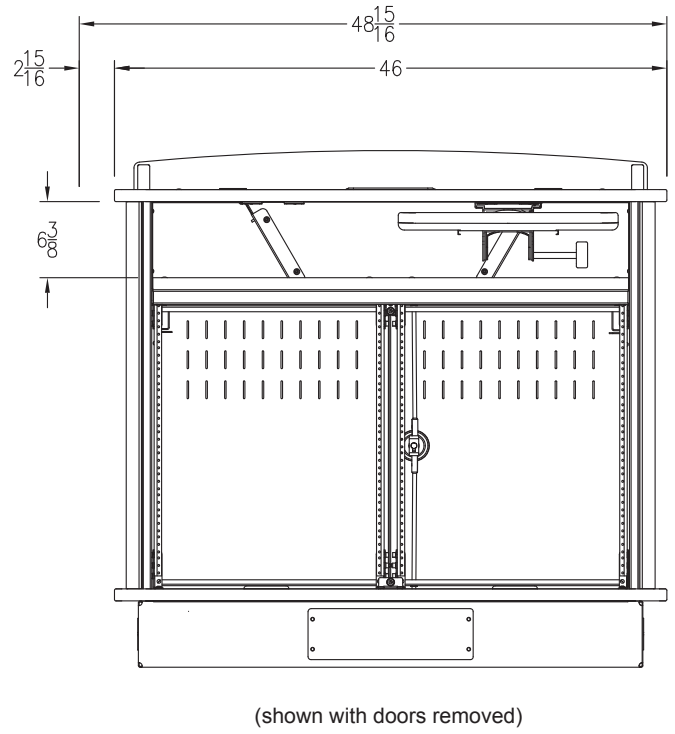
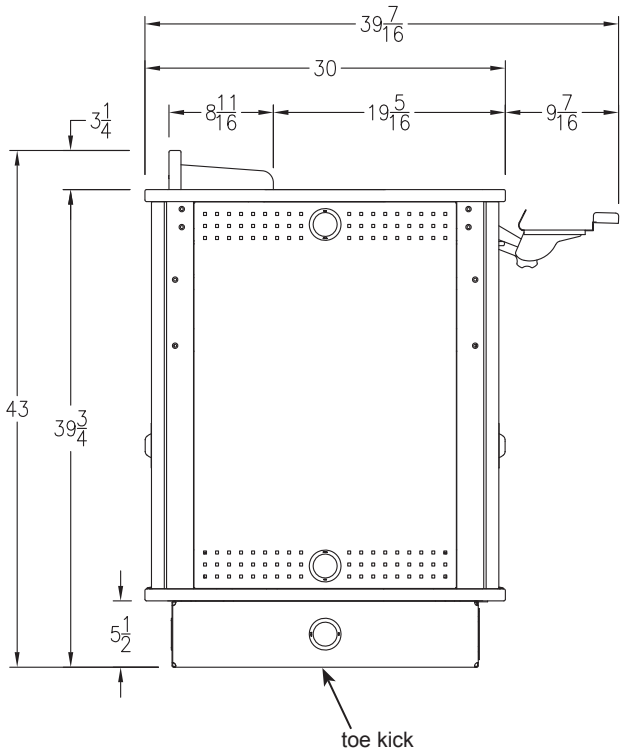

all Media Director Lecterns include
two mid-panel cutouts measuring
11"W x 4"D to rack rail area below

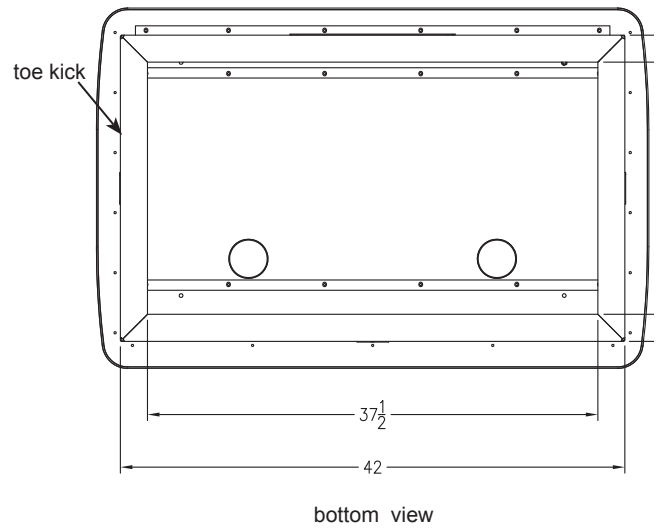
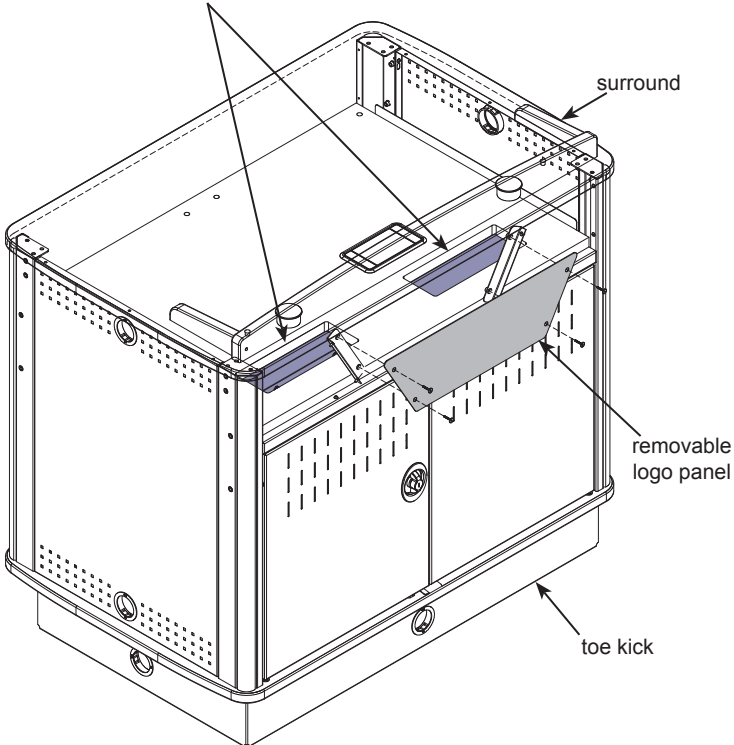

Media Director V2
section view

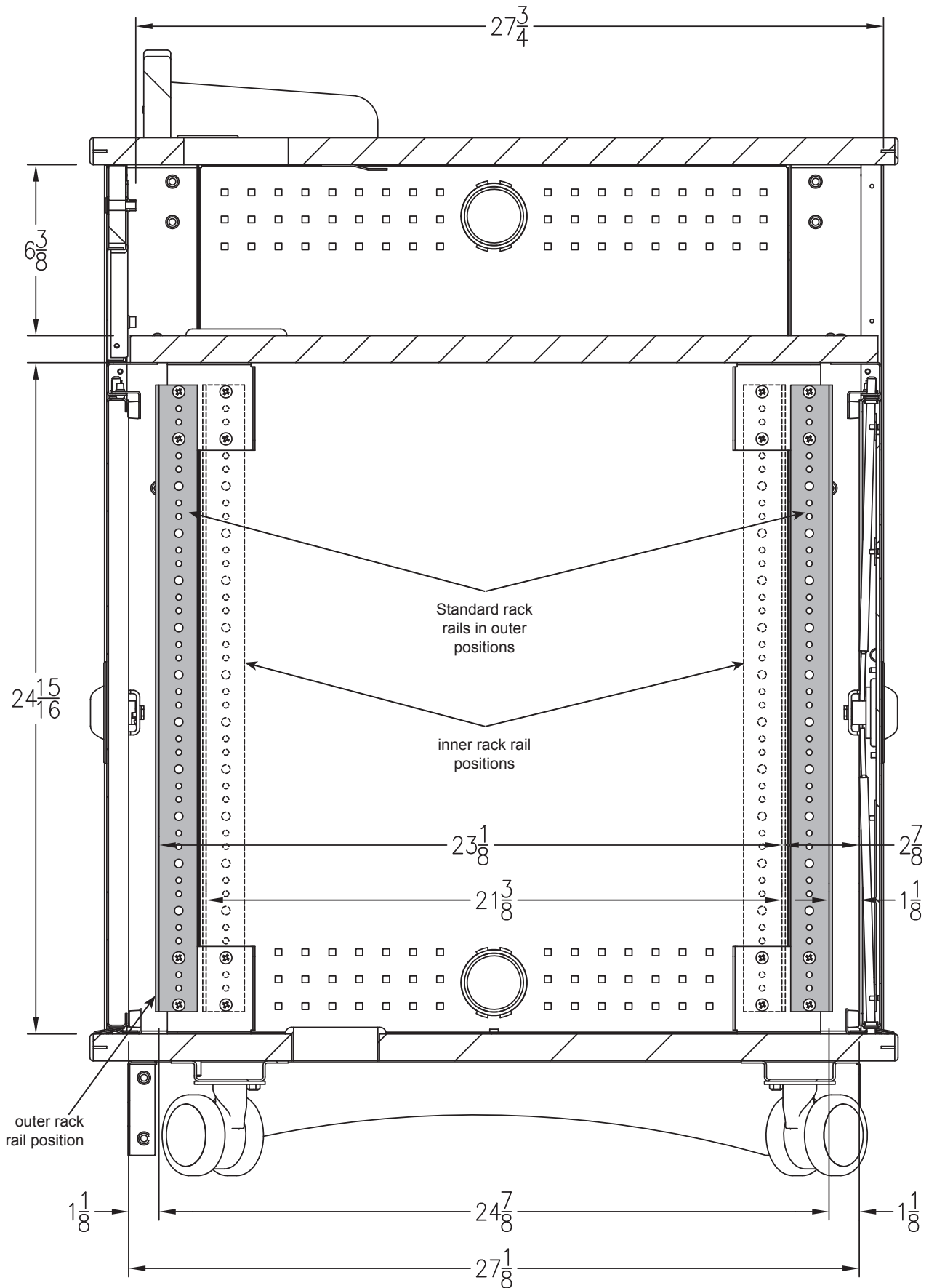

Media Director V2 with Overbridge
Control Console and twin wheels

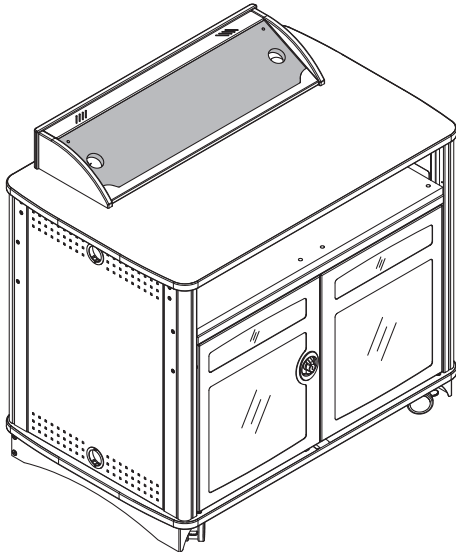

Note: The insert panel shown (*shaded*) is not included with the lectern or overbridge. This option needs to be ordered separately to complete the overbridge.

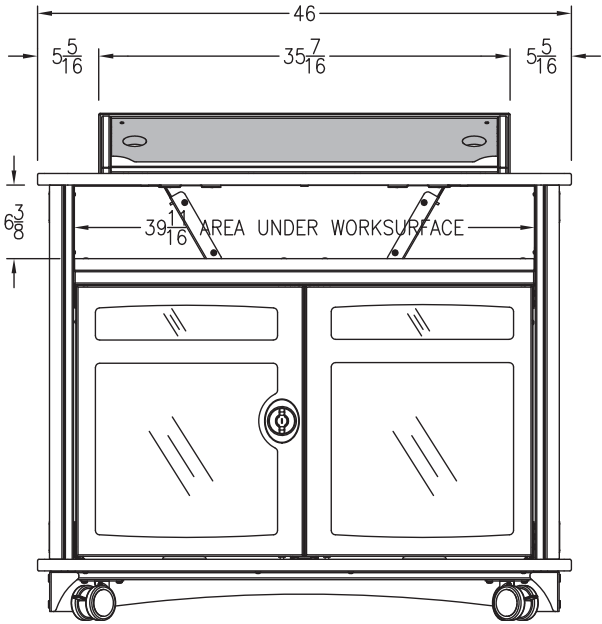
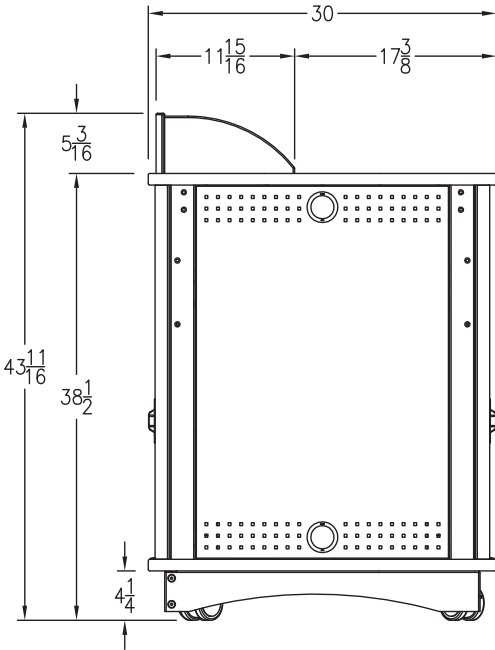
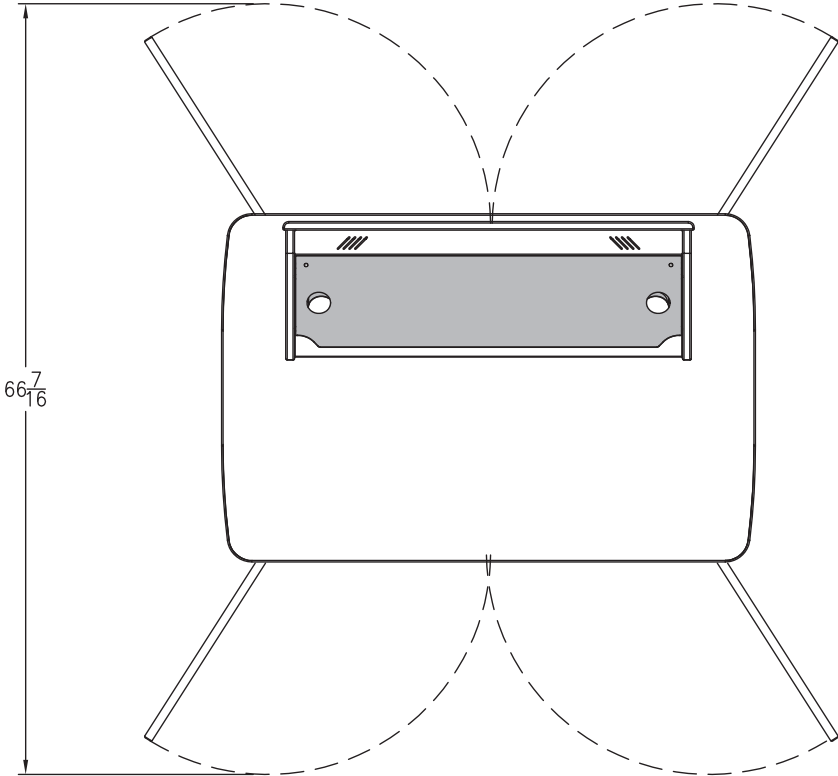

Media Director V2 overbridge panel blank
(flat view)

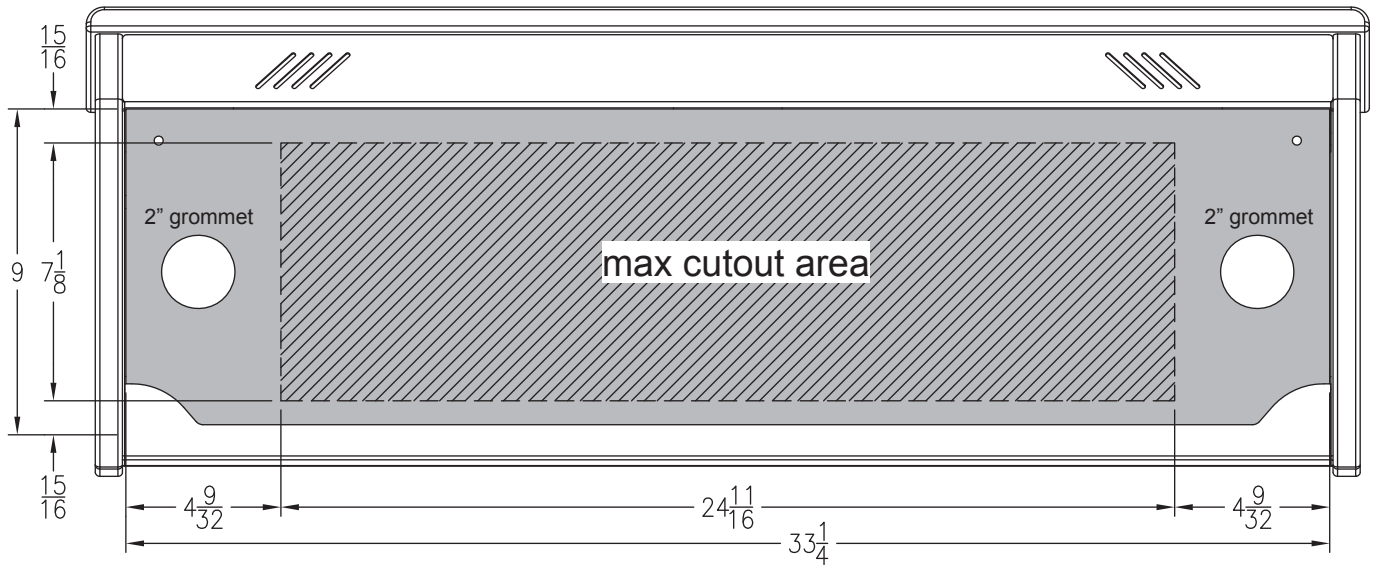

Note: The Overbridge Control Console™ has been designed for many of the currently available controllers on the market, however, modified cutouts should be reviewed by Spectrum to ensure clearance of brackets, keyboard slides, or other objects under the worksurface.

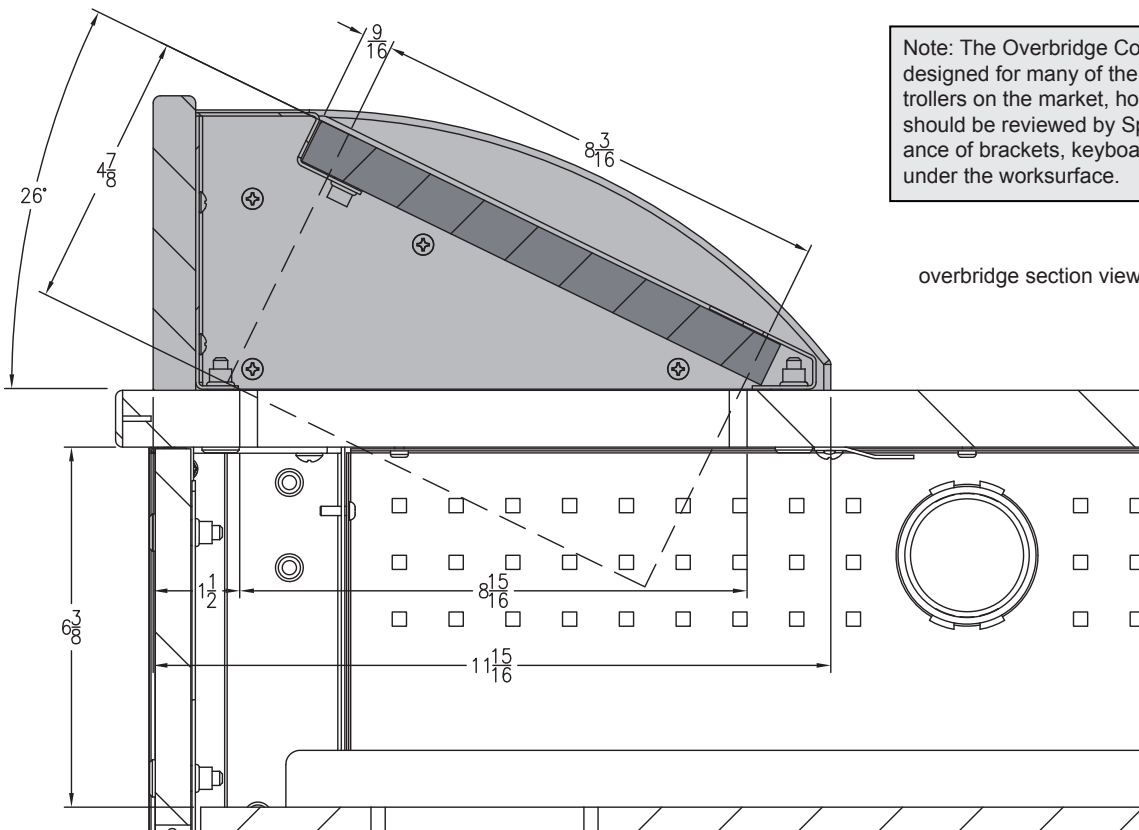

overbridge section view

Note: The insert panel shown (shaded) is not included with the lectern or overbridge. This option needs to be ordered separately to complete the overbridge. This insert panel is horizontally symmetrical and can be easily removed, rotated, and re-installed if a cutout needs to be relocated to the opposite side of the overbridge.

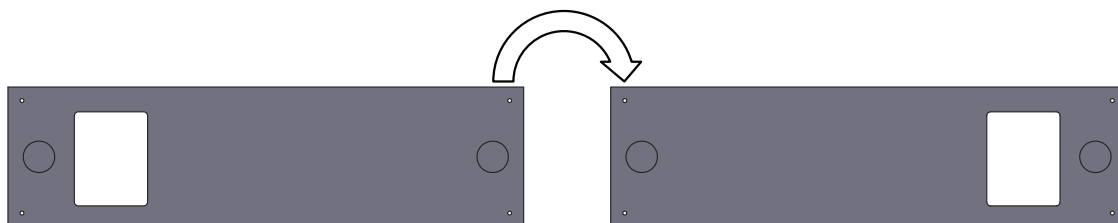

Options

Note: The flip-up shelf and steel handle can be mounted on either side of the lectern. Both can be mounted on the same side, but the shelf needs to be mounted in a lower position to provide enough clearance for the handle.

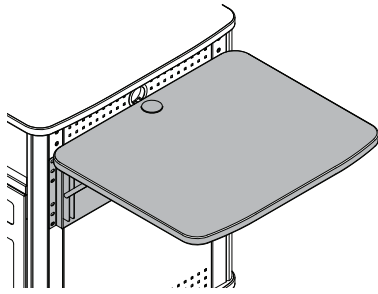

Flip-Up Shelf
 (mounts on left or right side, max two per unit)
 includes 2" grommet
 23"W x 27 $\frac{3}{8}$ "D
 (50 lbs max capacity)
 55263

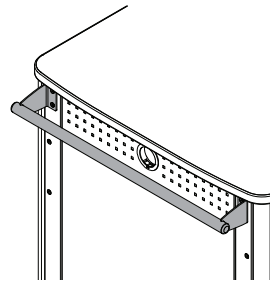

Steel Handle
 (mounts on left or right side, max two per unit)
 55265

Note: Power and communication wiring for document cameras, laptop computers, and/or projectors placed on the flip-up shelf should be routed on top of the audience-side of the shelf. Use of the shelf grommet hole for wiring will result in pinching of the cords when the shelf is folded.

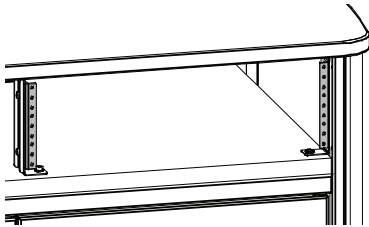

Upper Rack Rail Kit (3RU)
 (max 2 per unit)
 55266

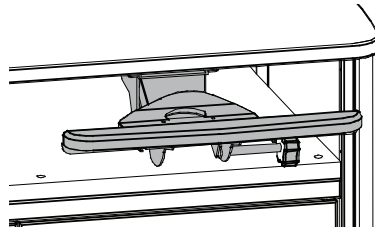

Adjustable Econo Keyboard Tray
 18 $\frac{3}{8}$ "W x 17 $\frac{1}{4}$ "D
 (max 2 per unit)
 95520

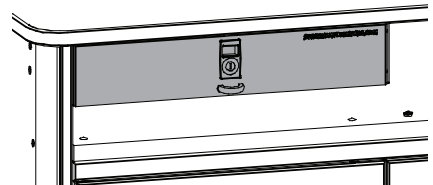

Pull-Out Drawer
 18 $\frac{3}{8}$ "W x 15 $\frac{1}{4}$ "D x 3 $\frac{1}{8}$ "H
 (max 1 per unit)
 55264

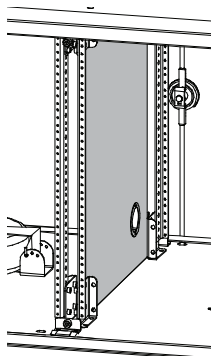

Security Panel
 55262

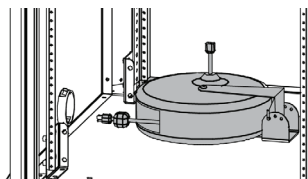

Retractable Cord Reel
 15' retractable, 15-amp, 12 AWG,
 with breaker, UL listed
 99029

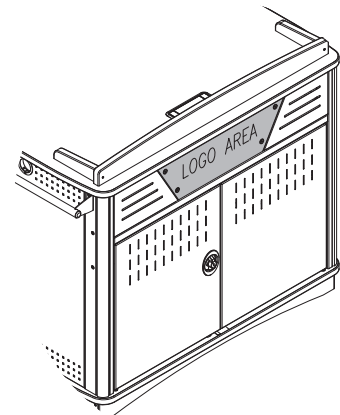

Custom-Cut Logo Panel
 (audience-side)
 55261

Note: When installed, the optional cord reel takes up 3RU from the bottom of the rack rail.

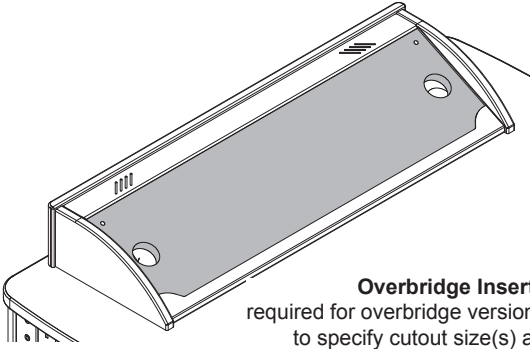

Overbridge Insert Panel
required for overbridge version-contact Spectrum
to specify cutout size(s) and position(s)
overbridge not available separately
96507 - blank panel
96507mod - panel with cutout(s)

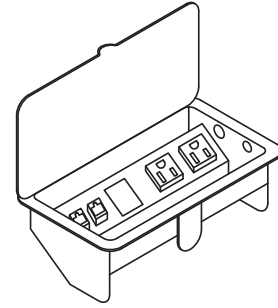

Power/Communication Module
with 9' power cord, two outlets, and two data jacks
7 1/8"W x 3 5/8"D (standard models only)
99003 (without mic jack)

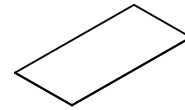

Non-Slip CPU Pad
11"W x 23"D
95518



Flat Panel Monitor Arms & Tablet Mounts
(See the Spectrum website or catalog for the latest available monitor arm & tablet mounting options)

Rack-mount accessories

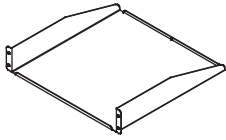

Cantilever Shelf (2RU)
 17½"W x 18"D x 3½"H
 (50 lbs max load)
 97504

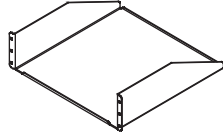

Cantilever Shelf (3RU)
 17½"W x 18"D x 5¼"H
 (80 lbs max load)
 97502

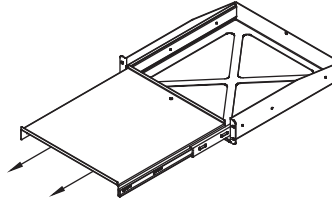

Pull-Out Shelf (2RU)
 16½"W x 17¼"D
 (50 lbs max load)
 97505

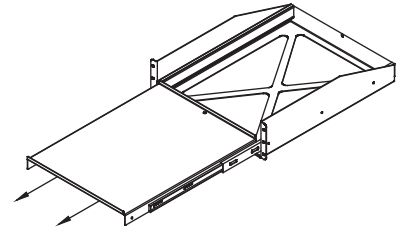

Pull-Out Shelf (3RU)
 16½"W x 21¼"D
 (80 lbs max load)
 97503

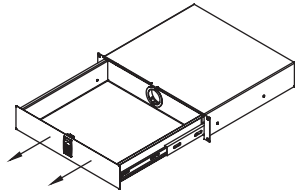

Locking Drawer (2RU)
 interior dims:
 15¾"W x 13¼"D x 2⅞"H
 (25 lbs max load)
 97514

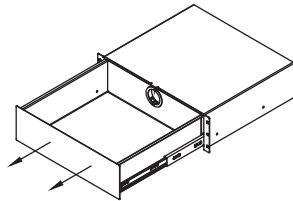

Drawer (3RU)
 interior dims:
 15¹⁵/₁₆"W x 14½"D x 5¼"H
 (50 lbs max load)
 97518

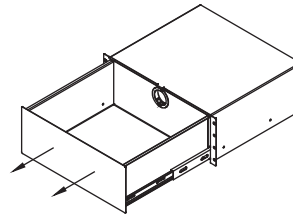

Drawer (4RU)
 interior dims:
 15¹⁵/₁₆"W x 14½"D x 7"H
 (50 lbs max load)
 97519

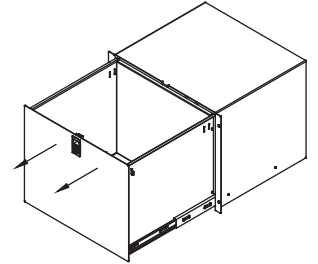

Locking File Drawer (8RU)
 with file holder
 interior dims:
 15¾"W x 13⁹/₁₆"D x 13³/₁₆"H
 (50 lbs max load)
 97515

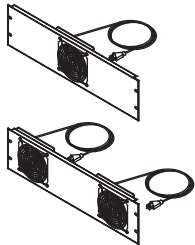

Cooling Fans (3RU)
 19"W x 2"D x 5¼"H
 Single Fan-97507
 Double Fan-97506

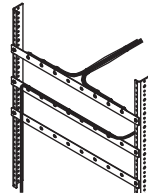

Wire Lace Kit
 3 lace straps included
 95517

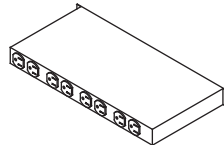

9-Outlet Power Strip (1RU)
 19"W x 9"D x 1¼"H
 99021

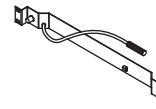

Flexible Halogen Light (1RU)
 19"W x 2"D x 1¼"H
 99033

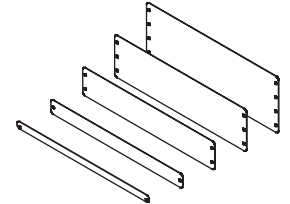

Rack-Mount Blanks
 (fills rack spaces where components are not needed)

- 97516 - (½ RU)
- 97510 - (1RU)
- 97511 - (2RU)
- 97512 - (3RU)
- 97513 - (4RU)

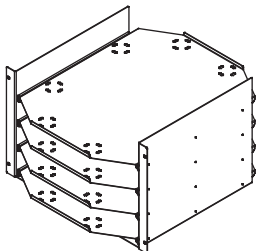

LT-4 Laptop Storage Unit (7RU)
 (stores 4 laptops horizontally)
 laptop tray dims:
 16¼"W x 20½"D x 2⅞"H
 97517

Warranty

WE WILL MAKE IT RIGHT FOR YOU!

Spectrum is committed to provide complete customer satisfaction. Each of our products is manufactured from the best materials available and each product is stringently monitored throughout the production process through our P.A.C.E. program (Product Assurance to meet Customer Expectations).

We expressly warrant that Spectrum products will be of good quality and workmanship and free from defect for the period set out in the warranty table below from the date of delivery. This warranty shall not apply to defects or damage resulting from misuse, abuse, neglect, improper care, modification or repair not authorized by Spectrum, or any other cause outside the control of Spectrum. Spectrum will, at its sole option, either repair or replace the defective product.

This warranty is exclusive; no other warranty, written or oral, is expressed or implied. This warranty is given by Spectrum to Buyer and to no other person or legal entity. No Spectrum dealer, distributor, agent or employee is authorized to make any modification or addition to this warranty.

NOTWITHSTANDING ANYTHING TO THE CONTRARY, SPECTRUM WILL NOT UNDER ANY CIRCUMSTANCES BE LIABLE FOR INDIRECT OR LIQUIDATED DAMAGES, INCLUDING CONSEQUENTIAL, INCIDENTAL AND SPECIAL DAMAGES. IN NO EVENT SHALL SPECTRUM'S LIABILITY, WHETHER UNDER CONTRACT OR WARRANTY, IN TORT OR OTHERWISE, EXCEED THE PURCHASE PRICE RECEIVED BY SPECTRUM FOR THE PRODUCT AT ISSUE AND "RECALL ACTION" EXPENSES. SPECTRUM SHALL NOT BE SUBJECT TO ANY OTHER OBLIGATIONS OR LIABILITIES, WHETHER ARISING OUT OF BREACH OF CONTRACT, WARRANTY, TORT (INCLUDING NEGLIGENCE AND STRICT LIABILITY) OR OTHER THEORIES OF LAW, WITH RESPECT TO PRODUCTS SOLD OR SERVICES RENDERED BY SPECTRUM, OR ANY UNDERTAKINGS, ACTS OR OMISSIONS RELATING THERETO.

Our Customer Service Department is ready to provide immediate attention to any questions, comments or concerns. They are available to answer your calls Monday through Friday from 7 am to 5 pm CST. In addition your product comments or concerns are welcome via e-mail at: spectrum@spectrumfurniture.com.

Warranty Table

Item	Warranty Period
<ul style="list-style-type: none"> Adjustable Crank/Electric Desk Legs Flat Panel Desk Gas Cylinders 	<ul style="list-style-type: none"> 1 Year
<ul style="list-style-type: none"> Adjustable Height Chair Parts – including frames, gas cylinders, wood and plastic parts, and control handles Adjustable Height Chair Parts Casters Adjustable Height Chair Upholstery In-Stock Upholstery Graded-In Fabrics and Customer Owned Material 	<ul style="list-style-type: none"> 7 Years 2 Years 2 Years No Warranty
<ul style="list-style-type: none"> Height Adjustable Columns and Lifts General Use Casters Electrical Keyboard/Mouse Trays 	<ul style="list-style-type: none"> 1 Year
<ul style="list-style-type: none"> Flat Panel Monitor Arm – General Parts Flat Panel Monitor Arm – Gas Cylinders 	<ul style="list-style-type: none"> 5 Years 2 Years
<ul style="list-style-type: none"> Computer Desk Chassis Cart Chassis Lectern Chassis 	<ul style="list-style-type: none"> 10 Years



205 Westwood Ave, Long Branch, NJ 07740
 Phone: 866-94 BOARDS (26273) / (732)-222-1511
 Fax: (732)-222-7088 | E-mail: sales@touchboards.com



INDOOR AIR QUALITY
 Indoor Advantage | Furniture

