



Touchboards

205 Westwood Ave, Long Branch, NJ 07740
Phone: 866-94 BOARDS (26273) / (732)-222-1511
Fax: (732)-222-7088 | E-mail: sales@touchboards.com



Actual installation.
Two Diversiboards
open and close like
a curtain in front of a
large format TV!

installation at:
QUIKSILVER 
www.quiksilver.com

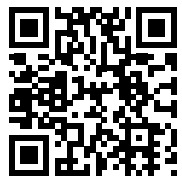

YouTube Video

Diversiboard MB (Marker Board)

Diversiboard Marker Board An industry FIRST, one-of-a-kind 100% steel panel surface designed for use in the classroom or boardroom. The Diversiboard "MB" or Marker Board, offers a GLOSSY surface perfect for any classroom or boardroom.

- + *Diversiboard is 100% steel, it will not warp like other dry erase boards!*
- + *Proprietary glossy white surface resists permanent marker which also eliminates ghosting*
- + *Mount over your chalk board to our patented **Diversitrack™** track mount system, our **Diversimount™** stationary system or flat to your wall!*
- + *It is frameless—fasteners are hidden for a very clean look*
- + *Add additional marker board space that can move to one side on **Diversitrack™***
- + *Deploy one or multiple 4x4 or 4x6 dry erase boards on the same **Diversitrack™** system OR in a "nested" configuration*

Revision 022616

TRACK TECHNOLOGY SYSTEMS, INC.

Corporate Address:
10053 Whitney Way, Fishers, IN 46037



CALL TOLL FREE:
1-800-995-3177

For more information, call our office, email
sales@diversitrack.com or visit diversitrack.com.



Diversiboard Marker Board

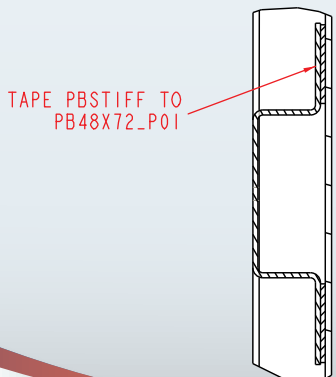
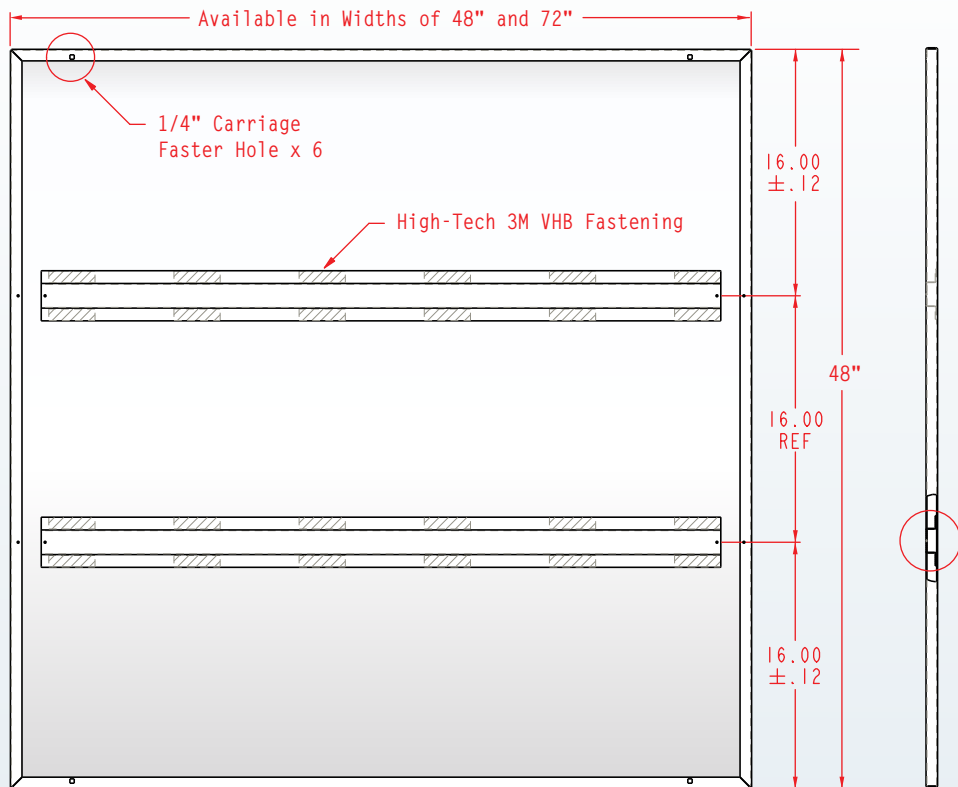

Diversiboard Marker Board Specifications

- + 18 gauge, 100% cold rolled steel construction
- + Surface flatness of +/- 0.0511 inch (1.3mm)
- + Double-formed 90 degree edges x 4 sides
- + Available sizes: 48"H x 48"W and 48"H x 72"W
- + Multiple horizontal stiffeners, steel, channeled
- + Channeled stiffeners adhered with high-tech 3M VHB
- + Custom sizes available

TRACK TECHNOLOGY SYSTEMS, INC.

10053 Whitney Way, Fishers, IN 46037
Email: sales@diversitrack.com



CALL TOLL FREE:
1-800-995-3177

Visit our website at: www.diversitrack.com

Diversitrack is patented and an official trademark of Track Technology Systems, Inc.
Diversimount is Patent Pending and an official trademark of Track Technology Systems, Inc.

