

# AVTEQ

## Easy Setup Guide

# Touchboards

205 Westwood Ave, Long Branch, NJ 07740  
Phone: 866-94 BOARDS (26273) / (732)-222-1511  
Fax: (732)-222-7088 | E-mail: sales@touchboards.com

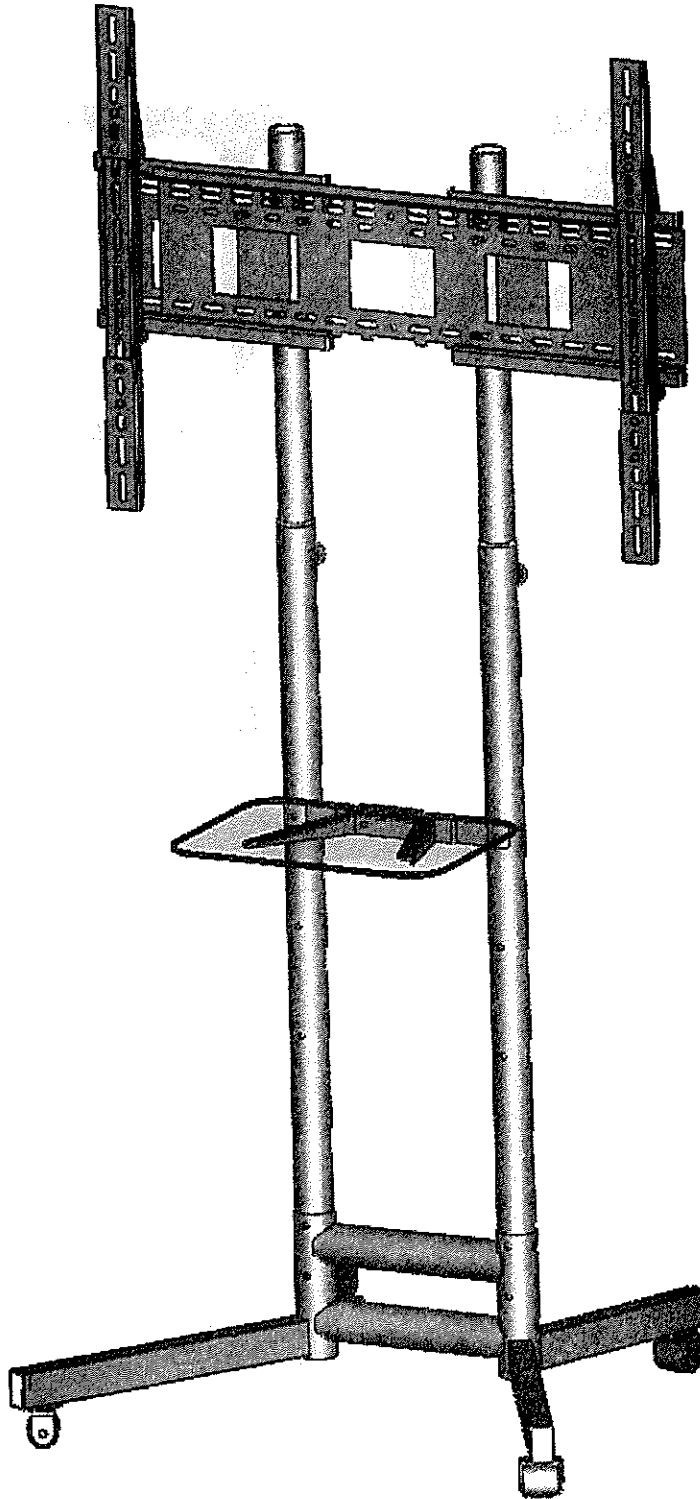

# RPS 200

Toll Free: 800 285 8315 Telephone: 214 905 9001 Facsimile: 214 905 9666

Be sure to read this entire manual thoroughly and you fully understand all instructions and warning before attempting to begin your installation.

This wall bracket will only support flat panel display (LCD, Plasma). The maximum load capacity is 150 pounds.

Always have someone assist you to lift and position your equipment.

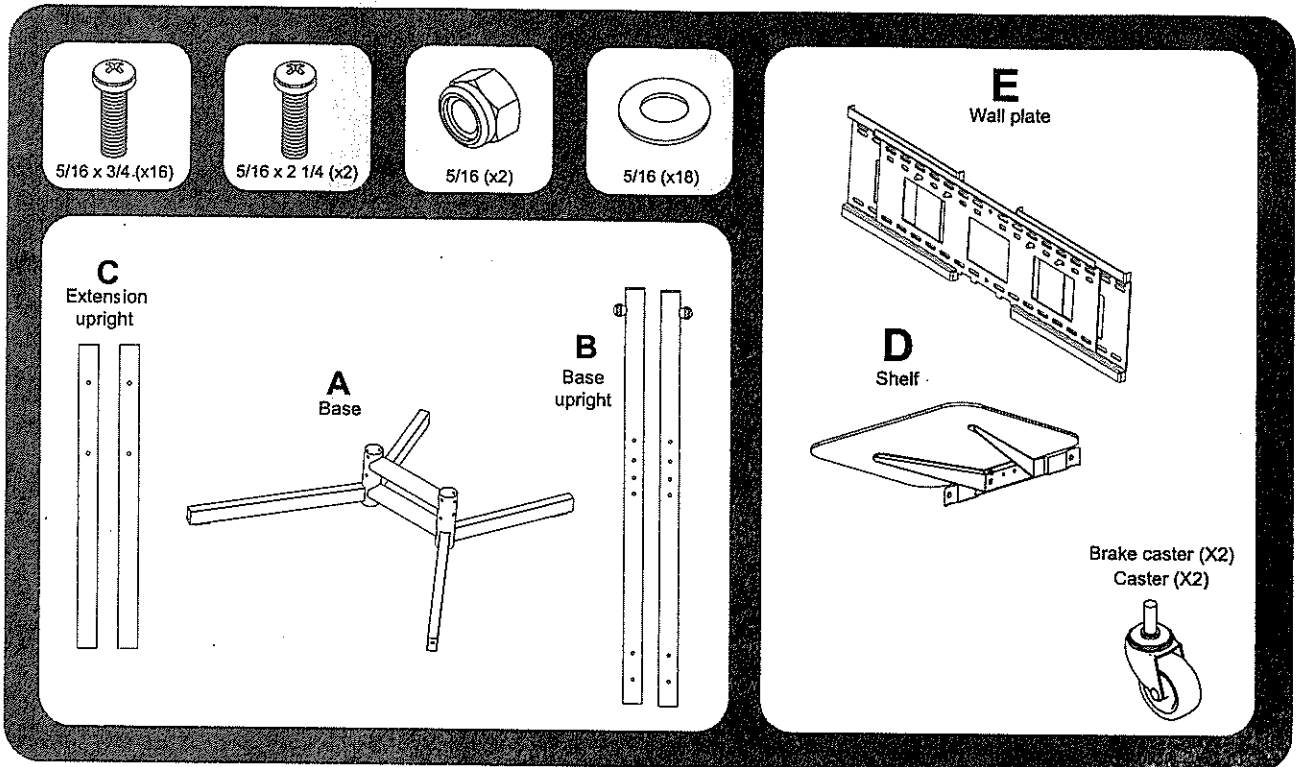

**1**

Install the caster as shown in Figure.

Caster with brakes should be installed on front of base(A) (Side with long legs).

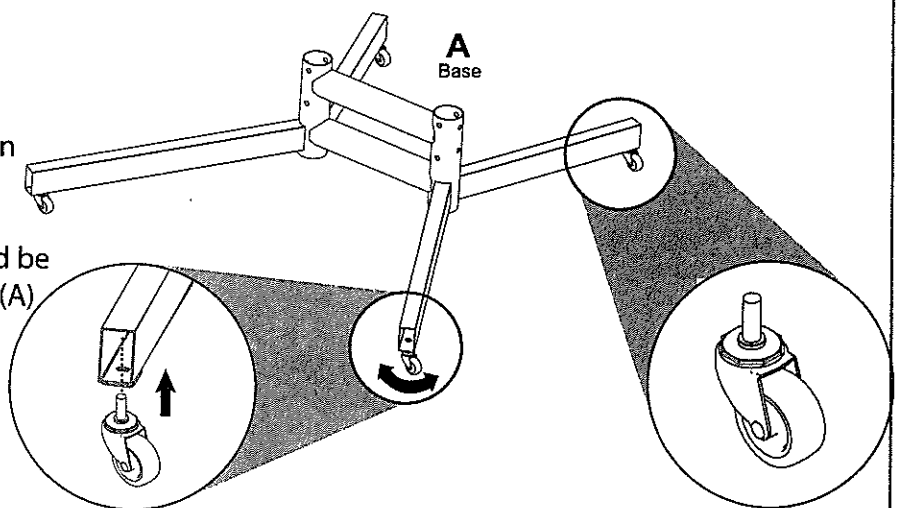

**2**

Mount base upright (B) to Base (A) using 5/16 x 3/4 screw and 5/16 washer.

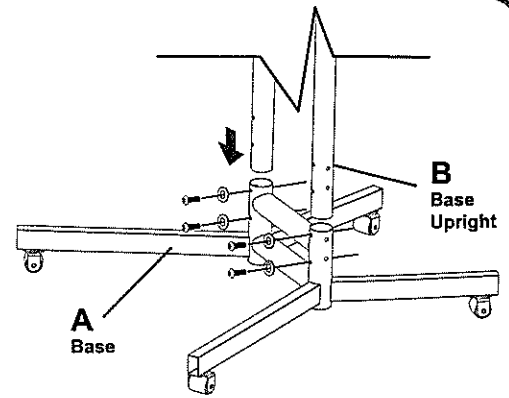

**3**

Insert the Extension Upright (C) into the Base Upright (B). Secure with the Adjustable Knobs.

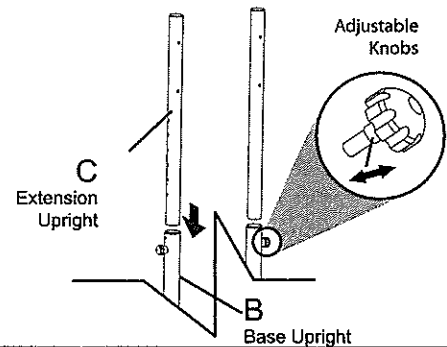

**4**

Install the Shelf (D) to the Base Upright (B) using the 5/16 x 3/4 screws and 5/16 washer

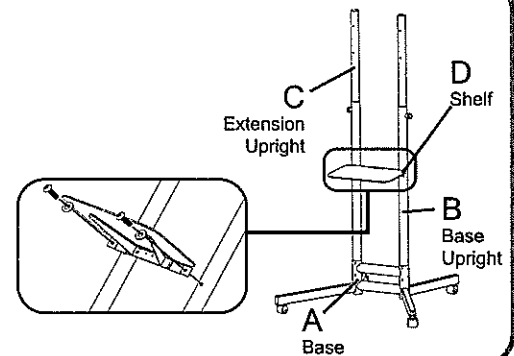

**5**

Mount the Wall Plate (E) to the Extension Upright (C) using 5/16 x 2 1/4 screws, 5/16 washer and 5/16 nuts.

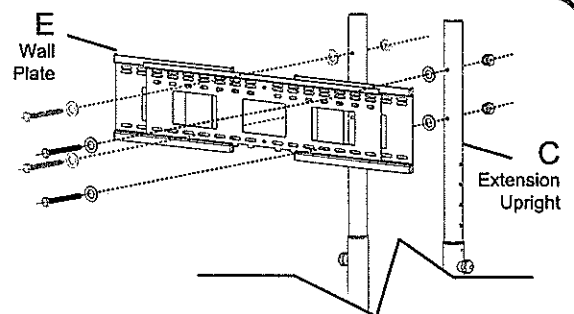

**6**

Instructions for mounting the display to the cart are included in the Wall Plate Box.