



BATTERY REPLACEMENT

This instrument is powered by a 9V battery. Use the following procedure to replace the battery.

1. Turn power off.
2. Position the instrument face down and remove the screw from the battery cover.
3. Slide off the battery cover and remove the battery.
4. Replace with a new 9V battery and reinstall the battery cover.

REPLACEMENT PARTS

Carrying CaseCat. # SV-600
 BatteryCat. # MN-1604

SERVICE

If the instrument fails to operate, check battery, fuse(s), leads, etc. and replace as necessary. If the instrument still does not operate, double check operating procedure as described in the instruction manual. If the instrument still malfunctions, place it with packing slip along with a brief description of the problem in sufficient cushioning material in a shipping carton. Be sure to indicate the serial number located on the back of the instrument. Amprobe is not responsible for damage in transit. Make certain your name and address also appears on the box as well as packing slip; ship prepaid via U.P.S. (where available) or Air Parcel Post insured to:

Service Division
 AMPROBE INSTRUMENT
 630 Merrick Road (use for U.P.S.)
 P.O. Box 329 (use for Parcel Post)
 Lynbrook, NY 11563-0329

Outside the USA, the local Amprobe representative will assist you.

OPERATING INSTRUCTIONS

for

AMPROBE® AC/DC Digital Clamp-On Models ACDC-600A and ACDC-600AT

See "PRECAUTIONS FOR PERSONAL AND INSTRUMENT PROTECTION" on Page 3

See "LIMITED WARRANTY" on Page 2

LIMITED WARRANTY

Congratulations! You are now the owner of an AMPROBE® instrument. It has been crafted according to the highest standards of quality and workmanship. This instrument has been inspected for proper operation of all of its functions. It has been tested by qualified factory technicians according to the long-established standards of AMPROBE INSTRUMENT.

Your AMPROBE instrument has a limited warranty against defective materials and/or workmanship for one year from the date of purchase provided the seal is unbroken or, in the opinion of the factory, the instrument has not been opened, tampered with, or taken apart.

Should your instrument fail due to defective materials, and/or workmanship during the one-year warranty period, return it along with a copy of your dated bill-of-sale which must identify instrument by model number and serial number.

IMPORTANT: For your protection, please use the instrument as soon as possible. If damaged, or should the need arise to return your instrument, place it in a shipping carton packed with sufficient cushioning material. It must be securely wrapped, Amprobe is not responsible for damage in transit. Be sure to include a packing slip (indicating model and serial number) along with a brief description of the problem. Make certain your name and address appears on the box as well as packing slip.

Ship prepaid via Air Parcel Post insured or U.P.S (where available) to:

Service Division
AMPROBE INSTRUMENT
630 Merrick Road (For U.P.S.)
P.O. Box 329 (For Parcel Post)
Lynbrook, NY 11563-0329

Outside the U.S.A. the local Amprobe representative will assist you. Above limited warranty covers repair and replacement of instrument only and no other obligation is stated or implied.

PRECAUTIONS FOR PERSONAL AND INSTRUMENT PROTECTION

1. Read these instructions thoroughly and follow them carefully.
2. In many instances, you will be working with dangerous levels of voltage and/or current. Therefore, it is important that you avoid direct contact with any uninsulated, current-carrying surfaces. Appropriate insulating gloves, clothing and eye protection should be worn.

INTRODUCTION

Amprobe's Model ACDC-600A and ACDC-600AT Digital Clamp-Ons are quick AC and DC current only measuring instruments.

Model ACDC-600A is an average sensing instrument calibrated to read out in RMS.

Model ACDC-600AT is a TRUE RMS measuring instrument used for accurate measurement of loads with distorted waveforms or systems suspected of having harmonics.

Unpacking and Inspection of Contents

Upon removing your new instrument from its packing, you should have the following items:

1. Instrument (ACDC-600A or ACDC-600AT).
2. Carrying case model SV-600.
3. Operator's manual.

FIG. 1

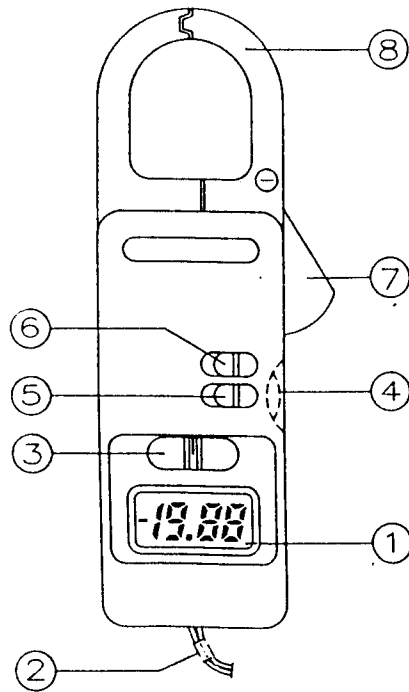

FRONT PANEL

Refer to Fig.1 and the following numbered steps to familiarize yourself with the instrument's front panel controls.

1. **Digital Display** - The digital display has a 3 1/2 digit LCD readout (maximum reading 1999) plus annunciators for AUTO (-) POLARITY, DECIMAL POINT, (LOW BATTERY) , DC, AC, and HOLD.
2. **Wrist Strap** - Prevents the instrument from slipping off the hand while in use.
3. **Function Switch** - Slide switch is used to select the range desired or to turn the instrument off.
4. **DC Zero Adjust Knob** - Zero adjusts display on DC current ranges.
5. **AC/DC Slide Switch** - Selects AC or DC for measurement.
6. **Data Hold Switch** - Holds or freezes display reading.
7. **Trigger** - Press the lever to open the transformer jaws.
8. **Transformer Jaws** - Designed to pick up the current flowing through the conductor.

SPECIFICATIONS

Display: 3 1/2 Digit Liquid Crystal Display (LCD).

Polarity: "-" indicated, "+" implied.

Overrange Indication: "1" or "-1" only displayed.

Measuring Rate: 2 times per second

Position Error: +/- 1% of reading.

Type of Sensor: Hall Effect Device.

Low Battery Indicator: "" is displayed when the battery voltage drops below the operating voltage.

Operating Temperature: 0°C thru +50°C (+32°F thru +120°F), <75% R.H.

Storage Temperature: -20°C thru +60°C (-4°F thru +140°F), <80% R.H.

Power Supply: Single 9V battery. (NEDA 1604A or IEC 6LF22).

Battery Life: 40+ Hours typical (alkaline)

Max. Conductor Size: 34mm Dia. (1.33 inches) or 20mm x 40mm (.78 x 1.56 inches) bus bar.

Size: 60mm (W) x 203mm (L) x 29mm (H), or 2.34"(W) x 7.92" (L) x 1.13" (H).

Weight: 310g (11 oz).

Accuracy: ±(% reading + number of digits) at 23°C ±5°C, less than 75% R.H.

FUNCTION	RANGE	RESOLUTION	ACCURACY
DCA	0-20A	0.1A	±(1.9%rdg+5dgt)
	20A-200A	0.1A	±(1.9%rdg+3dgt)
	200A-600A	1A	±(1.9%+3dgt)
ACA	0-20A	0.1A	±(1.9%rdg+7dgt)
	20A-200A	0.1A	±(1.9%rdg+5dgt)
	200A-600A	1A	±(1.9%rdg+5dgt)

Frequency Response: 40Hz – 400Hz for sine wave
(or crest factor = 1.4 – 2.0 ACDC-600AT)

Data Hold: Hold display reading for all functions and ranges.

Temperature Coefficient: 0.2 x (spec. Acc'y)/°C,
<18°C or >28°C

PRECAUTIONS AND PREPARATIONS FOR USE

READ and UNDERSTAND ALL INSTRUCTIONS BEFORE USING THIS INSTRUMENT!
IF YOU HAVE ANY QUESTIONS REGARDING THESE INSTRUCTIONS OR INSTRUMENT OPERATION PLEASE CALL: 1-800-477-VOLT (8658)

1. Make sure that the battery is connected properly.
2. Operate the instrument only in the temperature range of 0°C thru +50°C (+32°F thru +120°F), <75% R.H.
3. Do not store this instrument in temperatures higher than +60°C (+140°F) or humidity >80%, or in direct sunlight.
4. Do not replace battery with function switch in "ON" position.
5. If instrument is not going to be used for a long period of time, remove the battery.
6. Turn power off after use.
7. Auto Power OFF – The instrument will automatically shut itself down after approximately 30 minutes after power ON.

AC CURRENT MEASUREMENT

IMPORTANT

See "PRECAUTIONS FOR PERSONAL AND INSTRUMENT PROTECTION"

1. Set the AC/DC switch at AC position.
2. Set the function switch at the range desired. Always start at the highest range setting.
3. Press the trigger to open the transformer jaws and clamp one conductor only, make sure that the jaw is firmly closed around the conductor, then read the reading from digital display.

DC CURRENT MEASUREMENT

IMPORTANT

See "PRECAUTIONS FOR PERSONAL AND INSTRUMENT PROTECTION"

1. Set the AC/DC switch at DC position.
2. Set the function switch at the range desired. Always start at the highest range setting.
3. Adjust the "DCA Zero Adj. knob" until the display shows "0".
4. For DC measurement, the reading is a positive value when the current flows from the rear side of the case to the front side of the case as Fig. 2.
5. Press the trigger to open the transformer jaws and clamp one conductor only, make sure that the jaw is firmly closed around the conductor, then read the reading from the digital display.

