



# MX514 Digital Projector



205 Westwood Ave, Long Branch, NJ 07740  
 Phone: 866-94 BOARDS (26273) / (732)-222-1511  
 Fax: (732)-222-7088 | E-mail: sales@touchboards.com



## Highlights

- Power Saving Functions
- HDMI connectivity
- Thoughtful Design

<b>Projection System</b>	DLP		
<b>Native Resolution</b>	XGA(1024x768)		
<b>Brightness</b>	2700 ANSI lumens		
<b>Contrast Ratio</b>	10000:1		
<b>Display Color</b>	1.07 Billion Colors		
<b>Lens</b>	F=2.51-2.69, f=21.95-24.18mm		
<b>Aspect Ratio</b>	Native 4:3 (5 aspect ratio selectable)		
<b>Throw Ratio</b>	1.97-2.17(50"@2m)		
<b>Image Size (Diagonal)</b>	30" to 300"		
<b>Zoom Ratio</b>	1.1:1		
<b>Lamp Type</b>	190W		
<b>Lamp(Normal/Economic/SmartEco Mode)*</b>	4500/6000/6500 hours		
<b>Keystone Adjustment</b>	1D, Vertical ± 40 degrees		
<b>Projection Offset</b>	120% ±5%		
<b>Resolution Support</b>	VGA(640 x 480) to UXGA(1600 x 1200)		
<b>Horizontal Frequency</b>	31-90KHz		
<b>Vertical Scan Rate</b>	50-120Hz		
<b>Compatibility</b>	HDTV Compatibility	480i, 480p, 576i, 576p, 720p, 1080i, 1080p	
	Video Compatibility	NTSC, PAL, SECAM	
	3D Compatibility	PC: 120Hz Frame Sequential 3D for resolutions up to WXGA, PC: 60Hz Top-bottom 3D for resolutions up to SXGA+ Video: 60Hz Frame Sequential 3D for resolutions up to 480i	
<b>Interface</b>	Computer in (D-sub 15pin)	x 2(Share with component)	
	Monitor out (D-sub 15pin)	x1	
	Composite Video in (RCA)	x 1	
	S-Video in (Mini DIN 4pin)	x 1	
	Audio in (Mini Jack)	x 1	
	Audio out (Mini Jack)	x 1	
	Speaker	2W x 1	
	HDMI V1.3	x 1	
	USB (Type Mini B)	x 1 (Download & Page up/down)	
	RS232 (DB-9pin)	x 1	
<b>Dimensions</b>	Dimensions(W x H x D)	302 x 124 x 232.7 mm	
	Weight	2.45kg(5.39lbs)	
<b>Power</b>	Power Supply	AC 100 to 240 V, 50/60 Hz	
	Power Consumption	245W, Standby < 1W	
<b>Audible Noise</b>	27/25 dB (Normal/Economic mode)		
<b>On-Screen Display Languages</b>	English/ France/ Germany/ Italian/ Spanish/ Russian/ Traditional Chinese/ Simplified Chinese/ Japanese/ Korean/ Swedish/ Dutch/ Turkish/ Czech/ Portuguese/ Thai/ Polish/ Hungarian/ Croatian/ Romanian/ Norwegian/ Danish/ Bulgaria/ Finnish/ Indonesian/ Greek/ Hindi/ Arabic (28 Languages)		
<b>Picture Modes</b>	Dynamic/Presentation/sRGB/Cinema/User 1/User 2		
<b>Accessories</b>	<b>Standard</b>	<b>Optional</b>	
	Remote Control w/ Battery	Presentation Plus	P/N: 65J9306.002
	Power Cord (by region)	Spare Lamp Kit	P/N: 5JJ5E05.001
	User Manual CD	Ceiling Mount	P/N: 5JJ2K01.001
	Quick Start Guide	3D Glasses	P/N: 5JJ0T14.011
	Warranty Card (by region)	Carry Bag	
	VGA(D-sub 15pin) Cable		

\*Lamp life results will vary depending on environmental conditions and usage. Actual product's features and specifications are subject to change without notice.

## Distance Chart

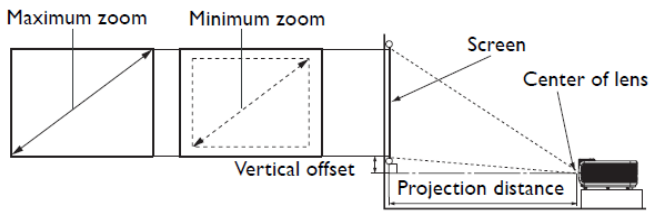

MW516

Screen size		Distance from screen (mm)			Vertical offset (mm)		
Diagonal	W	H	Min length	Average		Max length	
Inch	mm	(mm)	(mm)	(max. zoom)		(min. zoom)	
30	762	646	403	1018	1127	1235	61
40	1016	861	538	1273	1420	1567	83
50	1270	1077	673	1564	1731	1897	105
60	1524	1292	807	1871	2047	2223	126
80	2032	1723	1077	2435	2658	2881	164
100	2540	2153	1346	3014	3276	3538	205
120	3048	2584	1615	3594	3894	4194	251
150	3810	3230	2019	4465	4823	5180	313
200	5080	4307	2692	5916	6369	6822	416
220	5588	4738	2961	6496	6987	7478	457
250	6350	5384	3365	7367	7916	8464	521
300	7620	6461	4038	8818	9462	10106	624

## Wall mount Chart

Ceiling mount screws:  
M4 x 8 (Max. L = 8 mm)

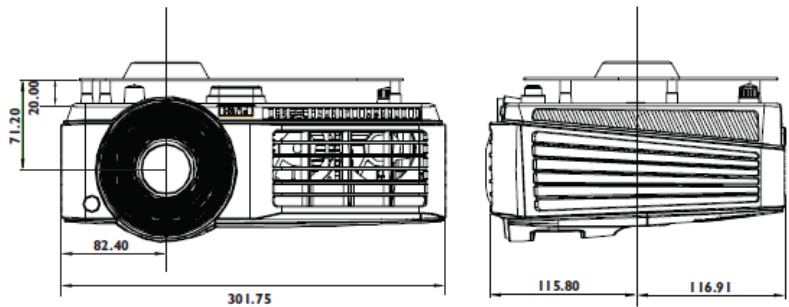
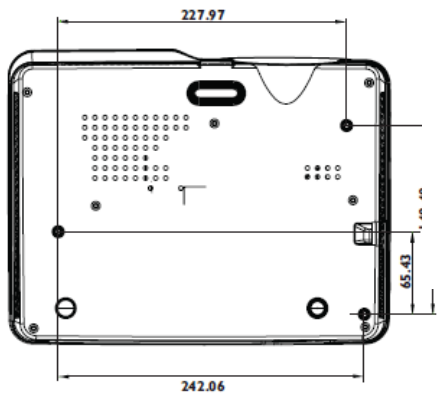

Unit: mm

## Dimension

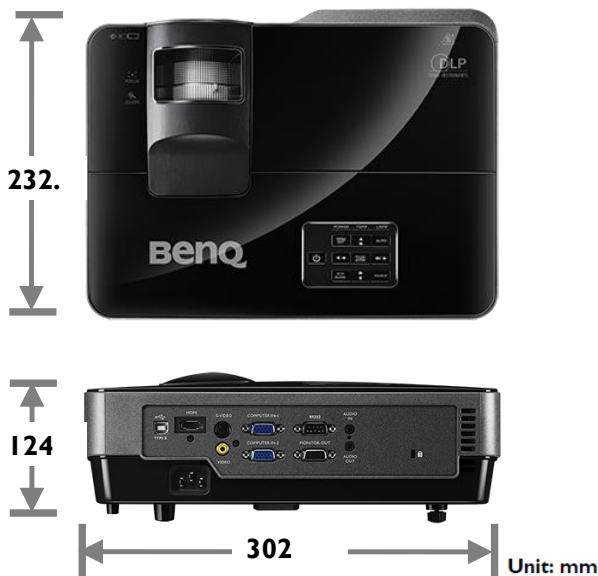

# Touchboards

205 Westwood Ave, Long Branch, NJ 07740  
Phone: 866-94 BOARDS (26273) / (732)-222-1511  
Fax: (732)-222-7088 | E-mail: sales@touchboards.com