

INSTALLATION INSTRUCTIONS

Small Flat Panel Mounts

Model: F-Series



205 Westwood Ave, Long Branch, NJ 07740
Phone: 866-94 BOARDS (26273) / (732)-222-1511
Fax: (732)-222-7088 | E-mail: sales@touchboards.com

This Instruction Manual covers most of the F-Series wall and desk mounts, as well as selected F-Series pole mounts.

NOTE: Some F-Series mounts (e.g., Table, Pole) and F-Series accessories have separate Instruction Manuals.

See Specifications on page 3 for a complete list of models covered by this Instruction Manual.

IMPORTANT ! : If an accessory such as an optional laptop tray is being installed, complete all required installation procedures within this document prior to installing the accessory.

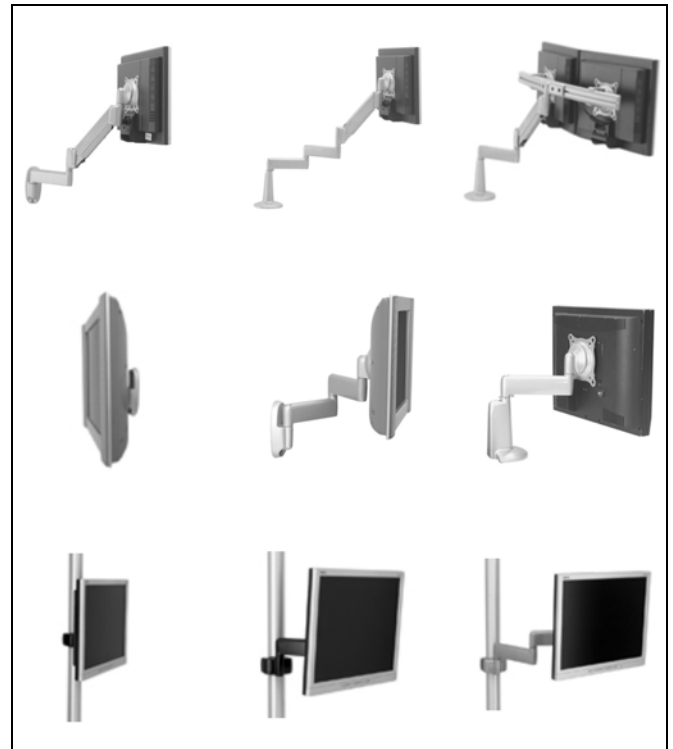

F-Series Mounts (Examples)

BEFORE YOU BEGIN



WARNING: It is the installer's responsibility to make sure all components are properly assembled and installed using the instructions provided. Failure to read, thoroughly understand, and follow all instructions can result in serious personal injury, damage to equipment, or voiding of factory warranty.

- If you have any questions about these instructions or your specific installation, contact Chief Manufacturing at 1-800-582-6480 or 952-894-6280.

DISCLAIMER:

CSAV, Inc., and its affiliated corporations and subsidiaries (collectively, "CSAV"), intend to make this manual accurate and complete. However, CSAV makes no claim that the information contained herein covers all details, conditions or variations, nor does it provide for every possible contingency in connection with the installation or use of this product. The information contained in this document is subject to change without notice or obligation of any kind. CSAV makes no representation of warranty, expressed or implied, regarding the information contained herein. CSAV assumes no responsibility for accuracy, completeness or sufficiency of the information contained in this document.



CHIEF MANUFACTURING INC.
1-800-582-6480 952-894-6280 FAX 952-894-6918
8401 EAGLE CREEK PARKWAY, STE 700
SAVAGE, MINNESOTA 55378 USA

8832-000173 RevB
©2007 Chief Manufacturing



IMPORTANT WARNINGS AND CAUTIONS!

WARNING: A WARNING alerts you to the possibility of serious injury or death if you do not follow the instructions.

CAUTION: A CAUTION alerts you to the possibility of damage or destruction of equipment if you do not follow the corresponding instructions.



WARNING: Failure to provide adequate structural strength for this component can result in serious personal injury or damage to equipment! It is the installer’s responsibility to make sure the structure to which this component is attached can support five times the combined weight of all equipment. Reinforce the structure as required before installing the component.



WARNING: Exceeding the weight capacity can result in serious personal injury or damage to equipment! It is the installer’s responsibility to make sure the combined weight of all components does not exceed the maximum support weight as stated in the Specifications on page 3.



WARNING: Allowing any part of your body or component cables to be caught between movable parts can result in serious personal injury or damage to equipment!



CAUTION: Overtightening fasteners may result in improper operation, excessive wear or damage to equipment, and/or voiding of factory warranty!

CONTENTS

TOOLS REQUIRED FOR INSTALLATION..... 2

SPECIFICATIONS 3

MOUNT INSTALLATION 4

DISPLAY INSTALLATION..... 7

ARRAY ASSEMBLY (DUAL / TRIPLE DISPLAY; FMA-220/-320 ONLY) 10

MULTI-DUAL ARM ASSEMBLY (FCY-210/-220 ONLY) 11

CABLE MANAGEMENT 13

ADJUSTMENT 14

TOOLS REQUIRED FOR INSTALLATION

- Phillips Screwdriver, #1 and #2
- Drill (All Wall Mounts)
- 1/8" Drill Bit (All Wall Mounts)
- 2.5mm Hex Key (approximately 3/32"; provided with Desk Mounts)
- 5/32" Hex Key (provided with applicable F-Series mounts)
- 3/16" Hex Key (provided with all F-Series mounts)

NOTE: Other tools may be required depending on your method of installation.

SPECIFICATIONS**Table 1: Mounts**

MODEL	NO. OF DISPLAYS TRAYS	SUPPORTING STRUCTURE	NO. OF MOUNTING ARMS	ADJUSTABLE HEIGHT	MAX. EXTENSION (INCHES)	MIN. CLOSED DEPTH (INCHES)	MAX. SUPPORT WEIGHT (LBS.)
FWP-110	Single	Wall	None	No	None	2.9	40
FWV-110	Single	Wall	Single	Yes	13	2.2	25
FWS-110	Single	Wall	Single	No	9.5	2.2	40
FWG-110	Single	Wall	Dual	Yes	19.5	2.2	25
FWD-110	Single	Wall	Dual	No	16	2.2	40
FWB-110	Single	Wall	Triple	Yes	26	2.2	25
FCV-110	Single	Desk	Single	Yes	13.5	2.2	25
FCS-110	Single	Desk	Single	No	10	2.2	40
FCG-110	Single	Desk	Dual	Yes	20	2.2	25
FCD-110	Single	Desk	Dual	No	16.5	2.2	40
FCB-110	Single	Desk	Triple	Yes	26.5	2.2	25
FPP-110	Single	Pole	None	No	None	2.2	40
FPS-110	Single	Pole	Single	No	9.5	2.2	40
FPD-110	Single	Pole	Dual	No	16	2.2	40
FGL-110	Tray	Desk	Single	Yes	29.5	14	18
FGL-220	Single/Tray	Desk	Dual	Yes	19.5	14	40 total
FCY-210	Dual	Desk	Multi-Dual	Yes (one arm)	20	2.2	40
FCY-220	Dual	Desk	Multi-Dual	Yes (two arms)	20	2.2	40

MOUNT INSTALLATION

INSTALLATION TO WALL

1. Verify that you have the following parts:

Item	Description	Qty
10	MOUNT, Wall, F-Series	1
20	BRACKET, Wall	1
30	SCREW, Phillips Pan Sheet Metal, #10 x 2-1/2"	2
40	WASHER, Flat Machine Screw, #10	2

2. Determine location for mount keeping in mind display size, extension, height adjustment (if applicable), and pitch/roll requirements. Bracket (20) **MUST** be installed into wood stud.
3. Using bracket (20) as a template, drill two 1/8" diameter pilot holes through top and bottom holes of bracket (20) into wall structure (See Figure 1).

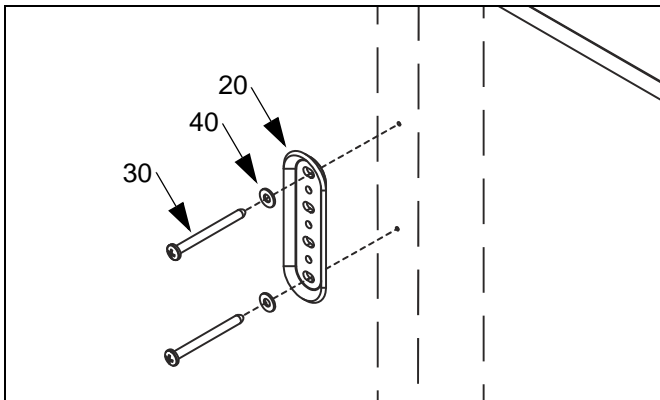

Figure 1: Install Wall Bracket

4. Using Phillips screwdriver, install screws (30) through washers (40), bracket (20), and drywall into wood stud (See Figure 1). Ensure bracket (20) is vertical, then tighten screws (30).

IMPORTANT ! : Overtightening screws (30) may cause bracket (20) to compress into soft wall surface, resulting in difficult mount installation or improper engaging of set screw in step 6.

IMPORTANT ! : IF you will be installing a SINGLE display with RECESSED mounting holes, then proceed to "DISPLAY INSTALLATION" *before continuing* with this mount installation procedure.

5. Insert top of mount (10) over lip on top of bracket (20) (See Figure 2). Swing mount (10) down flush against wall.

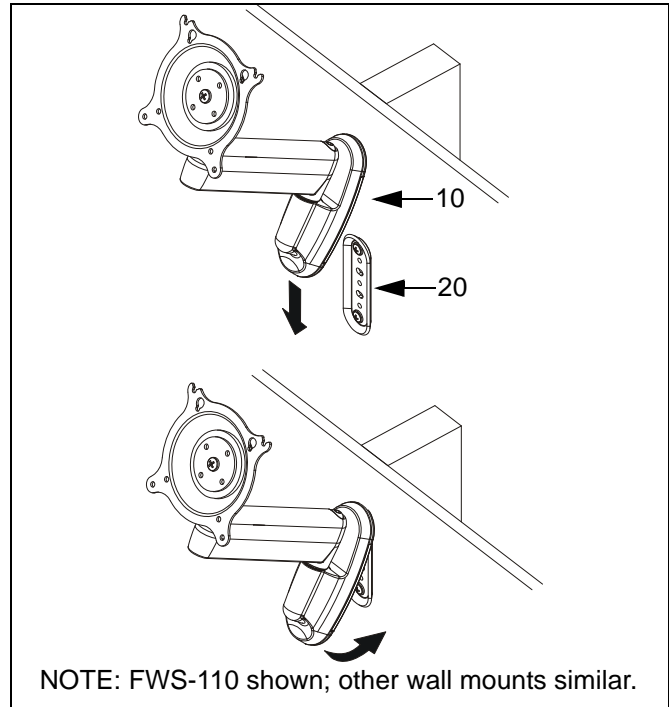

Figure 2: Install Wall Mount

6. Tighten set screw using 5/32" hex key (See Figure 3). Ensure set screw engages *back* side of bracket (20) to properly secure mount.

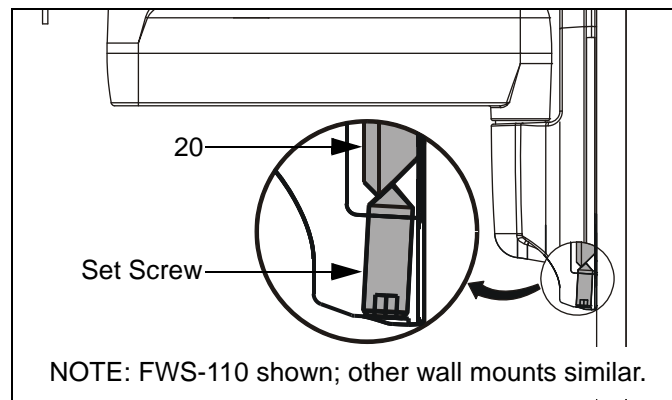

Figure 3: Tighten Set Screw

7. Proceed to "CABLE MANAGEMENT" (for SINGLE display with RECESSED mounting holes), or to "DISPLAY INSTALLATION" (for all other display configurations).

INSTALLATION TO DESK

Two installation options exist:

- Edge Installation
- Hole (Grommet) Installation; requires 3/8" to 3" diameter hole and access to the bottom of the desk

ASSEMBLY

1. Verify that you have the following parts:

Item	Description	Qty
10	MOUNT, Desk, F-Series	1
20	BRACKET, Grommet	1
30	SCREW, Button Head Cap, 5/16"-18 x 4"	1
40	BUMPER, Adhesive	6

- Determine approximate location for mount keeping in mind display size, extension, height adjustment (if applicable), and pitch/roll requirements.
- Peel backing from adhesive bumpers (40) and attach to bottom of mount (10) (See Figure 4).

NOTE: One extra bumper (40) included for convenience.

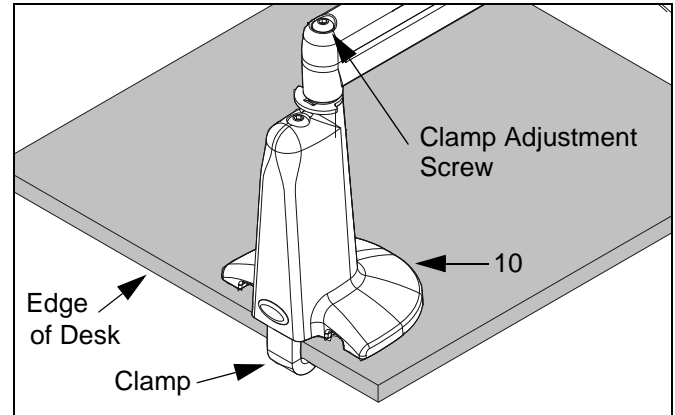

Figure 5: Desk Mount - Edge Installation

- If you are installing:
 - SINGLE display with RECESSED mounting holes: Proceed to "CABLE MANAGEMENT."
 - FCY-210/-220: Proceed to "MULTI-DUAL ARM ASSEMBLY."
 - ALL other display configurations: Proceed to "DISPLAY INSTALLATION."

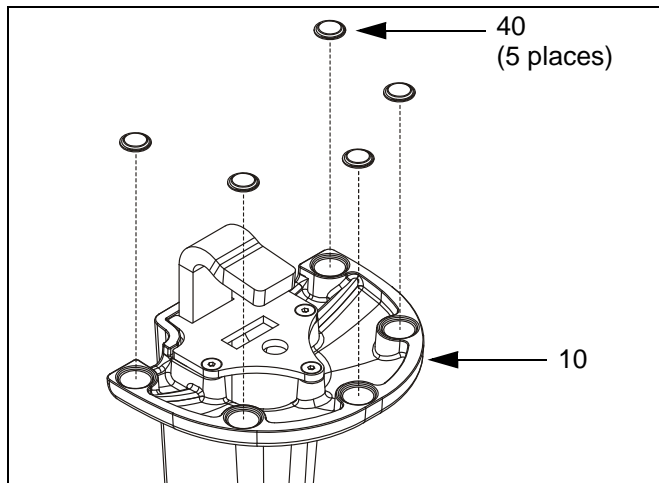

Figure 4: Install Bumpers

EDGE INSTALLATION

IMPORTANT ! : IF you will be installing a SINGLE display (including FCY-210/-220) with RECESSED mounting holes, then proceed to "DISPLAY INSTALLATION" *before continuing* with this mount installation procedure.

NOTE: Bracket (20) and screw (30) are not used in this installation.

- Slip mount (10) over edge of desk so that clamp fully contacts desk edge. Using 3/16" hex key, securely tighten clamp adjustment screw (See Figure 5).

HOLE (GROMMET) INSTALLATION

- Using 2.5mm hex key, remove and retain baseplate and three attach screws from bottom of mount (10) (See Figure 6).

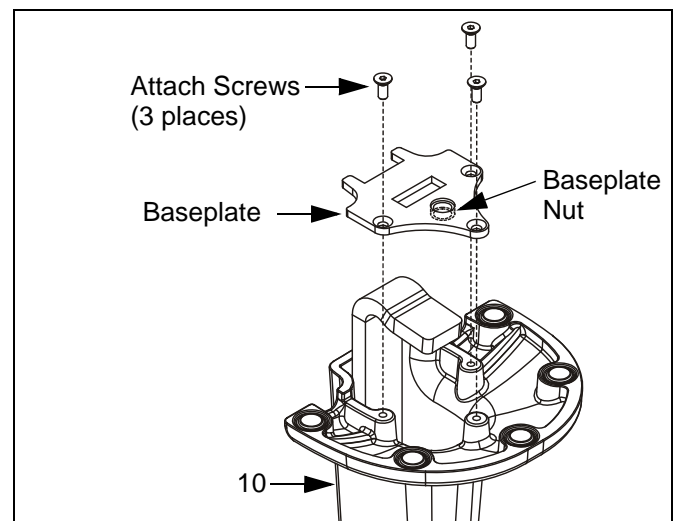

Figure 6: Baseplate

- Using 3/16" hex key, remove clamp adjustment screw, washer, and clamp (See Figure 7). Retain clamp adjustment screw and washer for later use.

NOTE: Clamp will not be used for Hole (Grommet) Installation.

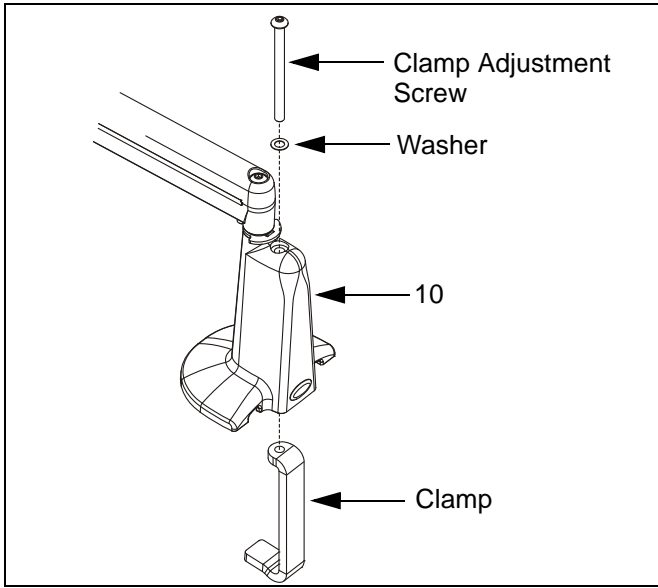

Figure 7: Remove Clamp Adjustment Screw

3. Using 2.5mm hex key, re-install baseplate with three retained attach screws. Ensure baseplate nut faces *interior* of mount (See Figure 6). Tighten securely.

IMPORTANT ! : IF you will be installing a SINGLE display (including FCY-210/-220) with RECESSED mounting holes, then proceed to "DISPLAY INSTALLATION" *before continuing* with this mount installation procedure.

4. From below desk, insert retained clamp adjustment screw and washer through bracket (20) and up through hole in desk (See Figure 8). Using 3/16" hex key, thread screw into baseplate nut but do not tighten completely at this time.

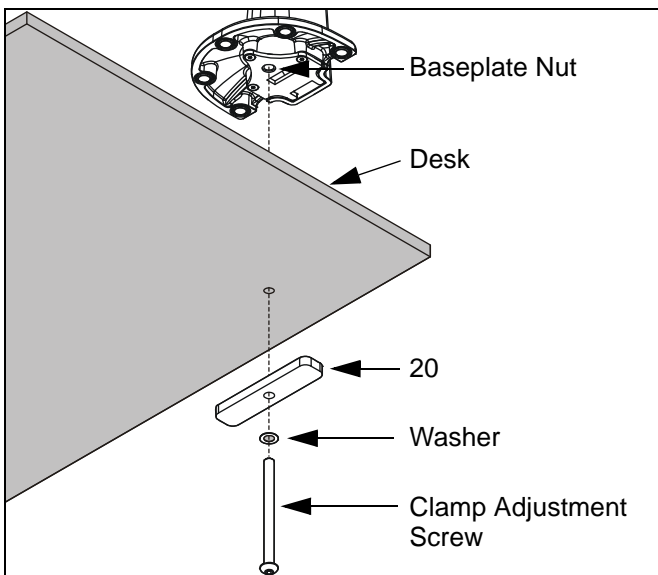

Figure 8: Desk Mount - Hole Installation

5. Center mount (10) over hole. Using 3/16" hex key, securely tighten screw.
6. Drop screw (30) into open (unused) clamp adjustment hole on top of mount (for appearance only).
7. If you are installing:
 - SINGLE display with RECESSED mounting holes: Proceed to "CABLE MANAGEMENT."
 - FCY-210/-220: Proceed to "MULTI-DUAL ARM ASSEMBLY."
 - ALL other display configurations: Proceed to "DISPLAY INSTALLATION."

INSTALLATION TO POLE

1. Verify that you have the following parts:

Item	Description	Qty
10	MOUNT, Pole, F-Series	1
20	CLAMP, Back	1
30	SCREW, Button Head Cap, 1/4"-20 x 1-1/8"	3

IMPORTANT ! : IF you will be installing a SINGLE display with RECESSED mounting holes, then proceed to "DISPLAY INSTALLATION" *before continuing* with this mount installation procedure.

2. Determine approximate location for mount keeping in mind display size, extension, height adjustment (if applicable), and pitch/roll requirements.
3. Place mount (10) against pole, with clamp (20) on opposite side of pole (See Figure 9). Using 5/32" hex key, loosely assemble with screws (30).

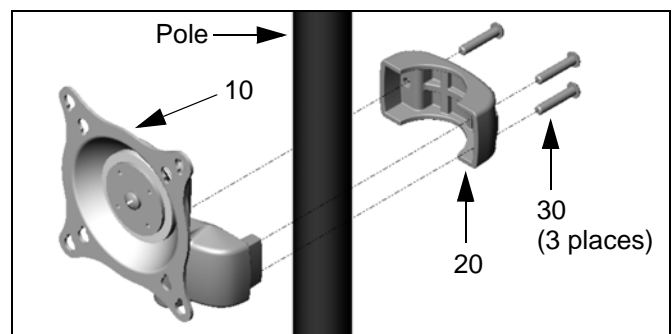

Figure 9: Pole Mount Installation

4. Position mount at desired height and orientation. Tighten screws (30) securely.
5. Proceed to "CABLE MANAGEMENT" (for SINGLE display with RECESSED mounting holes), or to "DISPLAY INSTALLATION" (for all other display configurations).

DISPLAY INSTALLATION

SINGLE DISPLAY AND FCY-210/-220

NOTE: If you are installing DUAL / TRIPLE displays FMA-220/-320, then proceed to page 9.

The mounting holes on the back of your display will either be *flush with* the back surface, or *recessed into* the back surface. Refer to the applicable installation procedure.

FLUSH MOUNTING HOLES

1. Verify that you have the following parts:

Item	Description	Qty
10	MOUNT, F-Series	1
20	SCREW, Phillips Pan Machine, M4 x 12mm	4



CAUTION: Using screws of improper size may damage your display! Proper screws will easily and completely thread into display mounting holes.



CAUTION: Inadequate thread engagement in display may cause display to fall! Back out screws **ONLY** as necessary to allow installation of Centris bracket!

2. Ensure Centris bracket is able to swivel and tilt easily, yet still be tight enough to hold display in desired position. Adjust as required before proceeding. See "ADJUSTMENT" for detail.
3. Using Phillips screwdriver, carefully install two screws (20) into the *upper* mounting holes on the display. Thread screws completely into display, then back out 3 complete turns.
4. Pick up and align display so that screws (20) (installed on the back of the display in the previous step) fit into the mounting holes on the Centris bracket; rotate the bracket as required (See Figure 10). Lower the display firmly into place.

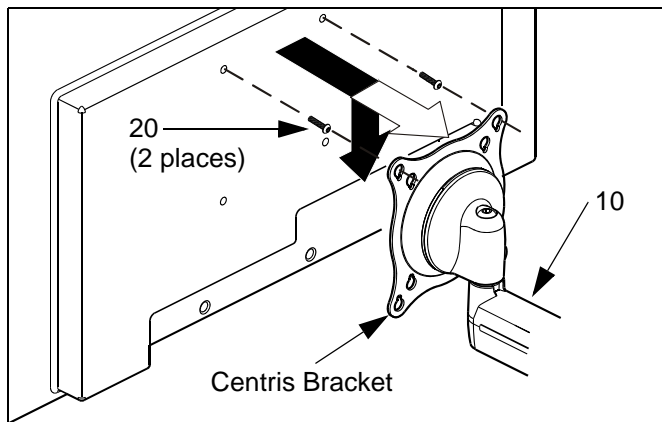

Figure 10: Single Display - Flush Mount

5. Using Phillips screwdriver, install two remaining screws (20) through the *lower* mounting holes in Centris bracket into the display.
6. Tighten all four screws (20). Do not overtighten!
7. FCY-210/-220 Only: Repeat Steps 1-6 for second display.
8. Proceed to "CABLE MANAGEMENT."

RECESSED MOUNTING HOLES

1. Verify that you have the following parts:

Item	Description	Qty
10	MOUNT, F-Series	1
20	SCREW, Phillips Pan Machine, M4 x 20mm	4
30	SCREW, Phillips Pan Machine, M4 x 30mm	4
40	SPACER, Nylon, 3/8" long	4
50	SPACER, Nylon, 3/4" long	4

2. Ensure Centris bracket is able to swivel and tilt easily, yet still be tight enough to hold display in desired position. Adjust as required before proceeding. See "ADJUSTMENT" for detail.
3. Carefully place display face down on protective surface.
4. Determine depth of recessed mounting holes relative to back surface of display (against which Centris head will contact).
5. Select proper length spacer and screw from table below:

NOTE: All spacers used should be the same length. If the recess depths result in multiple spacer lengths, then select the longer spacer.

IF recess DEPTH is:	THEN use spacer:	AND screw:
3/8" or less	40 (3/8" long)	20 (M4 x 20mm)
More than 3/8" up to and including 3/4"	50 (3/4" long)	30 (M4 x 30mm)

6. Place the four selected spacers over each of the mount holes on the back of the display.
7. Pick up and orient the mount (10) so that the mounting holes in the Centris bracket are aligned with the holes in the spacers; rotate the bracket as required (See Figure 11).

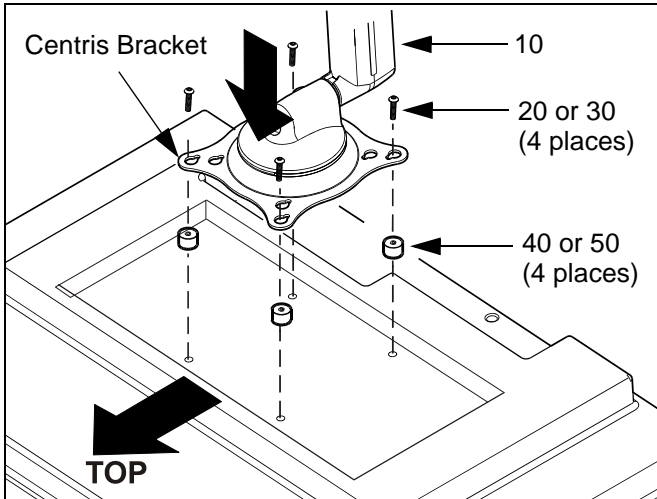

Figure 11: Single Display - Recessed Mount



CAUTION: Using screws of improper size may damage your display! Proper screws will easily and completely thread into display mounting holes.

8. Using Phillips screwdriver, install four selected screws through the mounting holes in Centris bracket, through the spacers, into the display (See Figure 11). Tighten all four screws. Do not overtighten!
9. FCY-210/-220 Only: Repeat Steps 1-6 for second display.
10. Continue with "MOUNT INSTALLATION."

DUAL / TRIPLE DISPLAY (FMA-220/-320 and KGL-220 ONLY)

The mounting holes on the rear of your display will either be flush with the rear surface, or recessed into the rear surface. Refer to the applicable installation procedure.

FLUSH MOUNTING HOLES

1. Verify that you have the following parts:

Item	Description	Qty
10	CENTRIS HEAD, Dual Knob Assembly	2-3
20	SCREW, Phillips Pan Machine, M4 x 12mm	4 per head

2. Carefully place display face down on protective surface.
3. Place the Centris head (dual knob assembly) onto the back of the display, aligning the mounting holes on the Centris bracket with the mounting holes on the display.



CAUTION: Using screws of improper size may damage your display! Proper screws will easily and completely thread into display mounting holes.

4. Using Phillips screwdriver, install four screws (20) through the mounting holes in Centris bracket into the display (See Figure 12). Tighten all four screws (20). Do not overtighten!

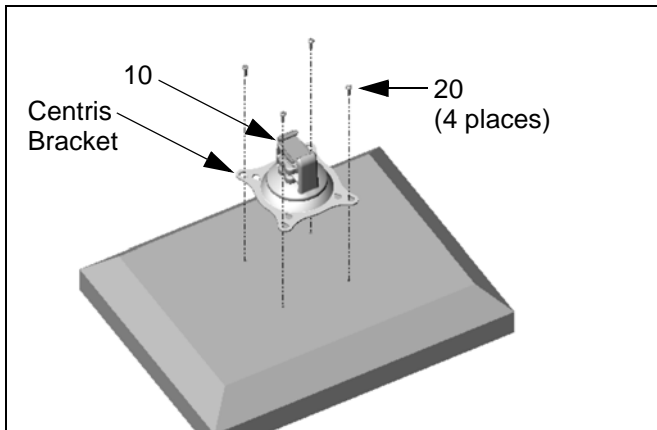

Figure 12: Dual / Triple Display - Flush Mount

5. Proceed to "ARRAY ASSEMBLY."

RECESSED MOUNTING HOLES

1. Verify that you have the following parts:

Item	Description	Qty
10	CENTRIS HEAD, Dual Knob Assembly	2-3

Item	Description	Qty
20	SCREW, Phillips Pan Machine, M4 x 20mm	4 per head
30	SCREW, Phillips Pan Machine, M4 x 30mm	4 per head
40	SPACER, Nylon, 3/8" long	4 per head
50	SPACER, Nylon, 3/4" long	4 per head

2. Carefully place display face down on protective surface.
3. Determine depth of recessed mounting holes relative to back surface of display (against which Centris head dual knob assembly will contact).
4. Select proper length spacer and screw from table below:

NOTE: All spacers used should be the same length. If the recess depths result in multiple spacer lengths, then select the longer spacer.

IF recess DEPTH is:	THEN use spacer:	AND screw:
3/8" or less	40 (3/8" long)	20 (M4 x 20mm)
More than 3/8" up to and including 3/4"	50 (3/4" long)	30 (M4 x 30mm)

5. Place the four selected spacers over each of the mount holes on the back of the display.
6. Place the Centris head (dual knob assembly) onto the spacers, aligning the mounting holes on the Centris bracket with the holes in the spacers (See Figure 13).

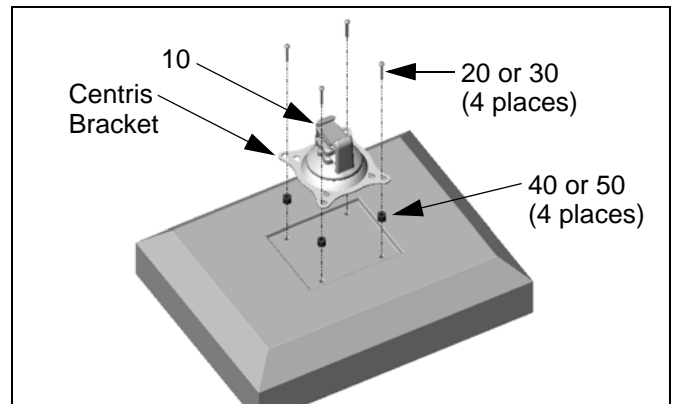

Figure 13: Dual / Triple Display - Recessed Mount



CAUTION: Using screws of improper size may damage your display! Proper screws will easily and completely thread into display mounting holes.

7. Using Phillips screwdriver, install four selected screws through the mounting holes in Centris bracket, through the spacers, into the display (See Figure 13). Tighten all four screws. Do not overtighten!
8. Proceed to "ARRAY ASSEMBLY."

**ARRAY ASSEMBLY
(DUAL / TRIPLE DISPLAY;
FMA-220/-320 ONLY)**

1. Verify that you have the following parts:

Item	Description	Qty
10	ARRAY	1
20	SCREW, Button Head Cap, 5/16"-18 x 4" (Used for Pivot / Swing Arm)	1
30	SCREW, Button Head Cap, 5/16"-18 x 5" (Used with Height Adjustable Arm)	1
40	WASHER, 5/16", UHMW (plastic)	1
50	WASHER, 5/16", Stainless Steel	2
60	PIN	1
70	SPACER, UHMW (plastic)	1
80	NUT, Nylok, 5/16"-18	1
90	SCREW, Button Head Cap, 1/4"-20 x 1/2"	2
100	NUT, Square, Machine Screw, 1/4"-20	2

2. Install pin (60) and spacer (70) into upper mount arm bore (See Figure 14).

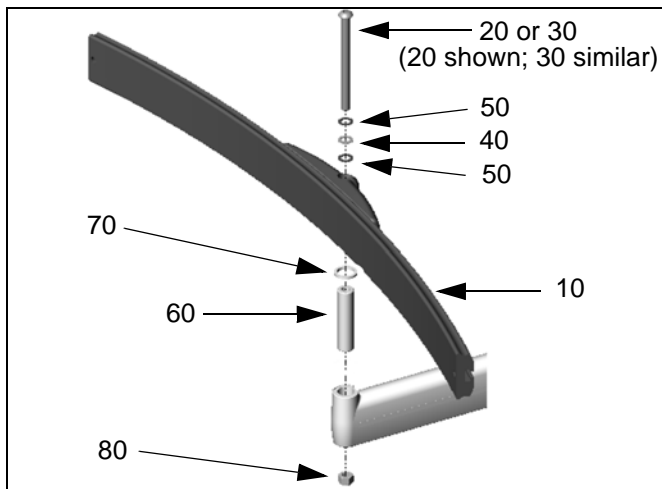

Figure 14: Assemble Array

3. Install array (10) onto pin (60) (See Figure 14).

4. Insert and hold nut (80) into lower mount arm bore (See Figure 14).
5. Insert screw (20 or 30, as applicable) through washer (50), washer (40), washer (50), array (10), array/mount arm assembly, and into nut (80) (See Figure 14). Tighten screw as required using 3/16" hex key.
6. Slide the Centris head (dual knob assembly) onto the array (10) (See Figure 15). Ensure both the top and the bottoms of the Centris head are engaged into the corresponding slots in the array (10).

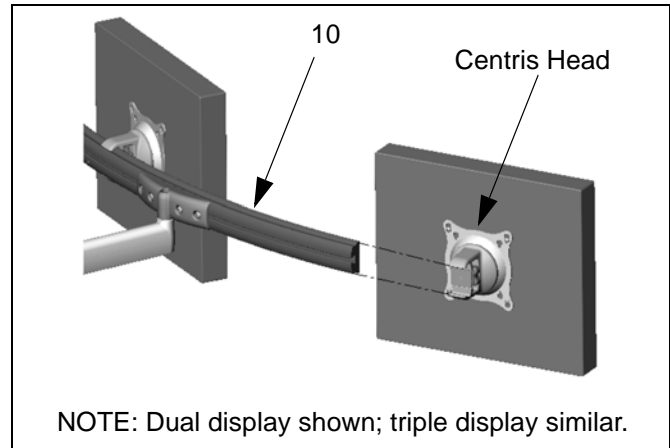

Figure 15: Install Display

7. Position the displays as desired and tighten the Centris head knob closest to the array (10). See "ADJUSTMENT" for additional information.
8. Using 5/32" hex key, install screw (90) and nut (100) on each end of the array (10) to prevent displays from accidentally sliding off (See Figure 16).

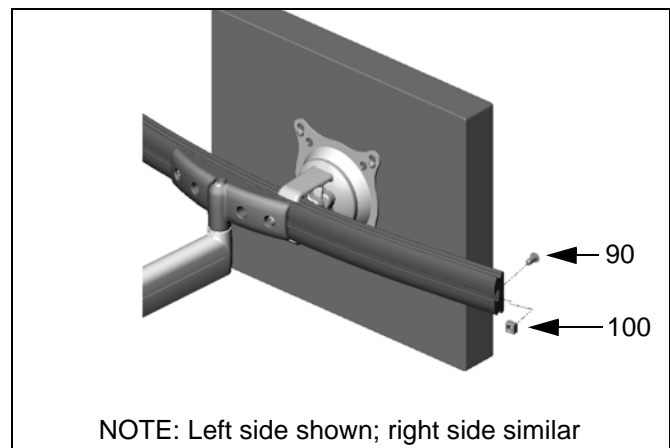

Figure 16: Install End Locks

9. Proceed to "CABLE MANAGEMENT."

**MULTI-DUAL ARM ASSEMBLY
(FCY-210/-220, and FGL-220 ONLY)**

BASIC ASSEMBLY

1. Verify that you have the following parts:

Item	Description	Qty
10	ARM ASSEMBLY, F-Series	2
20	MOUNT, Desk, F-Series	1
30	SCREW, Button Head Cap, 5/16"-18 x 4"	2
40	WASHER, 5/16", UHMW (plastic)	2
50	WASHER, 5/16", Stainless Steel	4
60	PIN	2
70	SPACER, UHMW (plastic)	2
80	WASHER, Lock, External Tooth, 5/8"	4
90	NUT, Nylok, 5/16"-18	2

2. Insert pin (60) into Y-connector upper bore in mount (20) (See Figure 17).

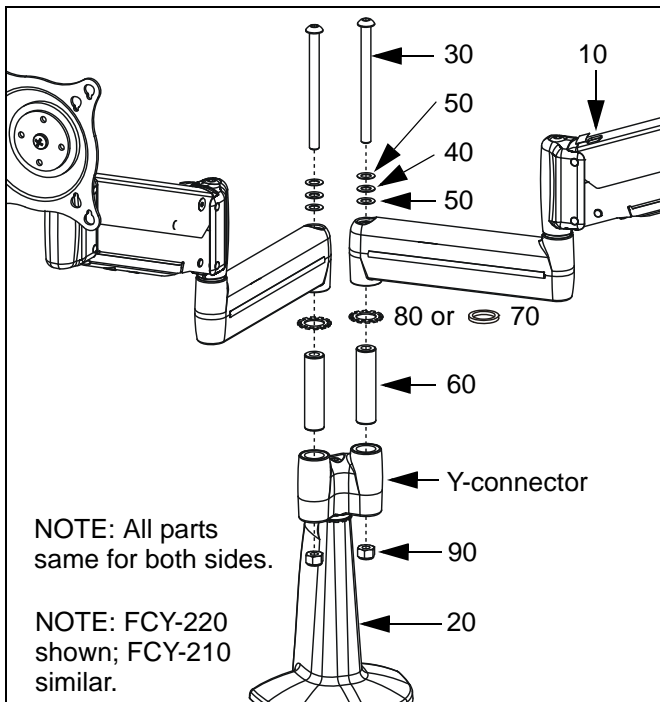

Figure 17: Multi-Dual Arm Assembly

3. Install spacer (70) or washer (80), as desired, on pin (60) (See Figure 17).

NOTE: Spacer (70) will allow limited movement of arm assembly (10) relative to Y-connector, dependent upon tension of screw (30). Washer (80) will lock arm assembly (10) to Y-connector. See "ADJUSTMENT" for detail.

4. Insert arm assembly (10) on pin (60) (See Figure 17).

5. While holding nut (90) in lower bore of Y-connector, insert screw (30) through washer (50), washer (40), washer (50), arm assembly (10), and Y-connector, into nut (90) (See Figure 17). Loosely install screw (30) using 3/16" hex key.



CAUTION: Improper positioning of arm assembly (10) may result in failure of mount and subsequent damage to displays. Do NOT position either arm assembly (10) in gray shaded area.

6. Position arm assembly (10) within UNSHADED area as shown (See Figure 18). Using 3/16" hex key, tighten screw (30) as required to maintain position.

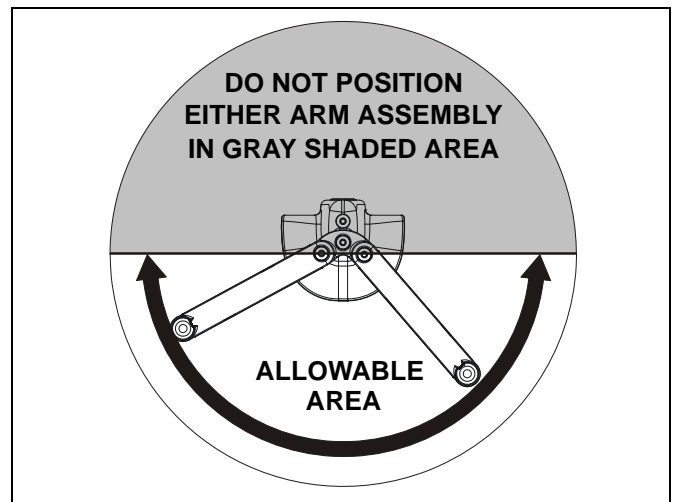

Figure 18: Allowable Arm Area

7. Repeat Steps 2. through 6. for second mount arm assembly (10).

8. If desired, proceed to "MODIFICATION." Otherwise, proceed to:

- "CABLE MANAGEMENT" (for display with RECESSED mounting holes), or to
- "DISPLAY INSTALLATION" (for all other display configurations).

MODIFICATION

If desired, each arm assembly (10) may be modified to prevent movement of the outer arm relative to the inner arm (without loosening the adjustment screw).

NOTE: Spacer (shipped configuration) will allow limited movement of outer arm relative to inner arm, dependent upon tension of screw. Washer (80) will lock arms together. See "ADJUSTMENT" for detail.

1. Using 3/16" hex key, loosen screw until nut can be removed (See Figure 19). Retain nut. Screw and washers may remain in outer arm.

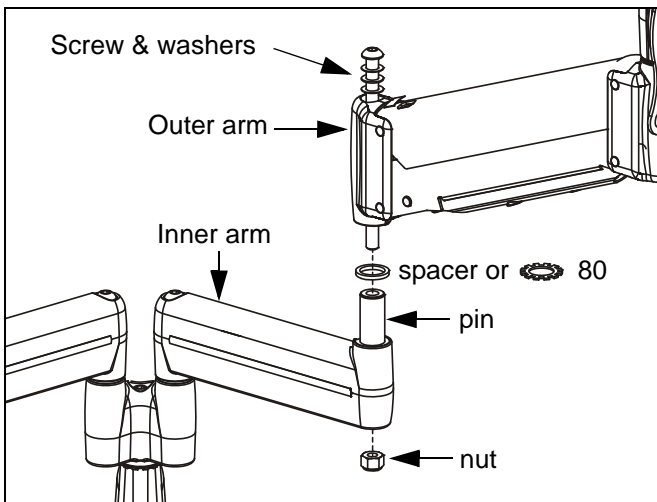

Figure 19: Multi-Dual Arm Modification

2. Lift outer arm from pin (with screw and washers) and place on protective surface.
3. Remove spacer from pin (See Figure 19).
4. Install washer (80) on pin (See Figure 19).
5. Re-install outer arm (with screw and washers) on pin (See Figure 19).
6. Insert and hold nut in lower bore of inner arm (See Figure 19).
7. Tighten screw as required using 3/16" hex key (See Figure 19).
8. Proceed to "CABLE MANAGEMENT" (for display with RECESSED mounting holes), or to "DISPLAY INSTALLATION" (for all other display configurations).

CABLE MANAGEMENT

Item	Description	Qty
10	COVER, Arm	1 per arm
20	SCREW, Phillips Flat Machine, 8-32 x 3/8"	2 per arm
30	WRENCH, Hex, 3/32" (provided)	1

1. Attach all cables to display.
2. Open the cable management bracket by sliding it towards the edge of the arm (See Figure 20).

NOTE: If necessary, cable management bracket attach screws may be loosened using hex key (30).

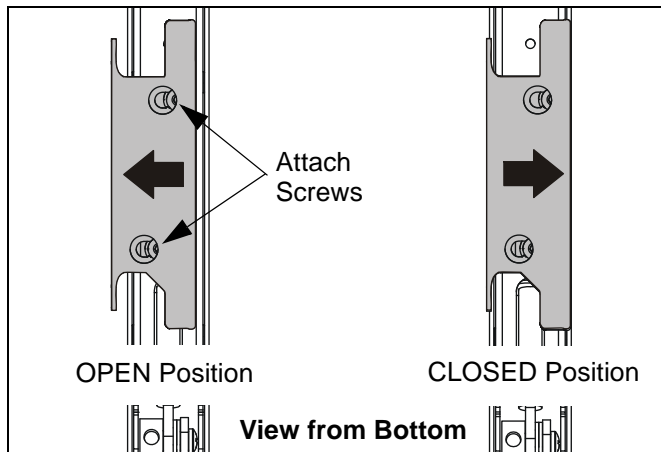

Figure 20: Height Adjustable Arm - Cable Management Bracket



CAUTION: Ensure that adequate cable slack exists for movement of display, and that cables will not be pinched when bracket is closed.

3. Carefully insert cables into bracket (See Figure 21).

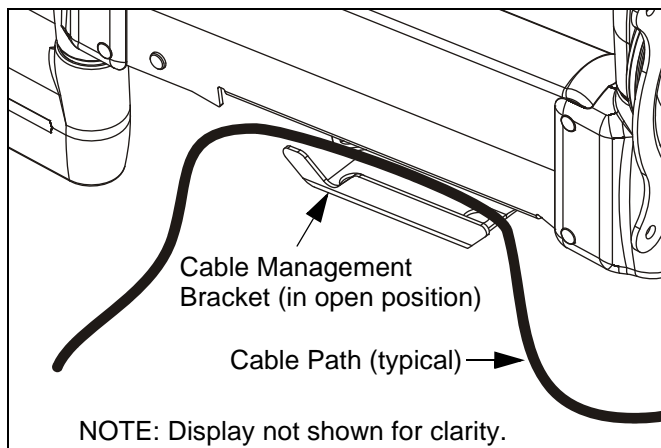

Figure 21: Height Adjustable Arm - Cable Path

4. Close cable management bracket by sliding it back towards the centerline of the arm (See Figure 20).

NOTE: If necessary, cable management bracket attach screws may be tightened using hex key (30).



CAUTION: Ensure that adequate cable slack exists for movement of display, and that cables will not be pinched by installation of cover (10) or screws (20).

5. Carefully insert cables in cavity located in lower portion of mount arm (See Figure 22).
6. Using Phillips screwdriver, install cover (10) with two screws (20).

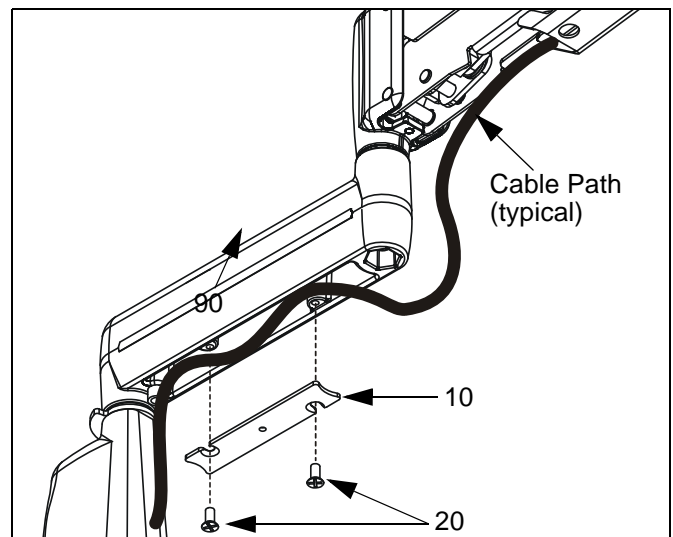

Figure 22: Static Arm - Cable Path

NOTE: Installation is complete.

ADJUSTMENT

ARM

PIVOT / SWING



CAUTION: If washer (80) has been used to assemble FCY-210/-220 arms, then forced movement of arms without loosening screw (30) will damage arm and/or Y-connector (See Figure 17)(See Figure 19).

1. Using 3/16" hex key, slightly loosen or tighten the adjustment screw(s) as necessary (See Figure 23).

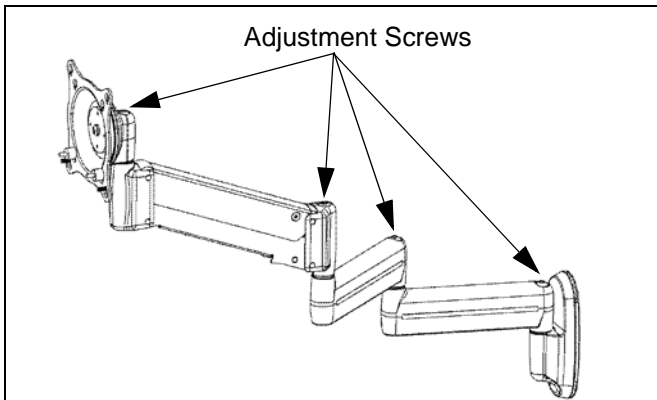

Figure 23: Pivot / Swing Arm Adjustment

HEIGHT ADJUSTABLE (IF APPLICABLE)

1. Using 5/32" hex key, slightly loosen or tighten the adjustment screw as necessary (See Figure 24).
 - If display settles on its own, then rotate adjustment screw counterclockwise (towards the "+" symbol).
 - If display rises on its own, then rotate adjustment screw clockwise (towards the "-" symbol).

NOTE: It may be necessary to raise or lower the height adjustable arm to expose the adjustment screw.

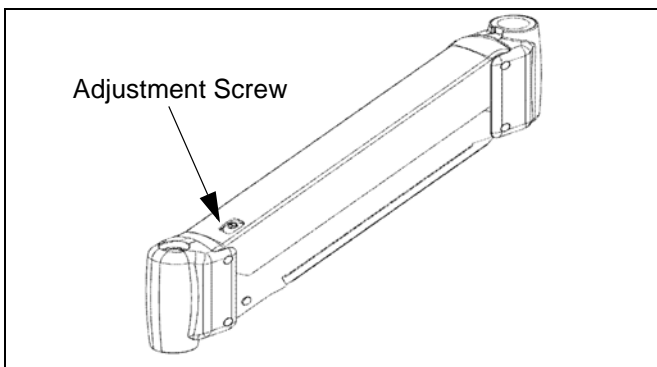

Figure 24: Height Adjustable Arm Adjustment

CENTRIS HEAD

SINGLE DISPLAY AND FCY-210/-220

1. If previously attached, disconnect cables from display, then remove display.
2. Using Phillips screwdriver, slightly loosen or tighten the adjustment screw as necessary (See Figure 25).

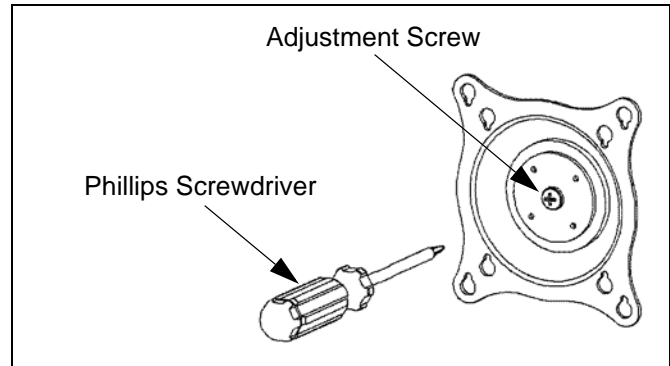

Figure 25: Single Display Adjustment

3. Install mount and then display cables. See "DISPLAY INSTALLATION."

DUAL / TRIPLE DISPLAY (FMA-220/-320 ONLY)

1. LATERAL POSITION ON ARRAY:
 - Using your fingers, slightly loosen adjustment knob "A" (See Figure 26).
 - Slide display to desired position.
 - Using your fingers, tighten adjustment knob "A".

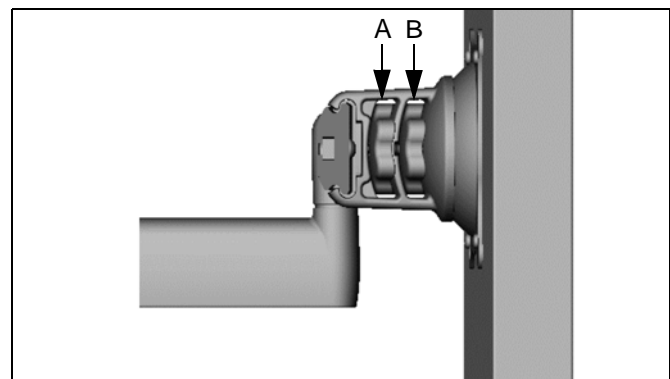

Figure 26: Dual / Triple Display Adjustment

2. PITCH / YAW / ROLL:
 - Using your fingers, slightly loosen adjustment knob "B" (See Figure 26).
 - Adjust display as desired.
 - Using your fingers, tighten adjustment knob "B".



205 Westwood Ave, Long Branch, NJ 07740
Phone: 866-94 BOARDS (26273) / (732)-222-1511
Fax: (732)-222-7088 | E-mail: sales@touchboards.com