

(Shown with SMA602, not included)

FEATURES

- 1 DROP-IN INSTALLATION**
New design fits 2 x 2' (600 x 600 mm) tiles without modification.
- 2 PRECISE POSITIONING**
Vertical projector cradle adjustment and fore/aft projector positioning.
- 3 QUICK CONNECT/DISCONNECT**
Convenient lamp/filter access, maintains registration even when disconnected.
- 4 LOW PROFILE**
Requires 11" (279 mm) clearance above ceiling. Provides 8.25" (210 mm) of downward travel.
- 5 MULTIPLE INSTALLATION OPTIONS**
Mounting options include: Three 0.38" (10 mm) threaded rods, 1-1/2" NPT threaded extension column with SMA602 accessory, and side mounting with built-in joist tabs.

WHAT YOU NEED TO KNOW

UL LISTED

Certified to the latest UL standards

MULTIPLE CONTROL OPTIONS

Choose from single momentary push button, low voltage controller, and internal and external wiring options. Also accepts 5–30V AC/DC for triggering commands. AMX/Crestron control compatibility.

VOLTAGE OPTIONS

120V or 230V (for 230V order the SL151I), current draw of .9 amps

FLEXIBLE INSTALLATION

Independent roll, pitch and yaw

WIRE MORE THAN ONE DEVICE

SPECIFICATIONS

Extension	8.5" (216 mm)
Max Projector Size (HxWxD)	8.38 x 18 x 18.25" (213 x 457 x 464 mm)
Ceiling Opening (HxWxD)	11.25 x 23 x 22.75" (286 x 584 x 578 mm)
Ceiling Closure (WxD)	20.25 x 20.25" (514 x 514 mm)
Roll/Pitch/Yaw	±2°, ±20°, ±5°
Weight Capacity	35 lbs (15.9 kg)
Color	White

RECOMMENDED ACCESSORIES

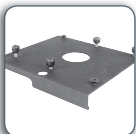

SLB ■ Projector Interface Bracket (required)



IR10 ■ Infrared Remote Control

TECHNICAL DRAWINGS

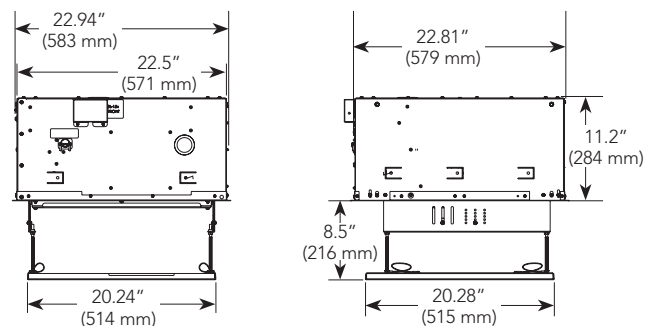

Touchboards

205 Westwood Ave, Long Branch, NJ 07740
Phone: 866-94 BOARDS (26273) / (732)-222-1511
Fax: (732)-222-7088 | E-mail: sales@touchboards.com

For a complete list of automated projector mount accessories see page 27.