



DRANETZ
BMI

User's Guide



DranTech ULTRA

Precision Digital Multimeter

M230H
©2007 Rev. A





- 1 LCD display, see page 3 for description
- 2 MENU/ON|OFF key
*Menu Operating Mode:*Entry acknowledgment (ENTER or ↵)
- 3 AVE/MIN|MAX key for storage of MIN or MAX values, as well as for displaying time since beginning of recording
*Menu Operating Mode:*selection of individual parameters, reverse flux direction, increase values
- 4 MAN|AUTO key for manual measuring range selection
*Menu Operating Mode:*selection of individual parameters, forward flux direction, reduce values
- 5 ESC|FUNC multifunction key
*Menu Operating Mode:*Exit menu level and return to next highest level, exit parameter entry mode without storage of values
- 6 Rotary switch for measurement functions
- 7 Power pack connection jack NA5/600
- 8 Connector jacks

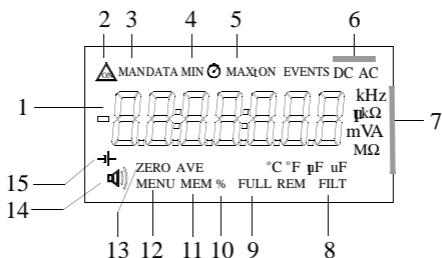

Digital Display Symbols

- 1 Digital display with decimal place and polarity
- 2 Continuous operation
- 3 Manual measuring range selection
- 4 MIN value storage
- 5 MAX value storage
- 6 Selected current and voltage type
- 7 Unit of measure
- 8 Filter active
- 9 Message: measurement value memory is full
- 10 Percentage memory full
- 11 Memory mode active
- 12 Menu operating mode active
- 13 Zero balancing
- 14 Continuity testing activated
- 15 Low battery

Meaning of symbols on the instrument



Warning concerning a point of danger
(Attention: observe documentation)



Ground



Continuous, doubled or reinforced insulation

CAT II

Measuring category II instrument 600 V



Indicates EU conformity

DKD calibration (red label)



Serial number

DKD (German Calibration Service) – calibration

Registration number

Date of calibration (year – month)

Table of Contents

	Page
1	Safety Features and Precautions5
2	Initial Start-Up6
3	Selecting Measuring Functions and Ranges7
3.1	Automatic Measuring Range Selection7
3.2	Manual Measuring Range Selection (Quick Measurements)7
4	Digital Display (LCD)7
5	Minimum and Maximum Value Storage “MIN/MAX” with Time Stamp8
6	Voltage Measurement8
6.1	Zero Balancing (for V, mA , Ω and $^{\circ}\text{C}$)9
6.2	Voltage Measurements for Greater than 600 V9
7	Current Measurement10
8	Resistance Measurement11
8.1	Continuity Testing for Resistance Measurement11
9	Frequency Measurement11
10	Temperature Measurement12
10.1	Temperature Measurement with Pt100 and Pt1000 ..12
10.2	Temperature Measurement with Thermocouple and Reference Junction13
11	Storing Measurement Values to Memory14
12	Setting Operating and Measurement Parameters14
12.1	Description of Measurement Parameters and Memory Commands16
12.2	<i>InFo</i> – Information Menu16
12.3	Default Settings16
13	Data Transmission via RS232 Interface16
13.1	Selecting Interface Parameters17
14	Accessories17
15	Characteristic Values18
16	Maintenance24
16.1	Batteries24
16.2	Power Pack25
16.3	Housing25
17	Multimeter Display Messages25
18	Repair and Replacement Parts Service DKD Calibration Lab and Rental Instrument Service26
19	Warranty27
20	Product Support27

1 Safety Features and Precautions

You have selected an instrument which provides you with a high level of safety.

This instrument fulfills the requirements of the applicable European and national EC guidelines. We confirm this with the CE marking. The relevant declaration of conformity can be obtained from Dranetz-BMI.

The multimeter has been manufactured and tested in accordance with safety regulations IEC/EN 61010-1:2001/VDE 0411-1:2002. When used for its intended purpose, safety of the operator, as well as that of the instrument, is assured. Their safety is however not guaranteed, if the instrument is used improperly or handled carelessly.

In order to maintain flawless technical safety conditions, and to assure safe use, it is imperative that you read the operating instructions thoroughly and carefully before placing your instrument into service, and that you follow all instructions contained therein.

Observe the following safety precautions:

- The instrument may only be operated by persons who are capable of recognizing contact hazards and taking the appropriate safety precautions. Contact hazards exist anywhere, where voltages of greater than 30 V may occur (RMS value).
- Avoid working alone when taking measurements which involve contact hazards. Be certain that a second person is present.
- The maximum allowable voltage between the jacks (8) and earth is 600 V CAT II. Overload capacities are listed in chapter 15.
- Be prepared for the occurrence of unexpected voltages at devices under test (e.g. defective devices). For example, capacitors may be dangerously charged.
- Make certain that the measurement cables are in flawless condition, e.g. no damage to insulation, no interruptions in cables or plugs etc.
- No measurements may be made with this instrument in electrical circuits with corona discharge (high-voltage).
- Special care is required when measurements are made in HF electrical circuits. Dangerous pulsating voltages may be present.
- Measurements under moist ambient conditions are not permissible.
- Be absolutely certain that the measuring ranges are not overloaded beyond their allowable capacities. Limit values can be found in the “Measuring Ranges” table in chapter 15 “Characteristic Values”.
- The current measuring ranges are protected by an internal 250 mA fusible link. A defective fuse can only be replaced by Dranetz-BMI service personnel. The maximum permissible voltage for the measuring current circuit is 600 V AC/DC in the “mA” ranges.
- The instrument may not be used in power installations.

Repair, Parts Replacement and Balancing

When the instrument is opened, voltage conducting parts may be exposed. The instrument must be disconnected from the measuring circuit for repair, replacement of parts or balancing. If repair or balancing of a live, open instrument is required, this may only be carried out by trained personnel who are familiar with the dangers involved.

Errors and Extraordinary Strains

If it may be assumed that the instrument can no longer be operated safely, it must be removed from service and secured against further use.

Safe operation can no longer be relied upon

- if the instrument demonstrates visible damage,
- if the instrument no longer functions,
- after a long period of storage under unfavorable conditions.

2 Initial Start-Up

Batteries

Batteries have already been installed to your instrument, and it is ready for operation. Refer to chapter 16.1, page 24, before placing your instrument into service for the first time, or after it has been in storage!

Switching the Instrument On Manually

⇨ Press the MENU/ON|OFF key.

Activation is acknowledged with a brief acoustic signal. As long as the key remains pressed, all segments of the liquid crystal display (LCD) are active. The LCD is shown on page 3. After the key is released, the instrument is ready for operation.

Note!

Electrical discharge and high frequency interference can cause incorrect displays, and may block the measuring sequence. To reset, switch the instrument off, and then back on. If this procedure is unsuccessful, briefly disconnect the battery from its contact terminals.

Switching the Instrument Off Manually

⇨ Press and hold the MENU/ON|OFF key, until the display is deactivated.

Deactivation of the instrument is acknowledged by two brief acoustic signals.

Automatic Shut-Off

– As battery saving circuit:

Your instrument shuts itself off automatically, if the measurement value remains constant for a long period of time (max. fluctuation $< \pm 400$ digits, 1°C or 1°F per minute), and if none of the keys or the rotary switch are activated for a period of 10 minutes. Deactivation of the instrument is acknowledged by a brief acoustic signal.

Exceptions are as follows:

Transmit or memory mode, and continuous operation.

– If battery voltage drops below the required level:

The battery symbol (⊖) appears approximately 10 minutes before the instrument is shut down. Connect the NA5/600 mains power pack and save data to a PC before replacing the batteries.

Disabling Automatic Shut-Off

The instrument can also be switched to “CONTINUOUS ON”.

⇨ Simultaneously press the ON/MENU/OFF key and the yellow multifunction key when switching the instrument on. The “CONTINUOUS ON” function is indicated at the LCD with the  symbol.

3 Selecting Measuring Functions and Ranges

3.1 Automatic Measuring Range Selection

The multimeter is equipped with automatic measuring range selection. This automatic feature is active as soon as the instrument is switched on, and automatically selects the measuring range which provides optimum resolution.

The voltage measuring range selected in the V AC selector switch position remains active after switching to frequency measurement “Hz”, and automatic measuring range selection is disabled. We thus recommend the selection of a suitable voltage measuring range in the V AC selector switch position before switching to frequency measurement.

The instrument selects the measuring range automatically for the following measured quantities:

Measured Quantity	Resolution	Switching to the Next Highest Range at $\pm(\dots d + 1 d)$	Switching to the Next Lowest Range at $\pm(\dots d - 1 d)$
V $\overline{\text{---}}$, Ω , Hz	6½	1100000	100000
V $\overline{\text{---}}$, mA $\overline{\text{---}}$	5½	—	100000

3.2 Manual Measuring Range Selection (Quick Measurements)

Measurements performed using a suitable fixed measuring range are executed more quickly than those which utilize automatic range selection. Automatic range selection can be deactivated, and ranges can be manually selected according to the following table.

The manual mode is deactivated by pressing and holding the MAN|AUTO key (approx. 1 s), by activating the rotary switch or by switching the instrument off and back on again.

↓ MAN/ AUTO	Function	Acknowledge	
		Dis- play	Acoust. Signal
Brief	Manual Mode Active: selected measuring range is frozen	MAN	1 x
Brief	Switching sequence for: V: 100 mV → 1 V → 10 V → 100 V → 600 V → 100 mV → ... mA: 100 μ A → 1 mA → 10 mA → 100 mA → 100 μ A ... Ω : 100 Ω → 1 k Ω → 10 k Ω → 100 k Ω → 1 M Ω → 10 M Ω ... → 100 Ω	MAN	1 x
Long	Return to Automatic Range Selection	—	2 x

4 Digital Display (LCD)

The measurement value appears at the digital display with correct decimal place and plus or minus sign. The selected unit of measure and the type of current are displayed as well. A minus sign appears in front of the numeric value for the measurement of zero-frequency quantities, if the positive pole of the measured quantity has been connected to the “-V” input.

If the measuring range upper limit of 1,250,000 is exceeded for measured quantities V and mA, “OL” is displayed (overload).

The digital display is refreshed every 0.5 to 2 s (see “Display Update” on page 21).

5 Minimum and Maximum Value Storage “MIN/MAX” with Time Stamp

Minimum and maximum measurement values can be stored to memory with the MIN/MAX function. The most important application for this function is the determination of minimum and maximum values during long-term observation of measurement values. It can be activated for all measuring functions.

- ⇨ Apply the measured quantity to the instrument.
- ⇨ Select the measuring range with MAN|AUTO.
- ⇨ Activate the MIN/MAX function.
- ⇨ Repeated activation of the AVE/MIN|MAX key causes switching amongst:

MAX > t > MIN > t > MAX ...

The measuring ranges can only be selected manually when the “MIN/MAX” function is active.

The “MIN/MAX” function is deactivated, and stored MIN and MAX values are deleted by pressing and holding the MIN/MAX key (approx. 1 s), by activating the rotary switch or by switching the instrument off and back on again.

6 Voltage Measurement

- ⇨ Depending upon the voltage to be measured, set the rotary switch to V \sim or V $\overline{\sim}$.
- ⇨ Connect the measurement cables as shown. The “V” jack should be grounded.

Note!

In the 600 V range, an intermittent acoustic signal sounds alarm if the display value exceeds 600 V.



Attention!

Make absolutely certain that none of the current ranges are active when the multimeter is connected for voltage measurements! If the breaking limit values for the electronic fuse are exceeded due to operator error, both the operator and the instrument are in danger! Simultaneous connection to both current and voltage measuring circuits is prohibited!

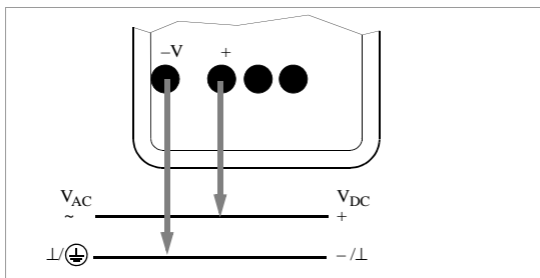

6.1 Zero Balancing (for $V_{\text{---}}$, $mA_{\text{---}}$, Ω and $^{\circ}C$)

- ⇨ Select the desired measuring range with the MAN|AUTO key.
- ⇨ 2-Wire Resistance Measurement, Current Measurement or Temperature Measurement with Pt100 or Pt1000: short-circuit the positive and negative poles of sockets “ $mA\Omega_2$ ” or “ $^{\circ}C_2$ ”, respectively.
- Voltage Measurement, Temperature Measurement with Thermocouple or 4-Wire Resistance Measurement: short-circuit the positive and negative poles of sockets “ $V/^{\circ}C_{TC}$ ” or “ ΩSense ”, respectively.
- ⇨ Briefly press the MAN|AUTO and AVE/MIN|MAX keys simultaneously.

The instrument acknowledges zero balancing with an acoustic signal and “000.0000” (± 1 digit, decimal place depends upon measuring range) and the “ZERO” symbol appear at the LCD. The previously displayed measurement value serves as a reference value (max. ± 30000 digits).

- ⇨ Zero balancing can be deleted:
 - by pressing the MAN|AUTO key after which deletion is acknowledged with an acoustic signal,
 - by selecting a different measuring function
 - or by switching the instrument off.

Note

The zero balancing values (offset) for temperature measurement are stored to memory in the resistance and/or voltage measurement ranges and serve as reference values.

Function	Measuring Range / Function
$^{\circ}C_2$	Pt100: 1 k Ω Ω_2 Pt1000: 10 k Ω Ω_2
$^{\circ}C_4$	Pt100: 1 k Ω Ω_4 Pt1000: 10 k Ω Ω_4
$^{\circ}C_{TC}$	100 mV $V_{\text{---}}$

6.2 Voltage Measurements for Greater than 600 V

Voltages of greater than 600 V can be measured with a high-voltage probe, for example the HV3 or the HV30. The earthing terminal must be connected to ground for measurements of this type. Observe all required safety precautions!

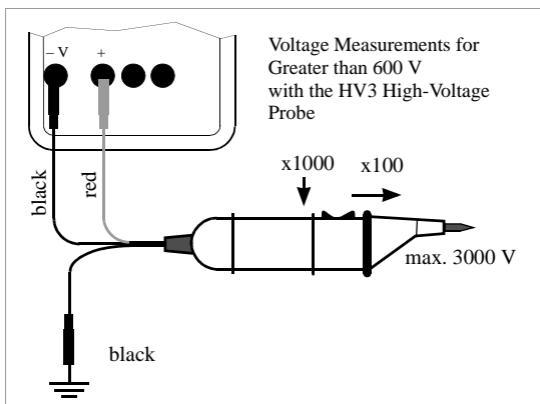

7 Current Measurement

- ⇒ First disconnect supply power to the measuring circuit or the load component, and discharge any capacitors which may be present.
- ⇒ Set the selector switch to “mA”.
After this selection has been made with the rotary switch, the DC current mode is always active.
- ⇒ Select the current type, either “DC” or “AC+DC”, which corresponds to the measured quantity by briefly pressing the multi-function key. Double check for correct current type at the LCD.
- ⇒ Securely connect the instrument to the load component in series as shown (without matching resistor).

Zero Balancing, see chapter 6.1, page 9

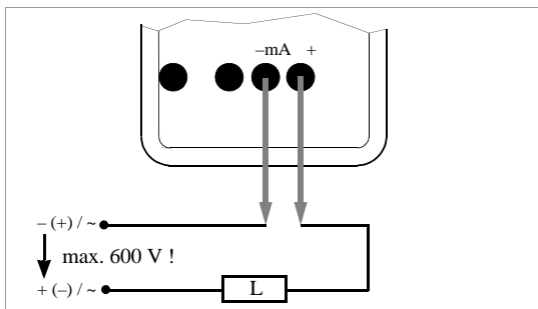

Current Measurement Tips:

- The instrument may not be used in power installations.
- The measuring circuit must be mechanically stable and protected against unintentional interruption. Conductor cross sections and connection points must be substantial enough to avoid excessive overheating.
- In the 100 mA measuring range, an intermittent acoustic signal warns you if the measurement value has exceeded the measuring range upper limit value.
- The current ranges are protected by an internal 250 mA fusible link. A defective fuse can only be replaced by Dranetz-BMI service personnel.

The maximum permissible voltage for the measuring current circuit is 600 V AC/DC in the “mA” ranges.

8 Resistance Measurement

Resistance measurements can be performed for devices with high inductive or capacitive components such as motors, transformers, coils etc.

- ⇒ Be certain that the device under test is voltage-free.
Extraneous voltages distort measurement results!
- ⇒ Set the rotary switch to “ Ω_2 ” (2-wire measurement connection) for the measurement of resistance values greater than 1 k Ω , or to “ Ω_4 ” (4-wire measurement connection) for resistance values within a range of 100 Ω to 1 k Ω
- ⇒ Connect the device under test as shown.

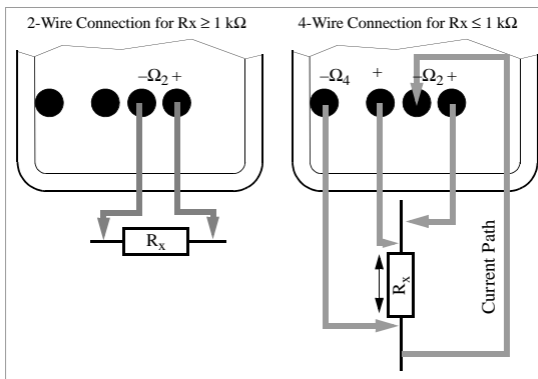

Zero Balancing for the “ Ω_2 ” and “ Ω_4 ” Functions

Cable and transition resistance can be eliminated with zero balancing for measurements of small resistance values.

Zero Balancing, see chapter 6.1, page 9

8.1 Continuity Testing for Resistance Measurement

- ⇒ Set the selector switch to the Ω) position.
- ⇒ Connect the DUT to the “ Ω_2 ” sockets as required for 2-wire resistance measurement.

The continuity test functions within a measuring range of 0 to 100 Ω , and a continuous acoustic signal is generated for values ranging from 0 to 10 Ω

Note!

“O.L” is displayed if the DUT is not connected.

9 Frequency Measurement

- ⇒ Set the selector switch to the $V \approx$ position.
- ⇒ Select the most favorable measuring range.
- ⇒ Now set the selector switch to the Hz position. The selected voltage measuring range remains active.
- ⇒ Apply the measured quantity in the same way as for voltage measurement.

Measurable frequencies and allowable voltages can be found in chapter 15, page 18.

10 Temperature Measurement

10.1 Temperature Measurement with Pt100 and Pt1000

- ⇒ Enter the type of sensor to be used (Pt100 or Pt1000) in the menu mode:
rAtE ▾ SEnSor ↵ Pt 100 △ Pt 1000 ↵
- ⇒ Set the selector switch to
“°C₂” for 2-wire measurement connection or
“°C₄” for 4-wire measurement connection.
- ⇒ Connect the sensor as shown in the following diagram:

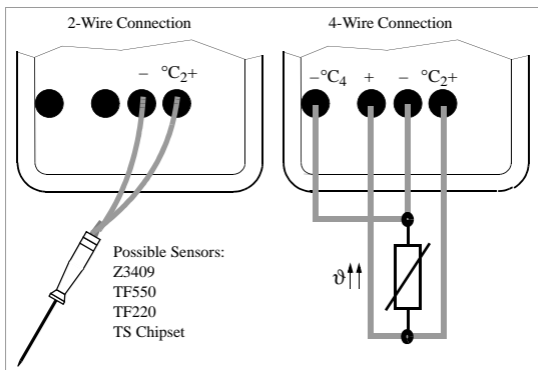

The instrument displays the measured temperature in the unit of measure entered in the menu mode (parameter: “tEMP”).

Compensating for Cable Resistance and Offset

Due to high measuring resolution, compensation must be made for offset and cable resistance in the order indicated below, especially for the 2-wire resistance temperature measuring function (“°C₂”):

– Offset

Any remaining influence caused by the cables and contact resistance can be eliminated by means of zero balancing (see chapter 6.1, page 9).

– Cable Resistance

- *Default setting:* A preset cable resistance value is compensated for when the default setting is used. The preset value is 0.1 Ω which is suitable for temperature sensors available as accessories.
- *Entering a value other than the preset cable resistance value:* (value from data sheet or user calculated, see below):
Enter the utilized sensor type (Pt100 or Pt1000) and the cable resistance value in the “Setup” menu (range: 00.01 to 99.99 Ω):
rAtE ▾ SEnSor ↵ Pt 100 (▾ Pt 1000) ↵
Lr (lead resistance) ↵ XX.XX Ω ▾ △ ↵
- *Calculating cable resistance:*
 - ⇒ Heat or cool the sensor to a known temperature (e.g. 0 °C in ice water), and adjust the value in the Lr menu until the correct measured value is displayed.

- ⇨ Heat or cool the sensor to a known temperature (e.g. 0 °C in ice water), and measure the sensor's resistance with the Ω_2 function using the 1 k Ω range for Pt100 sensors, and the 10 k Ω range for Pt1000 sensors. Cable resistance is equal to the difference between the setpoint (100 Ω from DIN table) and the measured value.

10.2 Temperature Measurement with Thermocouple and Reference Junction

- ⇨ Enter the type of thermocouple to be used (J or K) in the menu mode: rAtE ▾ SEnSor ↵ △ ... J △ K ↵

The reference temperature can either be measured via the internal reference junction, or can be compensated for externally, for example through the use of ice water.

Select sensor type and internal reference temperature:

rAtE ▾ SEnSor ↵ △ ... IntErn ↵

or

Select sensor type and internal reference temperature in °C:

rAtE ▾ SEnSor ↵ △ ... E-tErn ↵

- ⇨ Set the selector switch to "°C_{TC}".

- ⇨ Connect the sensor as shown in the following diagram:

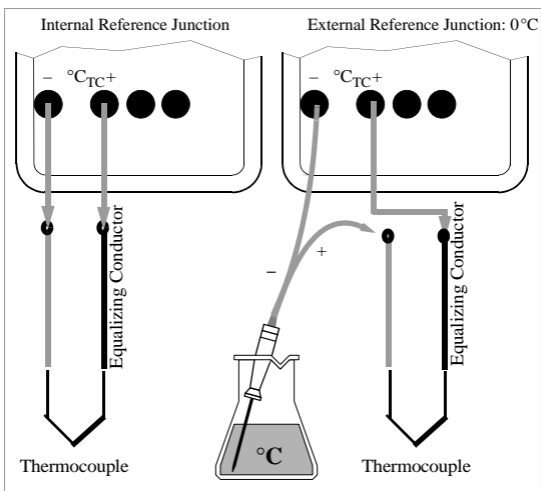

The instrument displays the measured temperature in the unit of measure which has been entered in the menu mode (parameter: "tEMP").

Note!

The internal reference temperature (from the internal reference junction) is measured with a temperature sensor in close proximity to the input jacks. This temperature is somewhat higher than room temperature due to internal warming. The magnitude of this deviation has no effect on measuring accuracy.

11 Storing Measurement Values to Memory

The instrument is equipped with a quartz-movement synchronized measurement-value memory (128 kB), which has sufficient capacity for 30000 measurement values. Data can be stored to intermediate memory, or transmitted directly to a PC.

Memory content can only be read out with the help of a PC, an infrared adapter and DranWin[®] 10 analysis software (see chapter 14, page 17).

Preparations for Memory Mode Operation

- ⇨ Select the desired measuring function, as well as an appropriate measuring range.
- ⇨ If required, connect the mains power pack for long-term measurement value recording.
- ⇨ Select a sampling rate (see chapter 12.1, page 16).

Note!

Sampling rate, measuring function and measuring range cannot be changed during operation in the memory and transmission modes.

Starting Memory Mode Operation via Shortcut

The multimeter must be switched on.

- ⇨ Simultaneously activate the ESC|FUNC and MENU/ON|OFF keys.
MEM,  and MAN appear at the display after a few seconds.

Exiting Memory Mode Operation via Shortcut

- ⇨ Press any key except for MENU/ON|OFF.
- or
- ⇨ Turn the function selector switch.

Memory Occupancy Query

Memory occupancy can be queried from the INFO menu. Occupancy is read out to the display as a percentage (between 000.00(00)% and 100.00(00)%).

Query: rAtE ▾ InFO ↵ △ MEM ↵

Deleting Memory Content



Attention!

The function deletes all stored measurement values.

If FULL appears at the display, no more measurement values can be stored to memory. Stored measurement values should be uploaded and saved to a PC. The memory must be cleared in order to record new measurement values:

rAtE ▾ InFO ↵ △ cLEAR ↵

12 Setting Operating and Measurement Parameters

The menu mode allows for the setting of operating parameters, and the querying of data.

- ⇨ The menu mode is entered by pressing the ↵ key twice if the instrument is switched off, or only once if the instrument is switched on and is in the measuring mode. “MENU” appears in the bottom line of the display.

- ⇒ Repeated activation of the ∇ Δ keys calls up the individual parameters, as well as the “InFo” sub-menu.
- ⇒ After the desired parameter has been selected, the various possible setting can be called up by activating the \downarrow key.
- ⇒ The desired value can be selected by repeatedly activating the ∇ Δ key.
- ⇒ Acknowledge with the \downarrow key and return to operation in the measuring mode.
- ⇒ Entry can be interrupted by pressing the ESC|FUNC key, after which “rAtE” appears at the display. If the ESC|FUNC key is activated once again, the instrument is returned to operation in the measuring mode.
- ⇒ In order to turn the multimeter off, press and hold the \downarrow key until the display goes blank.

Example: “Setting and Activating the Filter”

An interference suppressing filter can be activated for the measurement of current or voltage.

No filter: value = 1, greatest level of filtering: value = 16

rAtE FILt 1 2 4 .

∇ \downarrow Δ Δ \downarrow

or in abbreviated form:

rAtE ∇ FILt \downarrow 1 Δ 2 Δ 4 \downarrow .

Paths to Measuring and Operating Parameters

MENU/
ON|OFF



Menu Mode

Parameter



Settings / Adjustable Values



rAtE	OFF, 10 ms, 100 ms, 1 s, 10 s, 60 s
Addr	1, 2, 3, 4, 5, 6, 7 ... 15
rS 232	9600, 19200
InFo	tEst, uEr, MEM, CLEAR, CALdAtE, CALdUE
SEnSor	Pt 100, Pt 1000, J, K, IntErn, E-tErn
tEMP	°C, °F
FILt	1, 2, 4, 8, 16

12.1 Description of Measurement Parameters and Memory Commands

rAtE – Sampling Rate (storage or measuring rate)

The sampling rate determines the interval, after which the respective measurement values are transmitted to the interface or the measurement value memory.

The following sampling rates are possible:

rAtE ↵ △ OFF, 10 ms, 100 ms, 1 s, 10 s, 60 s.

If OFF is selected, individual measurement values can be stored to memory by simultaneously activating the ESC|FUNC and ↵ keys.

The display is reduced to 5½ places for the 100 ms sampling rate, and to 4½ places for 10 ms.

Addr and *rS232*

See chapter 13.1, page 17.

SEnSor and *tEMP*

See chapter 10, page 12.

FILt – Filter

See above example.

12.2 *InFo* – Information Menu

tESt – RAM Test

Starting the RAM test:

rAtE ▽ InFO ↵ tESt ↵

No other functions may be activated during the RAM test. Two test samples are written to memory, and are subsequently read out. If the test is completed successfully, “Good” appears at the display.

See chapter 17, page 25, for additional display messages.

uEr – Firmware Version

The revision level of the current firmware version is briefly displayed: *rAtE* ▽ InFO ↵ △ *uEr* ↵ 070102.

MEM – Query Memory Occupancy

See description in chapter 11, page 14.

CLEAr – Delete Memory Content

See description in chapter 11, page 14.

CALdAtE – Date of Last Calibration

The date of the last calibration is briefly displayed:

rAtE ▽ InFO ↵ △ CALdAtE ↵ 020399.

CALdUE – Next Recommended Calibration

The due date for the next recommended calibration is briefly displayed: *rAtE* ▽ InFO ↵ △ CALdAtE ↵ 020300.

12.3 Default Settings

Selected parameter settings for ADDR, RS232, CALDATE, CALDUE and VER are retained in the memory after the multimeter is switched off. All other parameter changes are lost, and the default settings are once again active when the instrument is switched back on.

13 Data Transmission via RS232 Interface

The multimeter is equipped with an infrared interface for the transmission of measurement data to a PC. Measurement values are optically transmitted via infrared light through the housing to an interface adapter (accessory), which is plugged into the multimeter. The RS232 interface at the adapter allows for connection to a PC via an interface cable. Furthermore, commands and parameters can be uploaded from the PC to the multimeter.

For example:

- Select and read out measuring parameters
- Select measuring function and range
- Start measurement
- Read out measurement values
(online readout with simultaneous measurement:
shortest possible sampling period is 100 ms)

The interface is always active if the instrument is switched on.

13.1 Selecting Interface Parameters

Addr – Address

If several multimeters, interfaces or memory adapters are connected to the PC, each device requires its own address. Address number 1 should be assigned to the first device, 2 to the second device etc.

rS232 – Baud Rate / Transmission Mode

The baud rate can be selected, and operation in the transmission mode can be simultaneously activated with the rS232 command. Transmission can be interrupted with the MENU/ON|OFF key:
rAtE ▽ rS232 ↵ 9600 △ 19200 ↵.

14 Accessories

BD232 Interface adapter (without memory) allows for remote control of the multimeter, as well as the transmission of measurement data from up to six multimeters to the PC.

DranWin[®]10 Software

DranWin[®]10 software is used to process and display measurement data at a PC. Sampling can be triggered manually with an adjustable sampling interval, or in a signal dependent fashion. Storage of data in ASCII format can be controlled with two trigger thresholds per measuring channel, as well as by means of system time.

The following prerequisites must be fulfilled for the implementation of DranWin[®]10:

Software Requirements:

- MS WINDOWS 95, 98, ME, NT, 2000 or XP.

Hardware Requirements:

- a WINDOWS and IBM compatible PC with at least a Pentium CPU and 32 MB RAM
- a VGA monitor
- a hard disc with at least 20 MB available memory
- a 3.5" floppy disc drive for 1.4 MB floppy discs
- a MICROSOFT compatible mouse
- if you want to print your data: a WINDOWS compatible printer.

15 Characteristic Values

Measuring Function	Measuring Range	Resol. at Meas. Range Upper Limit		
		1 200 000 ¹⁾	120 000 ¹⁾	12 000 ¹⁾
V	100 mV	0.1 μ V	1 μ V	10 μ V
	1 V	1 μ V	10 μ V	100 μ V
	10 V	10 μ V	100 μ V	1 mV
	100 V	100 μ V	1 mV	10 mV
	600 V	1 mV	10 mV	100 mV
mA	100 μ A	100 pA	1 nA	10 nA
	1 mA	1 nA	10 nA	100 nA
	10 mA	10 nA	100 nA	1 μ A
	100 mA	100 nA	1 μ A	10 μ A
Ω	100 Ω	0.1 m Ω	1 m Ω	10 m Ω
	1 k Ω	1 m Ω	10 m Ω	100 m Ω
	10 k Ω	10 m Ω	100 m Ω	1 Ω
	100 k Ω	0.1 Ω	1 Ω	10 Ω
	1 M Ω	1 Ω	10 Ω	100 Ω
	10 M Ω	10 Ω	100 Ω	1000 Ω
Ω \square)	100 Ω			10 m Ω
		Resolution		
Hz	1 Hz ²⁾ to 100 kHz	0.000 001 Hz		
		0.1 Hz		
			Sensor	
$^{\circ}$C/$^{\circ}$F	- 200.0 ... + 850.0 $^{\circ}$ C	0.01 $^{\circ}$ C		Pt100 / Pt1000
	- 210.0 ... + 1200.0 $^{\circ}$ C	0.1 $^{\circ}$ C		J (Fe-CuNi)
	- 270.0 ... + 1372.0 $^{\circ}$ C			K (NiCr-Ni)
		Input Impedance		
		\equiv	\approx	
V	100 mV	> 1 G Ω	> 1 G Ω // < 50 pF	
	1 V	> 1 G Ω	10 M Ω // < 50 pF	
	10 V	10 M Ω	10 M Ω // < 50 pF	
	100 V	10 M Ω	10 M Ω // < 50 pF	
	600 V	10 M Ω	10 M Ω // < 50 pF	
		Approx. Voltage Drop at Meas. Range Upper Limit		
		\equiv	\approx	
mA	100 μ A	150 mV	150 mV	
	1 mA	1.5 V	1.5 V	
	10 mA	150 mV	150 mV	
	100 mA	1.5 V	1.5 V	
		Open-Circuit Voltage	Meas. Current at Meas. Range Upper Limit	
Ω	100 Ω	3 V	1 mA	
	1 k Ω	3 V	1 mA	
	10 k Ω	3 V	100 μ A	
	100 k Ω	3 V	10 μ A	
	1 M Ω	3 V	1 μ A	
	10 M Ω	3 V	100 nA	
Ω \square)	100 Ω	3 V	1 mA	

Measuring Range	Inherent Deviation at max. Resolution at Reference Conditions $\pm(\dots\% \text{ of rdg.} + \% \text{ of range})$		Frequency Range in Hz	Overload Capacity ³⁾	
	\equiv	\approx ^{4) 5)}		Value	Duration
100mV	0.005 + 0.0006 ⁶⁾	0.08 + 0.06 ⁷⁾	45 ... 65	600 V _{eff} sine	continuous
		0.1 + 0.1	10 ... 1 k		
		5 + 0.5	1 k ... 5 k		
1 V	0.0030 + 0.0004	0.08 + 0.06 ⁷⁾	45 ... 65		
		0.1 + 0.1	10 ... 1 k		
		0.2 + 0.1	1 k ... 10 k		
		5 + 0.5	10 k ... 50 k		
10 V	0.0030 + 0.0004	0.08 + 0.06	45 ... 65		
		0.1 + 0.1	10 ... 1 k		
		0.2 + 0.1	1 k ... 10 k		
100 V	0.0030 + 0.0006	1 + 0.1	10 k ... 50 k		
		3 + 0.1	50 k ... 100 k		
600 V	0.0040 + 0.0010	0.08 + 0.06	45 ... 65		
		0.2 + 0.1	10 ... 1 k		
		3 + 0.1	1 k ... 10 k		
	\equiv	\approx ^{4) 5)}			
100 μ A	0.02 + 0.002	0.08 + 0.06	45 ... 65	0.18 A/ 600 V _{eff}	continuous
1mA		0.1 + 0.1	10 ... 1 k		
10mA		0.2 + 0.1	1 k ... 5 k		
100mA					
	$\pm(\dots\% \text{ of rdg.} + \% \text{ of range})$				
100 Ω	0.005 + 0.001 ⁶⁾			600 V _{eff} sine	10 min
1 k Ω	0.005 + 0.001 ⁶⁾				
10 k Ω	0.005 + 0.001				
100 k Ω	0.005 + 0.001				
1M Ω	0.05 + 0.002				
10M Ω	0.5 + 0.02				
Ω \approx)	0.05 + 0.01				
1 Hz to 100 kHz	0.05 % of rdg.			600 V	continuous
Pt 100/ Pt 1000	-200.0 ... +850.0 °C	$\pm(0.05\% \text{ of rdg.} + 0.08 \text{ K})$ ⁸⁾		600 V _{eff} sine	10 min
J	-210.0 ... +1200.0 °C	$\pm(0.7\% \text{ of rdg.} + 0.3 \text{ K})$ ⁸⁾		600 V _{eff} sine	.
K	-270.0 ... +1372.0 °C				

- 1) Number of display places: 6½ for DC and Ω , 5½ for AC
Resolution is adjustable for the storage and the transmission of measurement values (see chapter 12.1).
- 2) Lowest measurable frequency for sinusoidal measurement signals, combined measurement of period duration and frequency
- 3) At 0 ° ... +40 ° C
- 4) As of 10% of the measuring range. See page 20 for influences.
- 5) DC component: max. 10% of reading.
- 6) ZERO is displayed when the "Zero Balancing" function is active.
- 7) Range 100 mV \approx : $U_E = 10 \dots 30 \text{ mV}_{\text{eff}}$ additional error: +0.5% range
1 V \approx : $U_E = 0.1 \dots 0.3 \text{ V}_{\text{eff}}$ additional error: +0.3% range
- 8) Plus sensor deviation

Influence Variables and Effects

Influence Variable	Influence Range	Measured Quantity / Measuring Range ¹⁾	Influence Effect ppm/K
Temperature	0 °C ... +21 °C and +25 °C ... +40 °C	V $\overline{=}$	8
		V $\overline{\approx}$	100
		mA $\overline{=}$	20
		mA $\overline{\approx}$	100
		100 Ω ... 100 k Ω	8
		1 M Ω	15
		10 M Ω	100
		Hz	50
		°C	15

Influence Variable	Influence Range	Measured Quantity / Measuring Range ¹⁾	Influence Effect ³⁾
Measurement Quantity Waveform	Crest factor CF	V \sim , mA	1 ... 3
			> 3 ... 5
			10
	<p>The allowable crest factor (CF) for the periodic quantity to be measured is dependent upon the displayed value:</p> <p>Voltage and Current Measure-</p>		

Influence Variable	Influence Range	Measured Quantity / Measuring Range ¹⁾	Influence Effect
Relative Humidity	75% 3 days device off	V, mA, Ω Hz °C	1 x inherent deviation

Influence Variable	Influence Range	Measuring Range	Damping \pm dB
Common-Mode Interference Voltage	Interference quantity max. 600 V \sim 50 Hz, 60 Hz sine	V $\overline{=}$	> 90 dB
		100 mV ... 10 V \sim	> 80 dB
		100 V \sim	> 70 dB
		600 V \sim	> 60 dB
Series-Mode Interference Voltage	Interference quantity V \sim , respective measuring range nominal value, max. 600 V \sim , 50 Hz, 60 Hz sine	V $\overline{=}$	> 60 dB
		V \sim	> 60 dB

¹⁾ With zero balancing

²⁾ Inherent deviation values valid as of a display value of at least 10% of the measuring range.

³⁾ Except for sinusoidal waveform

Reference Conditions

Ambient

Temperature	+23° C ±2 K
Relative Humidity	40 ... 60%
Measurement	
Quantity Frequency	45 ... 65 Hz
Measurement	
Quantity Waveform	sine
Battery Voltage	3 V ±0.1 V
Power Pack Voltage	5 V ±0.2 V

Response Time

After Manual Range Selection at max. Resolution

Measured Quantity / Measuring Range	Response Time	Measured Quantity Step Function
V $\overline{\sim}$, V \sim , A $\overline{\sim}$, A \sim	max. 2 s	from 0 to 80% of measuring range upper limit
100 Ω ... 1 M Ω	max. 2 s	from ∞ to 50% of measuring range upper limit
10 M Ω	max. 5 s	
Continuity	< 30 ms	
°C (Pt100)	max. 2 s	from 0 to 50% of measuring range upper limit
>10 Hz	max. 2 s	

Measuring Cycle

Measuring Function	Interval Depending upon Resolution		
	1 200 000	120 000	12 000
V $\overline{\sim}$, mA $\overline{\sim}$	1 s	0.1 s	0.01 s
V \sim , mA \sim	—	0.1 s	0.01 s
Ω / °C	1 s	0.1 s	0.01 s
°C (K, J)	1 s	0.1 s	0.01 s
Hz	1 s (\leq 2 s at 1 Hz)	—	—

Display

LCD field (65 mm x 30 mm) with digital display, including display of unit of measure, current type and various special functions.

Type / Char. Height	7 segment / 12 mm
Number of Places	6½
Overload Display	“OL” is displayed as of 1 250 000 digits
Polarity Display	“-” sign is displayed when plus pole is connected to “-V”
Display Update	
V, mA, Ω , °C/°F	once per second
Hz	1 to 0.5 times per second

Power Supply

Batteries

2 ea. 1.5 V mignon cells
alkaline manganese cells per IEC LR6

Service Life

Measuring Function (with 2.5 Ah alkaline manganese cells)	Power Consumption in mA	Service Life in Hours
V DC, mA DC, °C/°F	100	16
V (AC + DC), mA (AC + DC)	105	15
Transmission mode, sampling rate: 100 ms		
9600 baud	114	
19200 baud	108	
Transmission mode, sampling rate: 10 ms		
9600 baud	156	
19200 baud	146	

Battery Test

Automatic display of “” when battery voltage falls to below approx. 2.3 V.

Battery Saver Circuit

The instrument switches itself off automatically if the measurement value remains unchanged for about 10 minutes, and if none of the operating elements are activated during this time. This function is disabled in the transmission and menu modes, or if “continuous on” has been activated.

Fuses

The current measuring ranges are protected by an internal 250 mA fusible link. A defective fuse can only be replaced by Dranetz-BMI service personnel.

The voltage of the measuring current circuit may not exceed $600 V_{\text{eff}}$.

Electrical Safety

Protection Class

II per IEC/EN 61010-1:2001
/VDE 0411-1:2002

Measuring Category

II

Operating Voltage

600 V

Contamination Level

2

Test Voltage

3.7 kV~ per IEC/EN 61010-1:2001
/VDE 0411-1:2002

Electromagnetic Compatibility (EMC)

Interference Emission

EN 61326:2002 class B

Interference Immunity

EN 61326:2002

IEC 61000-4-2:1995/A1:1998

Feature A

8 kV atmospheric discharge

4 kV contact discharge

IEC 61000-4-3:1995/A1:1998

Feature B

3 V/m

Ambient Conditions	
Operating Temp.	– 5° C ... +50° C
Storage Temperature	–25° C ... +70° C (without batteries)
Relative Humidity	max. 75%, no condensation allowed
Elevation	to 2000 m
Deployment	indoors, outdoors: only in the specified ambient conditions
Warm-Up Time	5 min.
Mechanical Design	
Protection	instrument: IP 50, connector jacks: IP 20
Dimensions	84 mm x 195 mm x 35 mm
Weight	approx. 350 gr. with batteries
Data Interface	
Data Transmission	optical with infrared light, through the housing (patented)
<i>With interface adapter as accessory</i>	
Type	RS232C, serial, per DIN 19241
Baud Rate	
Bidirectional	BD232: 9600 baud



Attention!

Disconnect the instrument from the measuring circuit before opening to replace batteries!

16.1 Batteries

Note!

Battery Replacement

Stored measurement values are deleted when the battery is replaced. We recommend connecting the power pack, or uploading data to a PC with the help of DranWin[®]10 software, before replacing batteries in order to prevent data loss. Operating parameters remain in memory.

Before initial start-up, or after storage of your instrument, make sure that no leakage has occurred at the instrument battery. Repeat this inspection at regular intervals.

If battery leakage has occurred, electrolyte from the battery must be carefully and completely removed with a damp cloth, and a new battery must be installed.

If the “” symbol appears at the LCD, you should replace the batteries as soon as possible. You can continue to take measurements, but reduced measuring accuracy may result.

The instrument works with two 1.5 V batteries per IEC R6 or IEC LR6, or with corresponding, rechargeable NiCd batteries.

Battery Replacement

- ⇨ Lay the instrument onto a flat surface with the front panel facing down, loosen the two screws at the back and lift out the housing base starting at point (a).
- ⇨ Remove the batteries from the battery compartment.
- ⇨ Insert two 1.5 V mignon cells into the battery compartment in the direction indicated by the polarity symbols.
- ⇨ Important for reassembly: First set the housing base onto the housing top and align accurately (see photo below). Then press the two housing halves together, first at the bottom front (a), and then at the top front (b).



- ⇨ Retighten the housing base with the two screws.
- ⇨ Please dispose of depleted batteries properly!

16.2 Power Pack

Use only the N5/600 power pack for power supply to your instrument. The highly insulated cable assures safety for the operator, and the power pack provides for reliable electrical isolation. When a mains power pack is used, the batteries inside the instrument are disconnected automatically.

Country	Type	Article No.
Germany	NA5/600	Z218F

Note!

We recommend that zero balancing be performed in accordance with chapter 6.1, page 9, if the power pack is used.

16.3 Housing

No special maintenance is required for the housing. Keep outside surfaces clean. Use a slightly dampened cloth for cleaning. Avoid the use of cleansers, abrasives or solvents.

17 Multimeter Display Messages

Message	Function	Significance
FAIL	RAM test	RAM test failed *
Good	RAM test	RAM test successfully completed
+	all operating modes	battery voltage has dropped to below 2.3 V
FULL	transmission mode	measurement value memory is full
OL	measuring	indicates overload

* A hardware problem may have occurred. Please send your multimeter to our Repair and Replacement Parts Service department.

18 **Repair and Replacement Parts Service DKD Calibration Lab * and Rental Instrument Service**

If required please contact:

Dranetz-BMI
1000 New Durham Road
Edison, NJ 08818-4019 USA
Phone: 1-800-372-6832 or 732-287-3680
Fax: 732-248-1834
www.dranetz-bmi.com

This address is only valid in the United States. Please contact our representatives or subsidiaries for service in other countries.

* **DKD** Calibration Laboratory for Electrical Quantities
DKD-K-19701 accredited per DIN EN ISO/IEC 17025

Accredited measured quantities: direct voltage, direct current values, DC resistance, alternating voltage, alternating current values, AC active power, AC apparent power, DC power, capacitance and frequency

Competent Partner

GOSSEN METRAWATT GMBH is certified per
DIN EN ISO 9001:2000.

Our DKD Calibration Laboratory has been accredited in accordance with DIN EN ISO/IEC 17025 by the Physikalisch Technische Bundesanstalt (*Federal Institute for Physics and Technology*) and the Deutsche Kalibrierdienst (*German Calibration Service*) under registration number DKD-K-19701.

Our competence in the field of metrology covers test reports, proprietary calibration certificates and DKD calibration certificates.

Our range of services is complemented by a Test Equipment Management service which is provided free of charge.

An on-site DKD calibration station is an integral part of our service department. If any faults are detected during calibration, our specialists are able to carry out the necessary repairs with original replacement parts.

Needless to say, in our function as calibration laboratory, we calibrate all instruments, irrespective of the manufacturer.

19 Warranty

The warranty period for all DranTech measuring and calibration instruments is 3 years after date of shipment. Calibration is guaranteed for a period of 12 months. The guarantee covers materials and workmanship. Damage resulting from use for any other than the intended purpose as well as any and all resultant costs are excluded.

20 Product Support

If required please contact:

Dranetz-BMI
1000 New Durham Road
Edison, NJ 08818-4019 USA
Phone: 1-800-372-6832 or 732-287-3680
Fax: 732-248-1834
www.dranetz-bmi.com

DKD Calibration Certificate Reprints

If you need to order a reprint of the DKD calibration certificate for your instrument, please include the ID number shown in the uppermost and lowermost fields of the red calibration seal. We do not need the instrument's serial number.



Edited in United States • Subject to change without notice • A pdf version is available on the internet

Dranetz-BMI
1000 New Durham Road
Edison, New Jersey 08818-4019 • USA
Phone 1-800-372-6832 or 732-287-3680
Fax 732-248-1834
www.dranetz-bmi.com

