

AM RADIO KIT

MODEL AM-550CK DUAL AUDIO SUPERHET INTEGRATED CIRCUIT, 7 TRANSISTORS, 2 DIODES



7 56619 00843 1

TEquipment  USA
.NET
An Interworld Highway, LLC Company

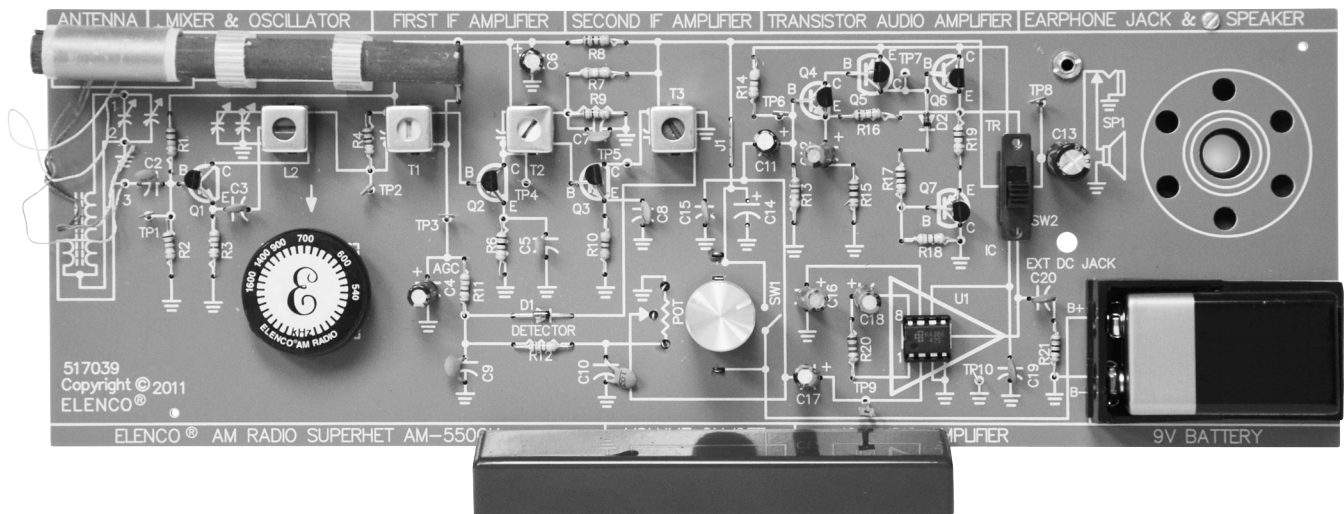

Assembly and Instruction Manual

ELENCO®

PARTS LIST

If you are a student, and any parts are missing or damaged, please see instructor or bookstore. If you purchased this AM radio kit from a distributor, catalog, etc., please contact ELENCO® (address/phone/e-mail is at the back of this manual) for additional assistance, if needed. **DO NOT** contact your place of purchase as they will not be able to help you.

RESISTORS (see page 3 "Identifying Resistor Values")

Qty.	Symbol	Value	Color Code	Part #
<input type="checkbox"/> 1	R19	1Ω 1/4W 5%	brown-black-gold-gold	111000
<input type="checkbox"/> 1	R21	10Ω 1/4W 5%	brown-black-black-gold	121000
<input type="checkbox"/> 3	R8, R15, R17	100Ω 1/4W 5%	brown-black-brown-gold	131000
<input type="checkbox"/> 1	R10	470Ω 1/4W 5%	yellow-violet-brown-gold	134700
<input type="checkbox"/> 1	R18	820Ω 1/4W 5%	gray-red-brown-gold	138200
<input type="checkbox"/> 2	R6, R16	1kΩ 1/4W 5%	brown-black-red-gold	141000
<input type="checkbox"/> 1	R20	1.2kΩ 1/4W 5%	brown-red-red-gold	141200
<input type="checkbox"/> 1	R12	2.2kΩ 1/4W 5%	red-red-red-gold	142200
<input type="checkbox"/> 2	R3, R11	3.3kΩ 1/4W 5%	orange-orange-red-gold	143300
<input type="checkbox"/> 1	R9	10kΩ 1/4W 5%	brown-black-orange-gold	151000
<input type="checkbox"/> 1	R2	12kΩ 1/4W 5%	brown-red-orange-gold	151200
<input type="checkbox"/> 1	R5	27kΩ 1/4W 5%	red-violet-orange-gold	152700
<input type="checkbox"/> 1	R7	39kΩ 1/4W 5%	orange-white-orange-gold	153900
<input type="checkbox"/> 1	R14	47kΩ 1/4W 5%	yellow-violet-orange-gold	154700
<input type="checkbox"/> 1	R1	56kΩ 1/4W 5%	green-blue-orange-gold	155600
<input type="checkbox"/> 1	R13	82kΩ 1/4W 5%	gray-red-orange-gold	158200
<input type="checkbox"/> 1	R4	1MΩ 1/4W 5%	brown-black-green-gold	171000
<input type="checkbox"/> 1	Pot/SW1	50kΩ / SW	Pot/SW with nut and washer	192522

CAPACITORS (see page 3 "Identifying Capacitor Values")

Qty.	Symbol	Value	Description	Part #
<input type="checkbox"/> 1	C1	Variable	Tuning	211677
<input type="checkbox"/> 1	C15	0.001μF	Discap (102)	231036
<input type="checkbox"/> 2	C3, C10	0.01μF	Discap (103)	241031
<input type="checkbox"/> 5	C2, C5, C7, C8, C9	0.02μF or 0.022μF	Discap (203) or (223)	242010
<input type="checkbox"/> 1	C20	0.047μF	Discap (473)	244780
<input type="checkbox"/> 1	C19	0.1μF	Discap (104)	
<input type="checkbox"/> 5	C4,C11,C16,C17,C18	10μF	Electrolytic (Lytic)	271045
<input type="checkbox"/> 1	C12	47μF	Electrolytic (Lytic)	274744
<input type="checkbox"/> 1	C6	100μF	Electrolytic (Lytic)	281044
<input type="checkbox"/> 2	C13, C14	470μF	Electrolytic (Lytic)	284744

SEMICONDUCTORS

Qty.	Symbol	Description	Part #
<input type="checkbox"/> 2	D1, D2	1N4148 Diode	314148
<input type="checkbox"/> 4	Q1, Q2, Q3, Q4	2N3904 Transistor NPN	323904
<input type="checkbox"/> 1	Q5	2N3906 Transistor PNP	323906
<input type="checkbox"/> 1	Q6	MPS8050 or 6560 Transistor NPN	328050
<input type="checkbox"/> 1	Q7	MPS8550 or 6562 Transistor PNP	328550
<input type="checkbox"/> 1	U1	LM386 Integrated circuit	330386

COILS

Qty.	Symbol	Value	Description	Part #
<input type="checkbox"/> 1	L2	Oscillator	(red dot)	430057
<input type="checkbox"/> 1	T1	IF	(yellow dot)	430260
<input type="checkbox"/> 1	T2	IF	(white dot)	430262
<input type="checkbox"/> 1	T3	Detector	(black dot)	430264
<input type="checkbox"/> 1	L1	AM Antenna with holders		484004

MISCELLANEOUS

Qty.	Description	Part #	Qty.	Description	Part #
<input type="checkbox"/> 1	PC board	517039	<input type="checkbox"/> 1	Screw M2.5 x 7.5mm (gang)	641107
<input type="checkbox"/> 1	Switch	541023	<input type="checkbox"/> 2	Screw 2.5 x 3.8mm (gang)	641310
<input type="checkbox"/> 1	Battery holder	590096	<input type="checkbox"/> 4	Nut M1.8	644210
<input type="checkbox"/> 1	Speaker	590102	<input type="checkbox"/> 1	Socket 8-pin	664008
<input type="checkbox"/> 1	Knob (dial)	622040	<input type="checkbox"/> 10	Test point pin	665008
<input type="checkbox"/> 1	Knob (pot)	622050	<input type="checkbox"/> 1	Label, dial knob	720422
<input type="checkbox"/> 1	Earphone jack with nut	622130 or 622131	<input type="checkbox"/> 1	Speaker pad	780128
<input type="checkbox"/> 1	Radio stand	626100	<input type="checkbox"/> 1	Wire 4"	814920
<input type="checkbox"/> 1	Earphone	629250	<input type="checkbox"/> 1	Solder lead-free	9LF99
<input type="checkbox"/> 4	Screw M1.8 x 7.5mm (battery holder)	641100			

**** SAVE THE BOX THAT THIS KIT CAME IN. IT WILL BE USED ON PAGES 29 AND 34. ****

PARTS IDENTIFICATION

RESISTORS



Resistor

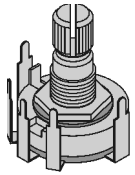

50kΩ
Potentiometer/
Switch
with Nut and
Washer

CAPACITORS

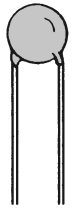

Discap



Electrolytic
Radial

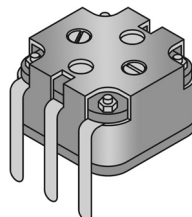

Tuning

SEMICONDUCTORS



Diode

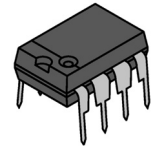

LM386 IC

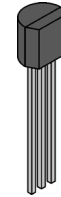

Transistor

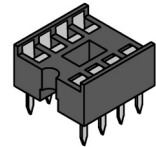

8-pin Socket

Color Dot

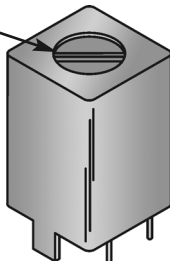

Coil

COILS

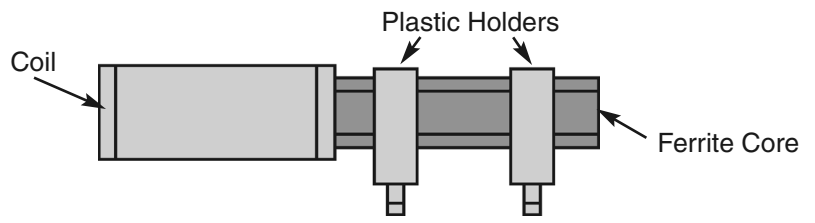

Antenna Assembly

MISCELLANEOUS

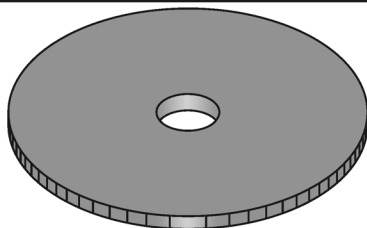

Knob (dial)

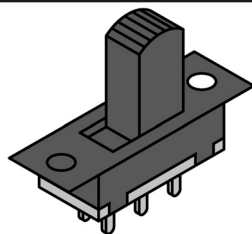

Slide Switch

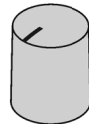

Knob (pot)

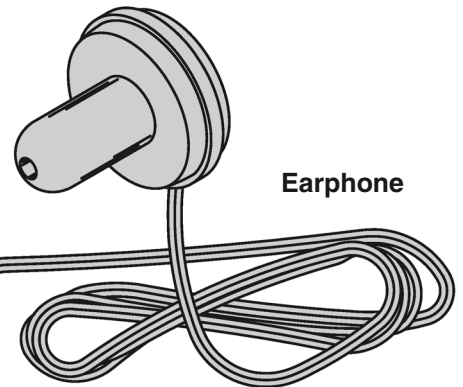

Earphone

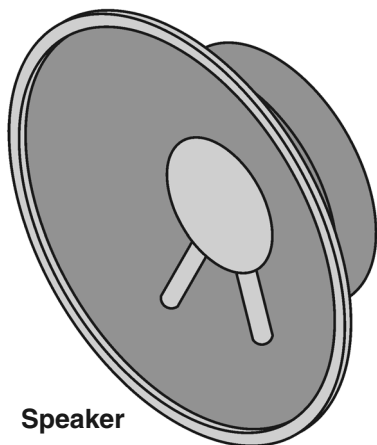

Speaker

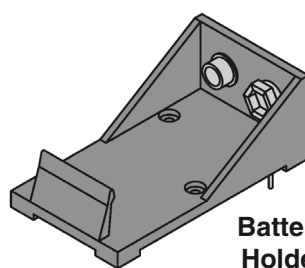

Battery
Holder

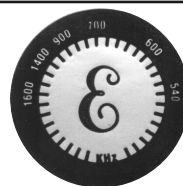

Label

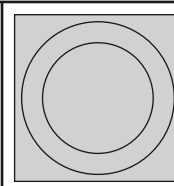

Speaker Pad

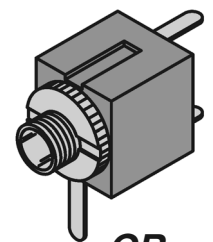

OR



Test Point Pin

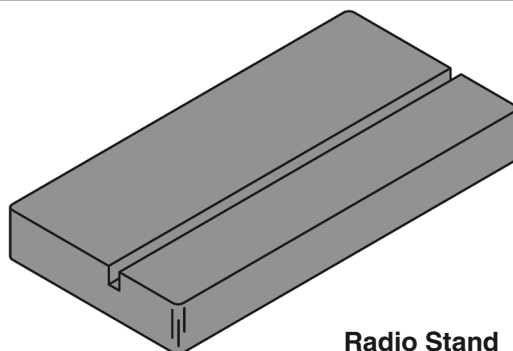

Radio Stand

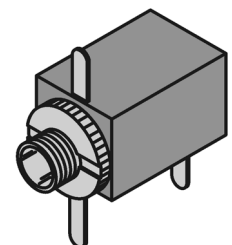

Earphone Jack
with Nut

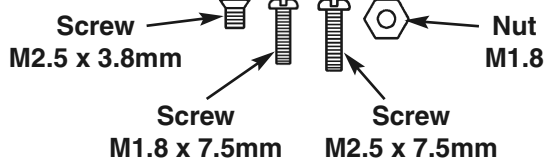

IDENTIFYING RESISTOR VALUES

Use the following information as a guide in properly identifying the value of resistors.

BAND 1 1st Digit	
Color	Digit
Black	0
Brown	1
Red	2
Orange	3
Yellow	4
Green	5
Blue	6
Violet	7
Gray	8
White	9

BAND 2 2nd Digit	
Color	Digit
Black	0
Brown	1
Red	2
Orange	3
Yellow	4
Green	5
Blue	6
Violet	7
Gray	8
White	9

Multiplier	
Color	Multiplier
Black	1
Brown	10
Red	100
Orange	1,000
Yellow	10,000
Green	100,000
Blue	1,000,000
Silver	0.01
Gold	0.1

Resistance Tolerance	
Color	Tolerance
Silver	±10%
Gold	±5%
Brown	±1%
Red	±2%
Orange	±3%
Green	±0.5%
Blue	±0.25%
Violet	±0.1%

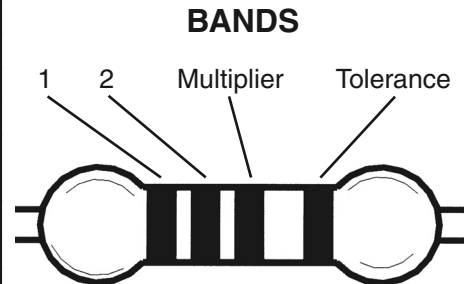

IDENTIFYING CAPACITOR VALUES

Capacitors will be identified by their capacitance value in pF (picofarads), nF (nanofarads), or μ F (microfarads). Most capacitors will have their actual value printed on them. Some capacitors may have their value printed in the following manner. The maximum operating voltage may also be printed on the capacitor.

Electrolytic capacitors have a positive and a negative electrode. The negative lead is indicated on the packaging by a stripe with minus signs and possibly arrowheads.

Multiplier	For the No.	0	1	2	3	4	5	8	9
		Multiply By	1	10	100	1k	10k	100k	.01

Second Digit → Multiplier

First Digit → Tolerance*



Maximum Working Voltage

The value is $10 \times 1,000 = 10,000\text{pF}$ or $.01\mu\text{F}$ 100V

* The letter M indicates a tolerance of $\pm 20\%$
 The letter K indicates a tolerance of $\pm 10\%$
 The letter J indicates a tolerance of $\pm 5\%$

Note: The letter "R" may be used at times to signify a decimal point; as in 3R3 = 3.3

Warning:

If the capacitor is connected with incorrect polarity, it may heat up and either leak, or cause the capacitor to explode.

Polarity Marking

METRIC UNITS AND CONVERSIONS

Abbreviation	Means	Multiply Unit By	Or
p	Pico	.000000000001	10^{-12}
n	nano	.000000001	10^{-9}
μ	micro	.000001	10^{-6}
m	milli	.001	10^{-3}
-	unit	1	10^0
k	kilo	1,000	10^3
M	mega	1,000,000	10^6

1. 1,000 pico units	= 1 nano unit
2. 1,000 nano units	= 1 micro unit
3. 1,000 micro units	= 1 milli unit
4. 1,000 milli units	= 1 unit
5. 1,000 units	= 1 kilo unit
6. 1,000 kilo units	= 1 mega unit

INTRODUCTION

The Elenco® Dual Audio Superhet 550C AM Radio is a “superheterodyne” receiver of the standard AM (amplitude modulated) broadcast frequencies. The unique design of the Superhet 550C allows you to place the parts over its corresponding symbol in the schematic drawing on the surface of the printed circuit board during assembly. This technique maximizes the learning process while keeping the chances of an assembly error at a minimum. It is very important, however, that good soldering practices are used to prevent bad connections. The Soldering Guide should be reviewed before any assembly is attempted.

The actual assembly is broken down into five sections. The theory of operation for each section, or stage, should be read before the assembly is started.

This will provide the student with an understanding of what that stage has been designed to accomplish, and how it actually works. After each assembly, you will be instructed to make certain tests and measurements to prove that each section is functioning properly. If a test fails to produce the proper results, a troubleshooting guide is provided to help you correct the problem. If test equipment is available, further measurements and calculations are demonstrated to allow each student to verify that each stage meets the engineering specifications. After all of the stages have been built and tested, a final alignment procedure is provided to peak the performance of the receiver and maximize the Dual Audio Superhet 550C’s reception capabilities.

GENERAL DISCUSSION

The Dual Audio Superhet 550C can best be understood by analysis of the block diagram shown in Figure 1.

The purpose of section 1, the Audio Amplifier Stage, is to increase the power of the audio signal received from the detector to a power level capable of driving the speaker. The audio amplifier is switchable between transistor or IC function.

Section 2 includes the detector circuit and the AGC (automatic gain control) circuit. The detector converts the amplitude modulated IF (intermediate frequency) signal to a low level audio signal. The AGC stage feeds back a DC voltage to the first IF amplifier in order to maintain a near constant level of audio at the detector. Section 3 is the second IF amplifier. The second IF amplifier is tuned to 455kHz (kilohertz) and has a fixed gain at this frequency of 100. The 3dB

bandwidth of this stage should be approximately 6kHz. Section 4 is the first IF amplifier which has a variable gain that depends on the AGC voltage received from the AGC stage. The first IF amplifier is also tuned to 455kHz and has a 3dB bandwidth of approximately 6kHz. Section 5 includes the mixer, oscillator and antenna stages. When the radio wave passes through the antenna, it induces a small voltage across the antenna coil. This voltage is coupled to the mixer, or converter, stage to be changed to a frequency of 455kHz. This change is accomplished by mixing (heterodyning) the radio frequency signal with the oscillator signal. Each of these blocks will be explained in detail in the Theory of Operation given before the assembly instructions for that stage.

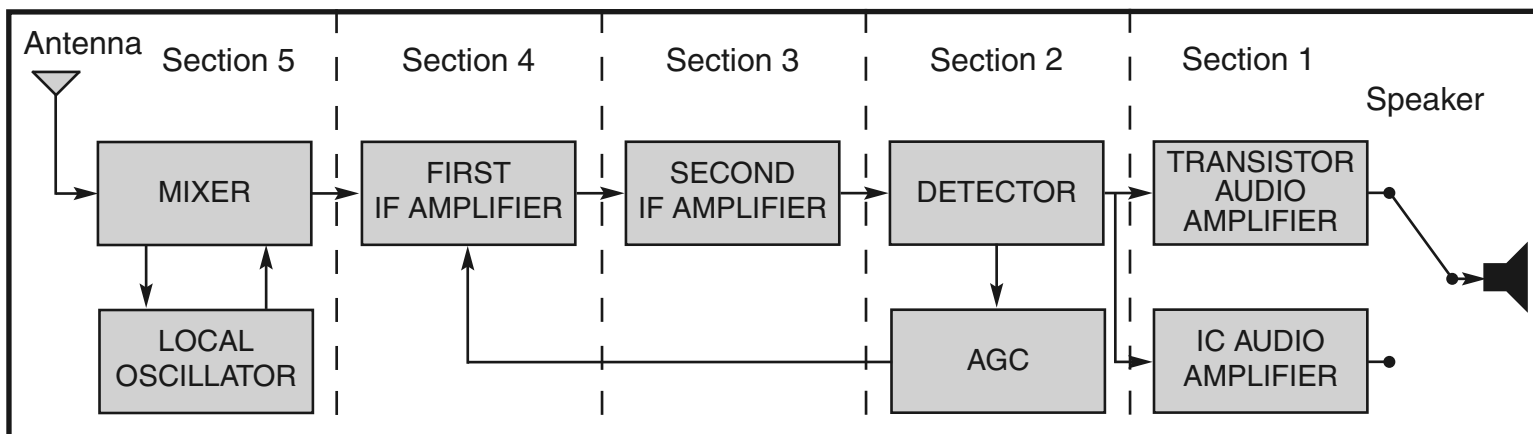

Figure 1

CONSTRUCTION

Introduction

The most important factor in assembling your Elenco® Dual Audio Superhet 550C AM Radio Kit is good soldering techniques. Using the proper soldering iron is of prime importance. A small pencil type soldering iron of 25 - 40 watts is recommended. **The tip of the iron must be kept clean at all times and well tinned.**

Solder

For many years leaded solder was the most common type of solder used by the electronics industry, but it is now being replaced by lead-free solder for health reasons. This kit contains **lead-free solder**, which contains 99.3% tin, 0.7% copper, and has a rosin-flux core.

Lead-free solder is different from lead solder: It has a higher melting point than lead solder, so you need higher temperature for the solder to flow properly. Recommended tip temperature is approximately 700°F; higher temperatures improve solder flow but accelerate tip decay. An increase in soldering time may be required to achieve good results. Soldering iron tips wear out faster since lead-free solders are more corrosive and the higher soldering temperatures accelerate corrosion, so proper tip care is important. The solder joint finish will look slightly duller with lead-free solders.

Use these procedures to increase the life of your soldering iron tip when using lead-free solder:

- Keep the iron tinned at all times.
- Use the correct tip size for best heat transfer. The conical tip is the most commonly used.

- Turn off iron when not in use or reduce temperature setting when using a soldering station.
- Tips should be cleaned frequently to remove oxidation before it becomes impossible to remove. Use Dry Tip Cleaner (Elenco® #SH-1025) or Tip Cleaner (Elenco® #TTC1). If you use a sponge to clean your tip, then use distilled water (tap water has impurities that accelerate corrosion).

Safety Procedures

- **Always wear safety glasses or safety goggles to protect your eyes when working with tools or soldering iron, and during all phases of testing.** 
- Be sure there is **adequate ventilation** when soldering.
- Locate soldering iron in an area where you do not have to go around it or reach over it. Keep it in a safe area away from the reach of children.
- **Do not hold solder in your mouth.** Solder is a toxic substance. Wash hands thoroughly after handling solder.

Assemble Components

In all of the following assembly steps, the components must be installed on the top side of the PC board unless otherwise indicated. The top legend shows where each component goes. The leads pass through the corresponding holes in the board and are soldered on the foil side.

Use only rosin core solder.

DO NOT USE ACID CORE SOLDER!

What Good Soldering Looks Like

A good solder connection should be bright, shiny, smooth, and uniformly flowed over all surfaces.

1. Solder all components from the copper foil side only. Push the soldering iron tip against both the lead and the circuit board foil.

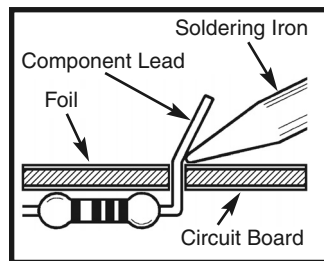

2. Apply a small amount of solder to the iron tip. This allows the heat to leave the iron and onto the foil. Immediately apply solder to the opposite side of the connection, away from the iron. Allow the heated component and the circuit foil to melt the solder.

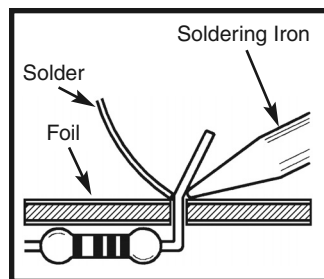

3. Allow the solder to flow around the connection. Then, remove the solder and the iron and let the connection cool. The solder should have flowed smoothly and not lump around the wire lead.

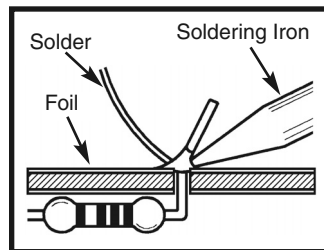

4. Here is what a good solder connection looks like.

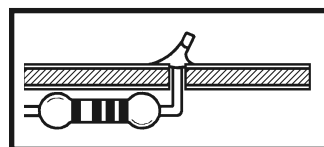

Types of Poor Soldering Connections

1. **Insufficient heat** - the solder will not flow onto the lead as shown.

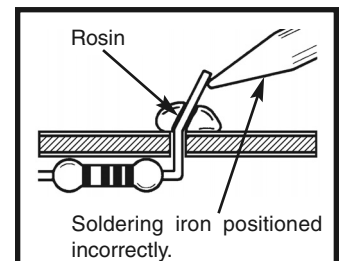

2. **Insufficient solder** - let the solder flow over the connection until it is covered. Use just enough solder to cover the connection.

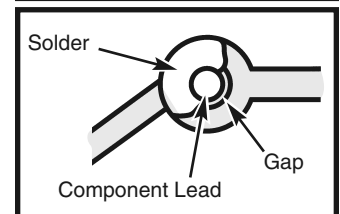

3. **Excessive solder** - could make connections that you did not intend to between adjacent foil areas or terminals.

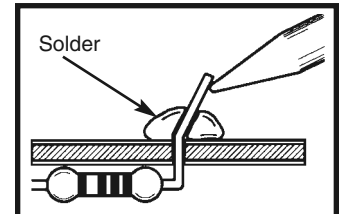

4. **Solder bridges** - occur when solder runs between circuit paths and creates a short circuit. This is usually caused by using too much solder. To correct this, simply drag your soldering iron across the solder bridge as shown.

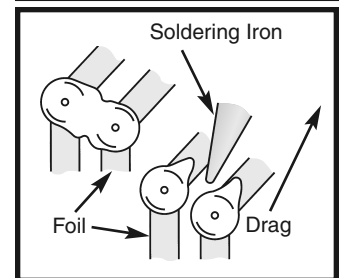

SEMICONDUCTOR PARTS FAMILIARIZATION

This section will familiarize you with the proper method used to test the transistors and the diode.

TRANSISTOR TEST

Refer to the parts list and find a NPN transistor. Refer the Figure C (page 8) for locating the Emitter, Base and Collector. Using an Ohmmeter, connect the transistor as shown in Test A. Your meter should be reading a low resistance. Switch the lead from the Emitter to the Collector. Your meter should again be reading a low resistance.

Using an Ohmmeter, connect the transistor as shown in Test B. Your meter should be reading a high resistance. Switch the lead from the Emitter to the Collector. Your meter should again be reading a high resistance. Typical results read approximately $1M\Omega$ to infinity.

Refer to parts list and find a PNP transistor, refer to Figure D (page 8) for locating the Emitter, Base and Collector. Using an Ohmmeter, connect the transistor as shown in Test C. Your meter should be reading a low resistance. Switch the lead from the Emitter to the Collector. Your meter should again be reading a low resistance.

Using an Ohmmeter, connect the transistor as shown in Test D. Your meter should be reading a high resistance. Switch the lead from the Emitter to the Collector. Your meter should again be reading a high resistance.

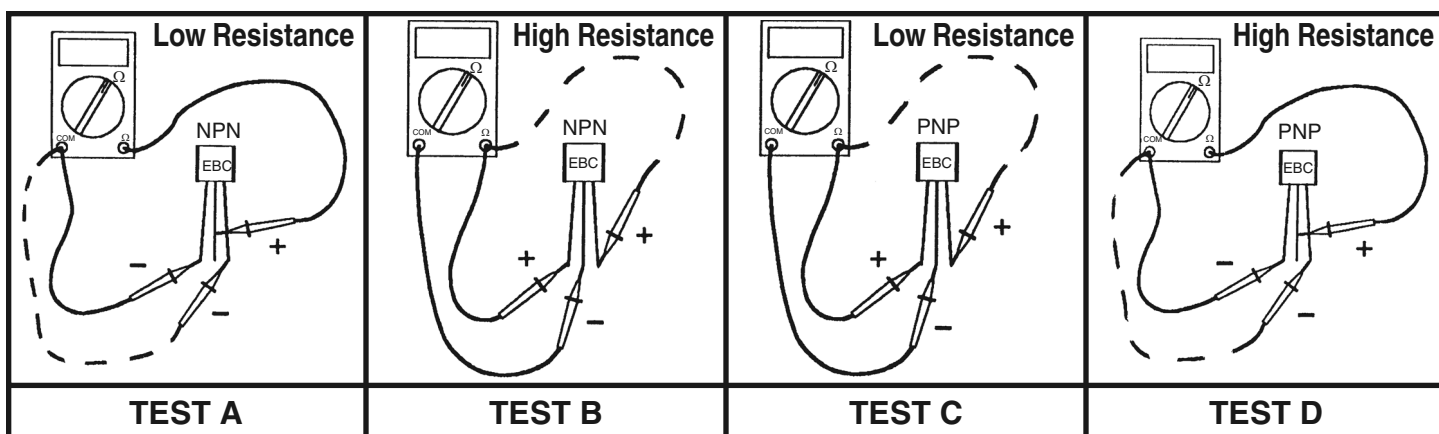

DIODE TEST

Refer to the parts list and find a diode. Refer to Figure E (page 8) for locating the Cathode and Anode. The end with the band is the cathode. Using an Ohmmeter, connect the diode as shown in Test E. Your meter should be reading a low resistance. Using an Ohmmeter,

connect the diode as shown in Test F. Your meter should be reading a high resistance. Typical results read approximately $1M\Omega$ to infinity for silicon diodes (1N4148).

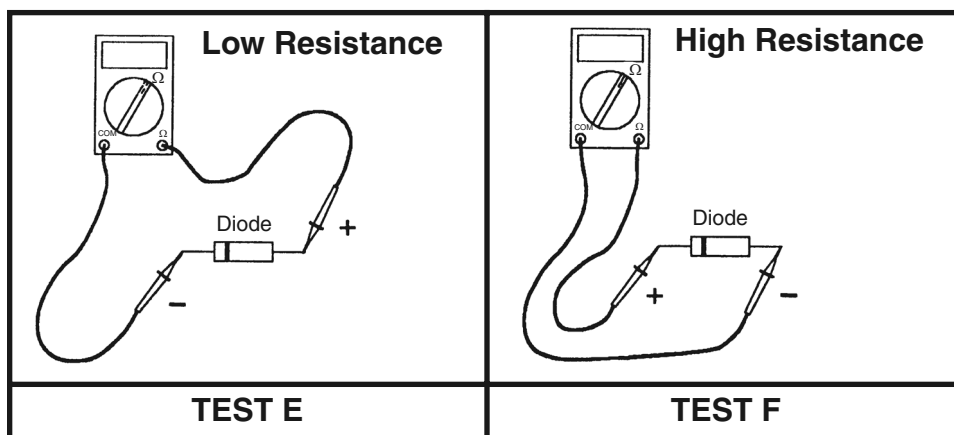

SECTION 1A

TRANSISTOR AUDIO AMPLIFIER

Theory of Operation - The purpose of the Audio Amplifier is to increase the audio power to a level sufficient to drive an 8 ohm speaker. To do this, DC (direct current) from the battery is converted by the amplifier to an AC (alternating current) in the speaker. The ratio of the power delivered to the speaker and the power taken from the battery is the efficiency of the amplifier. In a Class A amplifier (transistor on over entire cycle) the maximum theoretical efficiency is 0.5 or 50%, but in a Class B amplifier (transistor on for 1/2 cycle) the maximum theoretical efficiency is 0.785 or 78.5%. Since transistor characteristics are not ideal, in a pure Class B amplifier, the transistors will introduce crossover distortion. This is due to the non-linear transfer curve near zero current or cutoff. This type of distortion is shown in Figure 2.

In order to eliminate crossover distortion and maximize efficiency, the transistors (Q6 and Q7) of the audio amplifier circuit are biased on for slightly more than 1/2 of the cycle, Class AB. In other words, the transistors are working as Class A amplifiers for very small levels of power to the speaker, but they slide toward Class B operation at larger power levels.

Transistor Q4 is a Class A amplifier that drives the base of transistor Q5 directly. Q5 is a current amplifier that multiplies the collector current of Q4 by the beta (current gain, B) of Q5. The current from Q5 drives the output transistors Q6 and Q7 through the bias string R17, D2 and R18. Bias stability is achieved by using 100% DC feedback from the output stage to the emitter of Q4 through resistor R16. This gives the Audio Amplifier a DC gain of one. The AC gain is set by resistors R16, R15 and capacitor C12. In this circuit, the value of R16 is 1000 ohms and R15 is 100 ohms. Their ratio is 10 to 1, therefore the AC gain of the amplifier is 10 times. Resistors R13 and R14 set the DC voltage at the base of Q4 to approximately 5.2V. The emitter of Q4 is set at 4.5V, which is the same voltage at this output to the speaker. Note that this voltage is 1/2 the battery voltage. Capacitor C11 AC couples the audio signal from the volume control to the input of the Audio Amplifier. Capacitor C13 blocks the DC to the speaker, while allowing the AC to pass.

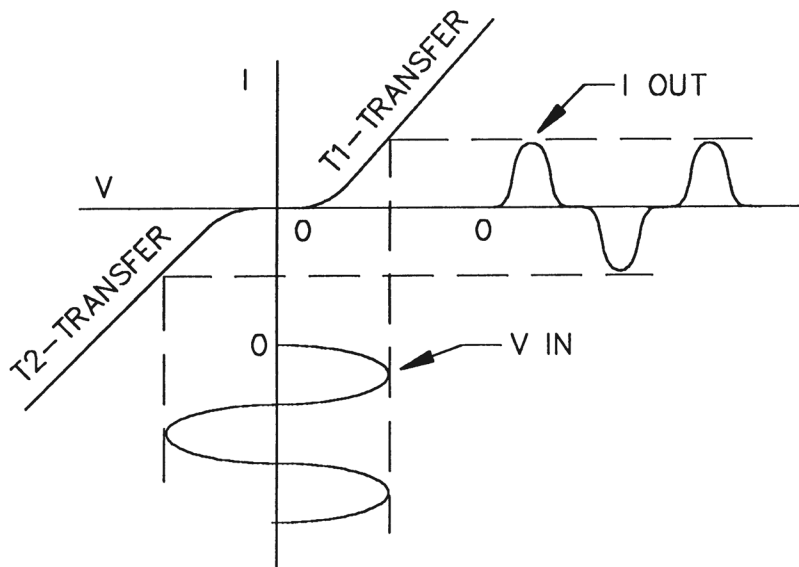
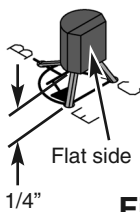

Figure 2

ASSEMBLY INSTRUCTIONS - AUDIO AMPLIFIER

We will begin by installing resistor R14. Identify the resistor by its color code and install as shown on page 3. Be careful to properly mount and solder all components. Diodes, transistors and electrolytic capacitors are polarized, be sure to follow the instructions carefully so that they are not mounted backwards. Check the box when you have completed each installation.

NPN Transistor



Mount so E lead is in the arrow hole and flat side is in the same direction as shown on the top legend. Leave 1/4" between the part and PC board.

Figure A

PNP Transistor

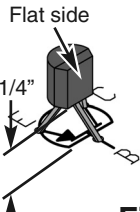

Mount so E lead is in the arrow hole and flat side is in the same direction as shown on the top legend. Leave 1/4" between the part and PC board.

Figure B

Jumper Wire

Use an excess lead to form a jumper wire. Bend the wire to the correct length and mount it to the PC board.



Figure C

- R14 - 47kΩ Resistor (yellow-violet-orange-gold)
- Q4 - 2N3904 Transistor NPN (see Figure A)
- TP6 - Test Point Pin (see Figure F)
- J1 - Jumper Wire (see Figure C)
- C11 - 10μF Lytic (see Figure Da)
- R13 - 82kΩ Resistor (gray-red-orange-gold)
- C14 - 470μF Lytic (see Figure Db)
- Pot / SW1 with Nut and Washer Knob (pot)
- Solder 5 lugs to PC board
- C12 - 47μF Lytic (see Figure Da)

Electrolytics have a polarity marking indicating the (-) lead. The PC board is marked to show the lead position.

Polarity mark

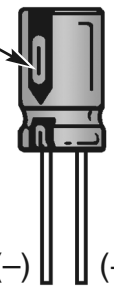

Figure Da

Warning: If the capacitor is connected with incorrect polarity, or if it is subjected to voltage exceeding its working voltage, it may heat up and either leak or cause the capacitor to explode.

Capacitor C14

For safety, solder capacitor C14 on the copper side as shown. Bend the leads 90° and insert into holes. Check that the polarity is correct, then solder in place. Trim the excess leads on legend side.

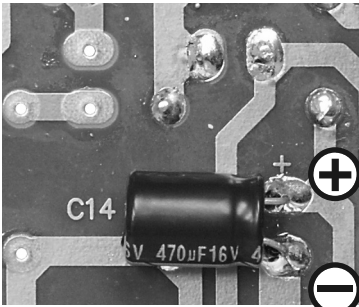

Figure Db

Diode

Be sure that the band is in the correct direction.

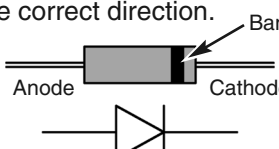

Figure E

Test Point Pin

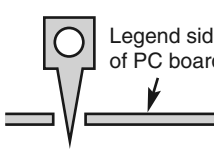
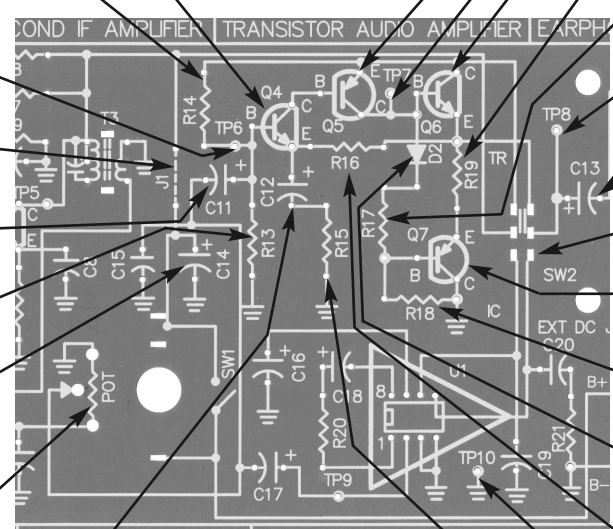
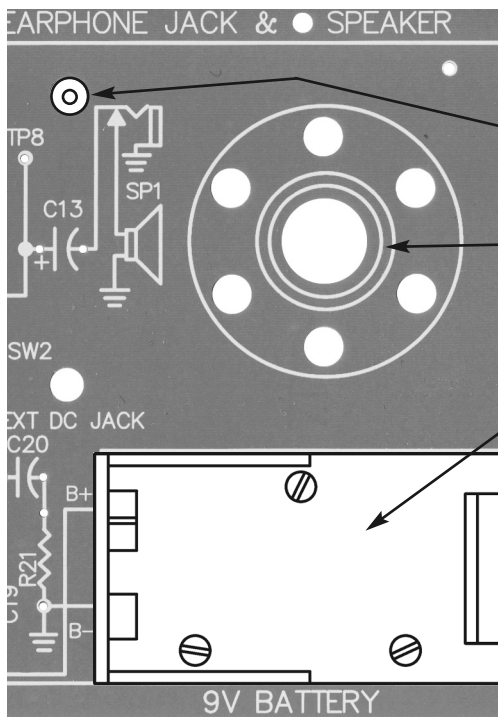

Figure F

- Q5 - 2N3906 Transistor PNP (see Figure B)
- TP7 - Test Point Pin (see Figure F)
- Q6 - MPS8050 (6560) Transistor NPN (see Figure A)
- R19 - 1Ω Resistor (brown-black-gold-gold)
- R17 - 100Ω Resistor (brown-black-brown-gold)
- TP8 - Test Point Pin (see Figure F)
- C13 - 470μF Lytic (see Figure Da)
- SW2 - Slide Switch
- Q7 - MPS8550 (6562) Transistor PNP (see Figure B)
- R18 - 820Ω Resistor (gray-red-brown-gold)
- D2 - 1N4148 Diode (see Figure E)
- R16 - 1kΩ Resistor (brown-black-red-gold)
- TP10 - Test Point Pin (see Figure F)
- R15 - 100Ω Resistor (brown-black-brown-gold)



ASSEMBLY INSTRUCTIONS



- J1 - Earphone Jack with Nut (see Figure G)
- Speaker
- Speaker Pad
- 4" Wire (see Figures H & I)
- Battery Holder
- 3 Screws M1.8 x 7.5mm
- 3 Nuts M1.8
- Solder and cut off excess leads.

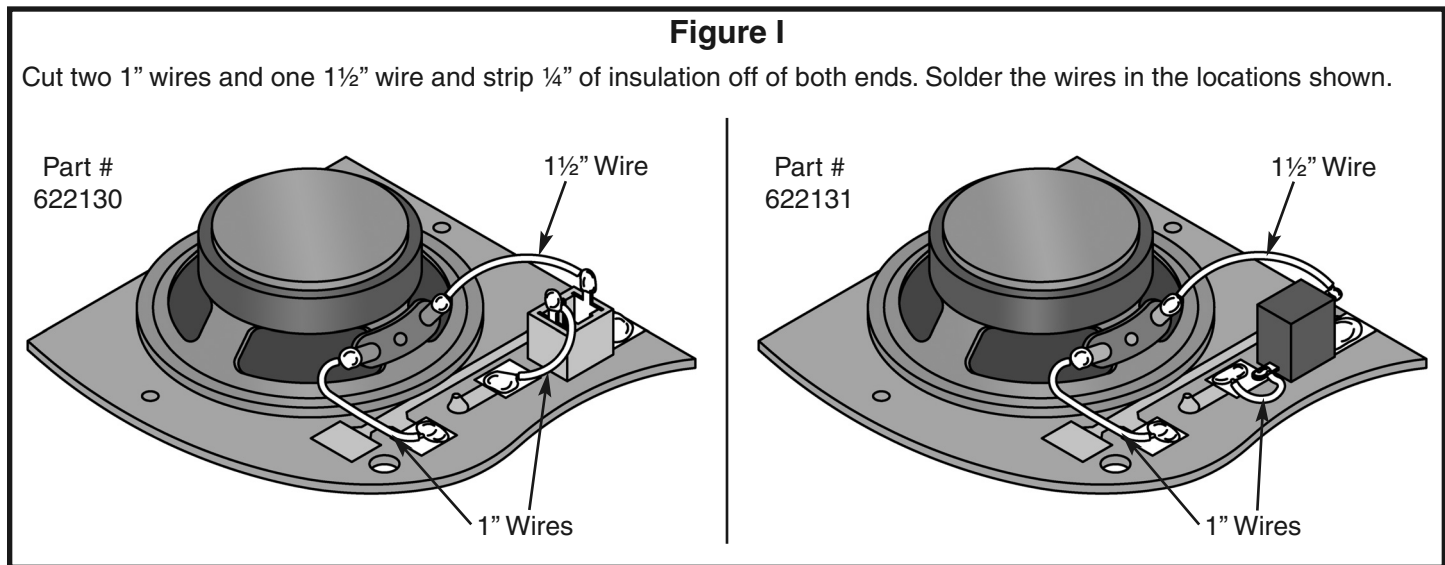
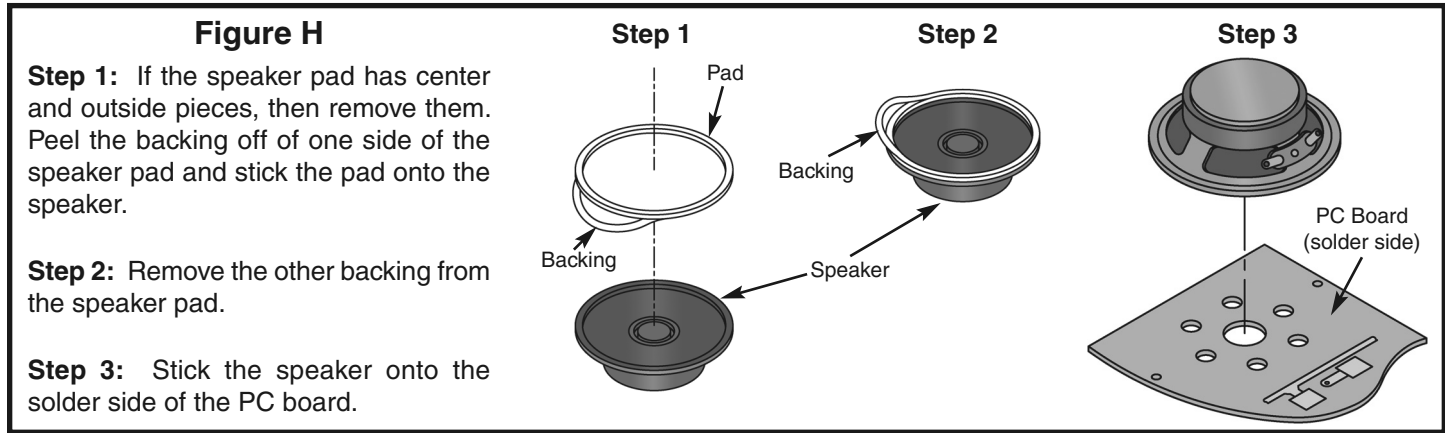
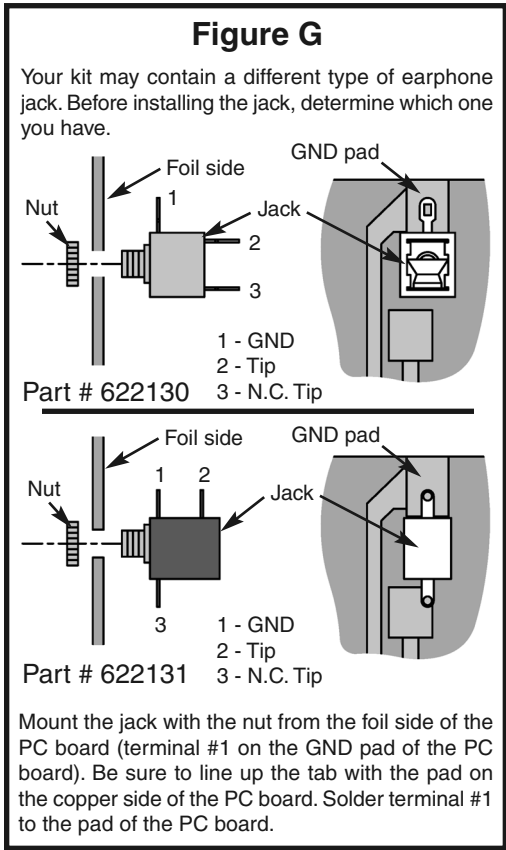

You have completed wiring the Transistor Audio Amplifier. We shall proceed in testing this circuit. You will need a Volt-Ohm-Milliammeter, preferably a digital type.

STATIC MEASUREMENTS - TRANSISTOR AUDIO AMPLIFIER (SW2 on the top [TR] position)

RESISTANCE TEST

Adjust the Volt-Ohm-Milliammeter (VOM) to the highest resistance scale available. Connect the VOM to the circuit as shown in Figure 3. Do not connect the battery.

The VOM should indicate a low resistance first and then as C14 charges, resistance should rise to approximately 100kΩ. If you get a lower reading, reverse multimeter

leads. If you get a reading lower than 20kΩ, check the circuit for shorts or parts inserted incorrectly. Check C14 to see if it's leaky or inserted backwards. If you get a reading higher than 150kΩ, check for open copper or bad solder connections on resistors R13 and R14.

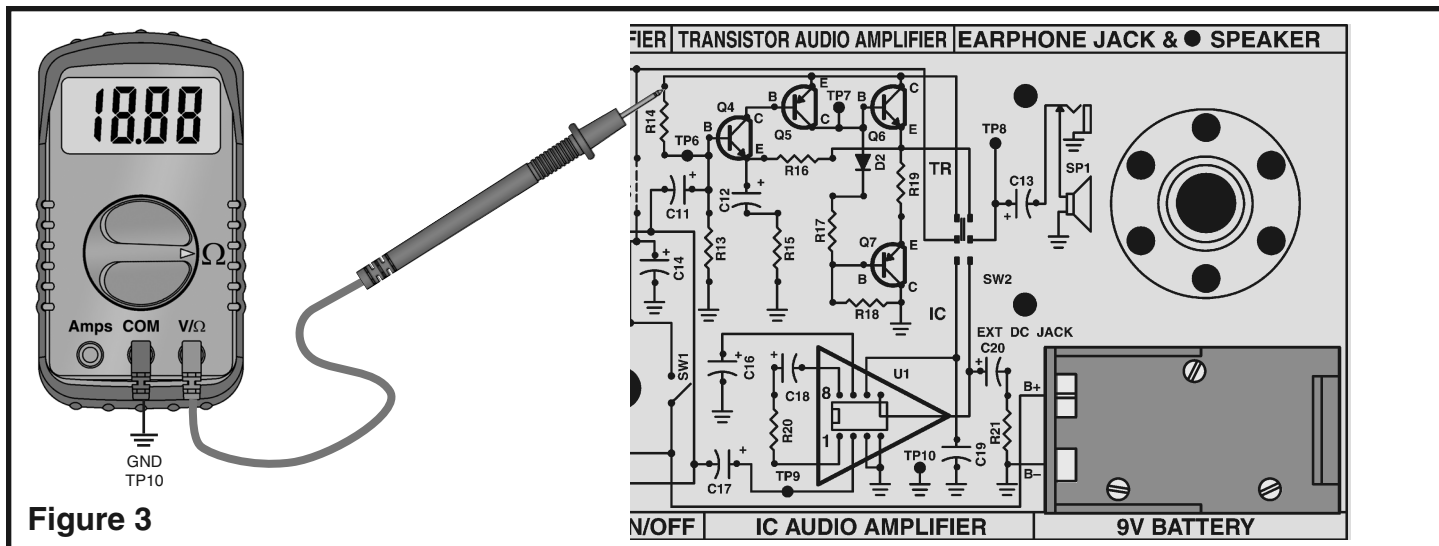

Figure 3

POWER UP TEST

Set your VOM to read the highest possible DC current. Connect the meter to the circuit as shown in Figure 4. Make sure that the On/Off switch (SW1) is in the OFF position.

While watching your VOM, flip switch SW1 to the ON position. The VOM should indicate a very low current.

Adjust your meter for a more accurate reading if necessary. If the current is greater than 25 milliamps, immediately turn the power off. The current should be between 5 and 15 milliamps. If you circuit fails this test, check that all parts have been installed correctly and check for shorts or poor solder connections. Turn OFF SW1.

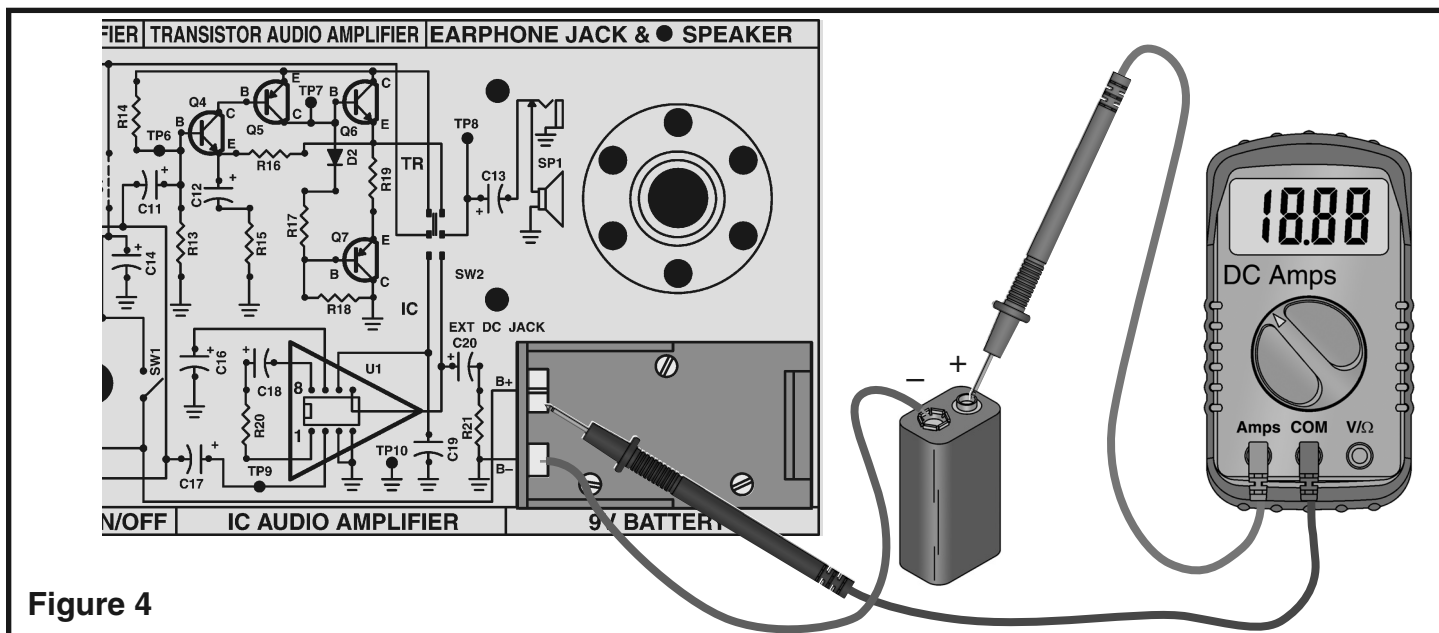

Figure 4

OUTPUT BIAS TEST

Adjust your VOM to read 9 volts DC and connect it to test point 8 (TP8) as shown in Figure 5.

Make sure that the battery, or a 9 volt power supply (if available), is properly connected and turn the power ON. The voltage at TP8 should be between 4.5 to 5.5 volts. If you get this reading, go on to the next test. If your

circuit fails this test, turn the power OFF and check that all of the transistors are correctly inserted in the correct locations. The E on the transistor indicates the emitter lead and should always be in the hole with the arrow. Check that resistors R13 and R14 are the correct values and not interchanged.

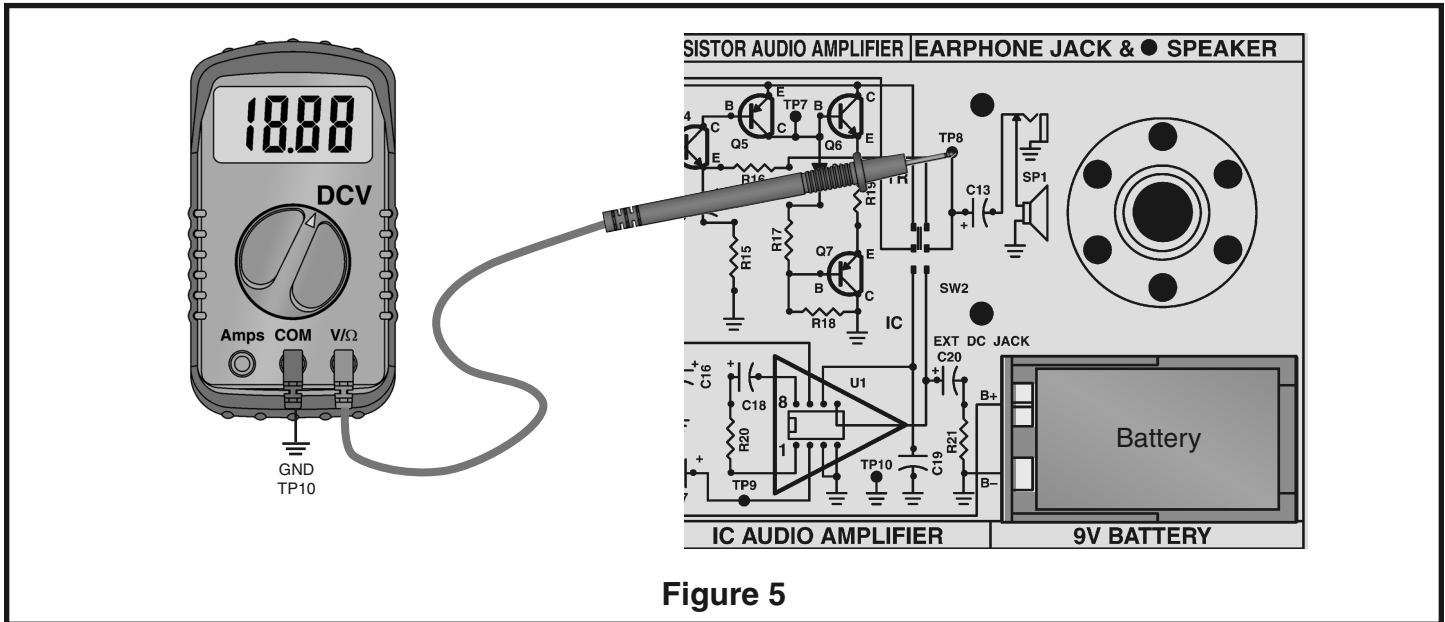

TRANSISTOR BIAS TEST

Move the positive lead of your VOM to test point 7 (TP7). Make sure that the power is ON. The voltage should be between 0.5 and 0.8V higher than the voltage at TP8. All silicon transistors biased for conduction will

have approximately 0.7V from the base to the emitter. If your circuit fails this test, turn off the power and check that Q6 is properly inserted into the circuit board.

INPUT BIAS

Move the positive lead of the VOM to test point 6 (TP6). Make sure that the power is ON. The voltage at TP6 should be very close to the voltage at TP7. This is true because very little DC current flows through resistor R16 making the voltage at the emitter of Q4 very close to the voltage at the emitter of Q6. If your circuit passes this

test, leave the VOM connected and go to test 1 in the Dynamic Measurements Section. If your circuit fails this test, turn the power OFF and check transistors Q4, Q7 and resistor R16. All static tests must pass before proceeding to the Dynamic Tests or the next section.

DYNAMIC MEASUREMENTS

DC GAIN

Adjust your VOM to read 9 volts DC. Connect the positive lead of the VOM to TP6 and the negative lead to TP10. Turn the power ON and record the voltage at TP6 here:

V1=_____ volts.

Place resistor R4 across resistor R13 as shown in Figure 6.

The voltage at TP6 should drop to a lower value. Record that lower voltage here:

V2=_____ volts.

Remove R4 from the circuit and move the positive lead of the VOM to TP8. Record the voltage at TP8 here:

V3=_____ volts.

Once again, parallel resistor R13 with resistor R4 as shown in Figure 6. The voltage at TP8 should also drop to a lower voltage. Record the new reading at TP8 here:

V4=_____ volts.

Remove R4 from the circuit but leave your VOM connected to TP8 for the next test. Turn the power OFF. Since the DC GAIN equals the DC change at the output divided by the DC change at the input, the DC gain of this amplifier is $(V1-V2)/(V3-V4)$. Your calculated answer should be very close to 1.

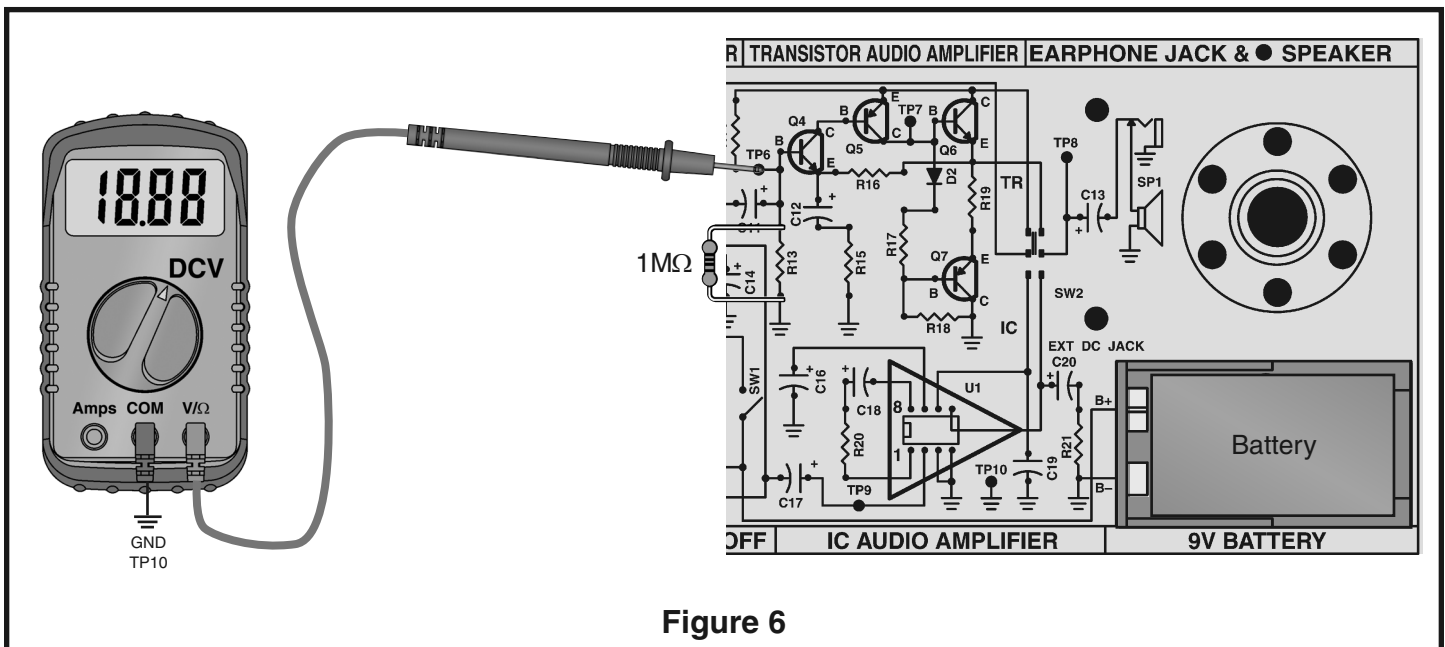

Figure 6

If you do not have a generator, skip the following test and go directly to Section 1B.

AC GAIN

Connect the VOM and generator to TP6 as shown in Figure 7.

Turn the power ON. Normally the AC gain is measured at a frequency of 1 kilohertz (kHz). Your VOM, however, may not be able to accurately read AC voltages at this frequency. It is recommended, therefore, that this test be performed at 400Hz. Set the generator at 400Hz and minimum voltage output. Set your VOM to read an AC voltage of 1 volt at the output of your Audio Amplifier. Slowly increase the output of the generator until the VOM reads 1 volt AC. Leave the audio at this setting and move

the positive lead of your VOM to TP6. Record the AC voltage input to the amplifier here:

V_{in} = _____ volts.

You may have to change scales on your VOM for the most accurate reading. Turn the power OFF. The AC voltage gain of your Audio Amplifier is equal to the AC output voltage divided by the AC input voltage, or $1/V_{in}$. Your calculated AC Gain should be approximately 10.

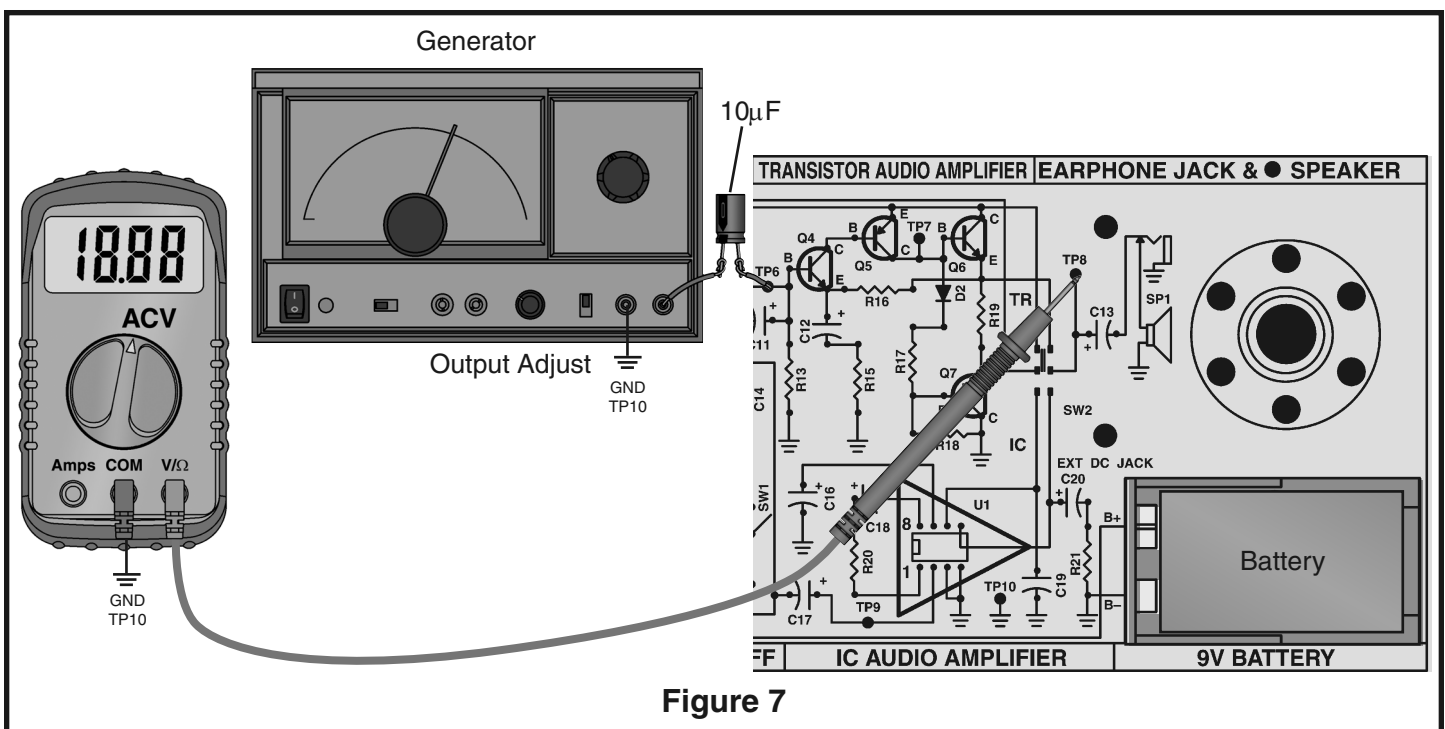

Figure 7

If an oscilloscope is not available, skip the following test and go directly to Section 2.

AC BANDWIDTH

Connect the oscilloscope (set to AC input measurement) and generator to your circuit as shown in Figure 8.

Set the generator for a frequency of 1kHz and minimum voltage output. Set the oscilloscope to read 0.5 volts per division. Turn the power ON and slowly increase the generator output until the oscilloscope displays 2 volts peak to peak (V_{pp}) at TP8. Move the oscilloscope probe to TP6 and record the input voltage here:

$$V_{in} = \text{_____ } V_{pp}$$

(at this point you may want to verify the AC Gain).

Move the oscilloscope probe back to TP8 and slowly increase the frequency from the generator until the

waveform on the oscilloscope drops to 0.7 of its original reading, 1.4 V_{pp} or 2.8 divisions. Use the oscilloscope probe to check TP6 to make sure the input voltage did not change. The frequency of the generator when the output drops to 0.7 of its original value is called the high frequency 3 decibel (dB) corner.

Repeat this procedure by lowering the frequency from the generator to obtain the low frequency 3dB corner. Leave the oscilloscope connected to TP8 and turn the power OFF. By subtracting the frequency of the low corner from the frequency of the high corner, you calculate the bandwidth of the Audio Amplifier. Your bandwidth should be greater than 100kHz.

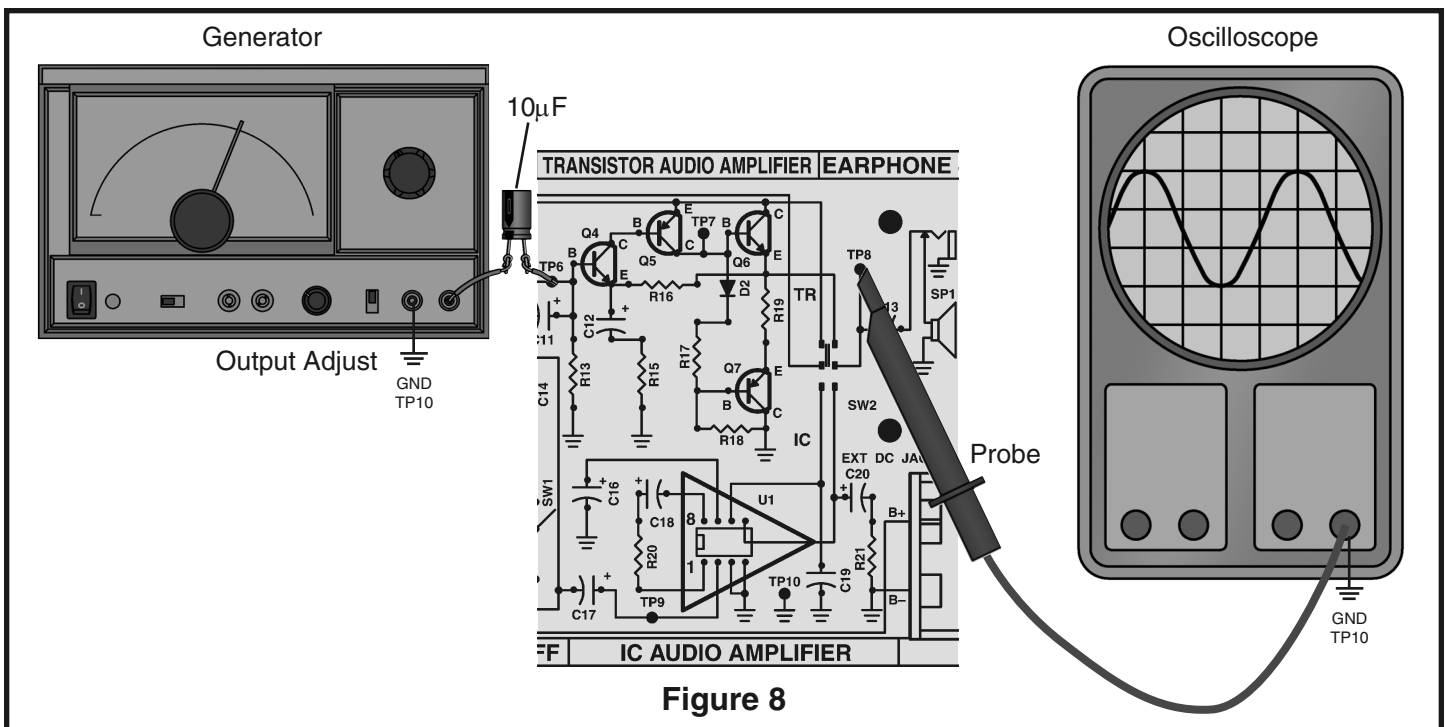
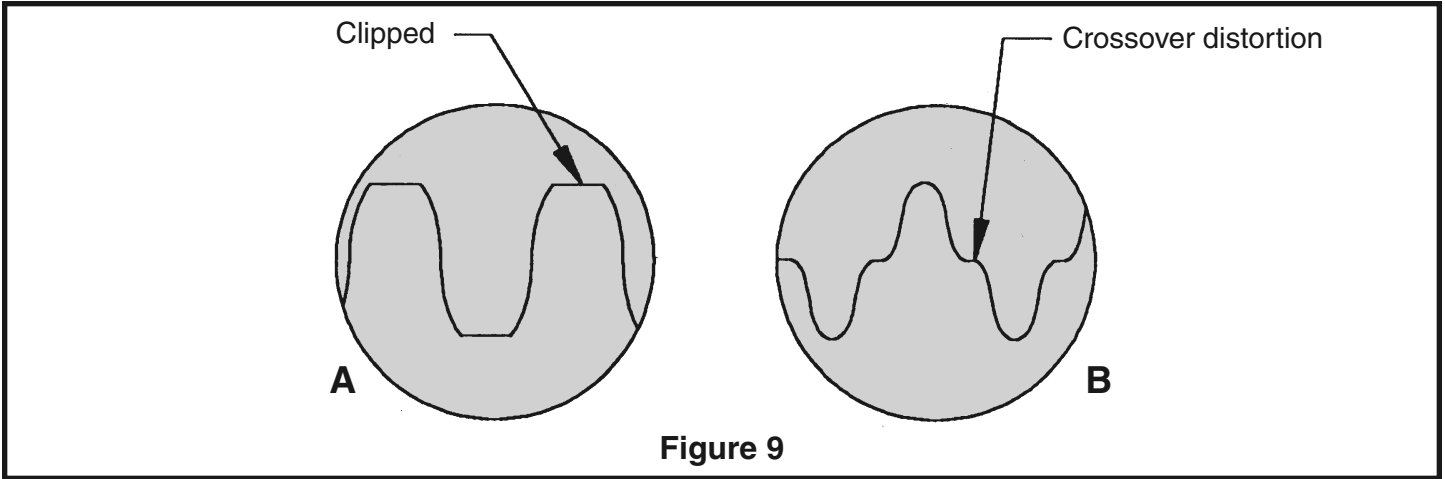

Figure 8

DISTORTION

Connect the generator and oscilloscope as shown in Figure 8. Set the generator at a frequency of 1kHz, turn the power ON and adjust the generator output until the

peaks of the sinewave at TP8 are clipped as shown in Figure 9A.



Measure the maximum voltage peak to peak when clipping first occurs and record that value here:

$$V_{clp} = \text{_____ } V_{pp}$$

Using a wire short out resistor R17 and diode D2 as shown in Figure 10.

The waveform on your oscilloscope should resemble Figure 9B. The “flat spots” near the center of each sinewave demonstrate what is called crossover distortion. This distortion should disappear when you remove the shorting lead. Turn the power OFF

MAXIMUM POWER OUTPUT

The maximum power output before distortion due to “clipping” can be calculated using the voltage V_{clp} obtained in step 4 as follows:

$$V_{peak} (V_p) = V_{clp}/2$$

$$V_{root\ mean\ squared} (V_{rms}) = V_p \times .7$$

$$\text{Max power out} = (V_{rms})^2/8\ \text{ohms} = (V_{clp} \times .35)^2/8$$

Maximum power output should be greater than 200 milliwatts.

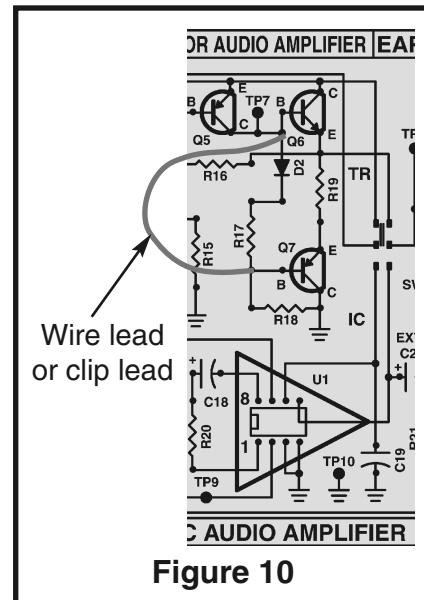

EFFICIENCY

By measuring the DC power taken from the battery at the maximum power output level, the efficiency to the Audio Amplifier can be calculated. Power from the battery is equal to the current taken from the battery times the voltage of the battery during maximum power output. It is best to use a power supply to prevent battery

voltage from changing during this measurement. Efficiency can then be calculated as follows:

$$\text{Eff} = \frac{\text{Max audio power}}{\text{Battery power}}$$

SECTION 1B

INTEGRATED CIRCUIT (IC) AUDIO AMPLIFIER

For the IC Audio Amplifier, we use the integrated circuit (IC) LM-386. In Figure 11, you can see equivalent schematic and connection diagrams.

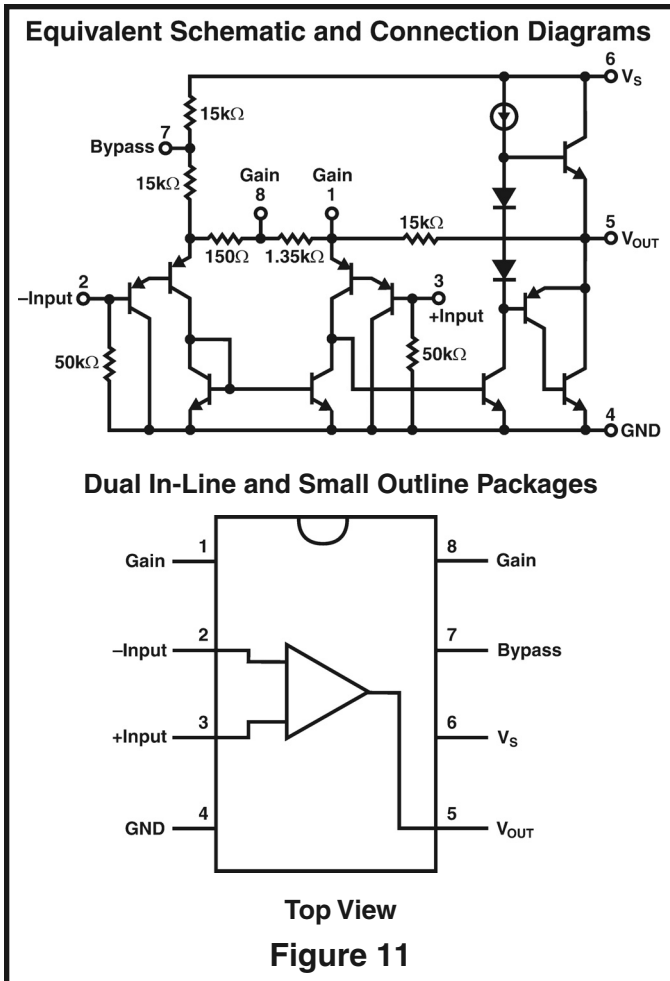

To make the LM-386 a more versatile amplifier, two pins (1 and 8) are provided for gain control. With pins 1 and 8 open, the 1.35kΩ resistor sets the gain at 20 (see Figure 12a). The gain will go up to 200 (see Figure 12b) if a capacitor is placed between pins 1 and 8. The gain can be set to any value from 20 to 200 if a resistor is placed in series with the capacitor.

The amplifier in our kit with a gain of 50 is shown in Figure 13. Capacitor C11 couples the audio signal from the volume control to the input of the audio amplifier. Capacitor C13 blocks the DC to the speaker, while allowing the AC to pass.

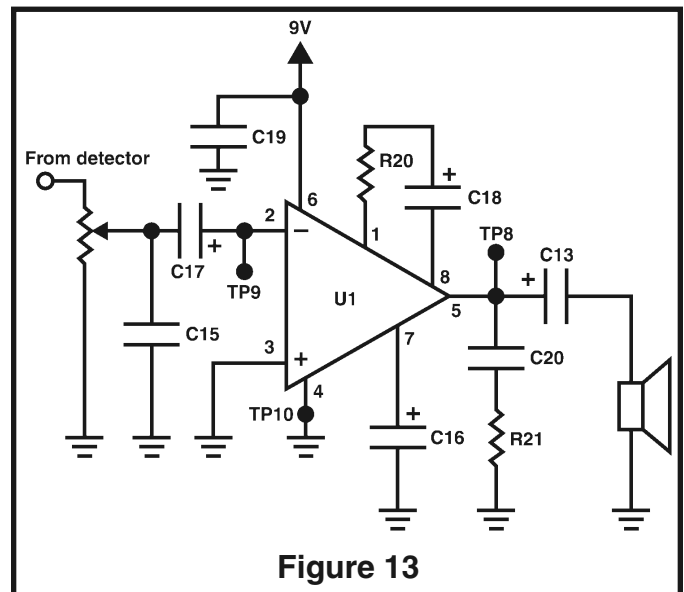
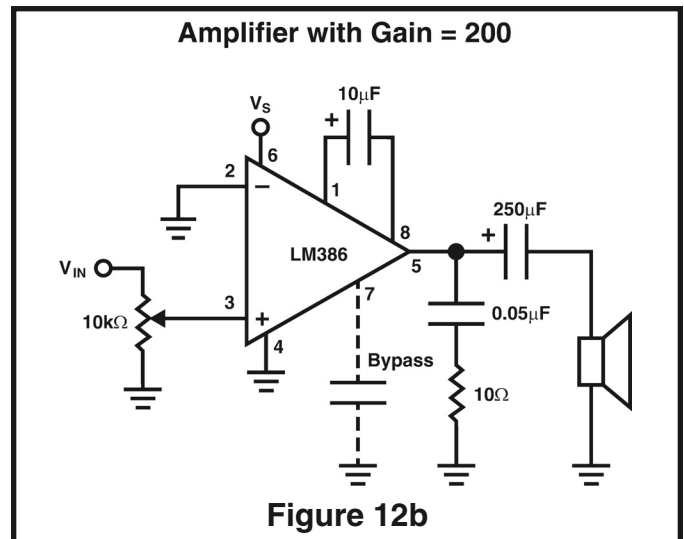
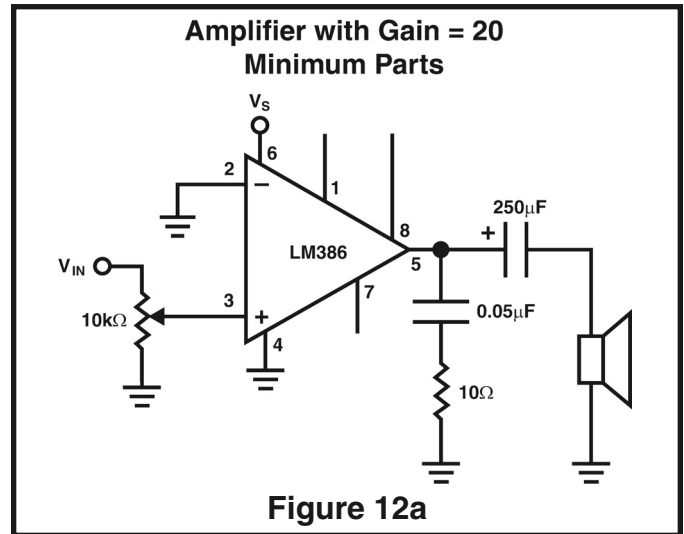

ASSEMBLY INSTRUCTIONS

- C20 - .047 μ F (473) Discap
- C18 - 10 μ F Lytic Capacitor
- C16 - 10 μ F Lytic Capacitor (see Figure Da)
- R20 - 1.2k Ω 5% 1/4W Resistor (brown-red-red-gold)
- TP9 - Test Point Pin (see Figure F)
- C17 - 10 μ F Lytic Capacitor (see Figure Da)
- U1 - IC Socket 8-Pin
- U1 - Integrated Circuit LM-386 (see Figure J)
- C19 - 0.1 μ F Discap (104)
- R21 - 10 Ω 5% 1/4W Resistor (brown-black-black-gold)

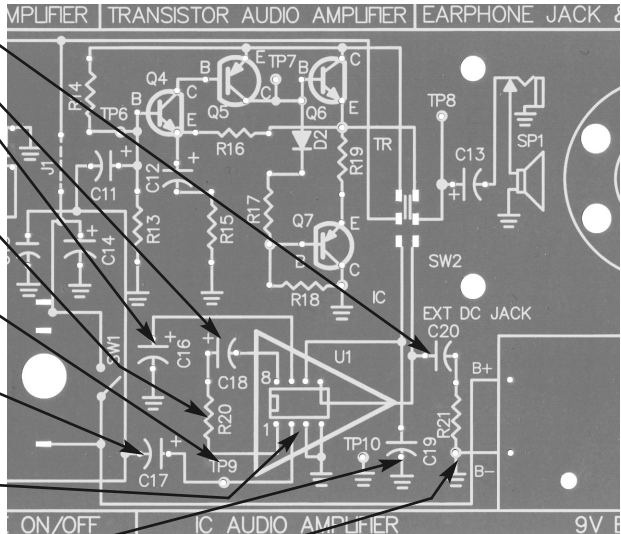

Integrated Circuit

Insert the IC socket into the PC board with the notch in the direction shown on the top legend. Solder the IC socket into place. Insert the IC into the socket with the notch in the same direction as the notch on the socket.

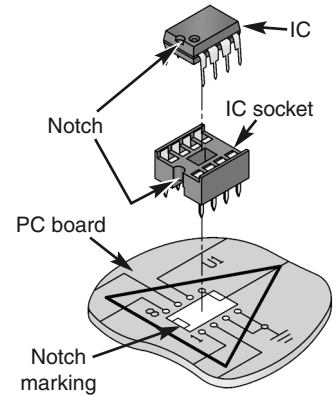

Figure J

You have completed wiring the IC Audio Amplifier. We shall proceed in testing this circuit. You will need for static measurements, a Volt-Ohm-Milliammeter, preferably a digital type.

STATIC MEASUREMENTS - IC AUDIO AMPLIFIER (SW2 on the down [IC] position)

RESISTANCE TEST

Adjust the Volt-Ohm-Milliammeter (VOM) to the highest resistance scale available. Connect the VOM to pin 6 of the IC as shown in Figure 14. Do not connect the battery. The VOM should indicate a low resistance first and then as C14 charges, resistance should rise to approximately

4M Ω . If you get a lower reading, reverse multimeter leads. If you get a reading lower than 100k Ω , check the circuit for shorts or parts inserted incorrectly. If you get a reading higher than 10M Ω , check for open copper or bad solder connections on all components.

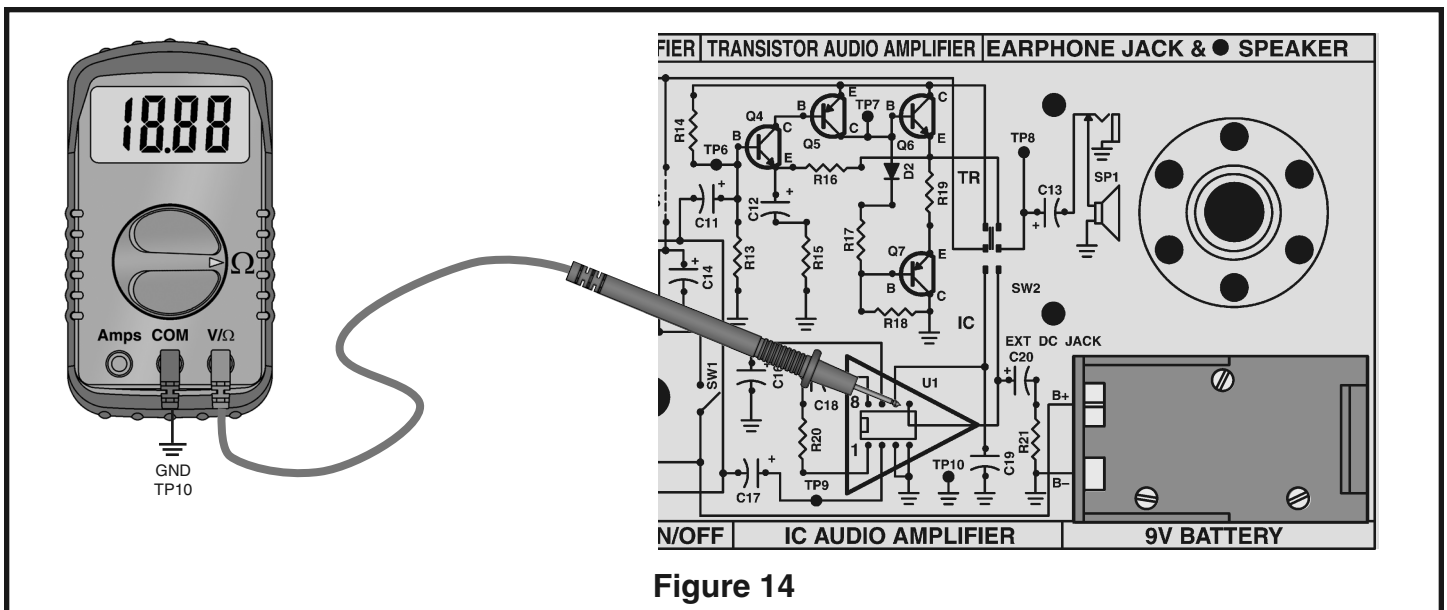

Figure 14

POWER UP TEST

Set your VOM to read the highest possible DC current. Connect the meter to the circuit as shown in Figure 15. Make sure that the On/Off switch (SW1) is in the OFF position.

While watching your VOM, flip switch SW1 to the ON position. The VOM should indicate a very low current. Adjust your meter for a more accurate reading if

necessary. If the current is greater than 25 milliamps, immediately turn the power off. The current should be between 3 and 15 milliamps. If your circuit fails this test, check that all parts have been installed correctly and check for shorts or poor solder connections. Turn OFF SW1.

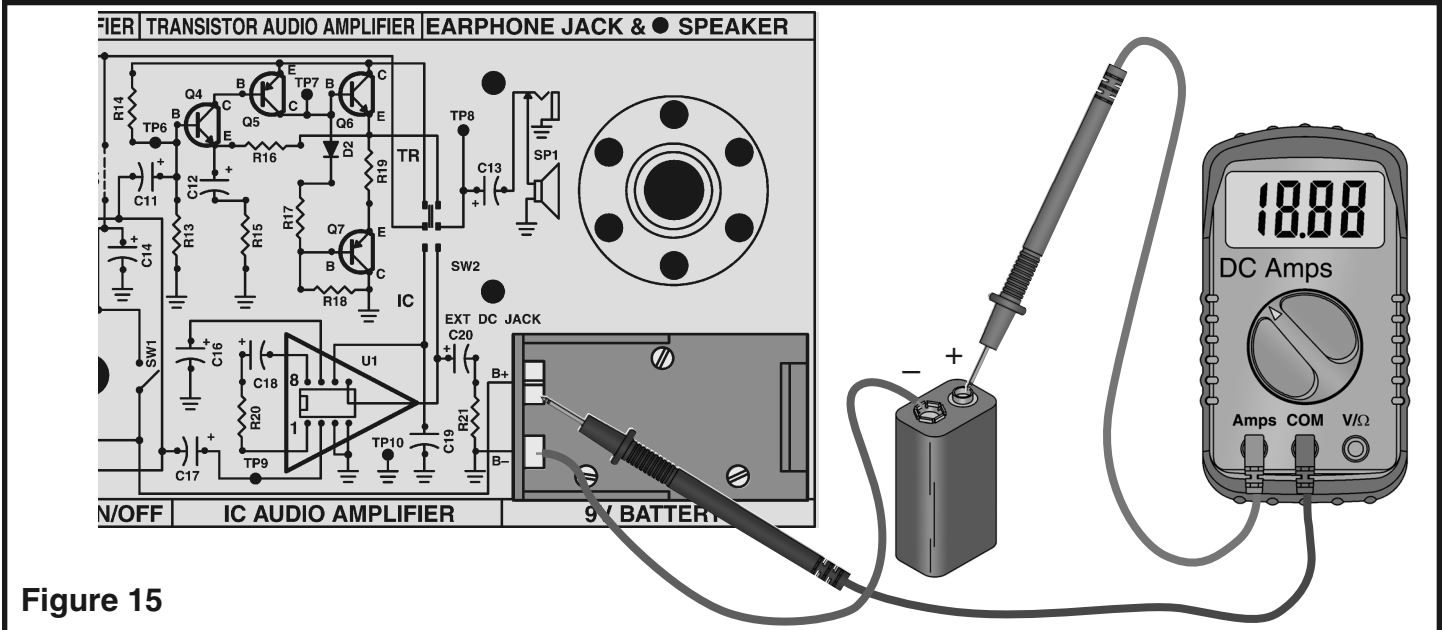

Figure 15

OUTPUT BIAS TEST

Adjust your VOM to read 9 volts DC and connect it to test point 8 (TP8) as shown in Figure 16.

Make sure that the battery, or a 9 volt power supply (if available), is properly connected and turn the power ON. The voltage at TP8 should be between 4 to 5 volts. If you get this reading, go on to the next test. If your circuit fails this test, turn the power OFF and check that the integrated circuit is correctly inserted in the correct locations.

INPUT BIAS

Move the positive lead of the VOM to test point 9 (TP9). Make sure that the power is ON. The voltage at TP9 should be close to the voltage at test point 10 (TP10). If your circuit passes this test, leave the VOM connected and go to test 1 in the Dynamic Measurements Section. If your circuit fails this test, turn the power OFF and check the IC. All static tests must pass before proceeding to the Dynamic Tests or the next section.

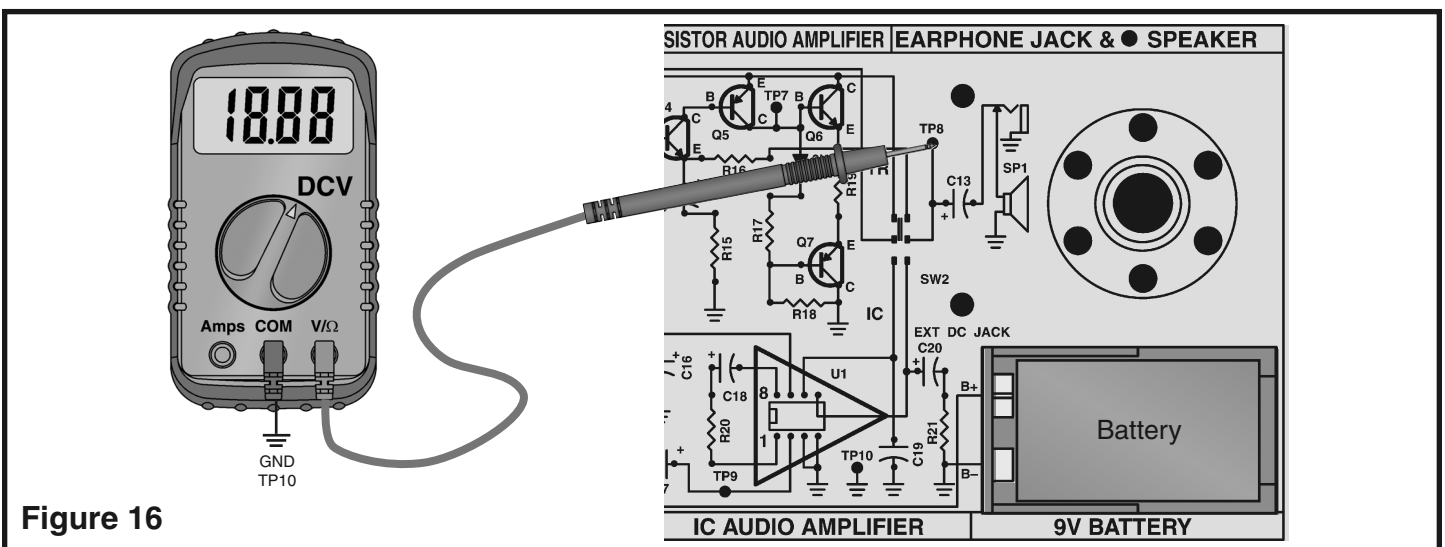

Figure 16

If you do not have an audio generator, skip the following test and go directly to Section 2.

DYNAMIC MEASUREMENTS

AC GAIN

Connect the VOM and audio generator as shown in Figure 17. Turn the power ON. Normally the AC gain is measured at a frequency of 1 kilohertz (kHz). Your VOM, however, may not be able to accurately read AC voltages at this frequency. It is recommended, therefore, that this test be performed at 400Hz. Set the audio generator at 400Hz and minimum voltage output. Set your VOM to read an AC voltage of 1 volt at the output of your Audio Amplifier (TP8). Slowly increase the output of the audio

generator until the VOM reads 1 volt AC. Leave the audio at this setting and move the positive lead of your VOM to TP9. Record the AC voltage input to the amplifier here: $V_{in} = \underline{\hspace{2cm}}$ volts. You may have to change scales on your VOM for the most accurate reading. Turn the power OFF. The AC voltage gain of your Audio Amplifier is equal to the AC output voltage divided by the AC input voltage, or $1/V_{in}$. Your calculated AC Gain should be approximately 30 - 50.

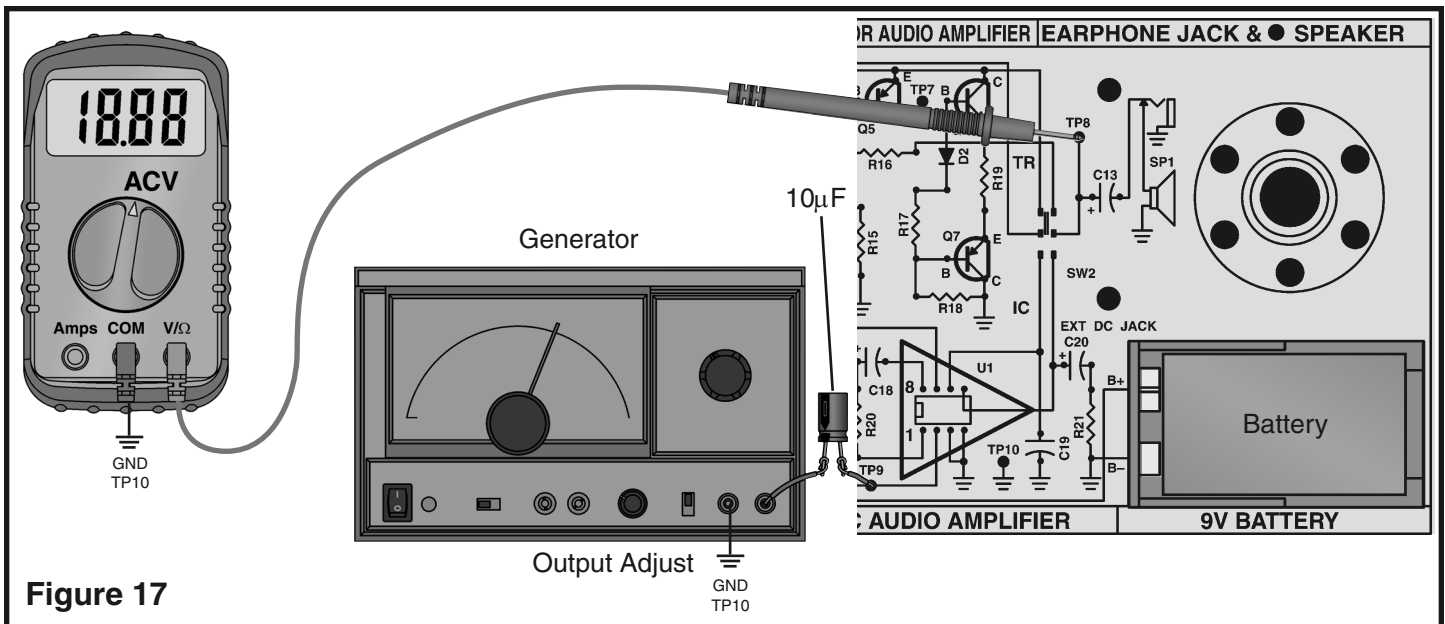

Figure 17

If an oscilloscope is not available, skip the following test and go directly to Section 2.

AC BANDWIDTH

Connect the oscilloscope and audio generator to your circuit as shown in Figure 18.

Set the audio generator for a frequency of 1kHz and minimum voltage output. Set the oscilloscope to read 0.5 volts per division. Turn the power ON and slowly increase the generator output until the oscilloscope displays 2 volts peak to peak (Vpp) at TP8. Move the oscilloscope probe to TP9 and record the input voltage here: $V_{in} = \underline{\hspace{2cm}}$ Vpp, (at this point you may want to verify the AC Gain). Move the oscilloscope probe back to TP8 and slowly increase the frequency from the audio generator until the waveform on the oscilloscope drops to 0.7 of its original reading, 1.4 Vpp or 2.8

divisions. Use the oscilloscope probe to check TP9 to make sure the input voltage did not change. The frequency of the generator when the output drops to 0.7 of its original value is called the high frequency 3 decibel (dB) corner.

Repeat this procedure by lowering the frequency from the generator to obtain the low frequency 3dB corner. Leave the oscilloscope connected to TP8 and turn the power OFF. By subtracting the frequency of the low corner from the frequency of the high corner, you calculate the bandwidth of the Audio Amplifier. Your bandwidth should be greater than 100kHz.

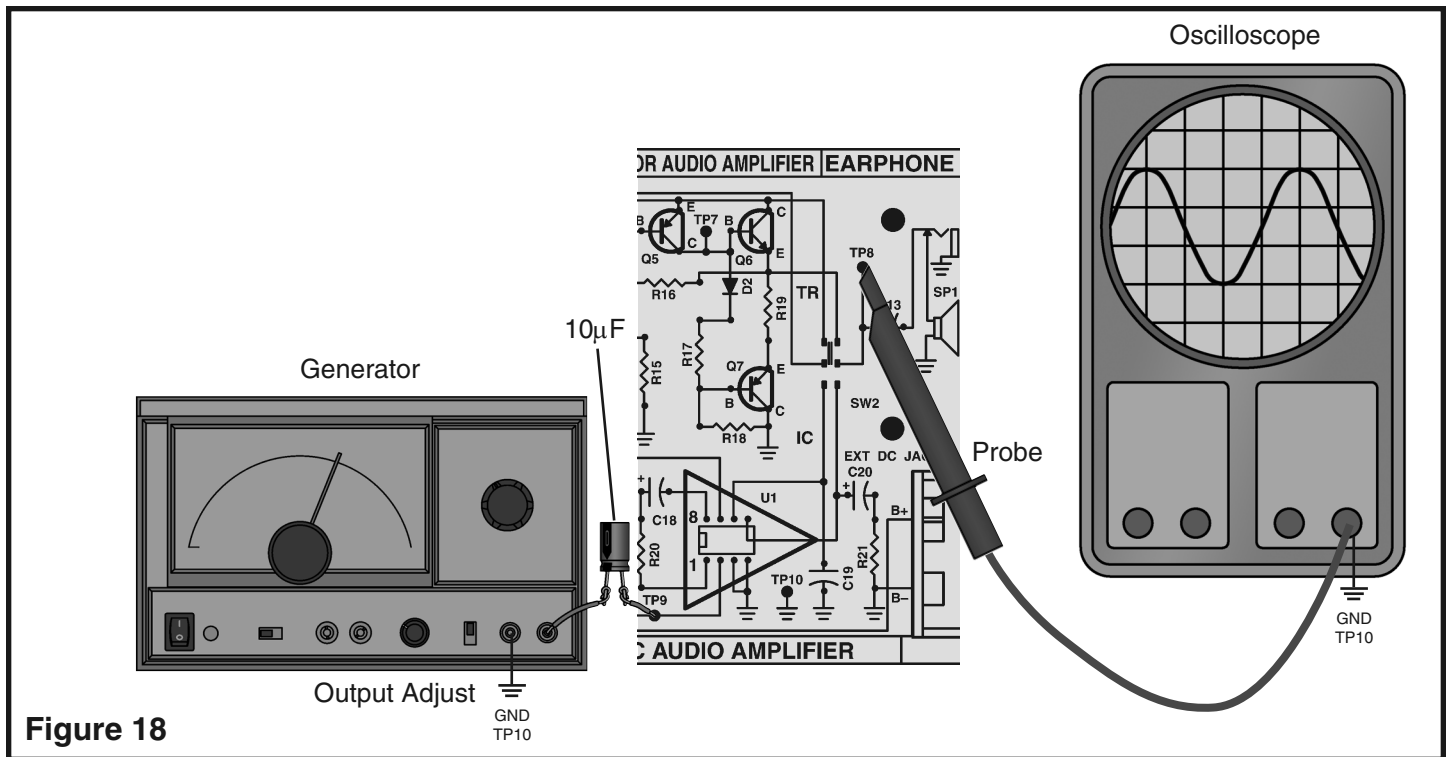

Figure 18

DISTORTION

Connect the generator and oscilloscope as shown in Figure 18. Set the generator at a frequency of 1kHz, turn the power ON and adjust the generator output until the

peaks of the sinewave at TP8 are clipped as shown in Figure 9A.

Measure the maximum voltage peak to peak when clipping first occurs and record that value here:

$$V_{clp} = \text{_____ } V_{pp}.$$

MAXIMUM POWER OUTPUT

The maximum power output before distortion due to “clipping” can be calculated using the voltage V_{clp} obtained in step 3 as follows:

$$V_{peak} (V_p) = V_{clp}/2$$

$$V_{root\ mean\ squared} (V_{rms}) = V_p \times .7$$

$$\text{Max power out} = (V_{rms})^2/8\ \text{ohms} = (V_{clp} \times .35)^2/8$$

Maximum power output should be greater than 200 milliwatts.

EFFICIENCY

By measuring the DC power taken from the battery at the maximum power output level, the efficiency to the Audio Amplifier can be calculated. Power from the battery is equal to the current taken from the battery times the voltage of the battery during maximum power

output. It is best to use a power supply to prevent battery voltage from changing during this measurement. Efficiency can then be calculated as follows:

$$\text{Eff} = \frac{\text{Max power output}}{\text{Battery power}}$$



SECTION 2

AM DETECTOR AND AGC STAGES

THEORY OF OPERATION

The purpose of the detector is to change the amplitude modulated IF signal back to an audio signal. This is accomplished by a process called detection or demodulation. First, the amplitude modulated IF signal is applied to a diode in such a way as to leave only the negative portion of that signal (see Figure 19). The diode acts like an electronic check valve that only lets current pass in the same direction as the arrow (in the diode symbol) points. When the diode is in conduction (On Condition), it will force capacitors C9 and C10 to charge to approximately the same voltage as the negative peak of the IF signal. After conduction stops in the diode (Off Condition), the capacitors will discharge through resistors R11, R12 and the volume control. The discharge time constant for this circuit must be small enough to follow the audio signal or high frequency audio distortion will occur. The discharge time constant must be large enough, however, to remove the intermediate frequency (455kHz) and leave only the audio at the volume control as shown in Figure 19.

The purpose of the automatic gain control (AGC) circuit is to maintain a constant audio level at the detector, regardless of the strength of the incoming signal. Without AGC, the volume control would have to be adjusted for each station and even moderately strong stations would clip in the final IF amplifier causing audio distortion. AGC is accomplished by adjusting the DC bias of the first IF amplifier to lower its gain as the signal strength increases. Figure 19 shows that the audio at the top of the volume control is actually "riding" on a negative DC voltage when strong signals are encountered. This negative DC component corresponds to the strength of the incoming signal. The larger the signal, the more negative the component. At test point three (TP3), the audio is removed by a low pass filter, R11 and C4, leaving only the DC component. Resistor R5 is used to shift the voltage at TP3 high enough to bias the base of transistor Q2 to the full gain position when no signal is present. Resistors R5 and R11 also forward bias diode D1 just enough to minimize "On Condition" threshold voltage.

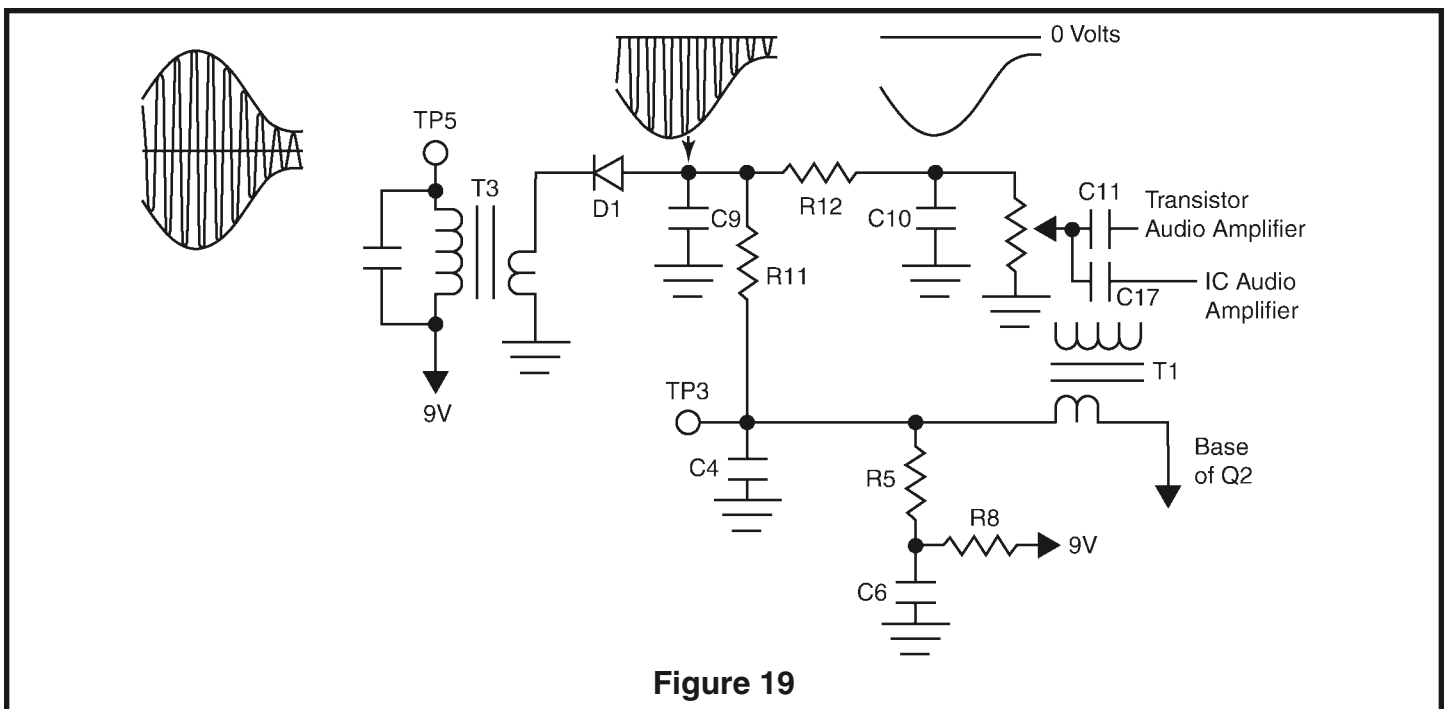
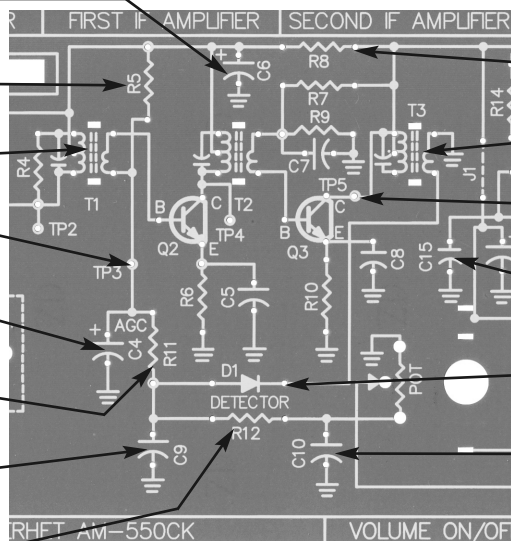

Figure 19

ASSEMBLY INSTRUCTIONS - DETECTOR

- C6 - 100 μ F Lytic
(see Figure Da)
- R5 - 27k Ω Resistor
(red-violet-orange-gold)
- T1 - IF Coil (yellow)
- TP3 - Test Point Pin
(see Figure F)
- C4 - 10 μ F Lytic
(see Figure Da)
- R11 - 3.3k Ω Resistor
(orange-orange-red-gold)
- C9 - .02 μ F or .022 μ F Discap
(marked 203 or 223)
- R12 - 2.2k Ω Resistor
(red-red-red-gold)



- R8 - 100 Ω Resistor
(brown-black-brown-gold)
- T3 - IF Coil (black)
- TP5 - Test Point Pin
(see Figure F)
- C15 - .001 μ F Discap
(marked 102)
- D1 - 1N4148 Diode
(see Figure E)
- C10 - .01 μ F Discap
(marked 103)

STATIC MEASUREMENTS

(SW2 on the top [TR] position)

AGC ZERO SIGNAL BIAS

With the power turned OFF, connect the VOM to test point three (TP3) as shown in Figure 20. Check that the VOM is adjusted to read 9 volts DC and turn the power ON. The voltmeter should read

approximately 1.5 volts DC. If your reading varies more than 0.5 volts from this value, turn the power OFF and check the polarity of D1, and resistors R11 and R5. Also check that transformer T1 is properly installed.

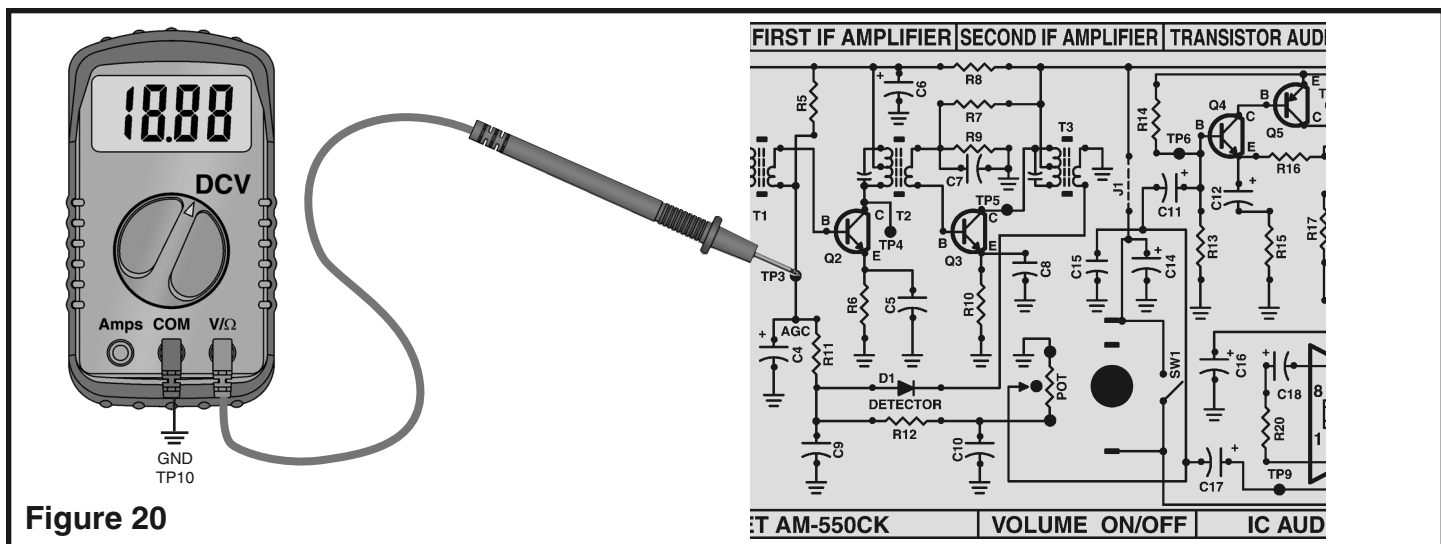

Figure 20

T3 TEST

With the power turned OFF, connect the positive lead of the VOM to TP5 and the negative lead to TP10. Make sure that the VOM is set to read 9 volts DC and turn the power ON. The voltage on the VOM should be the same

as your battery voltage or power supply voltage. If not, turn OFF the power and check that T3 is properly installed.

If you do not have an RF generator, go to Section 3.

DYNAMIC MEASUREMENTS

DETECTOR AND ACG TEST

Turn the power OFF and connect the VOM and RF generator as shown in Figure 21. Set the VOM to accurately read 2 volts DC and set the output of the RF generator for 455kHz, no modulation, and minimum amplitude. Turn the power ON and slowly increase the amplitude of the 455kHz signal from the RF generator

until the voltage at TP3 just starts to drop. This point is called the AGC threshold with no IF gain. Make a note of the amplitude setting on the RF generator here:

_____.

Turn the power OFF.

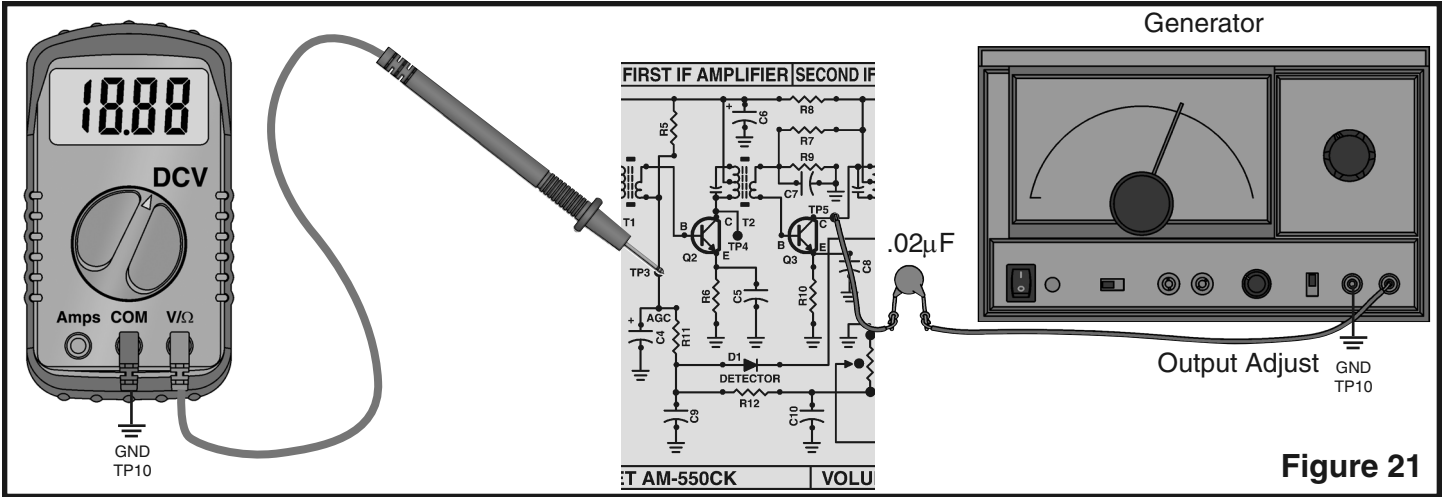

Figure 21

If your RF generator does not have amplitude modulation or you do not have an oscilloscope, go to Section 3.

SYSTEM CHECK

Connect equipment as shown in Figure 22. Set the RF generator at 455kHz, 1kHz at 80% modulation and minimum output. Turn the power ON and put the volume control at full clockwise position. Slowly

adjust the amplitude of the RF generator output until you hear the 1kHz on the speaker. If this test fails, turn the power OFF and check C11, R12, volume control, D1 and TP3.

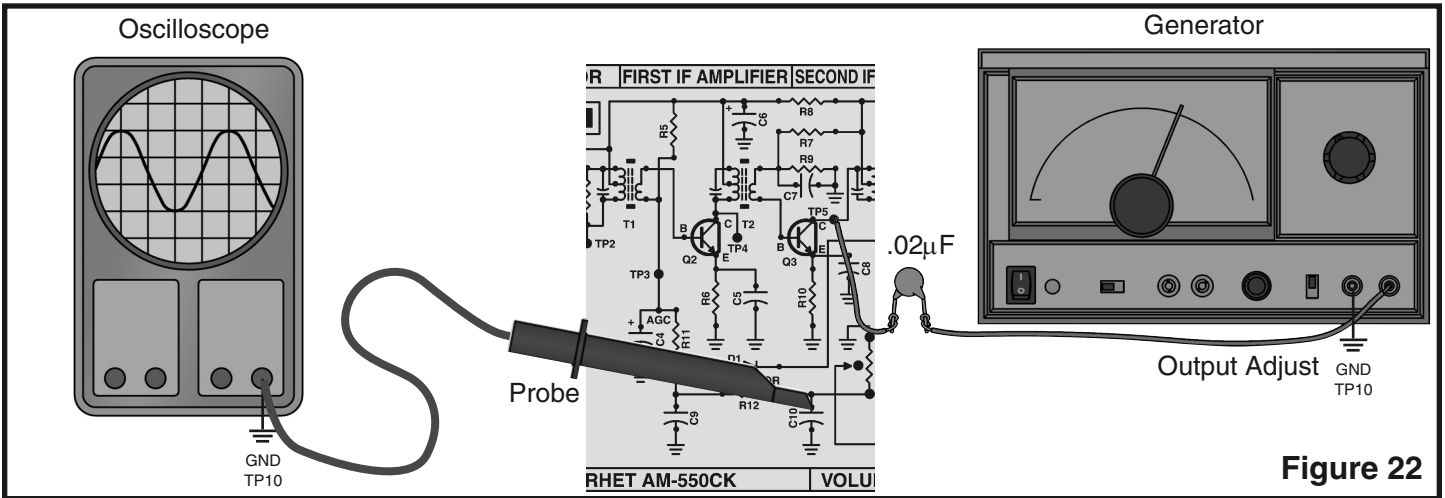

Figure 22

DETECTOR BANDWIDTH TEST

Connect equipment as shown in Figure 22. Set the RF generator at 455kHz with 80% modulation at a modulation frequency of 1kHz. Set the oscilloscope to read 0.1 volts per division. Turn the power ON and put the volume control at minimum. Increase the amplitude of the RF generator until the signal on the oscilloscope is 4 divisions peak to peak. Check the signal to make sure it is free of all distortion. Leave the frequency of the

RF output at 455kHz, but increase the modulation frequency until the output drops to 0.28 Vpp. Record the modulation frequency on the RF generator here:

_____.

This frequency should be greater than 5kHz. Turn the power OFF.

SECTION 3

SECOND IF AMPLIFIER

THEORY OF OPERATION

The purpose of the SECOND IF AMPLIFIER is to increase the amplitude of the intermediate frequency (IF) and at the same time provide SELECTIVITY. Selectivity is the ability to “pick out” one radio station while rejecting all others. The second IF transformer (T3) acts as a bandpass filter with a 3dB bandwidth of approximately 6kHz. The amplitude versus frequency response of the second IF amplifier is shown in Figure 23.

Both IF amplifiers are tuned to a frequency of 455kHz and only need to be aligned once when the radio is assembled. These amplifiers provide the majority of the gain and selectivity needed to separate the radio stations.

The gain at 455kHz in the second IF amplifier is fixed by the AC impedance of the primary side of transformer T3, and the DC current in Q3. The current in Q3 is set by resistors R7, R9 and R10. Both C7 and C8 bypass the 455kHz signal to ground, making Q3 a common emitter amplifier. The signal is coupled from the first IF amplifier to the second IF amplifier through transformer T2. The IF transformers not only supply coupling and selectivity, they also provide an impedance match between the collector of one stage and the base of the next stage. This match allows maximum power to transfer from one stage to the next.

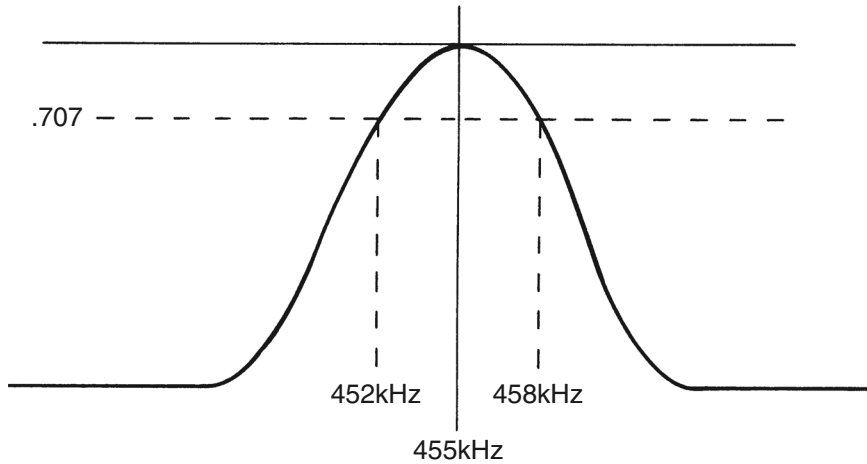
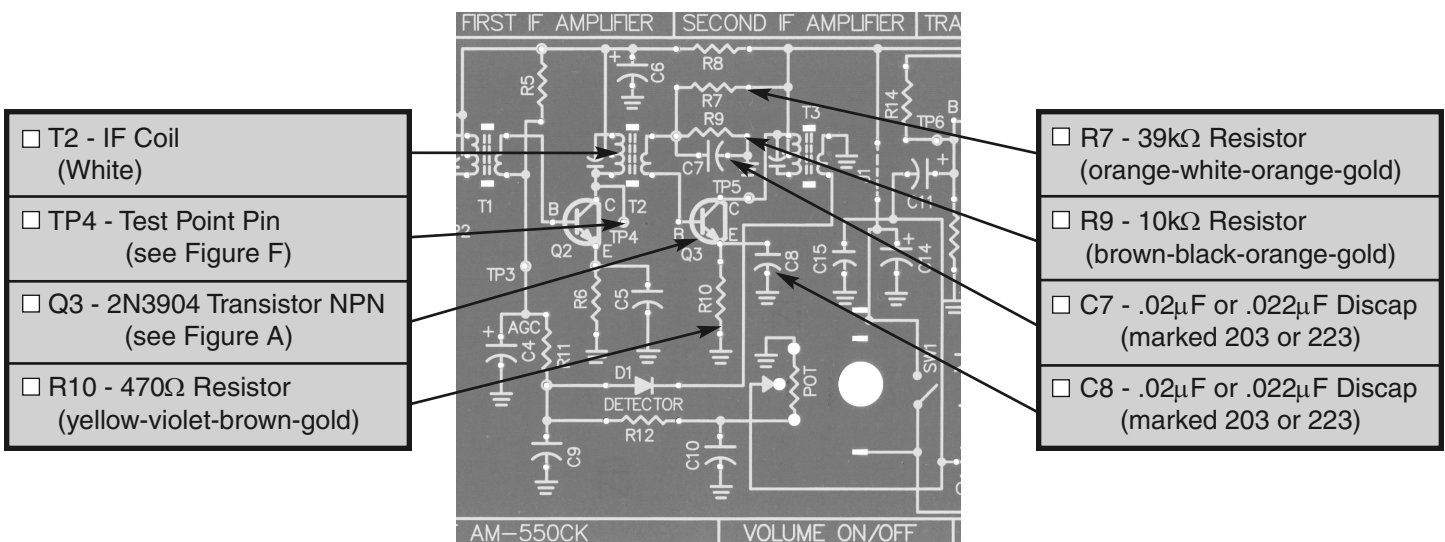

Figure 23

ASSEMBLY INSTRUCTIONS - SECOND IF AMPLIFIER



STATIC MEASUREMENTS

Q3 BIAS

With the power OFF, connect the negative lead of your VOM to any ground and the positive lead to the emitter of Q3 as shown in Figure 24. Set the VOM to read 9 volts DC and turn ON the power. The voltage at the emitter of

Q3 should be approximately 1 volt. If your reading is different by more than 0.5 volts, turn off the power and check your battery or power supply voltage. Also check components R7, R9, R10 and Q3.

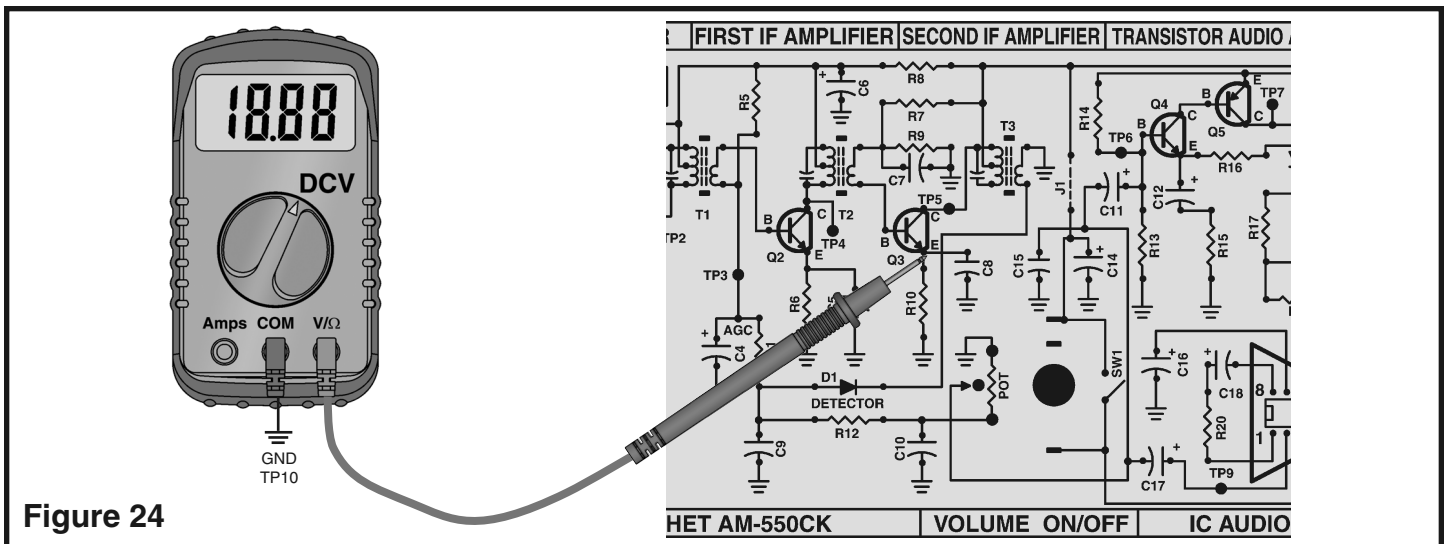

Figure 24

If you do not have an RF generator or oscilloscope, skip the following test and go to Section 4.

DYNAMIC MEASUREMENTS

AC GAIN

With the power turned OFF, connect the oscilloscope and the RF generator to the circuit as shown in Figure 25. Set the RF generator at a frequency of 455kHz, no modulation and minimum amplitude output. Set the oscilloscope vertical sensitivity at 1 volt/division. The scope probe must have an input capacitance of less than 50pF or it will detune transformer T3. Turn the power ON and slowly increase the amplitude of the RF signal until you have 4 volts peak to peak on the oscilloscope. Tune transformer T3 for a maximum output while readjusting the RF generator amplitude to keep

4Vpp at the oscilloscope. After T3 is aligned, move the scope probe tip to the base of Q3 and record the peak to peak amplitude of the signal here:

$$V_b = \text{_____} \text{ Vpp.}$$

Turn the power OFF. The AC gain of the second IF amplifier at 455kHz is equal to $4/V_b$, and should be greater than 100. If your gain is less than 100, check components C7, C8, R7, R9 and R10. Also, make sure that transistor Q3 is properly installed.

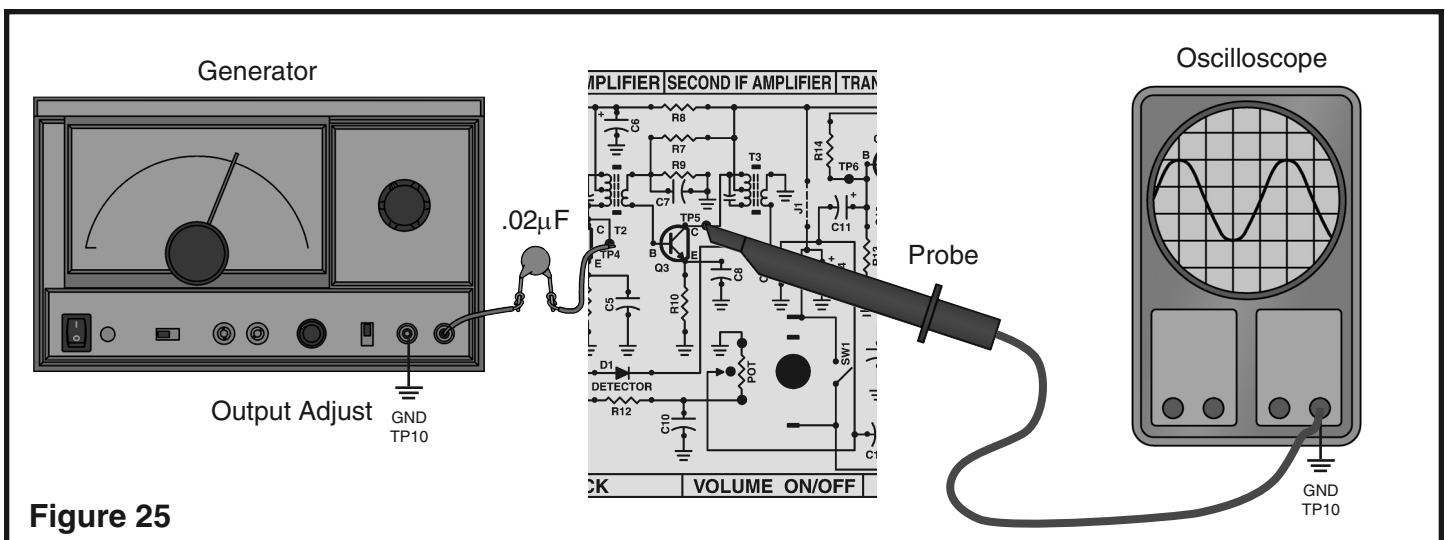

Figure 25

BANDWIDTH TEST

With the power OFF, connect your equipment as shown in Figure 26. Turn the power ON and adjust the RF generator for 0.4Vpp at the cathode of D1. If necessary, realign transformer T3 for maximum output while adjusting the output of the RF generator to maintain 0.4Vpp. Slowly decrease the frequency of the RF generator until the signal drops to 0.707 of its peaked value or 0.28Vpp. Record the frequency of the RF generator here:

FL= _____ kHz.

Now increase the frequency of the RF generator past the peak to a point where the signal drops to 0.707 of its peak value. Record that frequency point here:

FH= _____ kHz.

By subtracting the frequency of the lower 3dB corner from the frequency of the higher 3dB corner you get the BANDWIDTH of the second IF amplifier. Your results should be similar to the values shown in Figure 23.

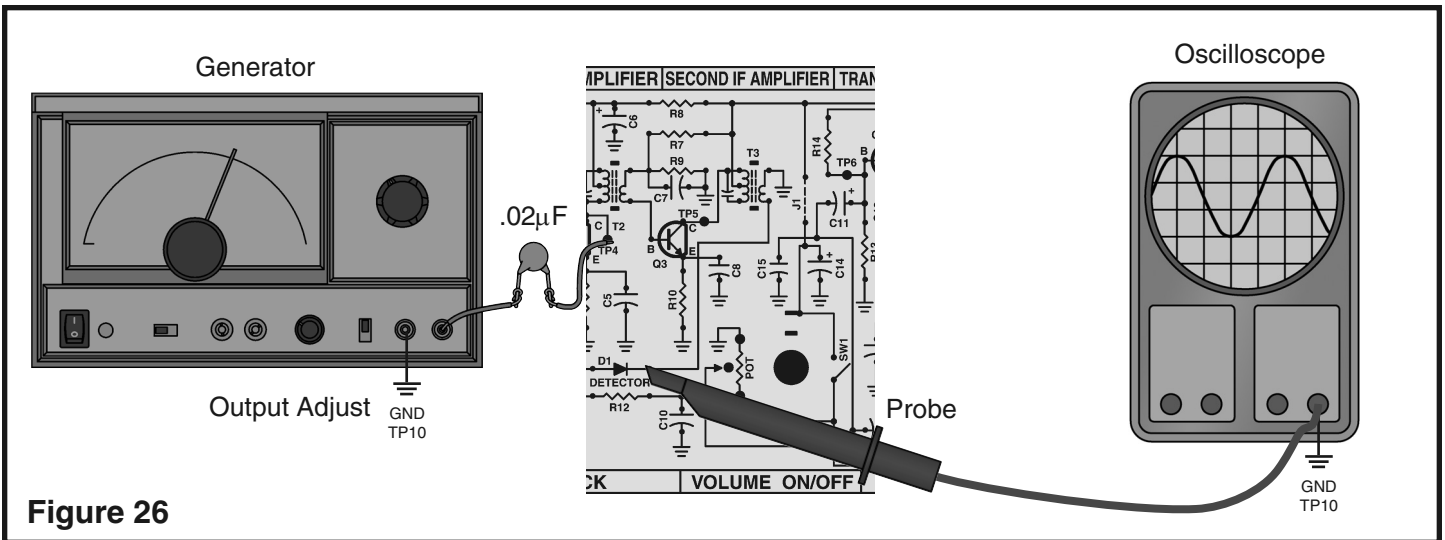

Figure 26

SECTION 4

FIRST IF AMPLIFIER

THEORY OF OPERATION

The operation of the first IF amplifier is the same as for the second IF amplifier with one important difference. The gain of the first IF amplifier decreases after the AGC threshold is passed to keep the audio output constant at the detector and prevent overload of the second IF amplifier. This is accomplished by making the voltage on the base of transistor Q2, lower as the signal strength increases. Since the voltage from base to emitter is fairly constant, the drop in voltage at the base produces a similar drop in voltage at the emitter of Q2. This drop

lowers the voltage across R6 and thus reduces the DC current through R6. Since all of the DC current from the emitter of Q2 must go through R6, the DC current in Q2 is therefore lowered. When the DC current in a transistor is lowered, its effective emitter resistance increases. The AC gain of transistor Q2 is equal to the AC collector load of Q2 divided by its effective emitter resistance. Raising the value of the effective emitter resistance thus lowers the AC gain of Q2.

ASSEMBLY INSTRUCTIONS - FIRST IF AMPLIFIER

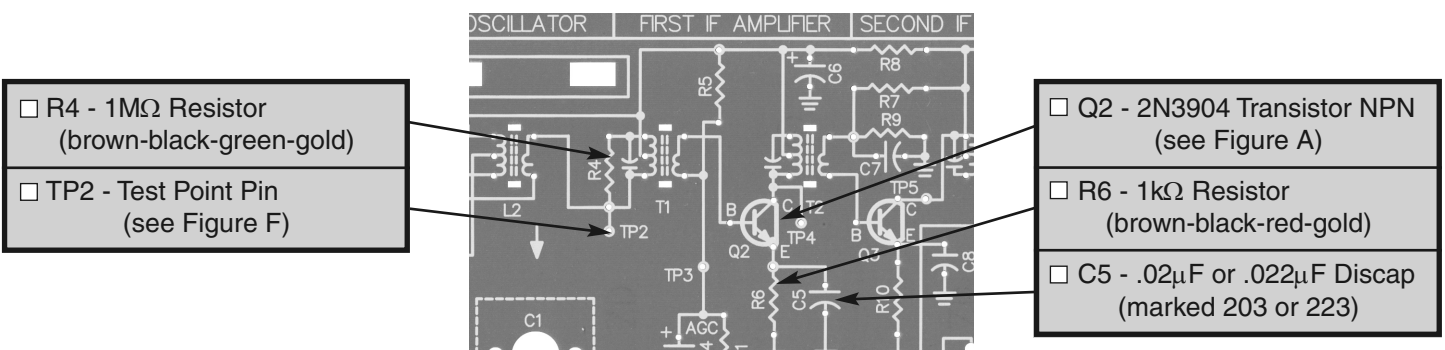

STATIC MEASUREMENTS

Q2 BASE BIAS

With the power turned OFF, reconnect your VOM to test point 3 (TP3) as shown in Figure 20. Set the VOM to read 2 volts DC accurately and turn the power ON. The

voltage should be approximately 1.5 volts. If your circuit fails this test, turn the power OFF and check Q2 and R6.

Q2 CURRENT

With the power turned OFF, connect the positive lead of the VOM to the emitter of Q2. Connect the negative lead of the VOM to TP10 and turn the power ON. The voltage

should be approximately 0.8 volts. Since the current in Q2 is equal to the current in R6, $I(Q2) = 0.8/R6$ or approximately 0.8 milliamps.

If you do not have an RF generator or oscilloscope, skip the following test and go to Section 5.

DYNAMIC MEASUREMENTS

AC GAIN

With the power turned OFF, connect the RF generator and the oscilloscope to your circuit as shown in Figure 27. Using a clip lead, short TP5 to R8 as shown in Figure 27. This short prevents the AGC from lowering the gain of the first IF amplifier. Set the RF generator to 455kHz, no modulation, and minimum amplitude output. Set the oscilloscope for a vertical sensitivity of 1 volt/division and turn the power ON. Increase the amplitude output from the RF generator until approximately 4Vpp registers on the oscilloscope. Tune the IF transformer (T2) to maximize the 455kHz at TP4. After tuning T2, adjust the RF

generator amplitude in order to keep 4Vpp at TP4. Now move the oscilloscope probe to the base of Q2 and record the peak to peak level of the 455kHz signal here:

$$V_b = \text{_____} V_{pp}$$

The AC gain of the first IF amplifier is equal to $4/V_b$. The AC gain of this amplifier should be greater than 100. DO NOT TURN THE POWER OFF. GO TO THE NEXT TEST.

AGC ACTION

Move the oscilloscope probe back to TP4 and adjust the RF generator for 4Vpp if necessary. Remove the clip

lead shorting TP5 to R8. The AGC should reduce the signal level at TP4 to approximately 0.3 volts.

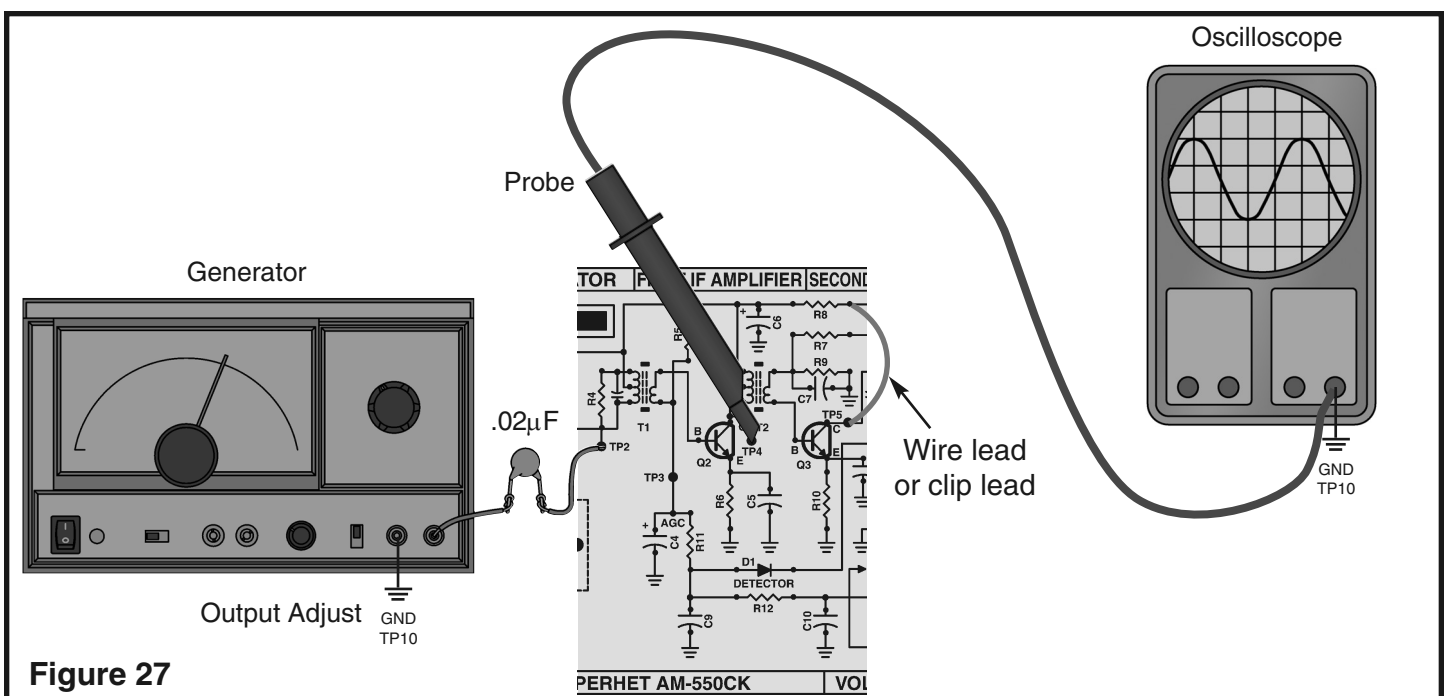

Figure 27

SECTION 5

MIXER AND OSCILLATOR

THEORY OF OPERATION

In a superheterodyne type receiver the radio wave at the antenna is amplified and then mixed with the local oscillator to produce the intermediate frequency (IF). Transistor Q1 not only amplifies the RF signal but also simultaneously oscillates at a frequency 455kHz above the desired radio station frequency. Positive feedback from the collector to the emitter of Q1 is provided by coil L2 and capacitor C3. During the heterodyne process, the following four frequencies are present at the collector of Q1.

1. The local oscillator frequency, LO.
2. The RF carrier or radio station frequency.
3. The sum of these two frequencies, LO + RF.
4. The difference of these two frequencies, LO - RF.

The “difference frequency” is used as the intermediate frequency in AM radios. The collector of Q1 also contains an IF transformer (T1) tuned only to the difference frequency. This transformer rejects all

frequencies except those near 455kHz. T1 also couples the 455kHz signal to the base of Q2 to be processed by the IF amplifiers.

The antenna and the oscillator coils are the only two resonant circuits that change when the radio is tuned for different stations. Since a radio station may exist 455kHz above the oscillator frequency, it is important that the antenna rejects this station and selects only the station 455kHz below the oscillator frequency. The frequency of the undesired station 455kHz above the oscillator is called the image frequency. If the selectivity of the antenna (Q factor) is high, the image will be reduced sufficiently.

The oscillator circuit must also change when the radio is tuned in order to remain 455kHz above the tuning of the desired radio station. The degree of accuracy in keeping the oscillator frequency exactly 455kHz above the tuning of the antenna is called tracking accuracy.

ASSEMBLY INSTRUCTIONS - ANTENNA, MIXER AND OSCILLATOR

<input type="checkbox"/> L1 - Antenna with Holders (see Figures K & L)	<input type="checkbox"/> R1 - 56kΩ Resistor (green-blue-orange-gold)
<input type="checkbox"/> C2 - .02μF or .022μF Discap (marked 203 or 223)	<input type="checkbox"/> L2 - Oscillator Coil (red)
<input type="checkbox"/> TP1 - Test Point Pin (see Figure F)	<input type="checkbox"/> Q1 - 2N3904 Transistor NPN (see Figure A)
<input type="checkbox"/> R2 - 12kΩ Resistor (brown-red-orange-gold)	<input type="checkbox"/> C3 - .01μF Capacitor (marked 103)
<input type="checkbox"/> R3 - 3.3kΩ Resistor (orange-orange-red-gold)	<input type="checkbox"/> C1 - Tuning Gang Capacitor
	<input type="checkbox"/> 2 Screws M2.5 x 3.8mm
	<input type="checkbox"/> Knob (dial)
	<input type="checkbox"/> Screw M2.5 x 8mm
	<input type="checkbox"/> Label (dial knob) (see Figure M)

Figure K

Determine if you have a three wire or four wire coil. Resistance measurements will be used to check the configuration of the coil. Slide one holder off the ferrite core of the antenna assembly. Then slide the coil off the the ferrite core. Measure the resistance of the coil. Your readings should match the approximate values as shown.

Note: If the end of a wire from the antenna should break off, strip the insulation off the end with a hot soldering iron. Lay the wire down on a hard surface and stroke the wire with your iron. The insulation should come off very easily. **CAUTION:** The soldering iron will burn the hard surface that you are working on.

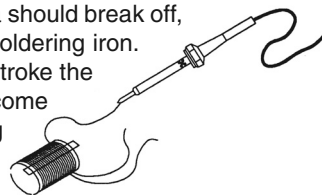

3 Wire

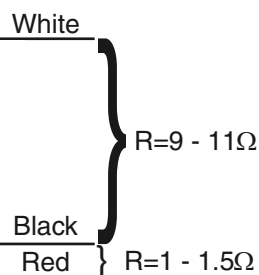

4 Wire

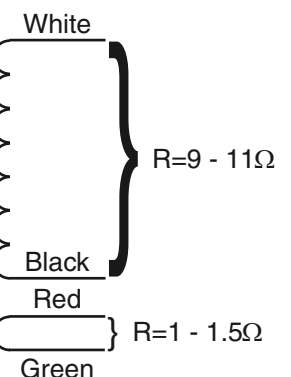

Assemble it to the PC board as shown below. Mount the antenna assembly to the PC board.

- Put the tab of the first holder into the right hole and twist the tab 90°.
- Put the tab of the second holder into the left hole and twist the tab 90°.
- Slide the ferrite core through the holders.
- Slide the antenna coil through the ferrite core.

Note: If the end of a wire from the antenna should break off, strip the insulation off the end with a hot soldering iron. Lay the wire down on a hard surface and stroke the wire with your iron. The insulation should come off very easily.

CAUTION: The soldering iron will burn the hard surface that you are working on.

3 Wire Type Antenna

Solder the 3 colored wires to the PC board.

- Wire A (red) to the hole marked "3".
- Wire B (black) to the hole marked "2".
- Wire C (white) to the hole marked "1".

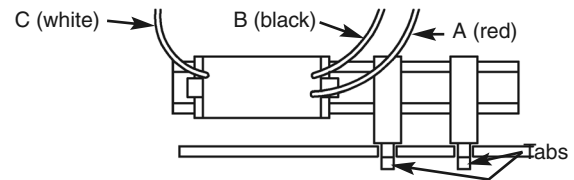

4 Wire Type Antenna

Solder the 4 colored wires to the PC board.

- Wire A (green) to the hole marked "3".
- Wire B (red and black twisted together) to the hole marked "2".
- Wire C (white) to the hole marked "1".

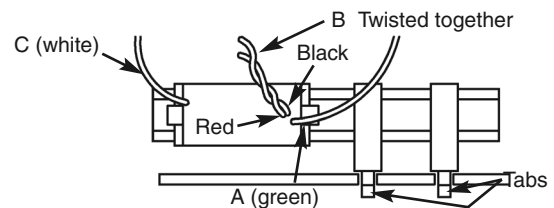

OR

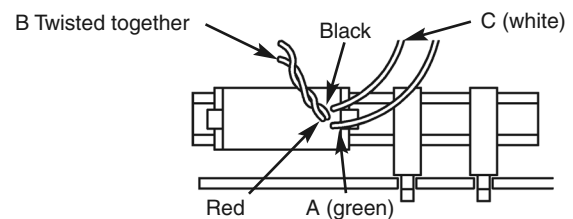

Punch out one antenna shim from the front flap of the box.

Insert the cardboard antenna shim between the ferrite core and the antenna coil. This will temporarily hold the coil in place.

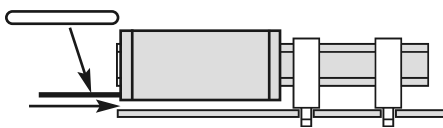

Figure L

Your kit may contain a 3 lead or a 4 lead capacitor. Bend the leads as shown. Fasten C1 into place on the top side of the PC board with two M2.5 x 3.8mm screws.

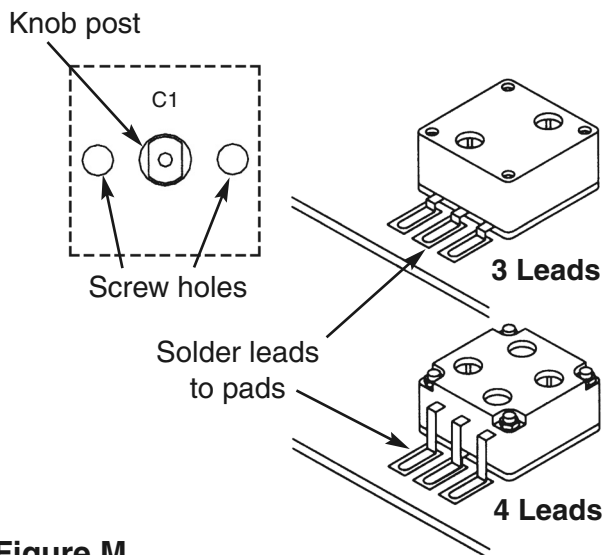
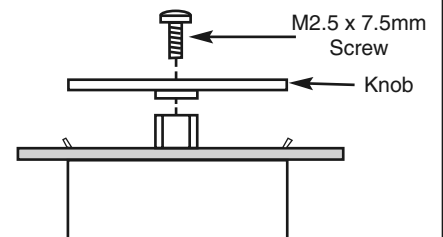
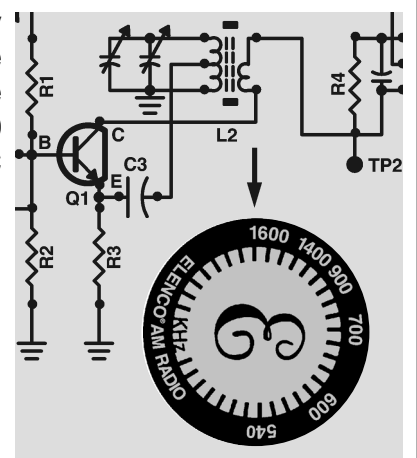

Figure M

Fasten the knob to the shaft of the capacitor with one M2.5 x 7.5mm screw.



Turn the dial fully clockwise. Remove the protective backing from the label and align the 1600 with the arrow on the PC board.



PC Board Stand

Insert the PC board into the stand as shown.

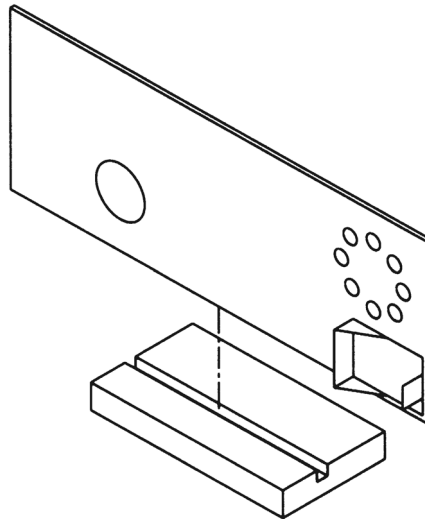

Figure N

STATIC MEASUREMENTS

Q1 BIAS

With the power turned OFF, connect the VOM to your circuit as shown in Figure 28. Connect a clip lead from test point two (TP2) to the collector of Q1. This short prevents Q1 from oscillating. Set the VOM to read 2 volts DC accurately and turn the power ON. The DC voltage at

TP1 should be 1.6 volts. If the voltage in your circuit differs by more than 0.5 volts, leave the power ON and check the battery voltage. If the battery voltage is greater than 8.5 volts, turn the power OFF and check components R1, R2, R3 and Q1.

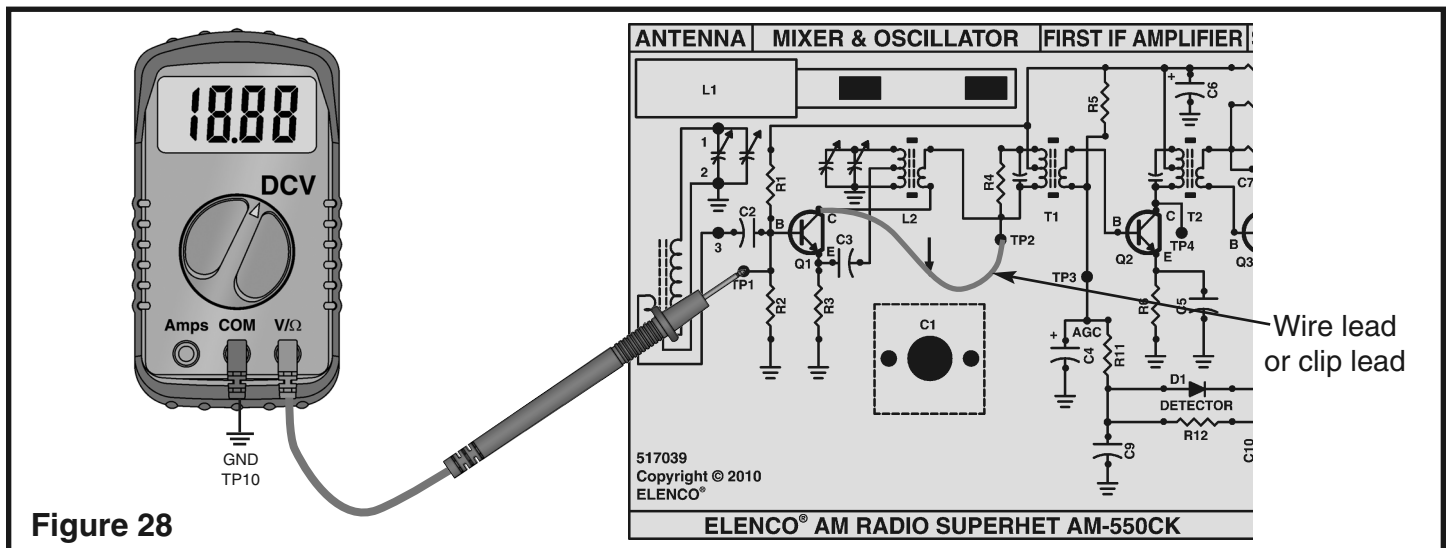

If you do not have an oscilloscope, go to the Final Alignments With No Test Equipment Section.

DYNAMIC MEASUREMENTS

OSCILLATOR CIRCUIT

With the power turned OFF, connect the oscilloscope to the circuit as shown in Figure 29. Set the oscilloscope for a vertical sensitivity of 1 volt/division and turn the power ON. The oscilloscope should display a low voltage sine

wave. The frequency of the sine wave should change when capacitor C1 is turned. If your circuit fails this test, turn the power OFF and check components Q1, C1, C2, C3, L1 and L2.

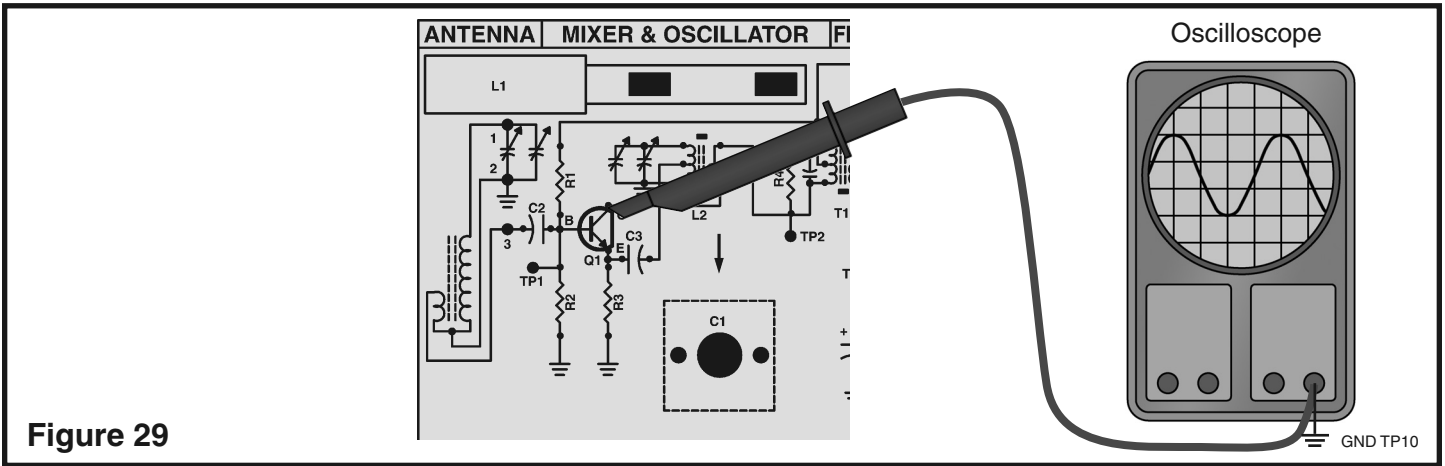

Figure 29

If you do not have an RF generator, go to the Final Alignments with No Test Equipment Section.

FINAL ALIGNMENTS

IF BANDWIDTH

With the power turned OFF, connect the RF generator and the oscilloscope to your circuit as shown in Figure 30. Short TP2 to the collector of Q1 with a clip lead to “kill” the local oscillator. Set the RF generator at a frequency of 455kHz, modulation of 400Hz 80%, minimum amplitude output. Set the oscilloscope to read 0.1Vpp and turn the power ON. Increase the amplitude of the RF signal until the oscilloscope registers 0.5Vpp. Align transformers T3, T2 and T1 for the maximum AC reading on the oscilloscope. Decrease the amplitude of the signal from the RF generator to restore 0.5Vpp on the oscilloscope. Repeat the last two steps until no change in the peak at the oscilloscope is noticed.

After IF alignment, lower the frequency from the RF generator until the reading on the VOM drops to 0.707 of its peaked value. Record the frequency of this lower 3dB corner here:

$$F_l = \text{_____ kHz.}$$

Increase the RF generator frequency past the peak to the upper 3dB corner and record that frequency here:

$$F_h = \text{_____ kHz.}$$

The bandwidth of the IF amplifiers is $BW = F_h - F_l$. IF bandwidth should be between 1 to 2kHz. This bandwidth will widen as the AGC is approached.

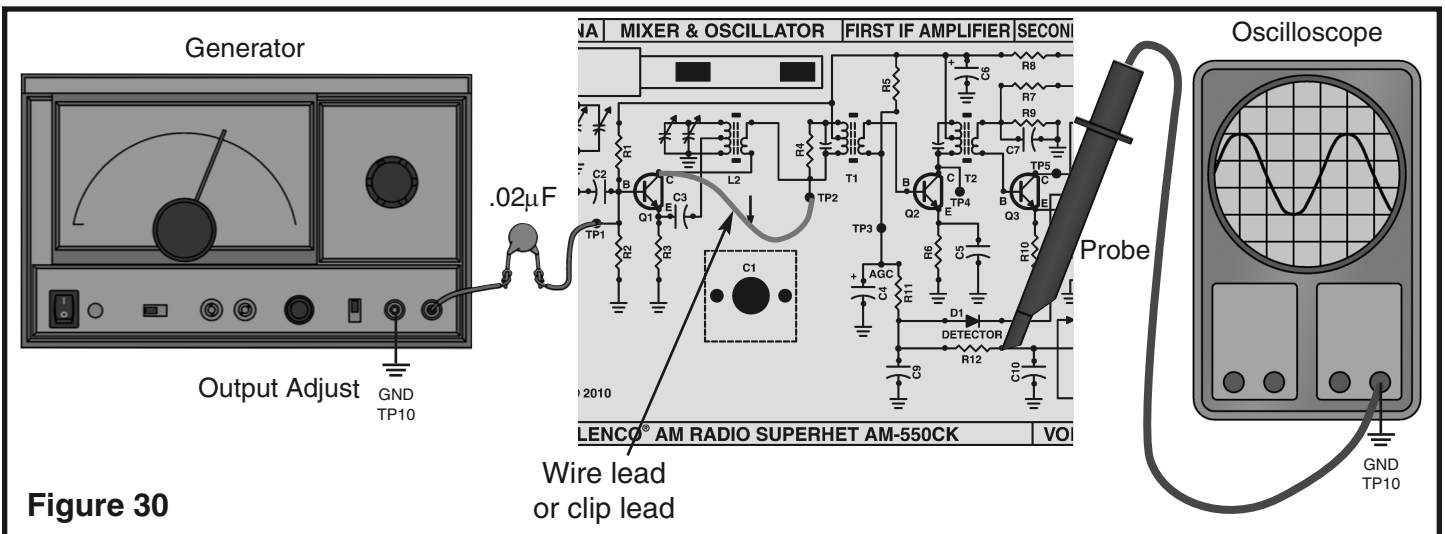

Figure 30

SETTING OSCILLATOR RANGE

With the power turned OFF, connect the equipment to the circuit as shown in Figure 30. DO NOT connect the clip lead from TP2 to Q1. Set the RF generator at 540kHz, 400Hz 80% modulation, and a low level of output. Turn the tuning capacitor fully counter-clockwise. Turn the power ON and a 400Hz tone should be heard coming from the speaker. Tune the oscillator coil (L2) for a peak on the oscilloscope. Adjust the RF generator output during this process to maintain a peak at 0.5Vpp or less. After peaking L2, set the RF generator frequency to 1600kHz and turn the tuning capacitor (C1) fully clockwise. A 400Hz tone should be heard coming from the speaker. Tune the oscillator trimmer capacitor on the back of C1 for a peak on the oscilloscope (see Figure 31).

After peaking the oscillator trimmer capacitor, return the RF generator to 540kHz, and capacitor C1 to the fully counter-clockwise position and readjust L2. Repeat the last few steps until both settings of the oscillator are correct. This process sets the oscillator range at 995kHz to 2055kHz. If a frequency counter is available, you may

ANTENNA ALIGNMENT

With the power turned OFF, connect test equipment to your circuit as shown in Figure 32. Set the RF generator at 600kHz, 400Hz 80% modulation, moderate signal strength. Set the oscilloscope to read 0.5Vpp and turn the power ON. Turn C1 fully counter-clockwise, then slowly turn C1 clockwise until a 400Hz tone can be heard coming from the speaker. Slowly slide the antenna coil back and forth on the ferrite rod to obtain a peak on the oscilloscope. For maximum signal, your location of the antenna coil may have to be on the end of the ferrite rod (as shown in Figure 33). Change the frequency of the RF generator to 1400kHz

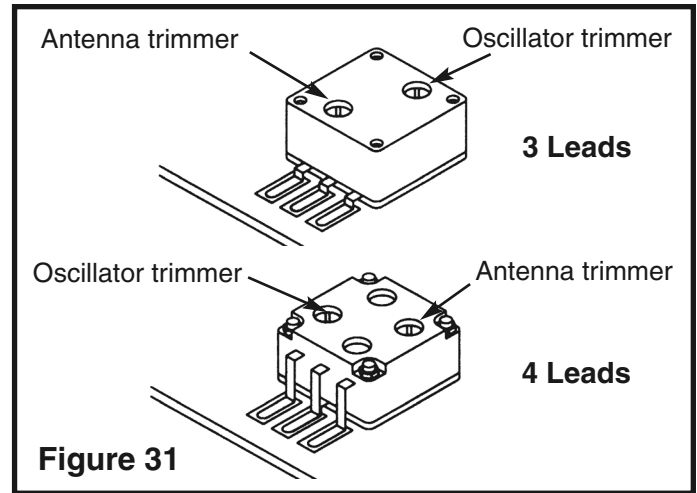

Figure 31

verify this alignment by measuring the frequency at the emitter of Q1 for both ends of the tuning capacitor (C1). Be careful not to mistune the oscillator during this measurement. A coupling capacitor of 82 picofarads or less to the frequency counter is recommended.

and adjust C1 until a 400Hz tone can be heard coming from the speaker. Carefully peak the reading on the oscilloscope by adjusting the frequency of the RF generator. Now tune the antenna coil to this frequency by adjusting the antenna trimmer on the back of C1 (see Figure 31). This process should be repeated until both settings of the antenna track the oscillator tuning. Once the antenna is properly aligned, carefully apply candle wax or glue to the antenna coil and ferrite rod (as shown in Figure 33).

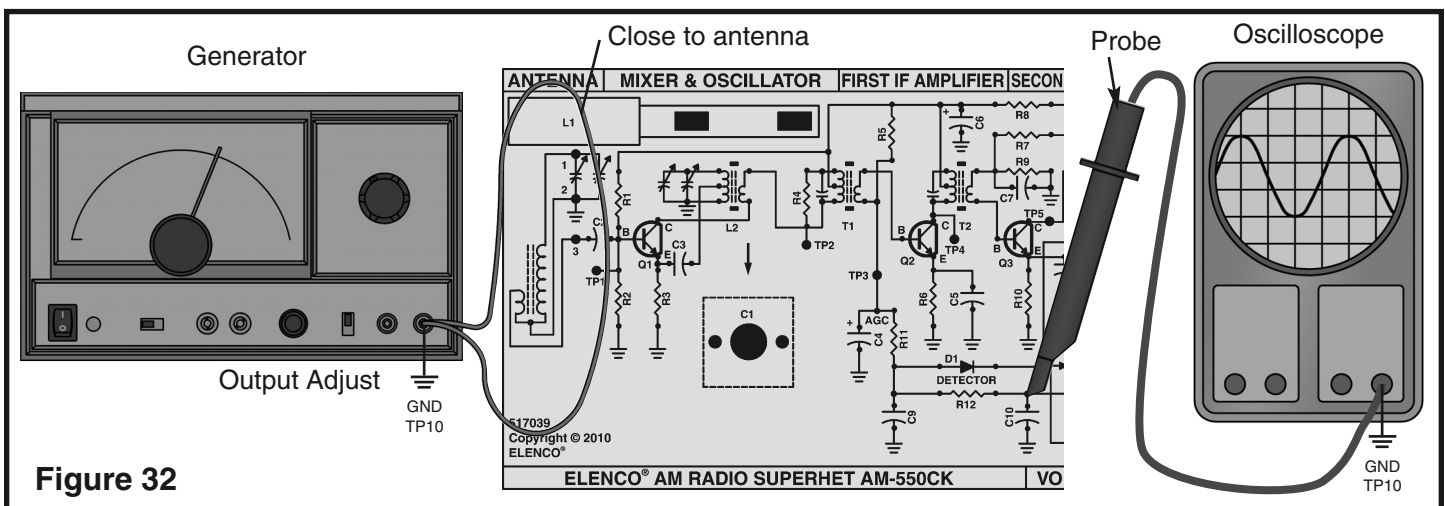

Figure 32

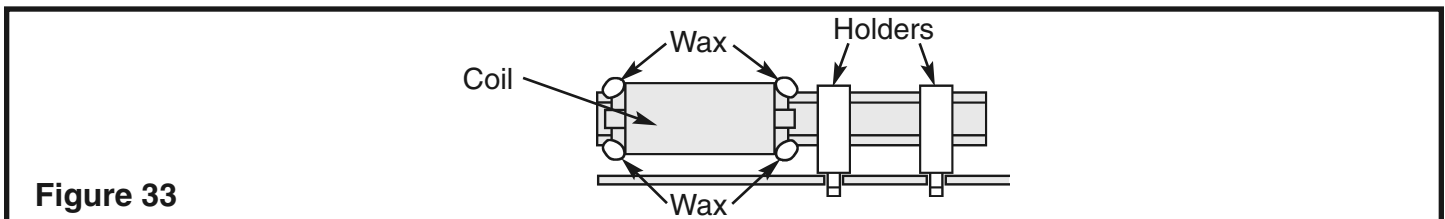

Figure 33

AM ALIGNMENT WITH NO TEST EQUIPMENT

It is best to use an earphone for this alignment procedure. Rotate the tuning knob fully counter-clockwise and place the label on the knob with the white arrow pointing at the 540kHz marking.

With an alignment tool or screwdriver, turn coils L2, T1, T2 and T3 fully counter-clockwise until they stop. DO NOT FORCE THE COILS ANY FURTHER. Turn each coil in about 1¼ to 1½ turns. Set the antenna coil about 1/8" from the end of its ferrite rod. Refer to Figure L on page 29.

Turn the power ON and adjust the volume to a comfortable level. Tune the dial until a weak station is heard. If no stations are present, carefully slide the antenna back and forth on its ferrite rod and retune the dial if necessary. With an alignment tool or screwdriver, adjust T1 until the station is at its loudest. Reduce the volume control if necessary. Adjust T2 until the station is at its loudest and reduce the volume control if necessary. Adjust T3 until the station is at its loudest and reduce the volume if necessary. Retune the radio for another weak station and repeat this procedure until there is no more improvement noticed on the weakest possible station. This procedure peaked the IF amplifiers to their maximum gain.

Tune the radio until a known station around 600kHz is found. It may be necessary to listen to the station until

their broadcast frequency is announced. If no stations are present at the low side of the AM band, adjust L2 until a station is heard. Once a station is found and its broadcast frequency is known, rotate the dial until the white pointer is aligned with that station's frequency marking on the dial. Adjust L2 until the station is heard. Tune the radio until a station around 1400kHz is heard. It may be necessary to listen to the station until their broadcast frequency is announced. If no stations are present at the high end of the AM band, adjust the oscillator trimmer on the back of the gang. Once a station is found and its broadcast frequency is known, rotate the dial until the white pointer is aligned with that station's frequency marking on the dial. Adjust the oscillator trimmer located on the back of the gang until a station is heard. Repeat these steps until the oscillator alignment is optimized. This procedure set the oscillator range at 995kHz to 2055kHz.

Tune the radio for a station around 600kHz. Carefully slide the antenna back and forth until the station is at its loudest. Tune the radio for a station around 1400kHz. Adjust the antenna trimmer located on the back of the gang until the station is at its loudest. Repeat these steps until the antenna alignment is optimized. This procedure set the antenna to "track" the oscillator. Once the antenna is properly aligned, carefully apply candle wax or glue the antenna coil to the ferrite rod to prevent it from moving (as shown in Figure 33).

DC Voltages

The voltage readings below should be used in troubleshooting the AM radio. Measure the voltage on transistors Q4 - Q6 with switch SW2 in the top position. When measuring the voltage on the IC, make sure the switch SW2 is in the down position.

Q1 B 1.5V E 1.0V C 8.9V	Q6 B 5.8V E 5.2V C 9.0V
Q2 B 1.4V E 0.7V C 8.9V	Q7 B 4.6V E 5.2V C 0.0V
Q3 B 1.7V E 1.0V C 9.0V	U1 1 - 1.3V 2 - 0 3 - 0 4 - 0 5 - 4.5V 6 - 9V 7 - 4.6V 8 - 1.3V
Q4 B 5.7V E 5.2V C 8.3V	
Q5 B 8.3V E 9.0V C 5.8V	

Test Conditions

1. Volume control set to minimum.
2. Connect a jumper wire between capacitor C2 (side that goes to red lead of coil L1) to negative battery.
3. Battery voltage: 9.0V
4. All voltages are referenced to circuit common.
5. Voltage reading can vary $\pm 10\%$.



AM-550CK RADIO BAFFLE

NOTICE: Keep the box the kit came in. After you have completed the radio and it operates satisfactorily, you may want to install a baffle to improve the sound.

The final step in the radio kit will be to assemble and attach a baffle to the speaker. You will need to remove the baffle located in the bottom of the box. If it does not want to come out easily, use a knife to cut the holding tabs.

When a speaker is not enclosed, sound waves can travel in all directions. As a speaker moves outward, it creates positive pressure on the air in front of it and negative pressure on the rear. At low frequencies, out of phase front and rear waves mix causing partial or total cancellation of the sound wave. The end result is a speaker less efficient and distorted.

To eliminate the low frequency cancellation, a speaker is placed inside an enclosure. Now the front sound waves are prevented from traveling to the back. The speaker will now compress and decompress air inside, increasing its resonant frequency and Q relative to the free air values. This type of effectively air-tight box is called an Acoustic Suspension.

- Screw M1.8 x 7.5mm
- Nut M1.8
- Baffle

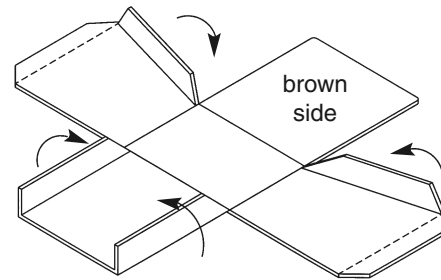
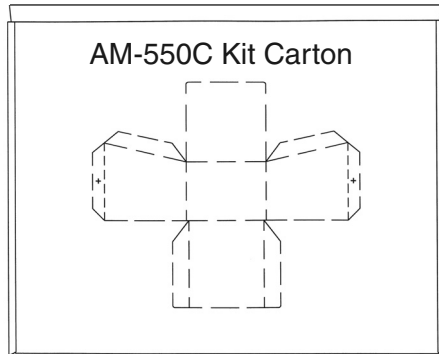

2. Bend the four flaps upward as shown.

1. Start at one edge and carefully remove the baffle from the bottom of the kit box.

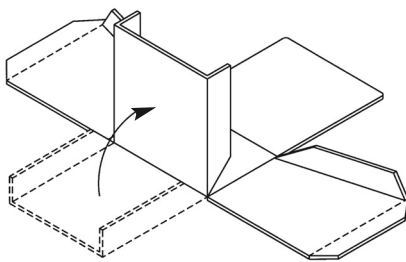

3. Bend the top side upward as shown.

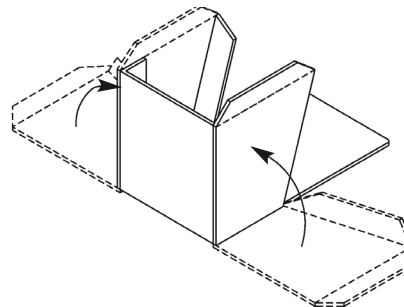

4. Bend the two sides upward. Attach the three sides using scotch tape or glue (Elmer's, Duco Cement, or other).

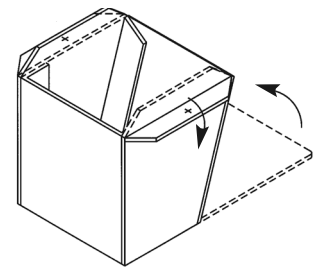

5. Bend the bottom side upward and attach it to the other sides using scotch tape or glue. Bend the two mounting flaps as shown.

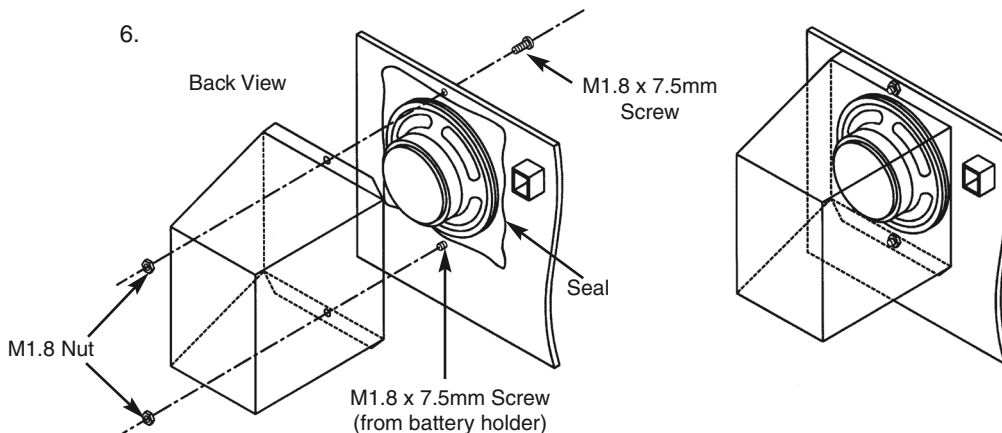

Remove the nut from the top M1.8 x 7.5mm screw. Insert the baffle as shown in Step 6. Insert an M1.8 x 7.5mm screw and fasten down the baffle with two M1.8 nuts as shown in Step 6.

Optional: To make an air tight seal, place a bead of seal between the PC board and the baffle.

SCHEMATIC DIAGRAM

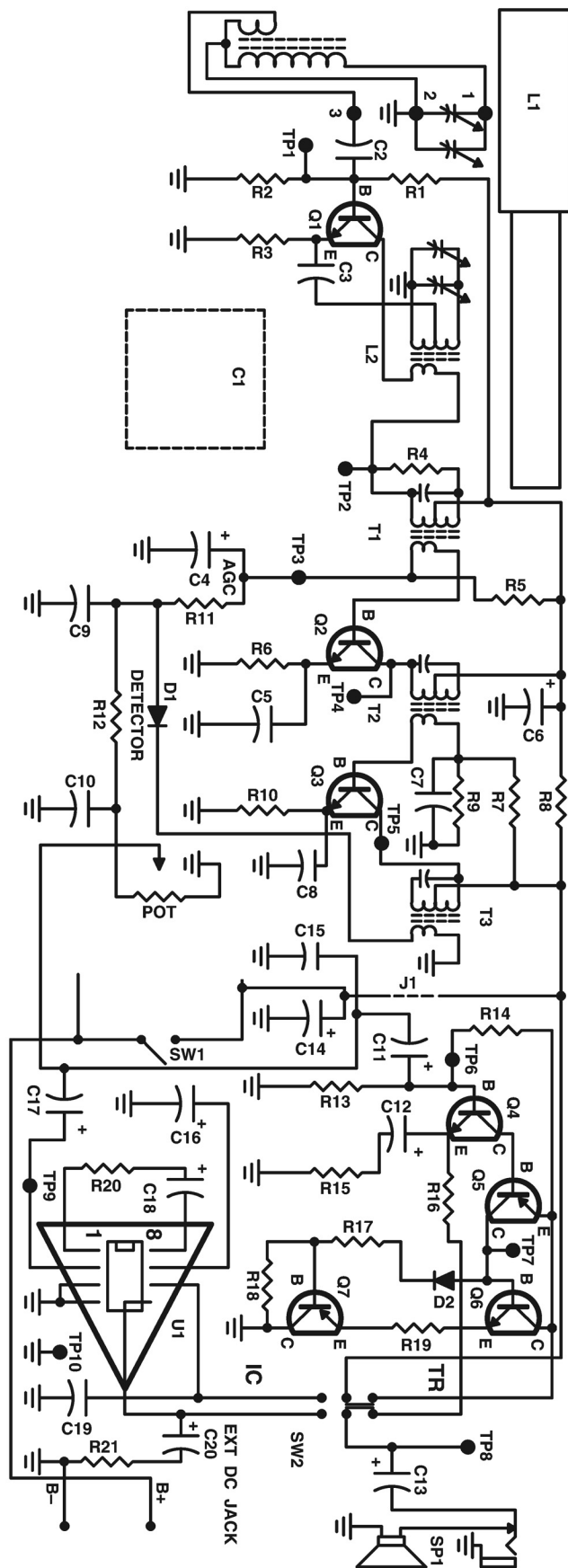

ELENCO®

150 Carpenter Avenue • Wheeling, IL 60090
 (847) 541-3800 • Website: www.elenco.com • e-mail: elenco@elenco.com