

SMT - TRAINING COURSE

MODEL SM-200K



7 56619 00059 6

Surface Mount Technology Kit

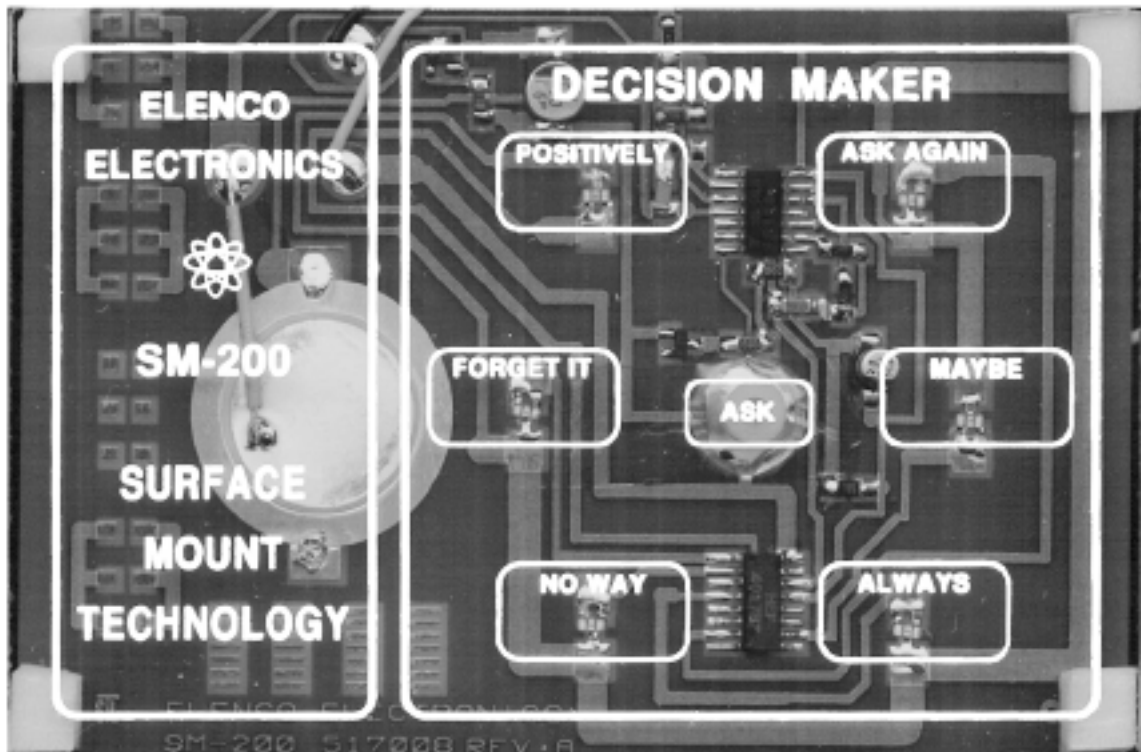

Assembly and Instruction Manual

Elenco™ Electronics, Inc.

PARTS LIST

If you are a student, and any parts are missing or damaged, please see instructor or bookstore.
 If you purchased this decision maker kit from a distributor, catalog, etc., please contact Elenco™ Electronics (address/phone/e-mail is at the back of this manual) for additional assistance, if needed.

RESISTORS

Qty	Symbol	Value	Marking	Part #
□ 6	J1,J2, P1-P4	0Ω	0	196101
□ 2	R7,R8	470Ω 5% 1/8W	471	196344
□ 1	R5	10kΩ 5% 1/8W	103	196514
□ 1	R1	15kΩ 5% 1/8W	153	196518
□ 1	R4	56kΩ 5% 1/8W	563	196556
□ 1	R3	100kΩ 5% 1/8W	104	196614
□ 2	R2,R6	1.5MΩ 5% 1/8W	155 / 1504	196758

CAPACITORS

Qty	Symbol	Value	Description	Part #
□ 1	C2	.0039μF 10% 50V	Cap. chip	233997
□ 1	C1	.015μF 10% 50V	Cap. chip	241597
□ 1	C4	2.2μF 20% 10V	Electrolytic (Lytic)	262220
□ 1	C3	100μF 20% 10V	Electrolytic (Lytic)	281020

SEMICONDUCTORS

Qty	Symbol	Value	Description	Part #
□ 1	D1	1N4148 SM	Diode RA6J, A6, A2, or 5H	31BA16
□ 1	Q1	3904	Transistor RIA, 1A, N71, 1AM, or KINC	32SM04
□ 1	IC1	4011	4011 Integrated Circuit (IC)	33SM11
□ 1	IC2	4017	4017 Integrated Circuit (IC)	33SM17
□ 6	LED1-LED6	LTL907	Light Emitting Diode (LED)	350907

MISCELLANEOUS

Qty	Description	Part #	Qty	Description	Part #
□ 1	PC Board	517008	□ 1	Filter red	621424
□ 1	Dimple switch	546101	□ 1	Spacer 7/32"	624008
□ 24"	Solder	551124	□ 1"	Tape double sided	748127
□ 1	Battery snap	590098	□ 1"	Cushion tape	790006
□ 1	Buzzer	595201	□ 1"	Wire red #22 solid	814220

PARTS IDENTIFICATION

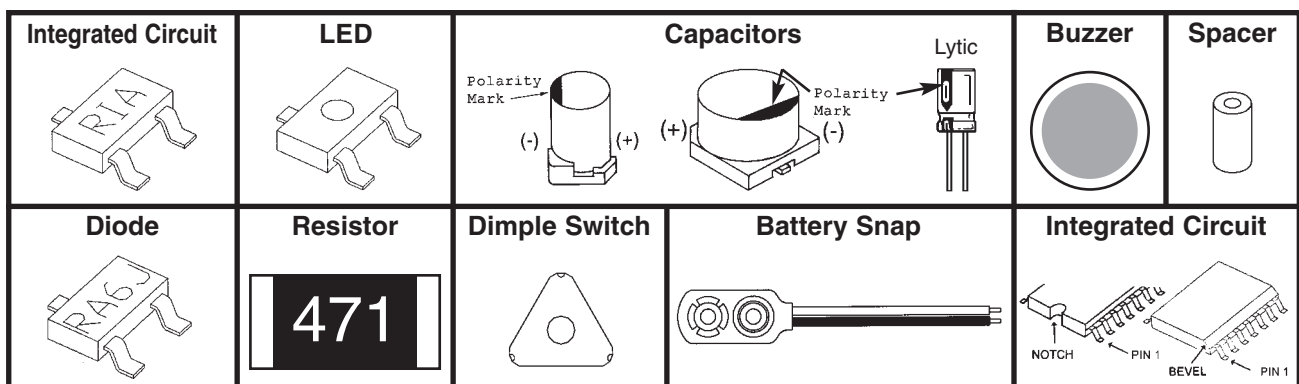

INTRODUCTION

Need help in making up your mind? Just ask the SM-200K Decision Maker. Press the ask button and the right answer will be given to your question. The Decision Maker has six light emitting diodes (LEDs) that are driven ON and OFF one at a time in sequence. When the ASK button is pushed the LEDs will flash and the buzzer will sound. After a brief period of time only one LED will remain lit. Above the lit LED is the answer to the question asked. In a minute or two the LED will get dim and gradually go out.

The SM-200K uses very small surface mounted components. By building this kit you will obtain an interesting electronic device and also gain valuable experience in surface mount technology.

THEORY OF OPERATION

Figure 1 shows the block diagram of the Decision Maker circuit. It consists of 6 LEDs driven by a decimal counter and two oscillators. One oscillator drives the decimal counter and the other drives a buzzer. The counter and the oscillators are controlled by two timers. We shall proceed to study the circuit in detail.

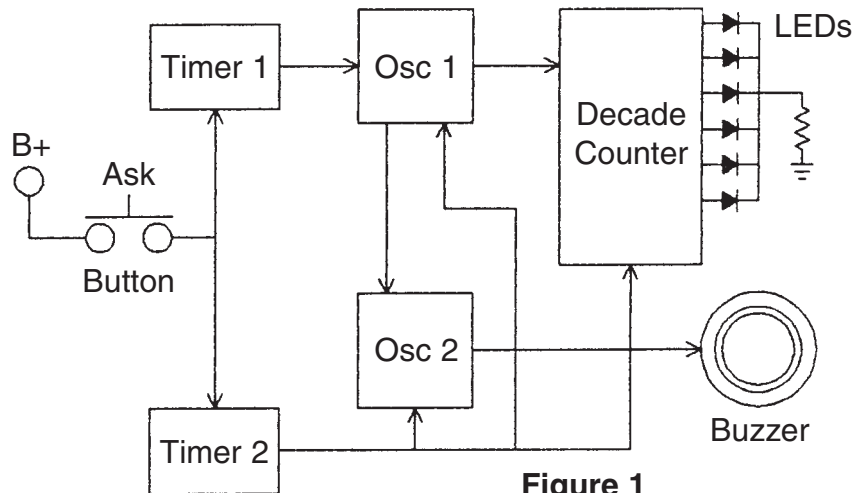

Figure 1

DECADE COUNTER

The 4017 IC is a 5 stage divide by 10 counter. Figure 2 shows a diagram of the IC. The IC has 10 outputs and a clear input. Only one of the 10 outputs will be high at any given time. The other 9 will be low. Let us assume that output 1 is high. If a pulse is fed to the clock input, output 1 will go low and output 2 will go high. Each clock pulse will move the output one position. If we connect an LED to the output, it will light only when the output goes high. It is obvious that when the clock is running, the LEDs will flash ON and OFF with the speed of the clock. When the clock stops only one LED will be lit.

In this design 6 LEDs are used per IC. But the counter has 10 outputs. If the clock stops at an output without an LED, nothing will light. To prevent this the 4017 IC is preset after hitting the 6th output. This is done by tying the 7th output to the clear pin (pin 5 and pin 15 shorted together).

Block Diagram

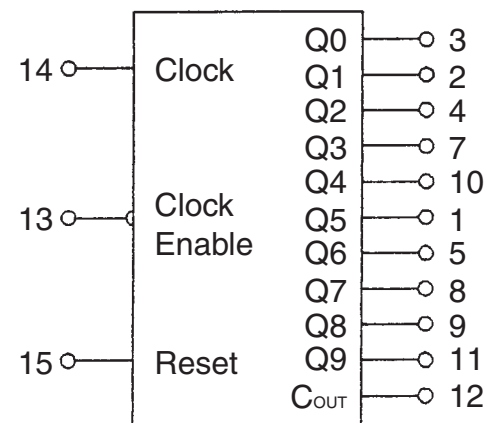

V_{DD} = Pin 16

V_{SS} = Pin 8

Figure 2

LIGHT EMITTING DIODES (LED)

The operation of the LED is very simple. When current flows through the LED it will emit light. Note that the LED is connected between an IC output and ground through a resistor. When the IC output goes high the LED will light. The resistor limits the current so that the LED will not be damaged.

OSCILLATORS

The SM-200K uses two oscillators. The first oscillator produces a frequency of about 2000 hertz (cycles per second) and the other produces a frequency of about 20 hertz. Figure 3 shows the basic oscillator circuit. The 4011 integrated circuit (IC) contains four two input NAND gates. Two of these NAND gates are needed to form an oscillator. Feedback for this oscillator is via capacitor C1 and resistors R1 and R2. These elements determine the frequency of oscillation. Both IC1 and IC2 act as inverters, that is when the input is low the output is high. As long as pin 1 of IC1 is high the circuit will oscillate. If pin 1 is brought low, the circuit will stop oscillating.

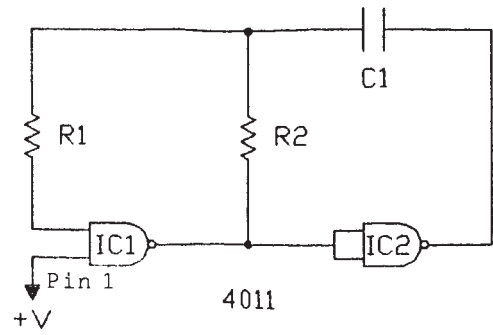

Figure 3



Figure 4

The second oscillator is similar to the one described except for a difference in its frequency controlling components, capacitor C2 and resistors R3 and R4. C2 and R4 are smaller values causing the oscillator to oscillate at a much higher frequency. Pin 8 of the first NAND gate is brought high at a 20 cycle rate. This causes the second oscillation to be chopped up at the first oscillation frequency rate as shown in Figure 4. This combination produces the unusual sound heard from the buzzer.

BUZZER

The SM-200K buzzer consists of a piezoelectric material on a metal base. When a voltage is applied to a piezoelectric material its dimensions change. The buzzer is connected to the 2kHz oscillator. When the oscillator runs, the changing dimensions of the piezoelectric buzzer act like the cone of a speaker to set up sound waves.

TIMERS

Timer 1 is made up of capacitor C4 and resistor R6. Timer 2 is made up of capacitor C3 and resistor R5 (see schematic diagram). When switch S1 is pushed both capacitors charge up to 9 volts and the oscillators run. When the switch is released, capacitor C4 discharges through resistor R6 and capacitor C3 discharges through resistor R5 and the base of Q1.

Note that C4 is tied to pin 1 of the 4011 IC. Thus, when capacitor C4 loses its charge, the circuit stops oscillating. The buzzer stops and a single LED remains lit. After a minute or two, C3 loses its charge and removes the base current from Q1. Q1 is in the ground return path of the LEDs and both ICs. Thus, when Q1 is turned off, the LED goes out. Only a very small leakage current is then drawn from the battery. This current is so small that no ON/OFF switch is required.

ASSEMBLY INSTRUCTIONS

INTRODUCTION

Assembly of your SM-200K Decision Maker will prove to be an exciting project and give much satisfaction and personal achievement. If you have experience in soldering and wiring technique you should have no problem in the assembly of this kit. Care must be given to identifying the proper components and in good soldering habits. Above all, take your time and follow the easy step by step instructions. Remember, "An ounce of prevention is worth a pound of cure". Avoid making mistakes and no problems will occur.

PARTS VERIFICATION

Before beginning the assembly process, familiarize yourself with the components and this instruction book. Verify that all parts are present. This is best done by checking off each item against the parts list.

Care must be taken when handling the chip resistors and capacitors. They are very small and are easily lost. Chip resistors are marked with their component value. The first 2 digits are the first 2 digits of the resistance in ohms. The last digit gives the number of zeros following the first 2 digits. The resistor shown at right is therefore 3,900 ohms.

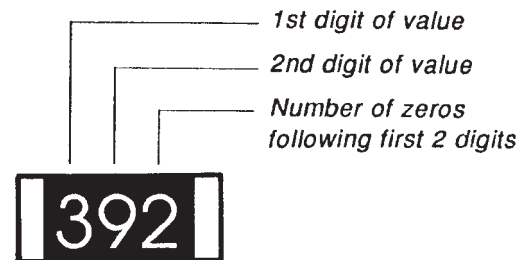

The values of the chip capacitors are not marked on the component. The two capacitors, .0039 μ F and .015 μ F, are each in a separate bag with the component value marked on the bag. To avoid mixing these parts up, they should not be taken out of their packages until just before they are soldered to the PC board. Sometimes these parts are mixed, but can be identified by different color and quantities.

SAFETY PROCEDURES

- Wear eye protection when soldering.
- Locate soldering iron in an area where you do not have to go around it or reach over it.
- **Do not hold solder in your mouth.** Solder contains lead and is a toxic substance. Wash your hands thoroughly after handling solder.
- Be sure that there is adequate ventilation present.

SOLDERING TIPS

The most important factor in assembling your SM-200K Decision Maker is good soldering techniques. Using the proper soldering iron is of prime importance. A small pencil type iron of 10-15 watts is recommended. A sharply pointed tip is essential when soldering surface mount components. The tip of the iron should be kept clean and well tinned at all times. Many areas on the printed circuit board are close together and care must be given not to form solder shorts. Solder shorts may occur if you accidentally touch an adjacent foil, particularly a previously soldered connection, using too much solder, or dragging the iron across adjacent foils. If a solder short occurs, remove it with your hot iron. Use only rosin core solder of 63/37 or 60/40 alloy. Before soldering the SM-200K board should be taped to the workbench to keep it from moving when touched with the soldering iron. For a good soldering job, the areas being soldered must be heated sufficiently so that the solder flows freely. When soldering surface mount resistors and capacitors, the following procedure may be used:

1. Using tweezers, place the surface mount component on the PC board pads and secure in place with tape.
2. Apply a small amount of solder to the soldering iron tip. This allows the heat to leave the iron and flow onto the foil.

3. Place the iron in contact with the PC board foil. Apply a small amount of solder simultaneously to the foil and the component and allow them to melt the solder.
4. Remove the iron and allow the solder to cool. The solder should have flowed freely and not lump up around the component.
5. Remove the tape and solder the other side of the component.

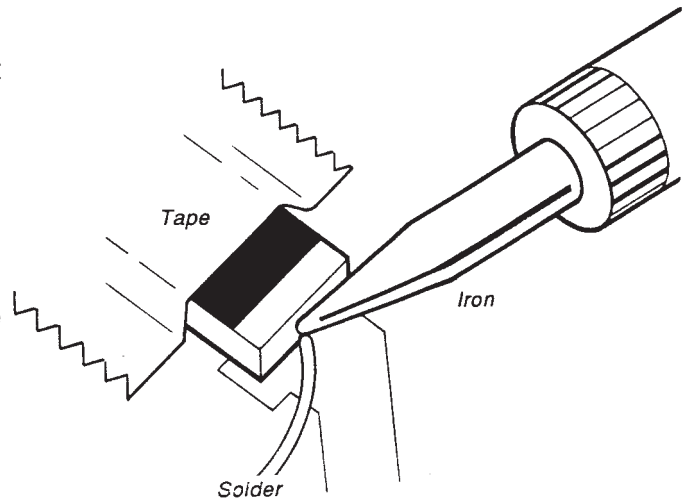

When soldering the transistors, diodes and integrated circuits, the following procedure may be used:

1. Place the component on the PC board pads and secure in place with tape.
2. Apply a small amount of solder to the soldering iron tip.
3. Place the soldering iron tip on top of the component lead to be soldered and apply solder simultaneously to the lead and the PC board foil.
4. Remove the iron and allow the solder to cool. The solder should have flowed freely and not lump up around the component.

After a component is completely soldered, each solder joint should be inspected with a magnifying glass. If the solder has not flowed smoothly, a bad solder joint is indicated. This occurs when the component and pad have not been heated sufficiently. To correct, reheat the connection and if necessary add a small amount of additional solder.

Another way to solder surface mount components is as follows:

1. Apply a small amount of solder to the soldering iron tip.
2. Using tweezers, hold the component on the PC board pads.
3. Apply the soldering iron simultaneously to the component and pad and allow the solder to flow around the component.
4. Remove the soldering iron and allow the connection to cool.

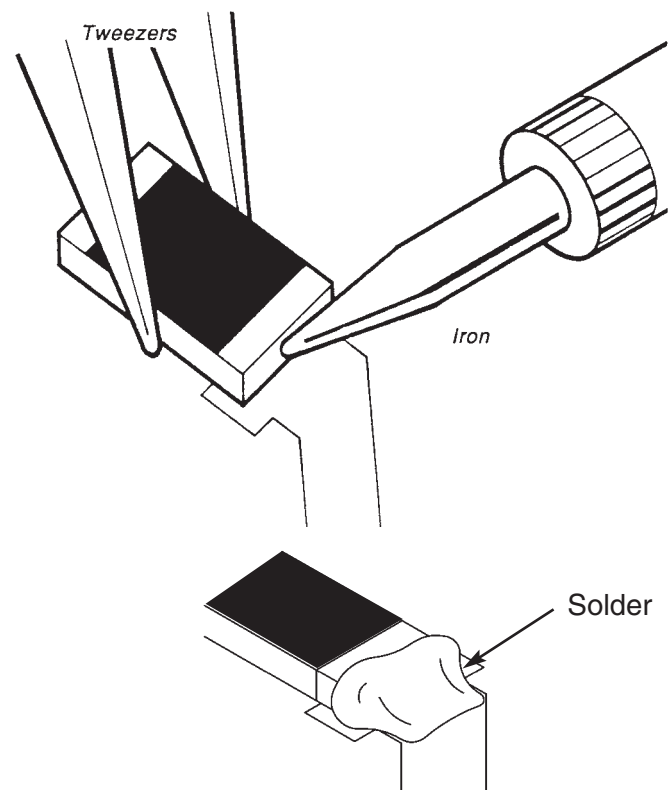

PRACTICE

If you are unfamiliar with soldering surface mount components, it would help to practice a bit before starting the assembly process. Six 0 ohm resistors, marked (000), are supplied with the SM-200K kit. Only two are used in the assembly process. The other four may be used for practice. Use the PC board area shown in Figure 5. If you have not already done so, read the soldering tips in the previous section. Try both of the methods described to see which you prefer.

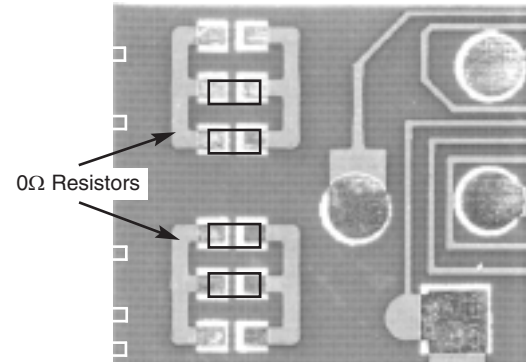
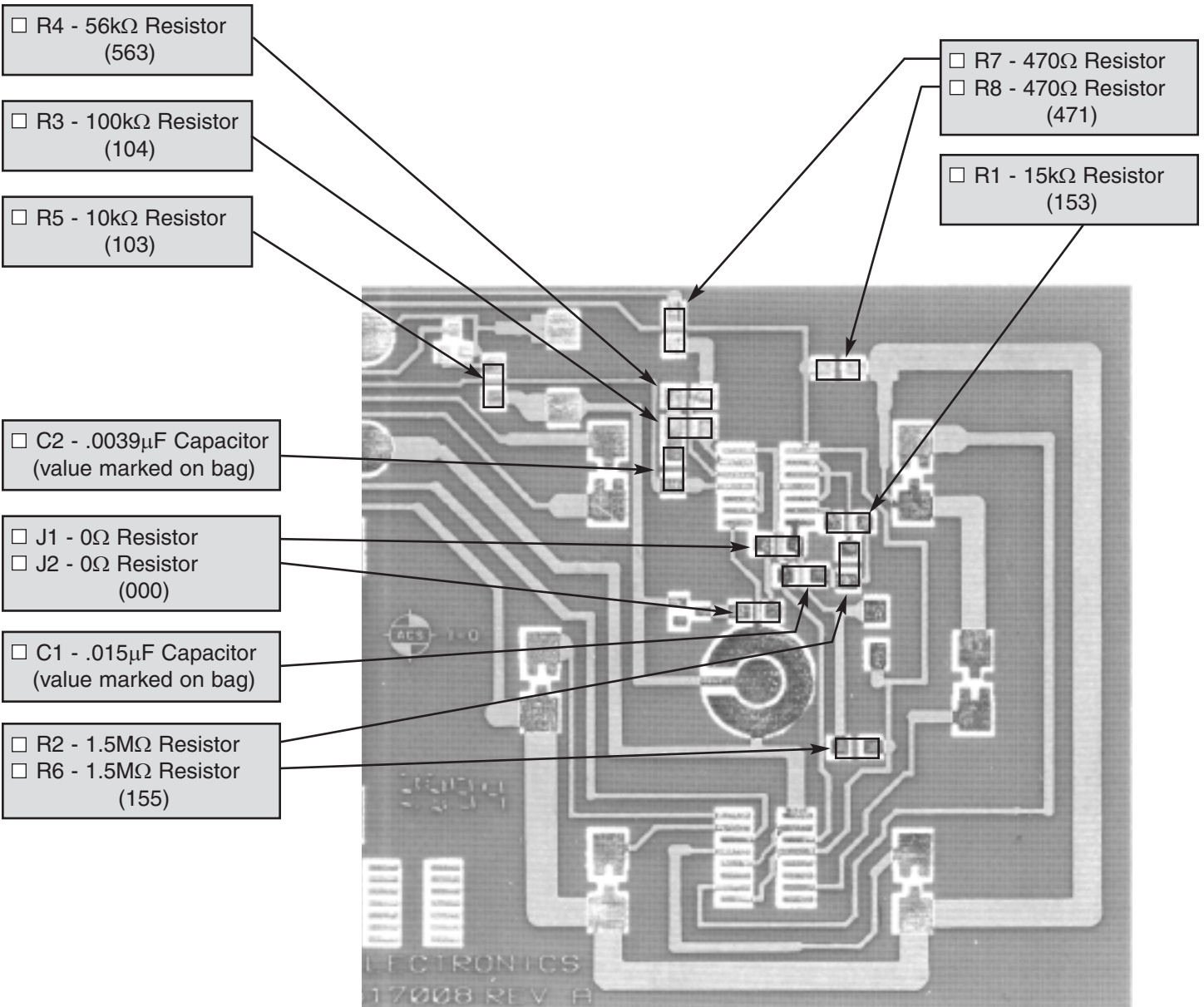

Figure 5

SOLDER RESISTORS AND CAPACITORS TO PC BOARD

Be sure to read the section on soldering tips. Then follow the step by step instructions below. As each step is completed, place a check mark in the box next to the instruction.



SOLDER CAPACITORS AND SEMICONDUCTORS TO PC BOARD

□ D1 - Diode (1N4148)
(RA6J), (A6),
(A2) or
(5H)

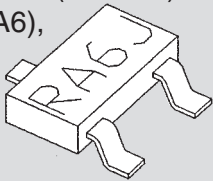

□ C3 - 100 μ F Lytic
(See Figure 8)

□ Q1 - Transistor (3904)
(R1A), (1A),
(N71),
(1AM), or
(KINC)

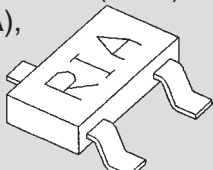

□ LED 1
□ LED 2
□ LED 3

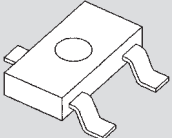

Figure 6
Mount IC with pin 1 as shown on the
PC board illustration.

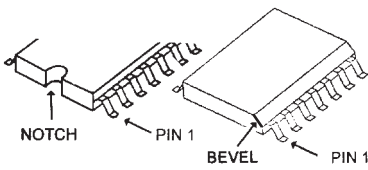

Figure 7
Mount IC with pin 1 as shown on the
PC board illustration.

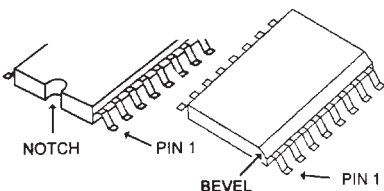

Figure 8
This capacitor is
polarized, be sure
that the (+) and (-)
sides are positioned
correctly.

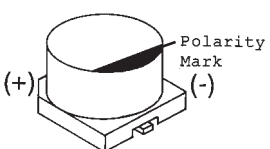
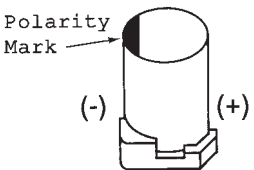
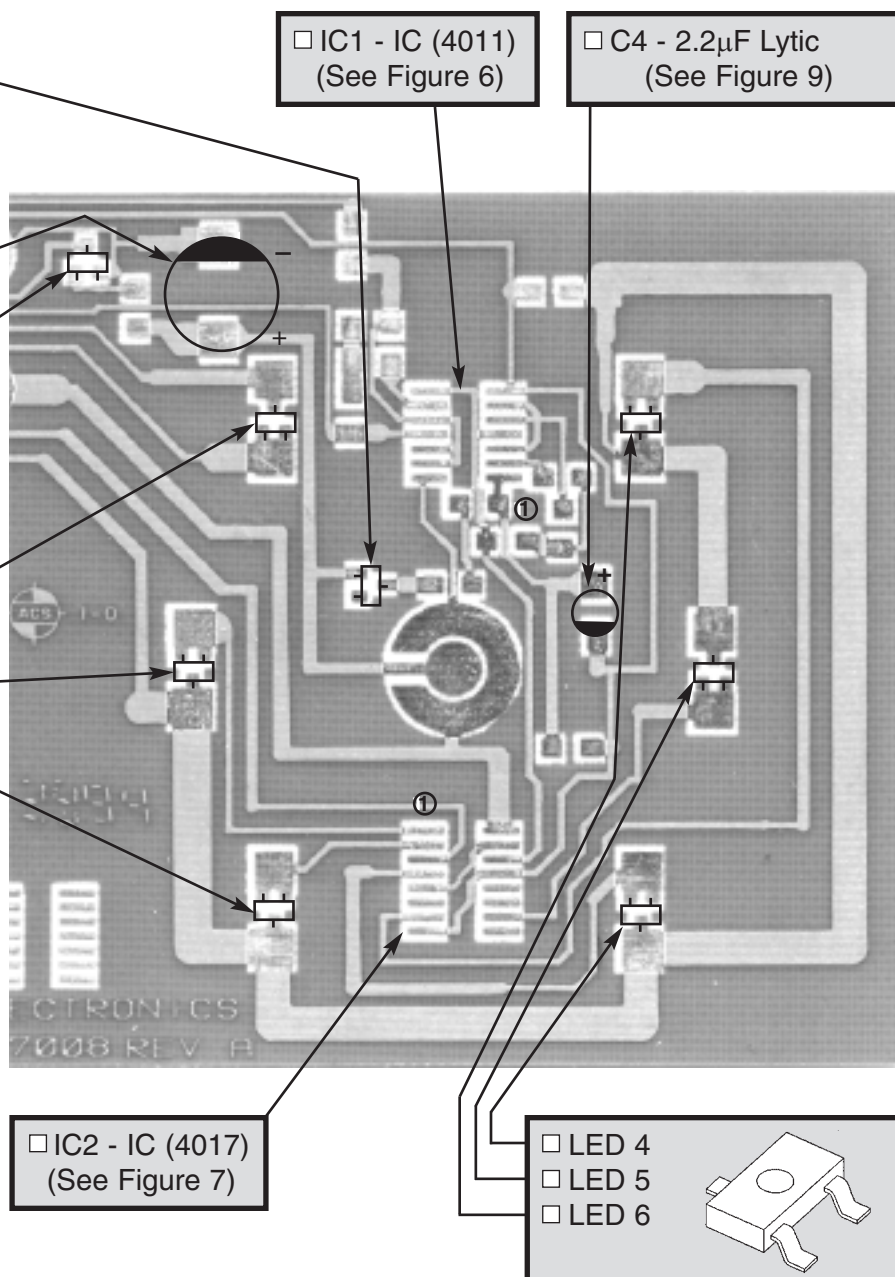

Figure 9
This capacitor is
polarized, be sure
that the (+) and (-)
sides are positioned
correctly.

ASSEMBLE LARGE COMPONENTS TO PC BOARD

□ Place the buzzer on the PC board with the white center facing outward and solder to the PC board at the points shown in Figure 10.

□ Strip 1/8 inch of insulation off both ends of the short red wire. Solder the wire to the buzzer and the PC board as shown in Figure 10. Be sure the wire is on the center portion of the buzzer and not on the outer rim.

□ Solder the red and black battery snap wires to the PC board as shown in Figure 10.

□ Place the dimple switch, domed upward, on the PC board as shown in Figure 11. Be sure none of the contact points touch the lead in foil to the center ring of the switch foil.

□ Peel one layer of the protective backing off the double sided scotch tape. Place the tape over the dimple switch as shown in Figure 11. Press the tape to the PC board and peel off the remaining protective backing.

□ Stick the 7/32 inch spacer onto the dimple switch as shown in Figure 12.

Connect the 9V battery and push the spacer. The buzzer should sound and the LEDs should flash as described in the Introduction. If this does not happen, refer to the Troubleshooting section. The unit should be working before completing the final assembly.

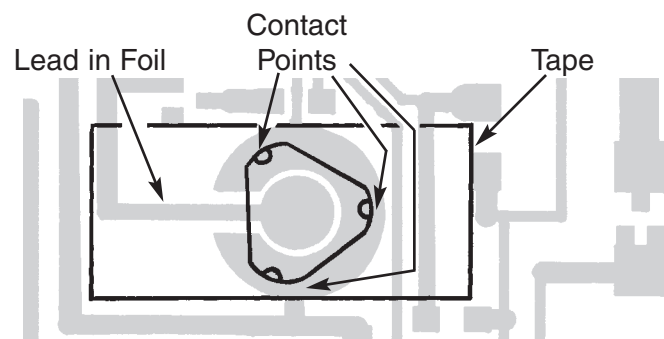
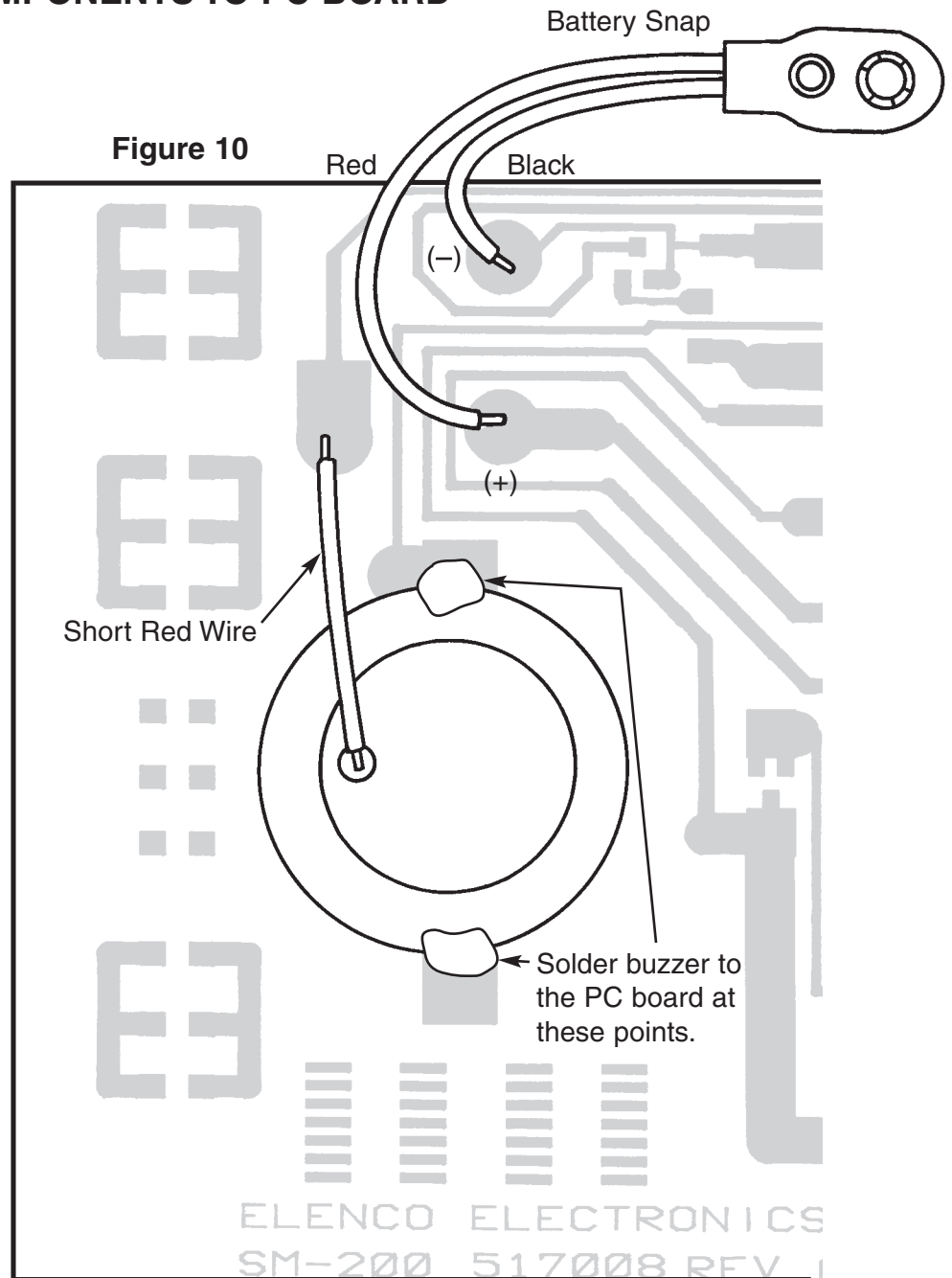

Figure 11

FINAL ASSEMBLY

- Use a scissor or single edge razor blade to cut the thick cushion tape into four 1/4 inch pieces. Peel off one of the protective layers and stick the tape to the corners of the PC board as shown in Figure 12.
- Peel the protective backing off the 3 X 4 1/2 inch red filter.
- Remove the remaining protective backing from the cushion tape. Align the word ASK on the red filter with the 7/32 inch spacer and stick the filter to the cushion tape as shown in Figure 12.

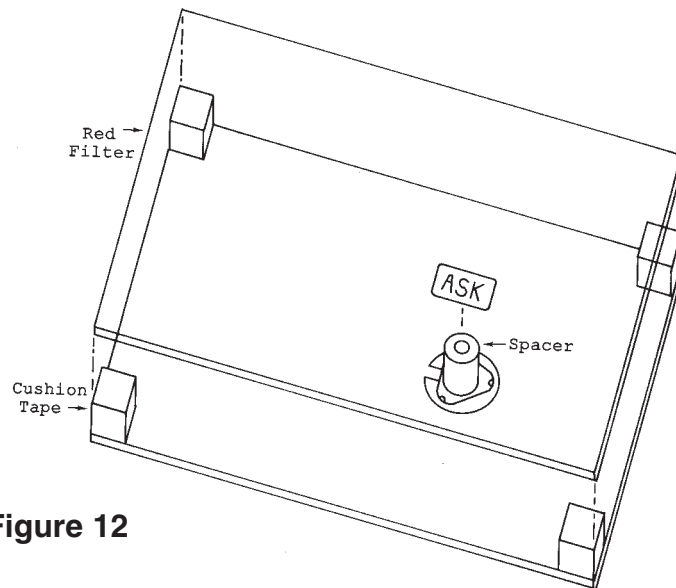

Figure 12

TROUBLESHOOTING

A) NO SOUND AND NO LEDs

- 1) Check that the battery snap is wired as shown in Figure 10.
- 2) Check that IC1 and IC2 are not installed backwards (see Figures 6 and 7). Be sure there are no solder bridges between the IC pins.
- 3) Check that the dimple switch is mounted with the dome upward.
- 4) Check the value and the soldering of R5.
- 5) Check Q1.

B) SOUND BUT NO LEDs

- 1) Check that IC2 is not mounted backwards (see Figure 7). Be sure there are no solder bridges between the IC pins.
- 2) Check the value and soldering of R8.
- 3) Check LED1 through LED6.

C) LEDs BUT NO SOUND

- 1) Check that the buzzer is soldered as in Figure 10. Check the solder connection between the jumper wire and the center part of the buzzer.
- 2) Check for soldering bridges between the pins of IC1.
- 3) Check the value and the soldering of R3, R4, and R7.

D) LEDs STOP AS SOON AS SWITCH IS RELEASED

- 1) Check that C3 is mounted as shown in Figure 8.
- 2) Check that C2 is mounted as shown in Figure 9.
- 3) Check the value and soldering of R6.
- 4) Check D1.

SM-200K QUIZ

- 1) When soldering surface mount resistors, apply the solder
 - A) To the component only.
 - B) Simultaneously to the foil and the component.
 - C) To the foil only.
 - D) First to the component and then to the soldering iron.
- 2) When driven by clock pulses, the outputs of the decade counter
 - A) All go high and remain high.
 - B) All go high and low simultaneously.
 - C) Go high one at a time in sequence.
 - D) Go low two at a time in sequence.
- 3) On a surface mount resistor
 - A) The last two digits refer to the resistance in ohms.
 - B) The first digit designates ohms, $k\Omega$, or $M\Omega$.
 - C) The middle digit designates ohms, $k\Omega$, or $M\Omega$.
 - D) The first two digits refer to the resistance in ohms.
- 4) The LEDs are driven by
 - A) An operational amplifier.
 - B) A decade counter.
 - C) A hex inverter with open collector outputs.
 - D) A monostable multivibrator.
- 5) The 4017 IC contains
 - A) A 5 stage divide by 10 counter.
 - B) A 10 stage divide by 5 counter.
 - C) Four-two input NAND gates.
 - D) Six inverters with open collector outputs.
- 6) The SM-200K uses
 - A) 10 oscillator circuits.
 - B) 6 oscillator circuits.
 - C) 2 oscillator circuits.
 - D) None of the above.
- 7) The 4011 IC contains
 - A) A 5 stage divide by 10 counter.
 - B) A 10 stage divide by 5 counter.
 - C) Four-two input NAND gates.
 - D) Six inverters with open collector outputs.
- 8) When a voltage is applied to the piezoelectric buzzer, it
 - A) Changes dimensions.
 - B) Heats up.
 - C) Cools down.
 - D) None of the above.
- 9) When the ASK button is pushed
 - A) Capacitor C4 charges to 9V.
 - B) Capacitor C3 charges to 9V.
 - C) The oscillators run.
 - D) All of the above.
- 10) After the oscillators stop, the remaining LED gradually goes out as
 - A) C3 loses its charge.
 - B) The LEDs become forward biased.
 - C) C2 loses its charge.
 - D) Q1 starts to conduct.

Answers: 1. B, 2. C, 3. D, 4. B, 5. A, 6. C, 7. C, 8. A, 9. D, 10. A

SCHEMATIC DIAGRAM

