

Ground Fault Circuit Interrupters

1060/1070 Series Multiple Outlet GFCIs

1075 Series Panel Mount GFCIs

XG2 Series In-Line GFCIs



Ground Fault Circuit Interrupters

Introduction

Ericson Manufacturing Company engineers and produces a comprehensive range of portable Ground Fault Circuit Interrupters that help you create the safer workplace you desire and help your company **comply with NEC and OSHA regulations**. Ericson's Ground Guardian™ & Piranha™ range of portable GFCIs are perfect for wet and conductive locations/ jobsites where standing water is present and for use on any electrically powered portable tool such as drills, saws, drain cleaners, and much more. Additionally, **Ericson offers more models in automatic and manual power-up configurations than any other manufacturer**. In the following pages you will find:

- A wide range of portable GFCI products
- Ground Guardian™, In-Line GFCI Cordsets, Panel Mount and Multi-Outlet portable GFCIs
- A wide variety of Specialty Devices such as GFCIs Factory wired with watertight plugs & connectors or Ericson's portable outlet boxes
- Automatic & Manual power-up models
- Easy to use charts and drawings simplify the selection/specification process making it quick and user friendly
- Technical reference information including dimensional drawings, how GFCI's work & code requirements

In-Line GFCI Cordsets (Piranha XG2 Series)

- UL & cUL Listed
- NEMA Type 4, 4X, 6 & 6P enclosure excels in demanding outdoor & in-plant environments
- Switch rated up to 1.5 HP
- 15Amp & 20 Amp/120V models
- Available as automatic and manual power-up configurations
- Available with a variety of different cord lengths

Panel-Mount GFCIs (1075 Series)

- UL & cUL Listed
- 20Amp/120Volt models
- Available as automatic and manual power-up configurations

Multi-Outlet GFCIs (1060 & 1070 Series)

- UL & cUL Listed
- 15 & 20Amp/120Volt models
- Available as automatic and manual power-up configurations

NEW!

Custom Built Devices

As always, you can turn to Ericson Manufacturing Company to engineer a solution for your portable GFCI application if you do not find a standard catalog item to fit your need. Contact the factory or your local sales representative to find out more.

Ground Fault Circuit Interrupters

How a Ground Fault Circuit Interrupter Works

How a Ground Fault Circuit Interrupter works

As explained in OSHA Regulation 1926.404, an option for safe compliance in temporary power set-ups is the use of a Ground Fault Circuit Interrupter (GFCI). The GFCI is a fast-acting circuit breaker that senses small imbalances in the circuit caused by current leakage to ground and, in a fraction of a second, shuts off the electricity. A GFCI continually monitors the amount of current returning from the device along the normal electrical path. Whenever the amount "returning" differs from the amount "going" by more than $5 \text{ mA} \pm 1 \text{ mA}$, the GFCI interrupts the current - preventing electrocution.

Beware of "open neutrals" and "reverse phasing"

Normally, GFCI receptacles (like those found in your bathroom) can sense ground-fault circuits. However, if the line-side neutral conductor is opened or lifted at a panel, the circuitry in the GFCI receptacles will not have the necessary 125V power from which to operate. That means that GFCI is no longer capable of sensing and disengaging. This is called an "open neutral." Anyone using the receptacles protected by the disabled GFCI will not have GFCI protection. And if a faulted tool is connected to the now-unprotected receptacle, the user will be exposed to a shock or electrocution hazard.

This is why jobsite GFCIs must provide open neutral protection.

The portable type GFCI provides open neutral protection to the user by disconnecting both output wires whenever either of the input wires are broken or disconnected. This protection is required for all portable GFCI units by UL Standard 943. GFCI's intended for fixed installation, such as receptacle GFCI's, are not required to provide this protection.

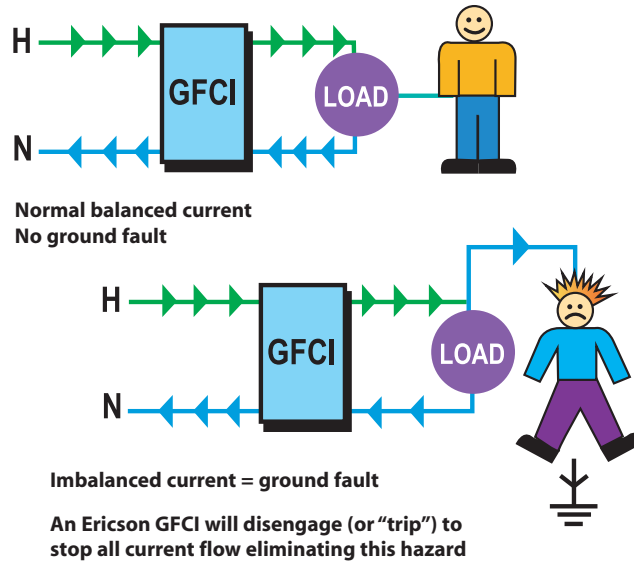

Temporary wiring installations are more likely to be improper than fixed installations. Because of this, portable GFCIs are required by UL Standard 943 to work properly when the supply side wires are reversed, or reverse-phased.

SAFE CURRENT VALUES

Milliamperes	Effect on Average Human
1 or less	Causes no sensation - not felt, is at threshold of perception.
1 to 8	Sensation of shock. Not painful. Individual can let go at will, as muscular control is not lost. (5mA is accepted as maximum harmless current intensity.)

UNSAFE CURRENT VALUES

Milliamperes	Effect on Average Human
8 to 15	Painful shock. Individual can let go at will, as muscular control is not lost.
16 to 20	Painful shock. Muscular control of adjacent muscles lost. Cannot let go.
21 to 99	Painful. Severe muscular contractions. Breathing is difficult.
100 to 200	Ventricular fibrillation. (A heart condition that may result) Disrupts or changes rhythm of the heart.
200 & over	Severe burns. Severe muscular contractions - so severe that chest muscles clamp heart and stop it during duration of shock. (This prevents ventricular fibrillation.)

Flexible Cords = Portable Danger

With the ever increasing presence of portable tools at jobsites, the use of flexible cords is a necessity. Flexible, exposed cords are more vulnerable to damage than fixed wiring. Hazards are often created when flexible cords, cord connectors, receptacles, cord-connected equipment or plug-connected equipment are improperly used or maintained.

Also, on-site routine objects, like door or window edges, staples or fasteners or abrasive materials can damage cords. Another frequent hazard on a construction site, is a cord assembly, with improperly connected terminals.

Moisture is a problem, too. When a cord connector is wet at any point, potentially fatal leakage can pass through an individual coming in contact at the point of leakage - electrocution can result.

That's why the Occupational Safety and Health Administration (OSHA) and the National Fire Protection Association have created ground fault protection standards for added electrical safety on the job.

Ground Fault Circuit Interrupters

XG2 Series In-Line Cordsets 120V/15A & 20Amp



NEW!

Features

- UL & cUL Listed to UL943-2003
- This unit combines a rugged cordset with the personal protection of a GFCI
- Compact & portable, this unit is easy to use, store and transport
- Works on two or three wire circuits
- Meets NEC & OSHA construction site requirements
- Fast response trip time; less than .025 seconds
- Molded polycarbonate enclosure is corrosion and impact resistant, and stands up to the toughest jobsite conditions
- Automatic and Manual power-up models available
- Engineered strain relief protect cord from excessive bending and pulling
- Test and Reset Buttons are clearly marked for easy identification and each is protected from accidental activation
- Factory Wired with SJT cable in standard lengths up to 50'
- Custom Configurations available for your in-plant or OEM application - Simply complete the appropriate custom product request form and fax it to the factory for a quotation

Listings

- UL & cUL listed

Specifications:

Material

- Enclosure: UV resistant Polycarbonate
- Strain Relief: PBT/TPE

Electrical

- Power-up type: Automatic & Manual
- Trip level: 4-6mA
- Trip time: less than 25ms (0.025 seconds)
- Leakage current in 93% relative humidity: Zero
- Operating voltage: 120VAC nominal rating (85% to 110% of rated voltage: 102V-132V)
- Grounded neutral detection: 2 ohms or less
- Frequency: 50/60Hz
- Overload current: (15A models) 90 amps 50% power factor, 1 second
- Overload current: (20A models) 120 amps 50% power factor, 1 second
- Radio frequency noise susceptibility: Operates normally with 0.5 VRMS, 10-450Mhz, injected on power lines
- Voltage surge withstand: 6KV impulse, 0.5 microsecond rise time, 100Khz ringing frequency with 40% decay per cycle
- Dielectric voltage withstand:
 - 1500 VRMS between line & load (across contacts)
 - 2500 VRMS between current carrying conductors and ground conductor
 - 4000 VRMS between current carrying conductors and enclosure
 - 4000 VRMS between ground conductor and enclosure

Mechanical

- Color: Black Enclosure
- Power Status Indicator: Lighted NEON
- Contact Size: 0.200" diameter
- Contact Latching: Electro-mechanical
- Cord Types: SJT, SJO, ST, SO

Environmental

- NEMA Type 4, 4X, 6 & 6P enclosure
- Operating Temperature Range: -35°C to +66°C
- Flammability: UL94 5V



Ground Fault Circuit Interrupters

XG2 Series In-Line Cordsets 120V/15A & 20Amp

Compact & portable, this unit is easy to use, store & transport.

Automatic & manual power-up models are available.

Available with factory-wired & molded-on devices.

High intensity neon lamp glows bright when power is on for easy identification of power status.

Engineered strain relief protects cord from excessive bending & pulling.

NEMA TYPE 4, 4X, 6 & 6P
polycarbonate enclosure is corrosion, impact, UV and water tight.

Test & Reset buttons clearly marked for easy identification & recessed to prevent accidental activation.

A wide variety of outlets are available; from molded-on single connector & Tri-Tap™ to Perma-Grip™ devices & Ericson outlet boxes.

Works on two-wire or three-wire circuits.

NEMA TYPE 4, 4X, 6 & 6P

- Excels in demanding outdoor & in-plant environments
- Resists hose directed water, the entry of water during prolonged submersion at a limited depth & damage from external ice formation

- Available in 15A & 20A models.
- Up to 1.5 horse-power switch rating

Oversized test & reset buttons are easier to operate and provide enhanced tactile feel & audible feedback.

Model XG2-12-2BW shown



Meets NEC & OSHA construction site requirements

Available with a variety of cord lengths & types.

Custom configurations are available for your jobsite or OEM applications. Contact your nearest representative or the factory today!



NEMA TYPE 4X & 6P Enclosure

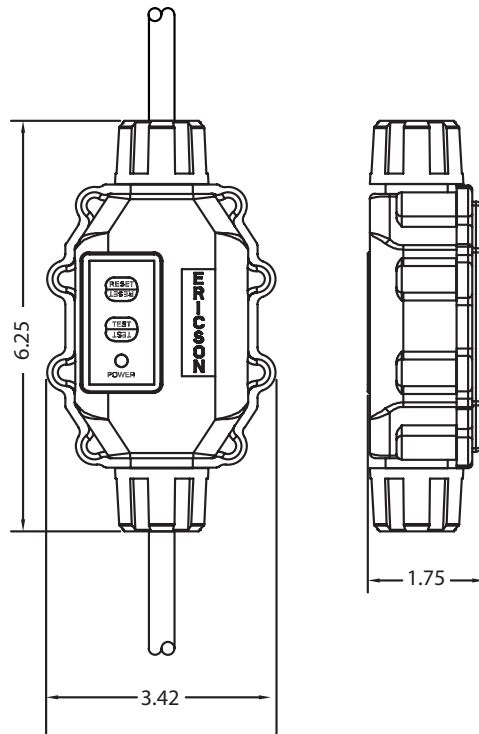

Ground Fault Circuit Interrupters

XG2 Series In-Line Cordsets 120V/15A & 20Amp

Catalog Number	Power-Up Type	Cord		Plug/Outlet(s)	Volts	Amps	Watts
		Length	Type				
With Molded-On Plug and Connector							
XG2-14-2S	Auto	2'	SJT	5-15	125	15	1875
XG2-14-6S	Auto	6'	SJT	5-15	125	15	1875
XG2-14-25S	Auto	25'	SJT	5-15	125	15	1875
XG2-14-2S-MR	Manual	2'	SJT	5-15	125	15	1875
XG2-14-6S-MR	Manual	6'	SJT	5-15	125	15	1875
XG2-14-25S-MR	Manual	25'	SJT	5-15	125	15	1875
With Molded-On Plug and Tri-Tap™ Connector							
XG2-12-2TT	Auto	2'	SJT	5-15	125	15	1875
XG2-12-6TT	Auto	6'	SJT	5-15	125	15	1875
XG2-12-25TT	Auto	25'	SJT	5-15	125	15	1875
XG2-12-50TT	Auto	50'	SJT	5-15	125	15	1875
XG2-12-2TT-MR	Manual	2'	SJT	5-15	125	15	1875
XG2-12-6TT-MR	Manual	6'	SJT	5-15	125	15	1875
XG2-12-25TT-MR	Manual	25'	SJT	5-15	125	15	1875
XG2-12-50TT-MR	Manual	50'	SJT	5-15	125	15	1875
With Factory-Wired Perma-Grip™ Plug and Connector							
XG2-14-2G	Auto	2'	SJT	5-15	125	15	1875
XG2-14-6G	Auto	6'	SJT	5-15	125	15	1875
XG2-14-25G	Auto	25'	SJT	5-15	125	15	1875
XG2-14-2G-MR	Manual	2'	SJT	5-15	125	15	1875
XG2-14-6G-MR	Manual	6'	SJT	5-15	125	15	1875
XG2-14-25G-MR	Manual	25'	SJT	5-15	125	15	1875
XG2-12-2G	Auto	2'	SJT	5-20	125	20	2500
XG2-12-6G	Auto	6'	SJT	5-20	125	20	2500
XG2-12-25G	Auto	25'	SJT	5-20	125	20	2500
XG2-12-2G-MR	Manual	2'	SJT	5-20	125	20	2500
XG2-12-6G-MR	Manual	6'	SJT	5-20	125	20	2500
XG2-12-25G-MR	Manual	25'	SJT	5-20	125	20	2500
XG2-12-2G-LKG	Auto	2'	SJT	L5-20	125	20	2500
XG2-12-25G-LKG	Auto	25'	SJT	L5-20	125	20	2500
XG2-12-2G-LKG-MR	Manual	2'	SJT	L5-20	125	20	2500
XG2-12-25G-LKG-MR	Manual	25'	SJT	L5-20	125	20	2500
XG2-12-2G-15	Auto	2'	SJT	5-15	125	15	1875
XG2-12-25G-15	Auto	25'	SJT	5-15	125	15	1875
XG2-12-2G-15-MR	Manual	2'	SJT	5-15	125	15	1875
XG2-12-25G-15-MR	Manual	25'	SJT	5-15	125	15	1875
With Factory-Wired Perma-Tite® 2 Plug and Connector							
XG2-14-2W	Auto	2'	SJT	5-15	125	15	1875
XG2-14-6W	Auto	6'	SJT	5-15	125	15	1875
XG2-14-25W	Auto	25'	SJT	5-15	125	15	1875
XG2-14-2W-MR	Manual	2'	SJT	5-15	125	15	1875

Ground Fault Circuit Interrupters

XG2 Series In-Line Cordsets 120V/15A & 20Amp

Catalog Number UL & cUL Listed	Power-Up Type	Cord		Plug/ Outlet(s)	Volts	Amps	Watts
		Length	Type				
With Factory-Wired Perma-Tite® 2 Plug and Connector (continued)							
XG2-14-6W-MR	Manual	6'	SJT	5-15	125	15	1875
XG2-14-25W-MR	Manual	25'	SJT	5-15	125	15	1875
XG2-12-2W	Auto	2'	SJT	5-20	125	20	2500
XG2-12-6W	Auto	6'	SJT	5-20	125	20	2500
XG2-12-25W	Auto	25'	SJT	5-20	125	20	2500
XG2-12-2W-MR	Manual	2'	SJT	5-20	125	20	2500
XG2-12-6W-MR	Manual	6'	SJT	5-20	125	20	2500
XG2-12-25W-MR	Manual	25'	SJT	5-20	125	20	2500
XG2-12-2W-LKG	Auto	2'	SJT	L5-20	125	20	2500
XG2-12-25W-LKG	Auto	25'	SJT	L5-20	125	20	2500
XG2-12-2W-LKG-MR	Manual	2'	SJT	L5-20	125	20	2500
XG2-12-25W-LKG-MR	Manual	25'	SJT	L5-20	125	20	2500
XG2-12-2W-15	Auto	2'	SJT	5-15	125	15	1875
XG2-12-25W-15	Auto	25'	SJT	5-15	125	15	1875
XG2-12-2W-15-MR	Manual	2'	SJT	5-15	125	15	1875
XG2-12-25W-15-MR	Manual	25'	SJT	5-15	125	15	1875
With Factory-Wired 6000 Box, Two Duplex Receptacles and Perma-Grip™ Plug							
XG2-12-2B	Auto	2'	SJT	5-20	125	20	2500
XG2-12-25B	Auto	25'	SJT	5-20	125	20	2500
XG2-12-50B	Auto	50'	SJT	5-20	125	20	2500
XG2-12-50B	Auto	50'	SJT	5-20	125	20	2500
XG2-12-2B-MR	Manual	2'	SJT	5-20	125	20	2500
XG2-12-25B-MR	Manual	25'	SJT	5-20	125	20	2500
XG2-12-50B-MR	Manual	50'	SJT	5-20	125	20	2500
XG2-12-2B-15	Auto	2'	SJT	5-15	125	15	1875
XG2-12-25B-15	Auto	25'	SJT	5-15	125	15	1875
XG2-12-50B-15	Auto	50'	SJT	5-15	125	15	1875
XG2-12-2B-15-MR	Manual	2'	SJT	5-15	125	15	1875
XG2-12-25B-15-MR	Manual	25'	SJT	5-15	125	15	1875
XG2-12-50B-15-MR	Manual	50'	SJT	5-15	125	15	1875
With Factory-Wired 6100 Box, Two Duplex Receptacles and Perma-Tite® 2 Plug							
XG2-12-2BW	Auto	2'	SJT	5-20	125	20	2500
XG2-12-25BW	Auto	25'	SJT	5-20	125	20	2500
XG2-12-50BW	Auto	50'	SJT	5-20	125	20	2500
XG2-12-2BW-MR	Manual	2'	SJT	5-20	125	20	2500
XG2-12-25BW-MR	Manual	25'	SJT	5-20	125	20	2500
XG2-12-50BW-MR	Manual	50'	SJT	5-20	125	20	2500
XG2-12-2BW-15	Auto	2'	SJT	5-15	125	15	1875
XG2-12-25BW-15	Auto	25'	SJT	5-15	125	15	1875
XG2-12-50BW-15	Auto	50'	SJT	5-15	125	15	1875
XG2-12-2BW-15-MR	Manual	2'	SJT	5-15	125	15	1875
XG2-12-25BW-15-MR	Manual	25'	SJT	5-15	125	15	1875
XG2-12-50BW-15-MR	Manual	50'	SJT	5-15	125	15	1875

XG2-14-2S

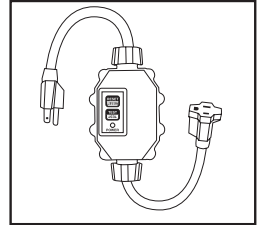

XG2-12-2TT

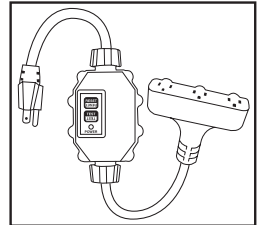

XG2-14-2G

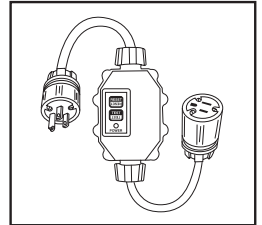

XG2-12-2W

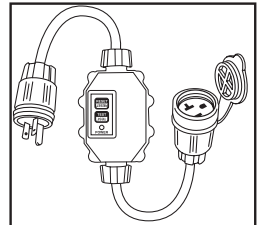

XG2-12-2B

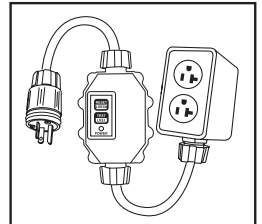

XG2-12-2BW

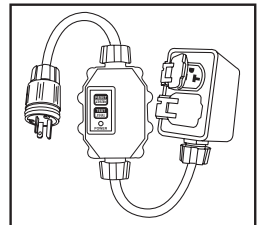

Ground Fault Circuit Interrupters

XG2 Series In-Line Cordsets 120V/15A & 20Amp

XG2 SERIES IN-LINE GFCI POWER CORDS CUSTOM PRODUCT REQUEST FORM

TYPICAL CONFIGURATION

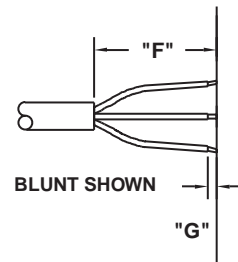
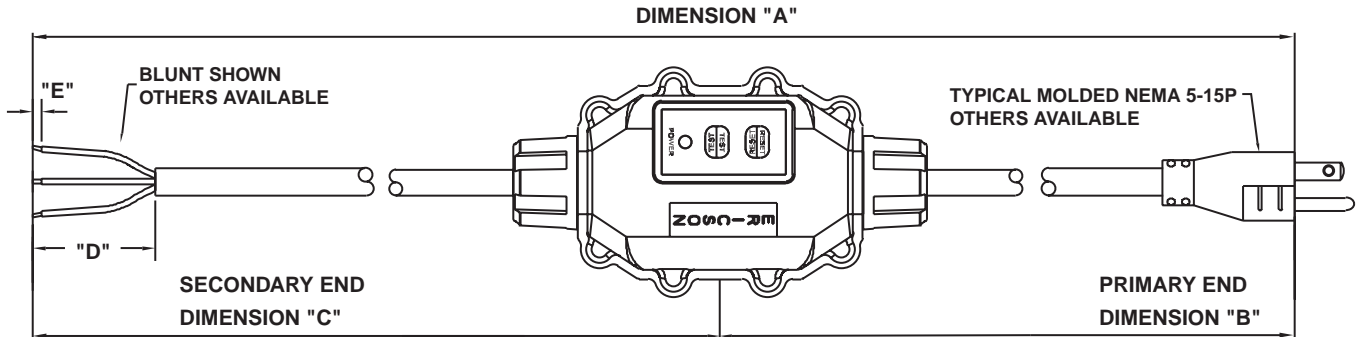

CHECK BOXES THAT APPLY.

INPUT REQUIREMENTS		
VOLTAGE	CURRENT	FREQUENCY
120 VAC	13 AMPS <input type="checkbox"/>	50/60 Hz
120 VAC	15 AMPS <input type="checkbox"/>	50/60 Hz
120 VAC	20 AMPS <input type="checkbox"/>	50/60 Hz

RESET TYPE	
MANUAL	<input type="checkbox"/>
AUTO	<input type="checkbox"/>

TEMP RATING	
MIN	-35C
MAX	66C

CASE COLOR	
TOP	BOTTOM
BLACK	BLACK

CABLE REQUIREMENTS		
JACKET TYPE	GAGE	COLOR
STW <input type="checkbox"/>	AWG 16 <input type="checkbox"/>	BLACK <input type="checkbox"/>
SJTW <input type="checkbox"/>	AWG 14 <input type="checkbox"/>	YELLOW <input type="checkbox"/>
	AWG 12 <input type="checkbox"/>	OTHER <input type="checkbox"/>
		(SPECIFY)

CABLE NOTES:

- 1) PRIMARY CABLE AND SECONDARY CABLE TYPES SHOULD BE THE SAME.
- 2) AWG 14 MINIMUM FOR 15 AMP SERVICE
- 3) AWG 12 MINIMUM FOR 20 AMP SERVICE
- 4) AWG 16 TYPE SJ NOT AVAILABLE.

GENERAL NOTES:

- 1) UNITS WITH BOTH CORD CAPS ARE UL/CUL LISTED.
- 2) UNITS WITH ONE OR BOTH ENDS BLUNT ARE UL RECOGNIZED.
- 3) OTHER NON-UL UNITS AVAILABLE BY CUSTOMER REQUEST.
- 4) DIM "B" SHOULD BE 1 FOOT OR LESS.
- 5) CONSULT FACTORY FOR CUSTOM LOGOS.

DIMENSIONS						
"A"	"B"	"C"	"D"	"E"	"F"	"G"

PRIMARY TERMINATION	
BLUNT & STRIP	<input type="checkbox"/>
BLUNT, STRIP & CRIMP	<input type="checkbox"/>
MOLDED-ON PLUG	<input type="checkbox"/>
MECHANICALLY ATTACHED PLUG	<input type="checkbox"/>

SECONDARY TERMINATION	
BLUNT & STRIP	<input type="checkbox"/>
BLUNT, STRIP & CRIMP	<input type="checkbox"/>
MOLDED-ON PLUG	<input type="checkbox"/>
MECHANICALLY ATTACHED PLUG	<input type="checkbox"/>

TERMINATION NOTES:

- 1) IF CRIMPS ARE SELECTED PLEASE SPECIFY INSULATED/NON-INSULATED AND RING/FORK/QUICK DISC, AND AND STUD SIZE.
- 2) IF MOLDED CORD CAPS ARE SELECTED, NOT ALL CABLE TYPES ARE AVAILABLE.

Ground Fault Circuit Interrupters

1060-1070 Series Multiple Outlet GFCI 120V/20 Amp



Series 1060*

*Actual product appearance may vary



Series 1070



Features

- UL Listed and CSA Certified for wet locations
- Polycarbonate, Impact resistant enclosure retains its properties under the most extreme environmental conditions
- Spring-loaded flip lids protect outlets from jobsite contaminants when not in use
- Unit comes standard with extra hard usage #12/3 SEO cable
- Meets OSHA construction site requirements
- Fast response trip time; less than .025 seconds
- Manual & automatic power-up
- Test and Reset Buttons are clearly marked for easy identification and each is protected from accidental activation
- High intensity NEON indicator lamp glows bright when power is on for easy identification of power status
- Optional Intel-A-Lite GCM Ground Continuity Monitor available - Continuously monitors integrity of ground
- Field serviceable

Specifications:

Material

- Enclosure: UV resistant Polycarbonate
- Warning label: UL approved polyester
- Product label: UL approved polyester

Electrical

- Power-up type: Manual & Automatic
- Trip level: 4-6mA
- Trip time: less than 25ms (0.025 seconds)
- Leakage current in 93% relative humidity: Zero
- Operating voltage: 120VAC nominal rating (85% to 110% of rated voltage: 102V-132V)
- Low voltage let go: 40% of rated voltage
- Grounded neutral detection: 2 ohms or less
- Frequency: 50/60Hz
- Overload current: 120 Amps, 50% inductive power factor, 1 second
- Radio frequency noise susceptibility: Operates normally with 0.5 VRMS, 10-450Mhz, injected on power lines
- Voltage surge withstand: 6KV impulse, 0.5 microsecond rise time, 100Khz ringing frequency with 40% decay per cycle
- Dielectric voltage withstand:
 - 1500 VRMS between line & load (across contacts)
 - 2500 VRMS between current carrying conductors and ground conductor
 - 4000 VRMS between current carrying conductors and enclosure
 - 4000 VRMS between ground conductor and enclosure

Mechanical

- Color: Yellow Enclosure with Blue bushing nut
- Power Status Indicator: Lighted NEON
- Contact Latching: Electro-mechanical

Environmental

- Operating Temperature Range: -35°C to +66°C
- Flammability: UL94HB



Made in the USA

160

ERICSON
safety electrical specialties

Call Toll-Free 1-800-ERICSON (374-2766)

Ground Fault Circuit Interrupters

1060-1070 Series Multiple Outlet GFCI 120V/15A & 20Amp

Selection Guide

Catalog Number	Type	Outlets	Primary Cord		Plug	Volts	Amps	Watts
			Length	Type				
1060	Manual	(4) NEMA 5-15 15A, 120Volt Straight Blade	6'	#12/3 SEO	5-15	120	15	1800
1060-A	Auto							
1061	Manual	(4) NEMA L5-15 15A, 120Volt Locking	6'	#12/3 SEO	L5-15	120	15	1800
1061-A	Auto							
1062	Manual	(4) NEMA 5-20 20A, 120Volt Straight Blade	6'	#12/3 SEO	5-20	120	20	2400
1062-A	Auto							
1070	Manual	(3) NEMA 5-15 15A, 120Volt Straight Blade	6'	#12/3 SEO	5-15	120	15	1800
1070-A	Auto							
1071	Manual	(3) NEMA L5-15 15A, 120Volt Locking	6'	#12/3 SEO	L5-15	120	15	1800
1071-A	Auto							
1072	Manual	(3) NEMA 5-20 20A, 120Volt Straight Blade	6'	#12/3 SEO	5-20	120	20	2400
1072-A	Auto							
1073	Manual	(3) NEMA L5-20 20A, 120Volt Locking	6'	#12/3 SEO	L5-20	120	20	2400
1073-A	Auto							
1074	Manual	(1) NEMA 5-20 20A, 120Volt Straight Blade & (2) NEMA L5-20 20A, 120Volt Locking	6'	#12/3 SEO	5-20	120	20	2400
1074-A	Auto							

Intel-A-Lite Option - Add suffix "M" to catalog number. 1060 becomes 1060M

Consult factory for custom configurations



Series 1060



Series 1070

Ground Fault Circuit Interrupters

1060-1070 Series Multiple Outlet GFCI 120V/15A & 20Amp

1060 Series

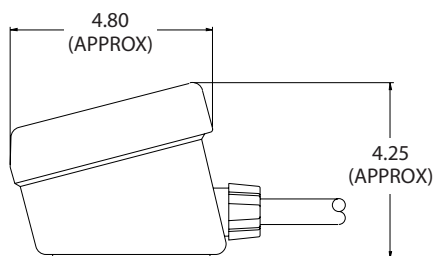
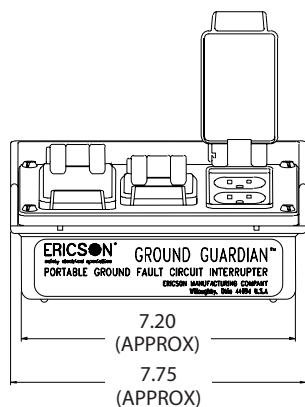
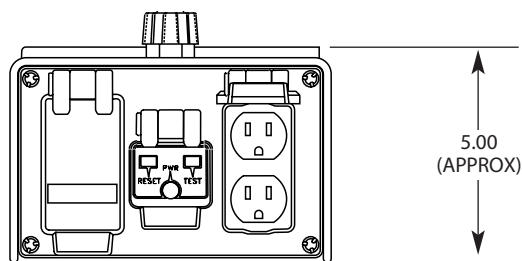

1070 Series

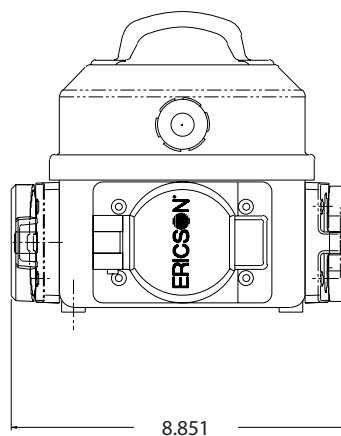
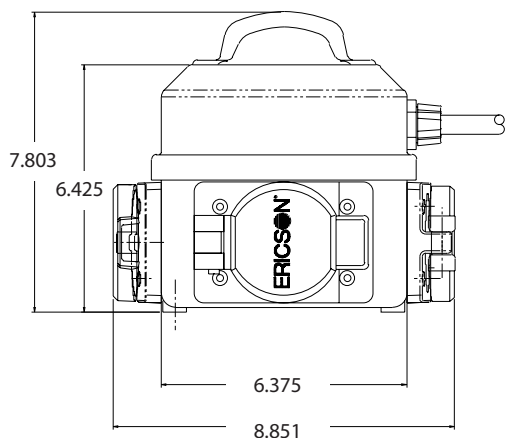
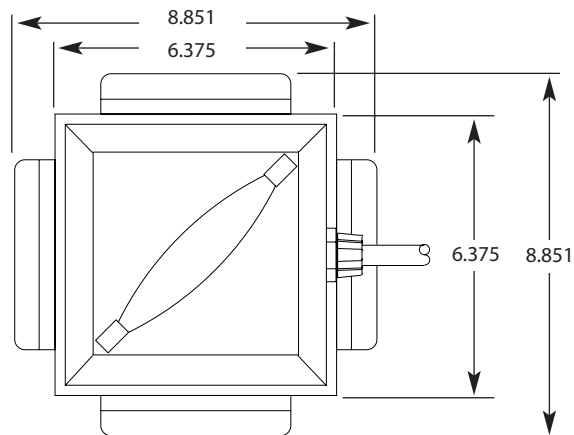

Ground Fault Circuit Interrupters

Model 1075 - Panel Mount GFCI 120V/15A,20A

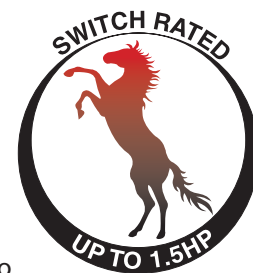

Specifications:

Material

- Enclosure: UV rated Polycarbonate

Electrical

- Power-up type: Manual or automated
- Trip level: 4-6mA
- Trip time: less than 25ms (0.025 seconds)
- Leakage current in 93% relative humidity: Zero
- Operating voltage: 120VAC nominal rating (85% to 110% of rated voltage: 102V-132V)
- Low voltage let go: 40% rated voltage
- Grounded neutral detection: 2 ohms or less
- Frequency: 60Hz only
- Overload current: 120Amps, inductive 50% Power factor, 1 second
- Radio frequency noise susceptibility: Operates normally with 0.5 VRMS, 10-450Mhz, injected on power lines
- Voltage surge withstand: 6KV impulse, 0.5 microsecond rise time, 100Khz ringing frequency with 40% decay per cycle
- Dielectric voltage withstand:
 - 1500 VRMS between line & load (across contacts)
 - 2500 VRMS between current carrying conductors and ground conductor
 - 4000 VRMS between current carrying conductors and enclosure

Features

- UL & cUL listed to UL943 - 2003
- Quick and easy field installation into temporary panels and workboxes
- Compact & portable, this unit is easy to use, store and transport
- Works on two or three wire circuits
- Meets OSHA construction site requirements
- Fast response trip time; less than .025 seconds
- Molded polycarbonate enclosure is corrosion and impact resistant, and stands up to the toughest jobsite conditions
- Manual & automatic power-up models available
- Test and Reset Buttons are clearly marked for easy identification and each is protected from accidental activation
- High intensity NEON indicator lamp glows bright when power is on for easy identification of power status

Safety Note: Although receptacle GFCIs appear to provide full-protection, they do not protect against open-neutral hazards! When the line-side neutral is open (which is not an unusual occurrence in temporary wiring installations) receptacle GFCI contacts are mechanically closed and the "hot" wire is still conducting electricity through the load side, which means you risk serious injury. Ericson's panel mount GFCIs DO protect against open neutral hazards, which is why they - and ALL Ericson GFCIs - meet UL, NEC and OSHA requirements.

Mechanical

- Color: Black Enclosure
- Power Status Indicator: Lighted NEON
- Contact Size: 0.200" dia.
- Contact Latching: Electro-mechanical

Environmental

- Operating Temperature Range: -35 °C to +66 °C
- UL94 5V flammability

Listings

- UL & cUL listed

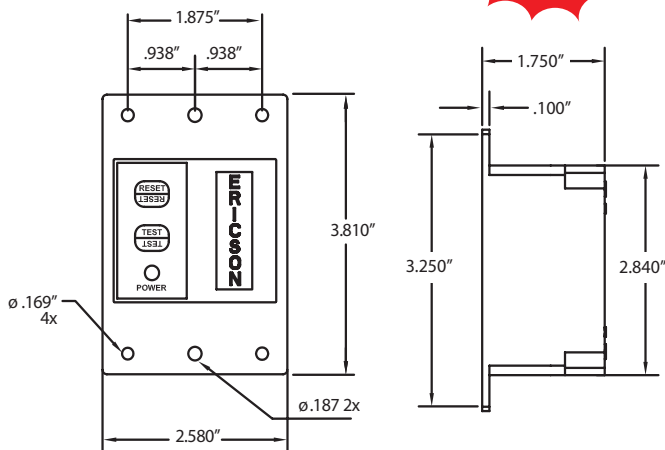

Selection Guide

Catalog Number	Type	Description	Volts	Amps	Watts
1075-MR	Manual	Panel mount GFCI	120V	20A	2400
1075-AR	Auto	Panel mount GFCI	120V	20A	2400



Ground Fault Circuit Interrupters

Oscar™ Series Temporary Power Distribution Centers

Ericson Manufacturing Company now offers a wide variety of temporary power distribution centers. These products, represented by Oscar™ the Octopus, allow the user to centralize and distribute temporary power safely. The product line consists of standard configurations, which can be customized to suit your needs. ETL listed to the new UL 1640 Standard for Safety, these units feature exclusive, Patent-Pending Technology not offered in competitive units. These safeguards provide protection for you *and* your equipment.

Typical Applications Include:

- Industrial, commercial and residential construction projects
- General maintenance and repair work (MRO) in industrial facilities
- Temporary power distribution at carnivals, circuses, fairs & similar events
- Convention centers to distribute power for exhibitions & maintenance
- Photo studios to distribute power to flash & other photographic equipment



See page 96 of the Temporary Power section for complete information on Oscar™ Boxes & Accessories



Made in the USA



Ground Fault Circuit Interrupters

Oscar™ Series Temporary Power Distribution Centers



Model 1066FS

**ERICSON OFFERS A WIDE
VARIETY OF TEMPORARY
POWER DISTRIBUTION
CENTERS FOR IN-PLANT &
CONSTRUCTION SITE USE**



Custom
Model Oscar2

Ground Fault Circuit Interrupters

Hand Held 7-Way GFCI Tester

- Hand held 7-way GFCI tester tests circuits seven critical ways
- Use on NEMA 5-15, 5-20 /120VAC 3-wire outlets and GFCI protected outlets
- Simply plug in the tester, see which lights are activated and read the easy-to-see color coded chart to identify the condition of the wiring
- When testing GFCI receptacles, simply press the thumb button to test for proper GFCI operation

Plug-In to test for:

- Open hot
- Open ground
- Open neutral
- Hot/ground reversed
- Hot/neutral reversed
- Correct wiring
- Proper GFCI operation

Selection Guide

Catalog Number	Description
1099	Hand-held 7-way GFCI tester

Indicator	Fault	Reason for wiring fault
○ ● ○	Open Ground	Ground contact not connected
○ ○ ●	Open Neutral	Neutral contact not connected
○ ○ ○	Open Hot	Hot contact not connected
● ○ ●	Hot Ground Reverse	Hot and ground contacts interchanged
● ● ○	Hot Neutral Reverse	Hot and neutral contacts interchanged
○ ● ●	Correct	Receptacle is wired correctly



RED



AMBER



Ground Fault Circuit Interrupters

Code Related Issues

Code Related Issues

2002 National Electrical Code

Article 527 Temporary Installations

Section 527.6 Ground Fault Protection for Personnel

Section 527.6(A) - Receptacle Outlets

This section requires GFCIs for all 125 volt, single phase, 15-, 20- and 30-ampere receptacle outlets that are used to supply temporary power to equipment used by personnel during construction, remodeling, demolition, maintenance, and repair activities (See figure 1). The code recognizes the use of listed "portable" devices as a means of providing GFCI protection.

Exception Permits industrial establishments, where conditions of maintenance and supervision ensure that only qualified personnel are involved, to implement a written Assured Equipment Grounding Program (AEGCP) for only those receptacle outlets used to supply equipment that would create a greater hazard if power was interrupted or having a design that is not compatible with GFCI protection.

The AEGCP consists of a series of tests and inspections that verify electrical continuity and mechanical integrity and shall be performed (a) before first use, (b) when there is evidence of damage, (c) before equipment is returned to service following any repairs, (d) at intervals not to exceed 3 months. These tests must be recorded and made available to the Authority Having Jurisdiction (AHJ).

Section 527.6(B) - Use of Other Outlets

This section requires protection for receptacle outlets other than 125 volt, 15-, 20-, and 30-ampere. This extends the requirements for protection to receptacle outlets rated over 30-amperes and those rated above 125 volts (including 208- and 240-volts). This protection can be supplied by (1) Ground Fault Circuit Interrupters or (2) A written Assured Equipment Grounding Conductor Program (AEGCP) continuously enforced at the site by designated person(s).

Section 525.23(A) - Ground Fault Circuit Interrupter Protection for Personnel; General-Use 15- and 20-Ampere, 125 Volt Receptacles

This requires GFCI protection for all 125 volt, 15- and 20-ampere receptacle outlets used by personnel at carnivals, circuses and fairs and similar events. The GFCI can be part of the attachment plug or located in the power supply cord within 12" of the attachment plug. The code recognizes the use of listed "portable" devices as a means of providing GFCI protection.

Section 525.23(C) - Ground Fault Circuit Interrupter Protection for Personnel; Other Receptacles

This section requires protection for receptacle outlets other than 125 volt, 15- and 20-ampere. This protection can be supplied by (1) Ground-fault circuit-interrupters or (2) A written program that is continuously enforced at the site...This section goes on to reference Section 527-6(B)(2) which is the Assured Equipment Grounding Conductor Program (AEGCP) (See figure 2).

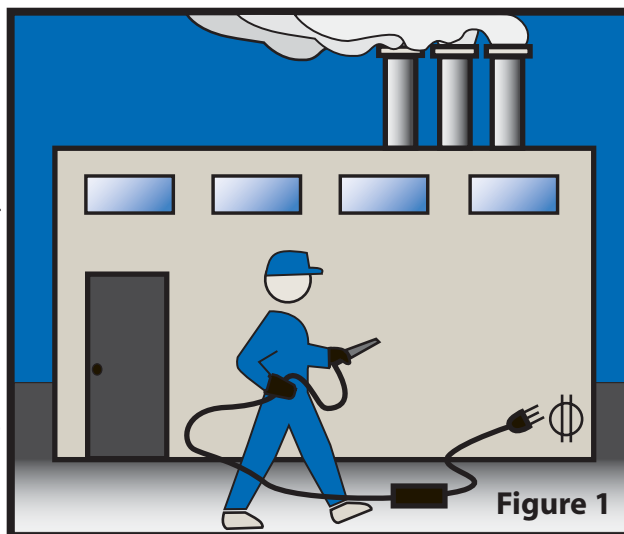

Figure 1

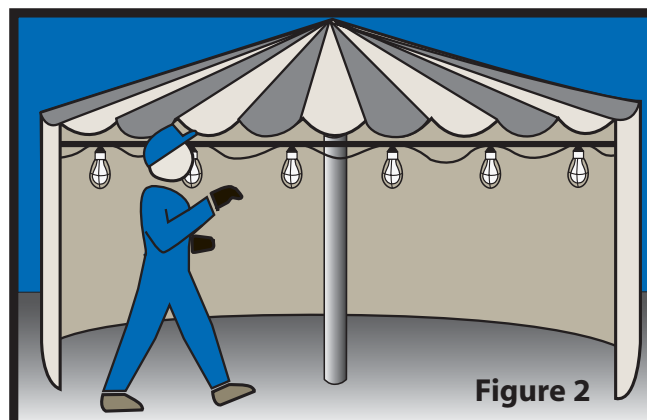

Figure 2

OSHA 1910 - Occupational Safety and Health Standards

OSHA 1910.213

Occupational Safety & Health Standards

SubPart O - Machinery & Machine Guarding, Section 213-Woodworking Machinery Requirements

OSHA 1910.213(b)(3)

On applications where injury to the operator might result if the motors were to restart after power failure, provision shall be made to prevent machines from automatically restarting upon restoration of power.

OSHA 1926 - Safety and Health Regulations for Construction

OSHA 1926.404

Wiring design and protection.

SubPart Number: K - Electrical - Installation Safety Requirements

OSHA 1926.404(b)(1)(i)

General. The employer shall use either ground fault circuit interrupters as specified in paragraph (b)(1)(ii) of this section or an assured equipment grounding conductor program as specified in paragraph (b)(1)(iii) of this section to protect employees on construction sites. These requirements are in addition to any other requirements for equipment grounding conductors.

OSHA 1926.404(b)(1)(ii)

Ground-fault circuit interrupters. All 120-volt, single-phase 15- and 20-ampere receptacle outlets on construction sites, which are not a part of the permanent wiring of the building or structure and which are in use by employees, shall have approved ground-fault circuit interrupters for personnel protection. Receptacles on a two-wire, single-phase portable or vehicle-mounted generator rated not more than 5kV, where the circuit conductors of the generator are insulated from the generator frame and all other grounded surfaces, need not be protected with ground-fault circuit interrupters.

OSHA 1926.405

Wiring Methods, components, and equipment for general use

Subpart K - Electrical

OSHA 1926.405 (a)(2)(ii)(g)

Portable electric lighting used in wet and/or other conductive locations, as for example, drums, tanks, and vessels, shall be operated at 12 volts or less. However, 120-volt lights may be used if protected by a ground-fault circuit interrupter.