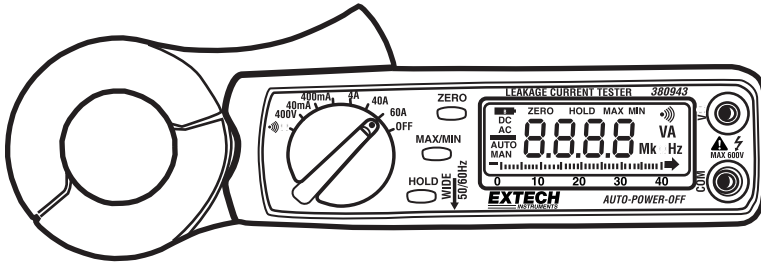

Model 380943**High Resolution 60 Amp AC Clamp-on Meter**

- 4000 Count Display with 10uA Resolution
- 20 reading per second bargraph
- Shielded transformer jaws
- Selectable filter circuit
- MAX/MIN, Relative, & Hold functions
- 1.2" (30mm) jaw diameter

Introduction

Thank you for selecting the Extech 380943 AC Clamp Meter. This device is ideal for checking leakage, ground, and sheath current. This professional meter, with proper care, will provide years of safe reliable service.

Specifications

General Specifications

Display	3-3/4 digit (4000 count) LCD with 40 segment bargraph
Functions	ACA, ACV, Resistance, and Continuity
Polarity	Minus sign (-) indicates negative polarity
Overload indication	Left blinking digit
Relative Mode	ZERO front panel key
Display rate	2 readings per second (20 readings per second for bargraph)
Battery	Two 1.5V AA batteries
Operating conditions	4 ⁰ F to 122 ⁰ F (-10 ⁰ C to 50 ⁰ C); < 85% Relative Humidity
Storage conditions	- 4 ⁰ F to 140 ⁰ F (-20 ⁰ C to 60 ⁰ C); < 75% Relative Humidity
Altitude	Operate at less than 2000 meters (Indoor use only)
Power consumption	Approximately 10mA DC
Weight	7 oz. (200g) including battery
Dimensions	8.3 x 2.4 x 1.4" (210 x 62 x 35.6mm) (HWD)
Jaw opening	1.2" (30mm)
Standards	IEC 1010 Category III 300V, Category II 600V

Range Specifications

Range / Resolution	Accuracy 50/60Hz	Accuracy 40Hz to 1Khz	Overload Protection
AC Current			
40.00mA	± (1.0% + 3 digits)	± (2.0% + 5 digits)	100A AC
400.0mA	± (1.0% + 3 digits)	± (2.0% + 3 digits)	
4.000A	± (1.0% + 3 digits)	± (2.0% + 3 digits)	
40.00A	± (1.0% + 3 digits)	± (2.0% + 3 digits)	
60.0A (0 to 50A)*	± (1.5% + 3 digits)	± (3.0% + 5 digits)	
60.0A (50 to 60A)*	± (3.0% + 5 digits)	± (3.5% + 5 digits)	
AC Voltage			
400.0V	± (1.5% + 2 digits)	± (2.0% + 4 digits)	800V AC
Resistance and Continuity			
Range	Accuracy	Audible Continuity	Overload Protection
40.0 to 400.0Ω	± (1.5% + 2d)	Beeps < 38Ω	600V AC

Specification Notes

- Open Circuit Voltage: 0.4V
- AC Voltage Input Impedance: 10MΩ
- Accuracy specified at 25°C

* Displays over 60A are possible but the accuracy of such measurements is not specified

Meter Description

1. Current sensing jaws
2. Jaws opening trigger
3. Function switch
4. Data HOLD key
5. MAX / MIN key
6. ZERO (Relative) key
7. LCD Display
8. Frequency select slide switch
9. Positive input terminal for V and Ω
10. Negative (COM) input terminal

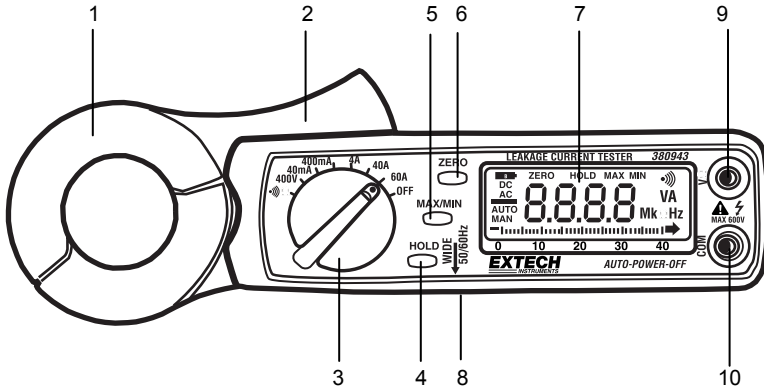

Safety Information



Caution ! Refer to the explanation in this Manual



Caution ! Risk of electric shock



Earth (Ground)



Double Insulation

This meter has been designed with safety in mind, but the operator must use caution. The rules listed below should be carefully followed for safe operation.

1. **NEVER** apply voltage or current to the meter that exceeds the specified maximum.
2. **USE EXTREME CAUTION** when working with high voltages.
3. **DO NOT** measure voltage if the voltage on the "COM" input jack exceeds 600V above earth ground.
4. **ALWAYS** turn off the power and disconnect the test leads before opening the meter to replace the fuse or the batteries.
5. **NEVER** operate the meter unless the back cover and the battery/fuse door are in place and fastened securely.

Using the Frequency Selector Switch

50/60Hz position (low pass filter)

Use the 50/60Hz position when measuring circuits with a frequency bandwidth of 50/60Hz. Since the meter has superior frequency response, measurement results may include higher frequencies and harmonics of the fundamental frequency. Putting this switch in the 50/60 position activates the meter's low pass filter minimizing the affects of high frequency noise. The filter's cut-off frequency is 100Hz with 24dB/octave attenuation (approx.).

WIDE Position (for high frequencies)

Put the slide switch in the WIDE position if the circuit under test is a high frequency generating device (up to 1KHz) such as an inverter, switching regulator, etc. To verify the presence of a high frequency signal, take measurements in both switch positions. If the readings are widely different, then a high frequency signal can be assumed present.

AC Current Measurements

Basic Current Measurement Procedure

WARNING: To avoid electric shock, disconnect the test leads from the meter before making current measurements.

1. Set the Function switch to the desired current range.
2. Set the Frequency slide switch to the appropriate position (refer to the paragraph above to determine which position to use).
3. Press the jaw trigger to open the clamp jaws and clamp around the conductor(s) ensuring they're fully enclosed by the clamp jaws.
4. Refer to the applications diagrams below for specific measurement configurations.
5. Read the ACA value on the LCD digits and the bargraph.

AC Current Applications

Load Current Measurements

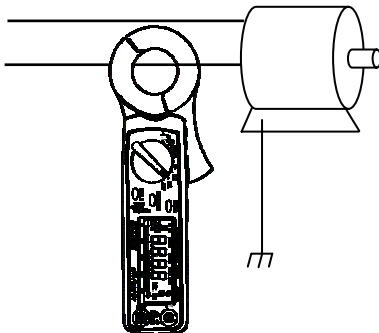

Leakage Current on Unbalanced Loads

Ground Conductor Leakage

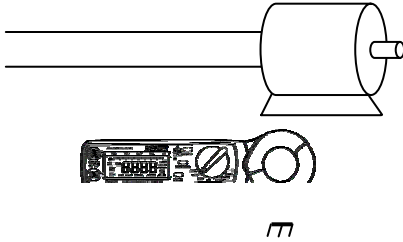

Single Phase 2-Wire Leakage

Three Phase 3-Wire Leakage

Three Phase 4-Wire Leakage

AC Voltage Measurements

WARNING: To avoid electric shock or damage to the meter, do not make any voltage measurements that exceed the maximum specified limits.

1. Set the Function switch to the Voltage position.
2. Set the Frequency Slide Switch to the appropriate position (refer to the section "Using the Frequency Slide Switch" earlier in this manual).
3. Insert the test leads to the meter as follows: Red lead to the red 'V' input terminal; Black lead to the black COM input terminal.
4. Connect the test leads to the circuit or device under test (see diagram example below).
5. Read the ACV value on the meter's display (LCD digits and bargraph).