

150X Series

Insulation Testers

Calibration Manual



LIMITED WARRANTY AND LIMITATION OF LIABILITY

Each Fluke product is warranted to be free from defects in material and workmanship under normal use and service. The warranty period is one year and begins on the date of shipment. Parts, product repairs, and services are warranted for 90 days. This warranty extends only to the original buyer or end-user customer of a Fluke authorized reseller, and does not apply to fuses, disposable batteries, or to any product which, in Fluke's opinion, has been misused, altered, neglected, contaminated, or damaged by accident or abnormal conditions of operation or handling. Fluke warrants that software will operate substantially in accordance with its functional specifications for 90 days and that it has been properly recorded on non-defective media. Fluke does not warrant that software will be error free or operate without interruption.

Fluke authorized resellers shall extend this warranty on new and unused products to end-user customers only but have no authority to extend a greater or different warranty on behalf of Fluke. Warranty support is available only if product is purchased through a Fluke authorized sales outlet or Buyer has paid the applicable international price. Fluke reserves the right to invoice Buyer for importation costs of repair/replacement parts when product purchased in one country is submitted for repair in another country.

Fluke's warranty obligation is limited, at Fluke's option, to refund of the purchase price, free of charge repair, or replacement of a defective product which is returned to a Fluke authorized service center within the warranty period.

To obtain warranty service, contact your nearest Fluke authorized service center to obtain return authorization information, then send the product to that service center, with a description of the difficulty, postage and insurance prepaid (FOB Destination). Fluke assumes no risk for damage in transit. Following warranty repair, the product will be returned to Buyer, transportation prepaid (FOB Destination). If Fluke determines that failure was caused by neglect, misuse, contamination, alteration, accident, or abnormal condition of operation or handling, including overvoltage failures caused by use outside the product's specified rating, or normal wear and tear of mechanical components, Fluke will provide an estimate of repair costs and obtain authorization before commencing the work. Following repair, the product will be returned to the Buyer transportation prepaid and the Buyer will be billed for the repair and return transportation charges (FOB Shipping Point).

THIS WARRANTY IS BUYER'S SOLE AND EXCLUSIVE REMEDY AND IS IN LIEU OF ALL OTHER WARRANTIES, EXPRESS OR IMPLIED, INCLUDING BUT NOT LIMITED TO ANY IMPLIED WARRANTY OF MERCHANTABILITY OR FITNESS FOR A PARTICULAR PURPOSE. FLUKE SHALL NOT BE LIABLE FOR ANY SPECIAL, INDIRECT, INCIDENTAL OR CONSEQUENTIAL DAMAGES OR LOSSES, INCLUDING LOSS OF DATA, ARISING FROM ANY CAUSE OR THEORY.

Since some countries or states do not allow limitation of the term of an implied warranty, or exclusion or limitation of incidental or consequential damages, the limitations and exclusions of this warranty may not apply to every buyer. If any provision of this Warranty is held invalid or unenforceable by a court or other decision-maker of competent jurisdiction, such holding will not affect the validity or enforceability of any other provision.

Fluke Corporation
P.O. Box 9090
Everett, WA 98206-9090
U.S.A.

Fluke Europe B.V.
P.O. Box 1186
5602 BD Eindhoven
The Netherlands

Table of Contents

Title	Page
Introduction.....	1
Safety Information	1
Contacting Fluke.....	2
General Specifications	3
Electrical Specifications	4
AC/DC Voltage Measurement.....	4
Earth-Bond Resistance Measurement.....	4
Insulation Specifications	4
Models 1507 and 1508	4
Model 1503	5
EN61557 Specification (Models 1503 and 1507)	5
EN61557 Influence Variables and Uncertainties (Models 1503 and 1507)	5
Insulation Resistance Maximum and Minimum Display Values (Models 1503 and 1507)	6
Earth-Bond Resistance Maximum Display Values (Models 1503 and 1507)	7
Basic Maintenance	7
Cleaning.....	7
Testing the Batteries	7
Replacing the Batteries and/or Fuse	7
Testing the Display	9
Backlight Test.....	9
Keypad Test.....	9
Disassembling and Reassembling the Tester	9
Removing the Holster	10
Removing the Battery Door.....	11
Opening the Bottom Case.....	11
Removing the PCA	11
Removing the LCD.....	12
Replacing the LCD.....	13
Reassembling the Tester.....	14
Required Tools and Equipment	15
Performance Tests.....	16
Testing the Voltage Function	16

Discharge Circuit Test.....	17
Testing the Insulation Function	17
Insulation Resistance Accuracy Tests	17
Insulation Function, External Sense.....	18
Source Voltage Accuracy Test, "R" Nominal	18
Source Voltage Accuracy Test, Open Circuit	19
I Nominal Test.....	20
I Limit Test.....	20
Testing the Ohm Function	20
Earth Bond Resistance Accuracy Tests.....	20
2-Ohm Output Current Test	21
Open Circuit Voltage Test	21
Calibration Adjustment.....	22
Calibration Adjustment Counter.....	22
Calibration Adjustment Password	22
Changing the Password	22
Restoring the Default Password	23
Keys Used in the Calibration Steps.....	24
Calibration Adjustment Procedure	24
Service and Parts.....	26

List of Tables

Table	Title	Page
1.	Symbols.....	2
2.	Required Performance Test Equipment	15
3.	Required Calibration Adjustment Equipment	15
4.	Voltage Accuracy Tests	16
5.	Insulation Resistance Accuracy Test.....	18
6.	Source Voltage Accuracy Test, R-Nominal	19
7.	Source Voltage Accuracy Test, Open Circuit	19
8.	I Nominal Test/Limit Test.....	20
9.	Earth Bond Resistance Tests	21
10.	Calibration Adjustment Steps.....	25
11.	Generic 150X Replacement Parts	27
12.	1508 Specific Parts.....	28
13.	1507 Specific Parts.....	28
14.	1503 Specific Parts.....	28

List of Figures

Figure	Title	Page
1.	Replacing the Fuse and Batteries	8
2.	Display Test	9
3.	Disassembling the Meter.....	10
4.	Insulation Terminal Clips.....	12
5.	Accessing the LCD	13
6.	Restoring the Default Password	23
7.	150X Replacement Parts	26

Introduction

The Fluke Models 1503, 1507, and 1508 are battery-powered insulation testers (hereafter, Tester or UUT). These Testers meet CAT IV IEC 61010 standards. The IEC 61010 standard defines four measurement categories (CAT I to IV) based on the magnitude of danger from transient impulses. CAT IV Testers protect against transients from the primary supply level (overhead or underground utility service).

Although this manual contains calibration information for Models 1503, 1507, and 1508, all illustrations and examples assume use of Model 1507. Table 1 provides a description of all the symbols used in this manual.

The information provided in this manual includes the following:

- Warnings and Safety Information
- Specifications
- Basic Maintenance
- Performance Test Procedures
- Calibration Adjustment Procedure
- Replaceable Parts and Accessories

The information provided in this manual should only be used by qualified personnel. For complete operating instructions and additional safety information, refer to the *1507/1503 Insulation Testers Users Manual* or the *1508 Insulation Tester Users Manual*.

Safety Information









Warning

To avoid possible electric shock or personal injury, follow these guidelines:

- **Use the Tester only as specified in this manual or the protection provided by the Tester might be impaired.**
- **Do not use the Tester or test leads if they appear damaged, or if the Tester is not operating properly. If in doubt, have the Tester serviced.**
- **Always use the proper terminal, switch position, and range for measurements before connecting Tester to circuit under test.**
- **Verify the Tester's operation by measuring a known voltage.**
- **Do not apply more than the rated voltage as marked on the Tester, between the terminals or between any terminal and earth ground.**
- **Use caution with voltages above 30 V ac rms, 42 V ac peak, or 60 V dc. These voltages pose a shock hazard.**
- **Replace the battery as soon as the low battery indicator () appears.**
- **Disconnect circuit power and discharge all high-voltage capacitors before testing resistance, continuity, diodes, or capacitance.**
- **Do not use the Tester around explosive gas or vapor.**
- **When using the test leads, keep your fingers behind the finger guards.**
- **Remove test leads from the Tester before opening the Tester case or battery door. Never operate the Tester with the cover removed or the battery door open.**

- **Comply with local and national safety requirements when working in hazardous locations.**
- **Use proper protective equipment, as required by local or national authorities when working in hazardous areas.**
- **Avoid working alone.**
- **Use only the replacement fuse specified or the protection may be impaired.**
- **Check the test leads for continuity before use. Do not use if the readings are high or noisy.**

Table 1. Symbols

	AC (Alternating Current)		Earth Ground
	DC (Direct Current)		Fuse
	WARNING: risk of electric shock.		Double Insulated
	Battery (Low battery when shown on display.)		Important information; see manual

Contacting Fluke

To contact Fluke, call:

1-888-993-5853 in USA +81-3-3434-0181 in Japan
1-800-363-5853 in Canada +65-738-5655 in Singapore
+31-402-678-200 in Europe +1-425-446-5500 from anywhere in the world

Visit Fluke's web site at: www.fluke.com

Register your Tester at: register.fluke.com

General Specifications

Maximum Voltage Applied to any Terminal	600 V ac rms or dc
Storage Temperature	-40 °C to 60 °C (-40 °F to 140 °F)
Operating Temperature	-20 °C to 55 °C (-4 °F to 131 °F)
Temperature Coefficient	0.05 x (specified accuracy) per °C for temperatures < 18 °C or > 28 °C (< 64 °F or > 82 °F)
Relative Humidity	Noncondensing 0 % to 95 % @ 10 °C to 30 °C (50 °F to 86 °F) 0 % to 75 % @ 30 °C to 40 °C (86 °F to 104 °F) 0 % to 40 % @ 40 °C to 55 °C (104 °F to 131 °F)
Vibration	Random, 2 g, 5-500 Hz per MIL-PRF-28800F, Class 2 instrument
Shock	1 meter drop per IEC 61010-1 2nd Edition (1 meter drop test, six sides, oak floor)
Electromagnetic Compatibility	In an RF field of 3 V/M, accuracy = specified accuracy (EN 61326-1:1997).
Safety	Complies with ANSI/ISA 82.02.01 (61010-1) 2004, CAN/CSA-C22.2 NO. 61010-1-04, and IEC/EN 61010-1 2nd Edition for measurement category IV 600 V (CAT IV)
Certifications	CSA per standard CSA/CAN C22.2 No. 61010.1-04; TUV per standard IEC/EN 61010-1 2nd Edition
Batteries	Four AA batteries (NEDA 15A or IEC LR6)
Battery Life	Insulation test use: Tester can perform at least 1000 insulation tests with fresh alkaline batteries at room temperature. These are standard tests of 1000 V into 1 MΩ with a duty cycle of 5 seconds on and 25 seconds off. Resistance Measurements: Tester can perform at least 2500 earth-bond resistance measurements with fresh alkaline batteries at room temperature. These are standard tests of 1 Ω with a duty cycle of 5 seconds on and 25 seconds off.
Size	5.0 cm H x 10.0 cm W x 20.3 cm L (1.97 in H x 3.94 in W x 8.00 in L)
Weight	550 g (1.2 lb)
IP Rating	IP40
Altitude	Operating: 2000 m CAT IV 600 V, 3000 m CAT III 600 V Non Operating (Storage): 12,000 m
Over-Range Capability	110% of range
Compliance to EN 61557	IEC61557-1, IEC61557-2, IEC61557-4, IEC61557-10
Model 1503 Accessories	TL224 Leads TP74 Probes Clips PN 1958654 (red) and PN 1958646 (black) Holster
Model 1507 Accessories	TL224 Leads TP74 Probes Clips PN 1958654 (red) and PN 1958646 (black) Holster Remote Probe
Model 1508 Accessories	Lead Set PN 666602 Clips PN 1670641 (red) and PN 1670652 (black) Holster Remote Probe

Electrical Specifications

AC/DC Voltage Measurement

Accuracy

Range	Resolution	50 Hz to 400 Hz ± (% of Rdg + Digits)
600.0 V	0.1 V	± (2 % + 3)

Input Impedance 3 MΩ (nominal), <100 pF

Common Mode Rejection Ratio
(1 kΩ unbalanced) > 60 dB at dc, 50 or 60 Hz

Overload Protection 600 V rms or dc

Earth-Bond Resistance Measurement

Range	Resolution	Accuracy ^[1] + (% of Rdg + Digits)
20.00 Ω	0.01 Ω	± (1.5 % + 3)
200.0 Ω	0.1 Ω	
2000 Ω	1 Ω	
20.00 kΩ	0.01 kΩ	

[1] Accuracies apply from 0 to 100% of range.

Overload Protection 2 V rms or dc

Open Circuit Test Voltage > 4.0 V, < 8 V

Short Circuit Current > 200.0 mA

Insulation Specifications

Measurement Range 0.01 MΩ to 10 GΩ models 1507 and 1508, 0.01 MΩ to 2000 MΩ model 1503

Test Voltages 50, 100, 250, 500, 1000 V models 1507 and 1508, 500 and 1000 V model 1503

Test Voltage Accuracy + 20 %, - 0 %

Short-Circuit Test Current 1 mA nominal

Auto Discharge Discharge time < 0.5 second for C = 1 μF or less

Live Circuit Detection Inhibit test if terminal voltage > 30 V prior to initialization of test

Maximum Capacitive Load Operable with up to 1 μF load

Models 1507 and 1508

Output Voltage	Display Range	Resolution	Test Current	Accuracy ± (% of Rdg + Digits)
50 V (0 % to + 20 %)	0.01 to 20.00 MΩ	0.01 MΩ	1 mA @ 50 kΩ	± (3 % + 5)
	20.0 to 50.0 MΩ	0.1 MΩ		
100 V (0 % to + 20 %)	0.01 to 20.00 MΩ	0.01 MΩ	1 mA @ 100 kΩ	± (3 % + 5)
	20.0 to 100.0 MΩ	0.1 MΩ		
250 V (0 % to + 20 %)	0.01 to 20.00 MΩ	0.01 MΩ	1 mA @ 250 kΩ	± (1.5 % + 5)
	20.0 to 200.0 MΩ	0.1 MΩ		
500 V (0 % to + 20 %)	0.01 to 20.00 MΩ	0.01 MΩ	1 mA @ 500 kΩ	± (1.5 % + 5)
	20.0 to 200.0 MΩ	0.1 MΩ		
	200 to 500 MΩ	1 MΩ		
1000 V (0 % to + 20 %)	0.1 to 200.0 MΩ	0.1 MΩ	1 mA @ 1 MΩ	± (1.5 % + 5)
	200 to 2000 MΩ	1 MΩ		
	2.0 to 10.0 GΩ	0.1 GΩ		± (10 % + 3)

Model 1503

Output Voltage	Display Range	Resolution	Test Current	Accuracy ± (% of Rdg + Digits)
500 V (0 % to + 20 %)	0.01 to 20.00 MΩ	0.01 MΩ	1 mA @ 500 kΩ	± (2.0 % + 5)
	20.0 to 200.0 MΩ	0.1 MΩ		
	200 to 500 MΩ	1 MΩ		
1000 V (0 % to + 20 %)	0.1 to 200.0 MΩ	0.1 MΩ	1 mA @ 1 MΩ	± (2.0 % + 5)
	200 to 2000 MΩ	1 MΩ		

EN61557 Specification (Models 1503 and 1507)

The following tables are a requirement for European labeling.

Measurement	Intrinsic Uncertainty	Operating Uncertainty ^[1]
Volts	± (2.0 % + 3)	30 %
Earth-Bond Resistance	± (1.5 % + 3)	30 %
Insulation Resistance	Depends on test voltage and range. See Insulation Test specifications.	30 %
[1] This specification comes from the standard and indicates the maximum amount allowable by the standard.		

EN61557 Influence Variables and Uncertainties (Models 1503 and 1507)

Earth-Bond Resistance Influence Variable	Designation per EN61557	Uncertainty for Insulation Resistance ¹	Uncertainty for Earth-Bond Resistance ^[1]
Supply Voltage	E2	5 %	5 %
Temperature	E3	5 %	5 %
[1] Specification confidence level 99 %.			

The following tables can be used to determine the maximum or minimum display values considering maximum instrument operating error per EN61557-1, 5.2.4.

Insulation Resistance Maximum and Minimum Display Values (Models 1503 and 1507)

50 V		100 V		250 V		500 V		1000 V	
Limit Value	Minimum Display Value	Limit Value	Minimum Display Value	Limit Value	Minimum Display Value	Limit Value	Minimum Display Value	Limit Value	Minimum Display Value
0.05	0.07	0.05	0.07	0.05	0.07	0.05	0.07		
0.06	0.08	0.06	0.08	0.06	0.08	0.06	0.08		
0.07	0.09	0.07	0.09	0.07	0.09	0.07	0.09		
0.08	0.10	0.08	0.10	0.08	0.10	0.08	0.10		
0.09	0.12	0.09	0.12	0.09	0.12	0.09	0.12		
0.1	0.13	0.1	0.13	0.1	0.13	0.1	0.13	0.1	0.1
0.2	0.26	0.2	0.26	0.2	0.26	0.2	0.26	0.2	0.3
0.3	0.39	0.3	0.39	0.3	0.39	0.3	0.39	0.3	0.4
0.4	0.52	0.4	0.52	0.4	0.52	0.4	0.52	0.4	0.5
0.5	0.65	0.5	0.65	0.5	0.65	0.5	0.65	0.5	0.7
0.6	0.78	0.6	0.78	0.6	0.78	0.6	0.78	0.6	0.8
0.7	0.91	0.7	0.91	0.7	0.91	0.7	0.91	0.7	0.9
0.8	1.04	0.8	1.04	0.8	1.04	0.8	1.04	0.8	1.0
0.9	1.17	0.9	1.17	0.9	1.17	0.9	1.17	0.9	1.2
1.0	1.30	1.0	1.30	1.0	1.30	1.0	1.30	1.0	1.3
2.0	2.60	2.0	2.60	2.0	2.60	2.0	2.60	2.0	2.6
3.0	3.90	3.0	3.90	3.0	3.90	3.0	3.90	3.0	3.9
4.0	5.20	4.0	5.20	4.0	5.20	4.0	5.20	4.0	5.2
5.0	6.50	5.0	6.50	5.0	6.50	5.0	6.50	5.0	6.5
6.0	7.80	6.0	7.80	6.0	7.80	6.0	7.80	6.0	7.8
7.0	9.10	7.0	9.10	7.0	9.10	7.0	9.10	7.0	9.1
8.0	10.40	8.0	10.40	8.0	10.40	8.0	10.40	8.0	10.4
9.0	11.70	9.0	11.70	9.0	11.70	9.0	11.70	9.0	11.7
10.0	13.0	10.0	13.0	10.0	13.0	10.0	13.0	10.0	13.0
20.0	26.0	20.0	26.0	20.0	26.0	20.0	26.0	20.0	26.0
30.0	39.0	30.0	39.0	30.0	39.0	30.0	39.0	30.0	39.0
40.0	52.0	40.0	52.0	40.0	52.0	40.0	52.0	40.0	53.0
		50.0	65.0	50.0	65.0	50.0	65.0	50.0	65.0
		60.0	78.0	60.0	78.0	60.0	78.0	60.0	78.0
		70.0	91.0	70.0	91.0	70.0	91.0	70.0	91.0
		80.0	104.0	80.0	104.0	80.0	104.0	80.0	104.0
		90.0	117.0	90.0	117.0	90.0	117.0	90.0	117.0
				100.0	130.0	100.0	130.0	100.0	130.0
						200.0	260.0	200.0	260.0
						300.0	390.0	300.0	390.0
						400.0	520.0	400.0	520.0
								500.0	650.0
								600.0	780.0
								700.0	910.0
								800.0	1040.0
								900.0	1170.0
								1000.0	1300.0
								2000.0	2600.0

Earth-Bond Resistance Maximum Display Values (Models 1503 and 1507)

Limit Value	Maximum Display Value	Limit Value	Maximum Display Value	Limit Value	Maximum Display Value
0.4	0.28	7.0	4.9	100.0	70.0
0.5	0.35	8.0	5.6	200.0	140.0
0.6	0.42	9.0	6.3	300.0	210.0
0.7	0.49	10.0	7.0	400.0	280.0
0.8	0.56	20.0	14.0	500.0	350.0
0.9	0.63	30.0	21.0	600.0	420.0
1.0	0.7	40.0	28.0	700.0	490.0
2.0	1.4	50.0	35.0	800.0	560.0
3.0	2.1	60.0	42.0	900.0	630.0
4.0	2.8	70.0	49.0	1000.0	700.0
5.0	3.5	80.0	56.0	2000.0	1400.0
6.0	4.2	90.0	63.0		

Basic Maintenance

This basic maintenance section of the manual contains tests and procedures that require no equipment other than the Tester and some consumables such as fuses and batteries. Also, internal access is limited to the battery and fuse compartment.

Cleaning

When cleaning is necessary, wipe the Tester with a damp cloth and mild detergent. Do not use abrasives or solvents. Dirt or moisture on the terminals can affect readings.

Testing the Batteries

⚠️⚠️ Warning

To avoid electrical shock or personal injury, replace the batteries as soon as the battery indicator (⚡) appears. A weak battery can cause false readings.

The Tester continuously monitors battery voltage. If the low battery icon (⚡) appears on the display, there is minimal battery life left. Before any performance test, check the batteries and replace if necessary.

The following procedure tests the batteries under load:

1. Turn the rotary switch to the **⚡ V** position with no probes inserted.
2. Press the blue key to initiate the fully loaded battery test. The voltage function display clears and the measured battery voltage is shown in the primary display for two seconds, the voltage display then returns. The displayed voltage should be within 5.5 to 6.2 V. If voltage is lower than 5.2 V, replace the batteries and repeat the test.

Replacing the Batteries and/or Fuse

Replace the fuse and batteries as shown in Figure 1. Follow the steps below to replace the batteries.

⚠ ⚠ Warning

To avoid shock, injury, or damage to the Tester:

- To avoid false readings, which could lead to possible electric shock or personal injury, replace the batteries as soon as the battery indicator (🔋) appears.
 - Use ONLY fuses with the amperage, interrupt, voltage, and speed ratings specified.
 - Turn the rotary switch to OFF and remove the test leads from the terminals.
1. Remove the yellow boot from the Tester. Use the thumb-hole to press on the rear of the Tester and peel the boot from the Tester.
 2. Remove the battery door by using a standard screwdriver to turn the battery door lock until the unlock symbol aligns with the arrow.
 3. Lift the bottom of the battery door away from the Tester to access the fuse and battery compartment.
 4. Remove and replace the batteries and fuse as shown in Figure 1.
 5. Replace the battery door and secure by turning the battery door lock until the lock symbol (🔒) aligns with the arrow.
 6. Position the bottom of the Tester in the bottom of the boot, and press the top of the Tester firmly into the boot.

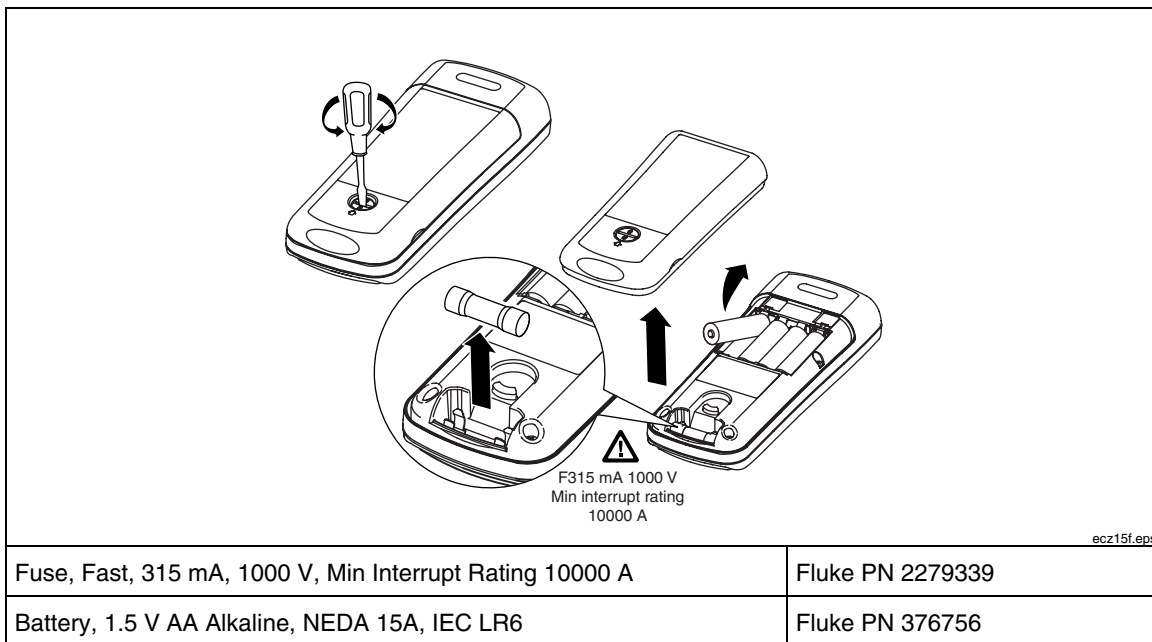

Figure 1. Replacing the Fuse and Batteries

Testing the Display

Press and hold the blue key, and simultaneously turn the UUT on. Compare the display with the example in Figure 2. Check all segments for clarity and contrast.

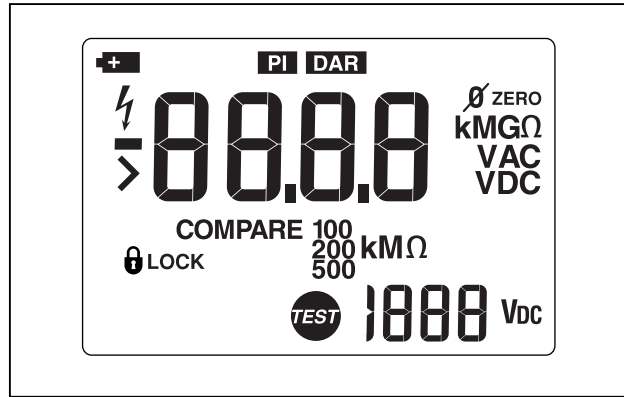





Figure 2. Display Test

bbw01f.eps

Backlight Test

The display backlight is a toggle function controlled by the  key. Each press of  causes the backlight to change states, on to off or off to on. To test the backlight:

1. Press the  key twice to verify that the toggle function is working.
2. Turn the backlight off.

Keypad Test

The keypad consists of six keys located above the rotary switch. To test the keypad:

1. Turn the rotary switch to **V** and momentarily press each of the six keys. Each press of an operational key will cause the Tester to beep. No beep in response to a key press indicates a defective keypad.
2. Reset the Tester by turning it **OFF**, and then to any other position.

Disassembling and Reassembling the Tester

This section of the manual provides instructions for disassembling and reassembling the Tester. The instructions are limited to major replaceable assemblies and do not include component-level detail. See Figure 3 for an exploded view of the major assemblies. Also, the emphasis is placed on disassembly. However, when appropriate, an italicized entry at the end of each disassembly procedure provides critical hints for reassembly.

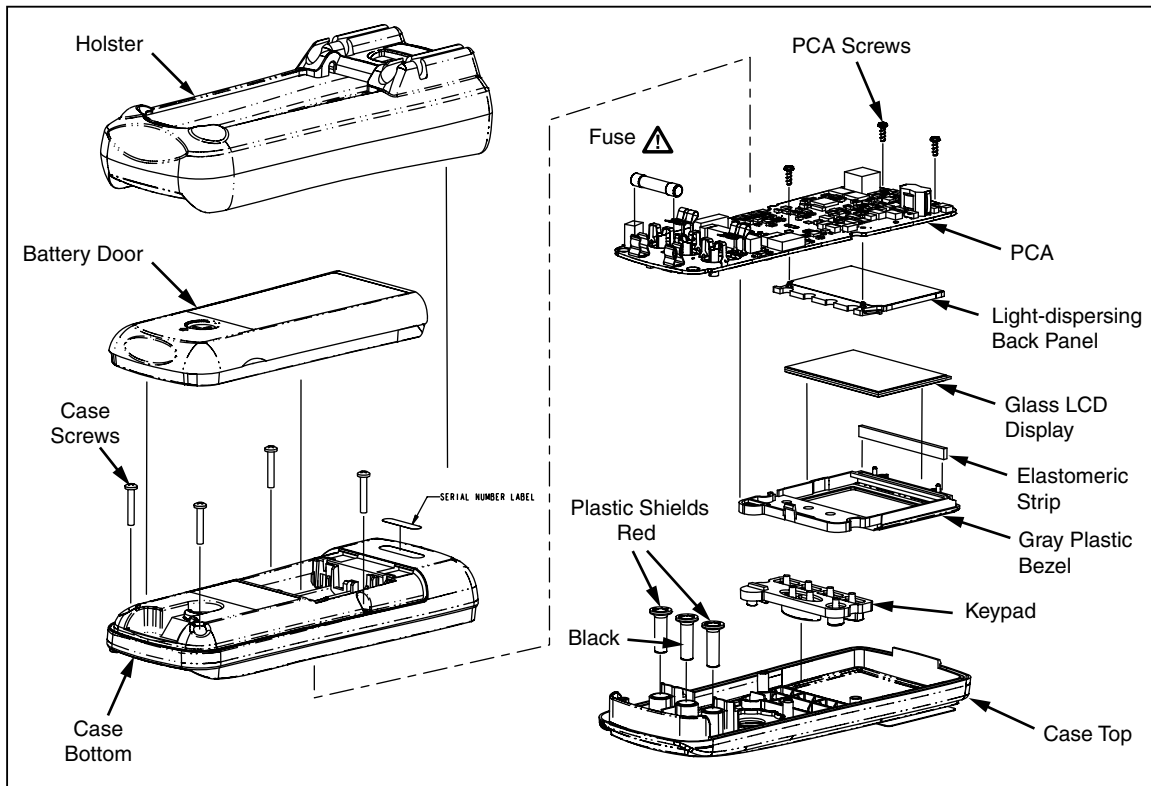

ecz20f.eps

Figure 3. Disassembling the Tester

Removing the Holster

The standard Tester comes equipped with a snug-fitting yellow rubber holster. The holster helps protect the Tester from rough handling and normally remains on the Tester. The first step in disassembling the Tester is to remove the holster.

Use the following procedure to remove the holster:

1. Looking at the Tester, place your thumbs on the top corners of the holster and firmly grasp the Tester.
2. Using both thumbs, push the holster up and over both corners of the Tester.
3. Continue pushing on the holster until both of its inside corners are resting on top of the Tester.
4. Rest the heel of one hand behind the display, and place all four fingers of the same hand along the upper front edge of the holster.
5. Firmly grasp the Tester with the other hand, and using your fingers, peel the holster over the top of the Tester.
6. Slide the Tester up and out of the holster.

Note

To install the holster, position the bottom of the Tester in the bottom of the holster, and press the top of the instrument firmly into of the holster.

Removing the Battery Door

⚠⚠ Warning

To avoid the risk of electrical shock, turn the rotary switch to OFF, and remove the test leads from the front-panel terminals before removing the battery cover.

With the boot removed, the next step in disassembling the Tester is to remove the battery door. Use the following procedure to remove the door:

1. Locate the black slotted lock on the lower rear of the Tester.
2. Using a standard screwdriver, turn the battery-door lock until the unlock symbol aligns with the arrow. The door is now unlocked.
3. Lift the bottom of the battery door away from the Tester. Removing the battery door provides access to the fuse and battery compartment.
4. If necessary, remove and replace the batteries and fuse as shown in Figure 1.

Note

To install the battery door, slide the top of the door into position and secure it by turning the battery door lock until the lock symbol (🔒) aligns with the arrow.

Opening the Bottom Case

With the battery door removed, the next step in disassembling the Tester is to remove the bottom case. Use the following procedure to remove the bottom case:

Note

When removing the back cover, it is unnecessary to remove the fuse or the batteries.

1. Locate the four Philips head screws on the bottom case (two are next to the batteries and two are next to the fuse).
2. Using a Philips screwdriver, remove the four screws.
3. Separate the front and bottom cases at the fuse-end the Tester. Tilt the freed end of the cover up, and lift it away from the top case.

Note

To install the bottom case, first, position and press together the display-end of the top and bottom cases. Before installing all four screws, press the fuse-end of the covers together.

Removing the PCA

With the bottom case removed, the next step in disassembling the Tester is to remove the printed circuit assembly (PCA). Refer to Figure 3 for the exploded part view and use the following procedure to remove the PCA:

1. One Philips screw attaches the PCA to the top case. Locate the screw near the center of the PCA, and remove it.
2. Two chrome plated springs on the PCA form an electrical connection (clip) to the two recessed INSULATION(+) terminals on the top case. Break these connections by carefully pulling each of the springs back and away from the terminals. See Figure 4.

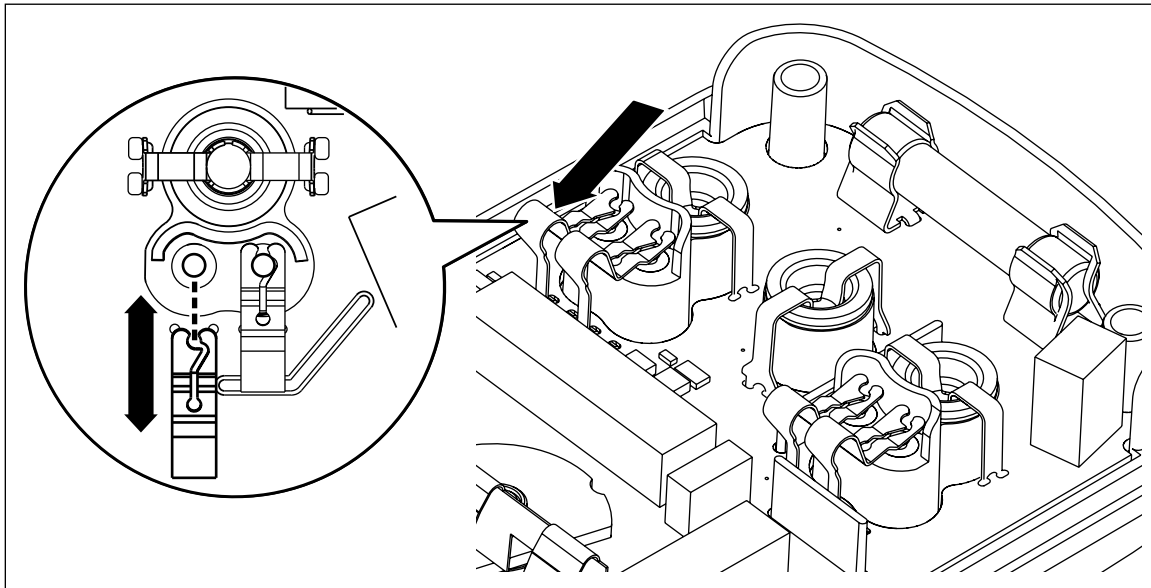

eca18f.eps

Figure 4. Insulation Terminal Clips

3. With one hand over the PCA, roll the top case over (face up) and lift it away from the PCA.

Note

Two red and one black plastic shields are used to isolate the user from the input terminals. With the PCA removed, these shields are loose and can fall away from the PCA.

4. Remove and set aside all three shields for use during reassembly.

⚠ ⚠ Warning

To avoid risk of electrical shock, make sure the plastic input terminals are properly positioned on the PCA before attaching it to the top case.

To install the PCA, proceed as follows:

1. With the PCA face-up, place all three plastic shields into position on the PCA.
2. Lower the top cover onto the PCA, and roll both parts over (PCA up).
3. Connect (snap) the chrome plated springs to the **INSULATION** terminals.
4. Install the screw that attaches the PCA to the top case.

Removing the LCD

With the PCA removed, the final step in disassembling the Tester is to remove the LCD assembly from the PCA. Refer to Figure 5 and use the following procedure to remove the LCD assembly:

1. Remove the two screws from the display end of the PCA.
2. Hold the PCA face down with the fuse-end of the PCA toward you. Locate the screw-hole near the center of the assembly. This hole is the one used to attach (with a screw) the PCA to the top case.

3. Locate the gray plastic tab just above and to the left of the hole. Using your thumbnail, press the tab down and toward the display end of the PCA. This will release the LCD assembly from the PCA.

⚠ Caution

To avoid damaging the plastic guide pins on the LCD assembly, keep the LCD assembly parallel to the PCA when separating the two parts.

4. Without tilting the PCA, lift it straight up and away from the LCD assembly.
5. To keep loose parts from falling away from the LCD assembly, keep it face-down, and set it in a safe place.

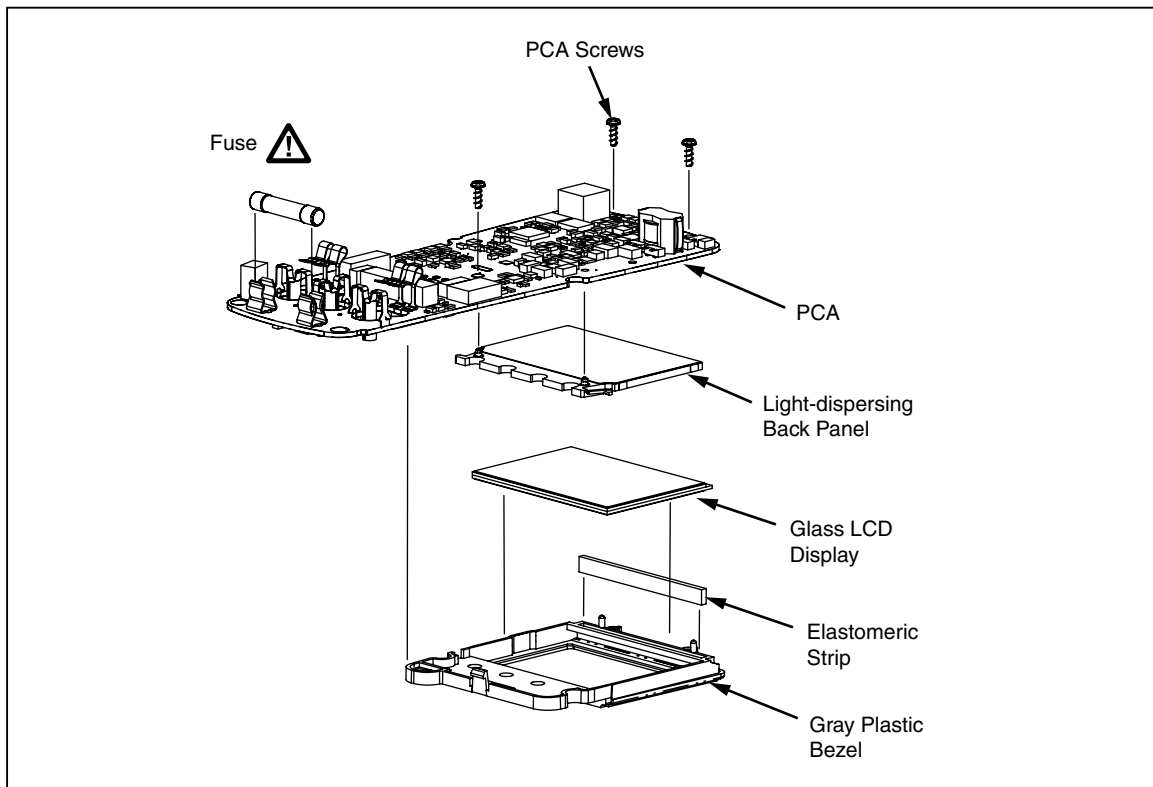

Figure 5. Accessing the LCD

ecz21f.eps

Replacing the LCD

The LCD assembly consists of four pieces as shown in Figure 5:

- Translucent light-dispersing back panel
- Flexible elastomeric conducting strip
- Plastic bezel for housing the assembly's components
- Glass LCD display

With the LCD assembly removed from the PCA, use the following procedure to replace the LCD:

1. Lift the translucent light dispersing back panel from the plastic bezel.
2. Remove the pink and black elastomeric strip from its slot in the bezel.

3. Remove the old glass LCD display from the bezel.

Note

Make sure the new LCD display is clean (free of lint and fingerprints) before placing it in position in the bezel.

4. Position the new glass LCD display in the bezel; the silver face should face the rear, and the stepped portion of the glass should be directly under the elastomeric slot on the bezel.
5. Drop the elastomeric strip into its slot on the bezel.
6. Position the translucent light-dispersing back panel over the silver side of the glass LCD display. Make sure the guide pins on the light dispersing back panel are facing up and that they are on the side opposite the elastomeric strip.
7. While holding the LCD assembly (face down) in one hand, position the PCA (fuse side up) over the bezel; match the guide holes in the PCA with the plastic guide pins on the bezel and the translucent light dispersing back panel. After the LCD assembly is in position, lock it in place by pressing (below the display) the bezel against the PCA; listen for the tab on the bezel to snap (lock) into position on the PCA.
8. Secure the PCA to the LCD assembly by installing the two screws that attach the PCA to the bezel. These screws also ensure contact between the glass LCD display, the elastomeric strip, and the PCA.

Reassembling the Tester

To reassemble the Tester, logically reverse the previous disassembly procedures. In the process, make sure to re-establish all electrical connections; specifically, the elastomeric strip for the LCD, the red and black plastic shields for the input terminals, and the two spring contacts for the Insulation Test Probe. Also make sure all parts are correctly aligned and positioned; do not force-fit any of the parts into position.

Required Tools and Equipment

Tables 2 and 3 list the required equipment used in the Performance Test and Calibration Adjustments. If a recommended model is unavailable, use a substitute with equivalent or better specifications.

Table 2. Required Performance Test Equipment

Equipment	Required Characteristics	Recommended Model
Calibrator	AC Voltage Range: 0 – 600 V Accuracy: ± 0.5 % Frequency Range: 50 Hz – 400 Hz Accuracy: ± 3 % DC Voltage: 0 – 600 V Accuracy: ± 0.5 % Ω Range: 0 – 20 kΩ Accuracy: ± 0.37 % Insulation Resistance: 50 kΩ – 10 GΩ Accuracy: ± 0.37 %	Fluke 5320A/VLC
Meter Function	DC Volts: 0 – 1500 V Accuracy: ± 5 % DC Current: 0 – 2 mA Accuracy: ± 1 %	
Ohm Meter	Ω Range: 2000 – 3000 Ω	Fluke 189

Table 3. Required Calibration Adjustment Equipment

Equipment	Required Characteristics	Recommended Model
Calibrator	DC Voltage: 0 – 750 V Accuracy: ± 5 % DC Current: 0 – 2 mA Accuracy: ± 0.37 %	Fluke 5520A
Precision Resistor	Resistor, Wirewound, 2 Ω k, ± 0.1 %, 1 W, 50 ppm	IRC PN RWR89S2R00BR

Performance Tests

The following series of tests comprise a performance test for verifying the accuracy of the Tester (UUT) and its performance level. The performance test is recommended as an acceptance test for incoming inspection and as a calibration procedure for periodically ensuring the accuracy of the Tester. Fluke recommends running the performance test at least once a year.

No adjustments are required during the performance test, and it is not necessary to open the case. If the Tester does not pass all parts of the performance tests, repair and/or calibration adjustment are required. A calibration adjustment procedure is given later in this manual. If significant repairs are required, contact Fluke as described toward the front of this manual. If user repairs are appropriate, refer to the list of user-replaceable parts toward the end of this manual.

Testing the Voltage Function

To verify the accuracy of the voltage measuring function, do the following:

1. Turn the UUT rotary switch to the **V** function.
2. Connect the Fluke 5320A voltage output terminals to the **INSULATION** and **COM** terminals of the UUT.
3. Set the 5320A for the voltage output function ($\overline{\text{V}}$).
4. Apply the input level for each step listed in Table 4.
5. Compare the reading on the UUT display with the Display Reading in Table 4.
6. If the display reading falls outside of the limits shown in Table 4, the Tester does not meet specification.

Table 4. Voltage Accuracy Tests

Step	Function	Range	Applied Input	Display Reading	
				Low Limit	High Limit
1	V	600.0 V	3 V, 0 Hz	2.7	3.3
2			8 V, 0 Hz	7.5	8.5
3			8 V, 400 Hz	Display must show V ac annunciator	
4			50 V, 0 Hz	48.7	51.3
5			100 V, 0 Hz	97.7	102.3
6			250 V, 0 Hz	244.7	255.3
7			500 V, 0 Hz	489.7	510.3
8			120 V, 60Hz	117.3	122.7
9			230 V, 50 Hz	225.1	234.9
10			600 V, 400 Hz	587.7	612.3

Discharge Circuit Test

The following Discharge Circuit Test is a safety related test that verifies input jack wiring to the PCA, the RSOB contacts, RSOB PCA pads, and other active discharge components on the PCA.

1. Place a Shorting Bar across the UUT **COM** and **INSULATION** input terminals.
2. Set the UUT rotary switch to 1000 V, and press **TEST**.
3. Release the **TEST** key and remove the short from the UUT input terminals.

⚠ Caution

To avoid damage to the DMM, DO NOT press the UUT **TEST key during the following steps.**

4. Connect the test DMM to the UUT **INSULATION** and **COM** terminals.
5. Set the test DMM to Ω function.
6. Verify that the test DMM reading is between 2000 and 3000 Ω .

Testing the Insulation Function

⚠⚠ Warning

To avoid possible electric shock or personal injury, avoid contact with the UUT when testing the insulation function. Pressing the **TEST key produces a potentially dangerous voltage, at the UUT insulation output terminals, when the Tester is in the Insulation function.**

⚠ Caution

To avoid damage to the calibrator, do not attempt to use the 5500A, 5520A or other standard calibrator for the insulation tests.

⚠ Caution

To avoid damage to the Fluke 5320A, make sure to select the High Ohms function prior to pushing the UUT **TEST key.**

Insulation Resistance Accuracy Tests

To test the insulation resistance accuracy, complete the test steps in Table 5 using the following procedure:

1. Connect the UUT **INSULATION** and **COM** terminals to the Fluke 5320A High Resistance output terminals.
2. Set the Fluke 5320A to the high resistance source function (**HI Ω**).
3. Turn the UUT rotary function switch to an **INSULATION** function.
4. Select the UUT insulation voltage range per Table 5.
5. Apply the Fluke 5320A output called out in Table 5.
6. Press the UUT **TEST** key.
7. Verify that the UUT reading is within the display reading limits listed in Table 5.

Table 5. Insulation Resistance Accuracy Test

Step	Insulation Voltage Range	Applied	Display Units	Display Reading Limits	
				1503	1507/1508
1	1000 V	9 GΩ	MΩ	N/A	7.8 to 10.2
2	1000 V	1.9 GΩ		1862 to 1938	N/A
3	1000 V	1 MΩ		0.5 to 1.5	0.5 to 1.5
4	1000 V	49 MΩ		47.5 to 50.5	47.8 to 50.2
5	1000 V	60 MΩ		58.3 to 61.7	58.6 to 61.4
6	500 V	500 kΩ		0.44 to 0.56	0.44 to 0.56
7	250 V	250 kΩ		N/A	0.20 to 0.30
8	100 V	100 kΩ		N/A	0.6 to 0.15
9	50 V	50 kΩ		N/A	0.0 to 0.10

Insulation Function, External Sense

The following test verifies that the Tester will sense a voltage > 30 V when present on the circuit under test.

1. Connect the UUT **INSULATION** and **COM** output terminals to the Fluke 5320A voltage output terminals.
2. Set the 5320A to the voltage output function (\overline{V}).
3. Turn the UUT rotary function switch to an insulation function.
4. Apply 35 V, 50 Hz to the UUT.
5. Verify that the UUT displays > 30 V in the primary display, and the red LED lightning bolt comes on.

Source Voltage Accuracy Test, "R" Nominal

Complete the test steps in Table 6 to verify source voltage of the insulation function under load. If using the Fluke 5320A, use the high resistance function to verify source voltage.

1. Connect the Fluke 5320A high resistance output terminals to the UUT **INSULATION** and **COM** terminals.
2. Put the Fluke 5320A in the high resistance function ($\overline{H\Omega}$).
3. Set the Fluke 5320A for the applied load shown in Table 6 for Steps 1-5.
4. Press \overline{TEST} and verify that the UUT and Fluke 5320A voltage readings are within the limits of Table 6. Record both of these readings.
5. Using the Fluke 5320A voltage reading as the reference, calculate the UUT voltage reading error %, $(5320A\ V - UUT\ V / 5320A\ V) \times 100$, and record for later use.

Table 6. Source Voltage Accuracy Test, R-Nominal

Step	UUT Function	Tester Range	Applied Load	5320A Display Reading	UUT Display Reading	UUT Voltage Reading Error %
1	Insulation	1000 V	1 MΩ	1000 V to 1200 V	1000 V to 1200 V	
2	Insulation	500 V	500 k	500 V to 600 V	500 V to 600 V	
3	Insulation (1507/1508)	250 V	250 kΩ	250 V to 300 V	250V to 300 V	
4	Insulation (1507/1508)	100 V	100 kΩ	100 V to 120 V	100 V to 120 V	
5	Insulation (1507/1508)	50 V	50 kΩ	50 V to 60 V	50 V to 60 V	

Source Voltage Accuracy Test, Open Circuit

The open circuit source voltage accuracy can be determined, by calculation, using the UUT Voltage Reading Error % previously noted. Complete the following test to verify the actual open circuit source voltage.

1. Remove test leads from the UUT terminals.
2. Set the UUT rotary function switch to an insulation test function.
3. Press **TEST** and record the UUT display reading for each step in Table 7.
4. Using the previously determined UUT Voltage Reading Error %, calculate the actual open circuit output voltage for each voltage range. Verify that the calculated value is within the limits shown in Table 7. The formula is Recorded UUT Display Reading x UUT Voltage Reading Error % + Recorded UUT Display Reading.

Table 7. Source Voltage Accuracy Test, Open Circuit

Step	Function	Range	Recorded UUT Display Reading	Calculated UUT Output Voltage Limits
1	Insulation	1000 V		1000 V to 1200 V
2	Insulation	500 V		500 V to 600 V
3	Insulation (1507/1508)	250 V		250 V to 300 V
4	Insulation (1507/1508)	100 V		100 V to 120 V
5	Insulation (1507/1508)	50 V		50 V to 60 V

I Nominal Test

The following test verifies the UUT's ability to maintain the nominal insulation test current while loaded.

1. Connect the Fluke 5320A high resistance output terminals to the UUT **INSULATION** and **COM** terminals.
2. Set the 5320A to the high resistance source function ($\overline{\text{HI}\Omega}$).
3. Set the 5320A for the Applied Load called out in Table 8 for Steps 1-5.
4. Press TEST and verify that the Fluke 5320A current reading is $> 1000.0 \mu\text{A}$ for steps 1-5.

Table 8. I Nominal Test/Limit Test

Step	Function	Range	Applied Load	5320A Current Reading
1	Insulation	1000 V	1 M Ω	$> 1000.0 \mu\text{A}$
2	Insulation	500 V	500 k Ω	
3	Insulation (1507/1508)	250 V	250 k Ω	
4	Insulation (1507/1508)	100 V	100 k Ω	
5	Insulation (1507/1508)	50 V	50 k Ω	$> 1000.0 \mu\text{A}$

I Limit Test

The following test verifies the UUT's internal insulation function and current limit operation.

1. Connect the Fluke 5320A high resistance output terminals to the UUT **INSULATION** and **COM** terminals.
2. Set the Fluke 5320A to the high resistance source function ($\overline{\text{HI}\Omega}$) and 50 k Ω .
3. Set the UUT rotary switch to the 1000 V range.
4. Press and hold the TEST key.
5. The Fluke 5320A current reading should be $< 2000.0 \mu\text{A}$.

Testing the Ohm Function

Earth Bond Resistance Accuracy Tests

To test earth bond resistance accuracy, complete the test steps in Table 9, using the following procedure:

1. Connect the UUT **COM** and Ω terminals to the Fluke 5320A low resistance output terminals in a 4-wire configuration.
2. Set the Fluke 5320A to the low resistance source function ($\overline{\text{LO}\Omega}$).
3. Turn the UUT rotary function switch to the Ω function.
4. Apply the calibrator output listed in Table 9, Steps 1-3.

5. Press **TEST**, and verify that the UUT reading is within the display reading limits shown in Table 9.
6. Connect the Fluke 5320A high resistance output terminals to the UUT **COM** and **Ω** terminals.
7. Set the Fluke 5320A to the high resistance source function (**HIΩ**).
8. Press **TEST**, and verify that the reading is within the display reading limits for Table 9, Step 4.

Table 9. Earth Bond Resistance Tests

Step	Tester Range	Applied	Display Units	Display Reading	
				Low Limit	High Limit
1	20.00 Ω	2.0 Ω	Ω	1.94	2.06
2	2000 Ω	810.0 Ω	Ω	795	825
3	2000 Ω	990.0 Ω	Ω	972	1008
4	20.00 kΩ	18.0 kΩ	kΩ	17.70	18.30

2-Ohm Output Current Test

The following procedure verifies the minimum current for a 2-Ω Load in continuity function:

1. Connect the Fluke 5320A low resistance output terminal to the UUT **COM** and **Ω** terminals.
2. Set the Fluke 5320A to the low resistance source function (**LOΩ**) and 2-Ω output.
3. Set the UUT rotary function switch to the **Ω** function.
4. Press the UUT **TEST**. The Fluke 5320A current reading should be > 200 mA.

Open Circuit Voltage Test

The following test confirms that the open circuit voltage for the UUT **Ω** function is within limits.

1. Connect the Fluke 5320A **V** and **COM** meter terminals directly to the UUT **Ω** and **COM** terminals observing correct polarity.
2. Set the Fluke 5320A to the **METER** mode and dc volts.
3. Set the UUT rotary function switch to the **Ω** function.
4. Press **TEST** and verify that the Fluke 5320A voltage reading is > 4.0 V but < 8.0 V.

Calibration Adjustment

The Tester features closed-case calibration adjustment using known reference sources. The Tester measures the applied reference source, calculates correction factors and stores the correction factors in nonvolatile memory.

The following sections present the features and Tester function keys that are used during the calibration adjustment procedure. Perform the calibration adjustment procedure should the Tester fail any performance test listed earlier in this manual.

Calibration Adjustment Counter

The Tester contains a calibration adjustment counter. The counter is incremented each time a calibration adjustment procedure is completed. The value in the counter can be recorded and used to show that no adjustments have been made during a calibration cycle.

Use the following steps to view the Tester's calibration counter.

1. While holding down **LOCK**, turn the rotary function switch from OFF to V. The Tester displays **CAL**.
2. Press the blue key **□** once to see the calibration counter. For example **n003**.
3. Turn the rotary function switch to OFF.

Calibration Adjustment Password

Enter the correct four-key password to start the calibration adjustment procedure. The password can be changed or reset to the default as described in the following paragraphs. The default password is **1234**.

Changing the Password

Use the following steps to change the Tester's password:

1. While holding down **LOCK**, turn the rotary function switch from OFF to V. The Tester displays **CAL**.
2. Press the blue key once to see the calibration counter.
3. Press the blue key again to start the password entry. The Tester displays ----.
4. The Tester's keys represent the digits indicated below when entering or changing the password:

Blue Key = 1 **LOCK** = 2 **⊗** = 3 **TEST** = 4

5. Press the four keys to enter the old password. If changing the password for the first time, press the blue key (1), **LOCK** (2), **⊗** (3), **TEST** (4).
6. Press **⊗** to change the password. The Tester displays ---- if the old password is correct. If the password is not correct, the Tester emits a double beep, displays ---- and the four key password must be entered again. Repeat step 4.
7. Press the four keys of the new password.
8. Press the blue key to store the new password.

Restoring the Default Password

If you forget the calibration password, the default password (1234) can be restored using the following steps.

⚠ ⚠ Warning

To avoid electrical shock or personal injury, remove the test leads and any input signal before removing the Tester's bottom case.

1. Remove the back case from the UUT. Leave the PCA in the top case.
2. Apply 6.0 V across the battery contact pads (J8) + and – on the PCA. See Figure 6.
3. Short across the Cal keypad (S8) on the back of the PCA. See Figure 6.
4. Turn the rotary knob from **OFF** to **V**. The UUT will beep and display **CAL**. The default password is now restored.
5. Remove the 6.0 V supply, turn the rotary switch to **OFF**, and install the back case on the UUT.

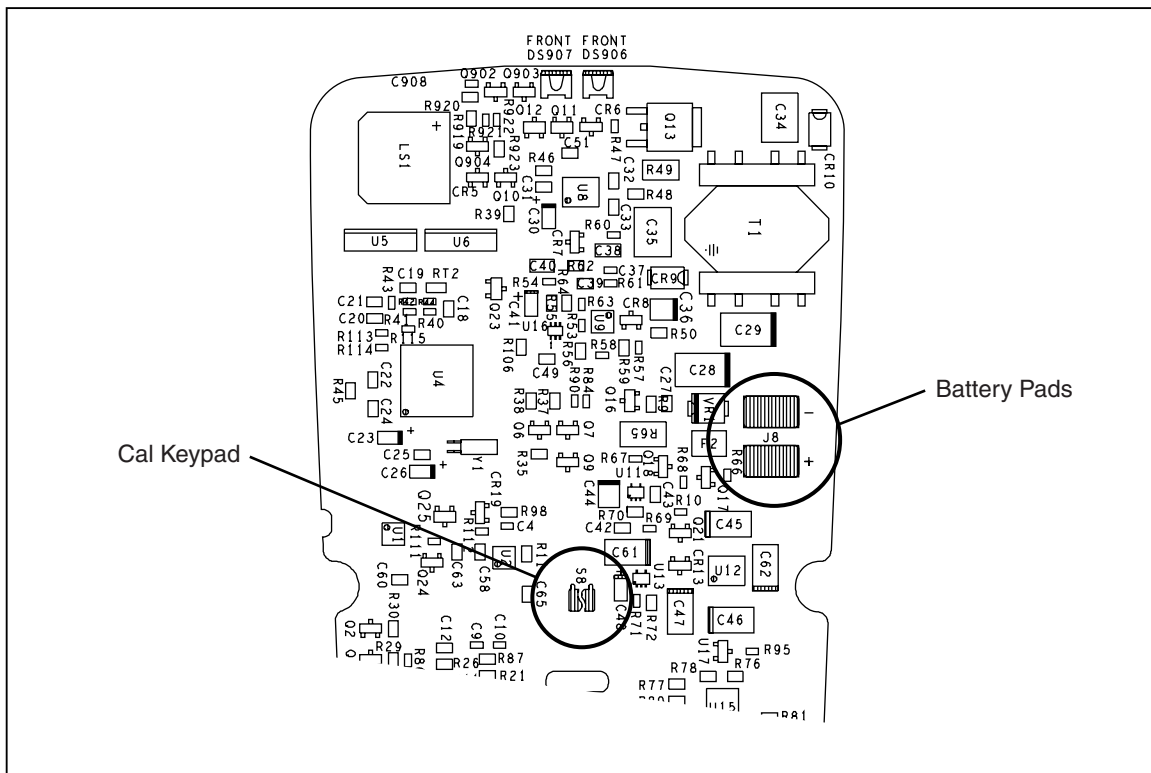



Figure 6. Restoring the Default Password

ecz17f.eps

Keys Used in the Calibration Steps

The Tester keys behave as follows when you perform the calibration adjustment procedure:

-  stores the calibration value and advances to the next step.
-  ignores the calibration value and advances to the next step. This key is also used to exit the calibration function after the calibration adjustment sequence is complete.

Calibration Adjustment Procedure

Use the following steps to make calibration adjustments to the Tester. If the Tester is turned off before completion of the adjustment procedure, the calibration constants are not changed.

1. Remove batteries from UUT battery compartment. Connect a + 5.0 V lab supply to the + and – battery terminals.
2. While holding down **LOCK**, turn the rotary function switch from OFF to VAC. The Tester displays **CAL**.
3. Press the blue button once to see the calibration counter.
4. Press blue button again to start the password entry. ---- appears on the display.
5. Press four keys to enter the password.
6. Press the blue button to go to the first calibration step. The Tester displays **C-01** if the password is correct. If the password is not correct, the Tester emits a double beep, displays ---- and the password must be entered again. Repeat step 4.
7. Using Table 10, apply the input value listed for each calibration adjustment step. For each step, position the rotary function switch and apply the input to the terminals as indicated in Table 10.
8. After each input value is applied, press  to accept the value and proceed to the next step (**C-02** and so forth).

Note

After pressing , wait until the step number advances before changing the calibrator source or turning the Tester rotary function switch. If the Tester rotary function switch is not in the correct position, or if the measured value is not within the anticipated range of the input value, the Tester emits a double beep and will not continue to the next step. Some adjustment steps take longer to execute than others (10 to 15 seconds). For these steps, the Tester will beep when the step is complete. Not all steps have this feature.

9. After the final step, the display shows **End** to indicate that the calibration adjustment is complete. Press  to go to meter mode.

Note

Set the calibrator to standby prior to changing the function switch position and or after completing adjustment of each function. If the calibration adjustment procedure is not completed correctly, the Tester will not operate correctly.

Table 10. Calibration Adjustment Steps

Switch Position	Input Terminal	Adjustment Step	Input Value
1000 V Insulation	+ : COM - : A gnd (remote test probe pin)	[- 01]	0m A, 0 Hz
		[- 02]	15u A, 0 Hz
		[- 03]	0.18 mA, 0 Hz
		[- 04]	1.8 mA, 0 Hz
Continuity		[- 05]	0.5 mA, 0 Hz
		[- 06]	5.0 mA, 0 Hz
		[- 07]	0.5 mA, 0 Hz
		[- 08]	5.0 mA, 0 Hz
		[- 09]	5.0 mA, 0 Hz
		[- 10]	300 mA, 0 Hz
Volts	+ : Volts Input	[- 11]	25.0 V, 0 Hz
	- : COM	[- 12]	750 V, 0 Hz
Continuity	+ : Continuity Input	[- 13]	0.5 V, 0 Hz
	- : COM	[- 14]	5.0 V, 0 Hz
1000 V Insulation	None	[- 15]	
Continuity	+ : Continuity Input - : COM	[- 16]	2.00 Ω (Use external resistor, 0.1 %, 1 W, 50 PPM) [1]
Any	+ : Battery + Terminal - : Battery - Terminal	[- 18]	+ 5 V
[1] Must certify that this resistor is within 1.998 Ω to 2.002 Ω . This resistor should be mounted directly to the Tester Ω and COM terminals to minimize lead resistance.			

Service and Parts

User service is limited to replacing parts. Table 11 identifies the replacement parts used by all models, Tables 12, 13, and 14 identify the replacement parts unique to each model. Figure 7 shows the location of each part. To order replacement parts refer to *Contacting Fluke* earlier in this manual.

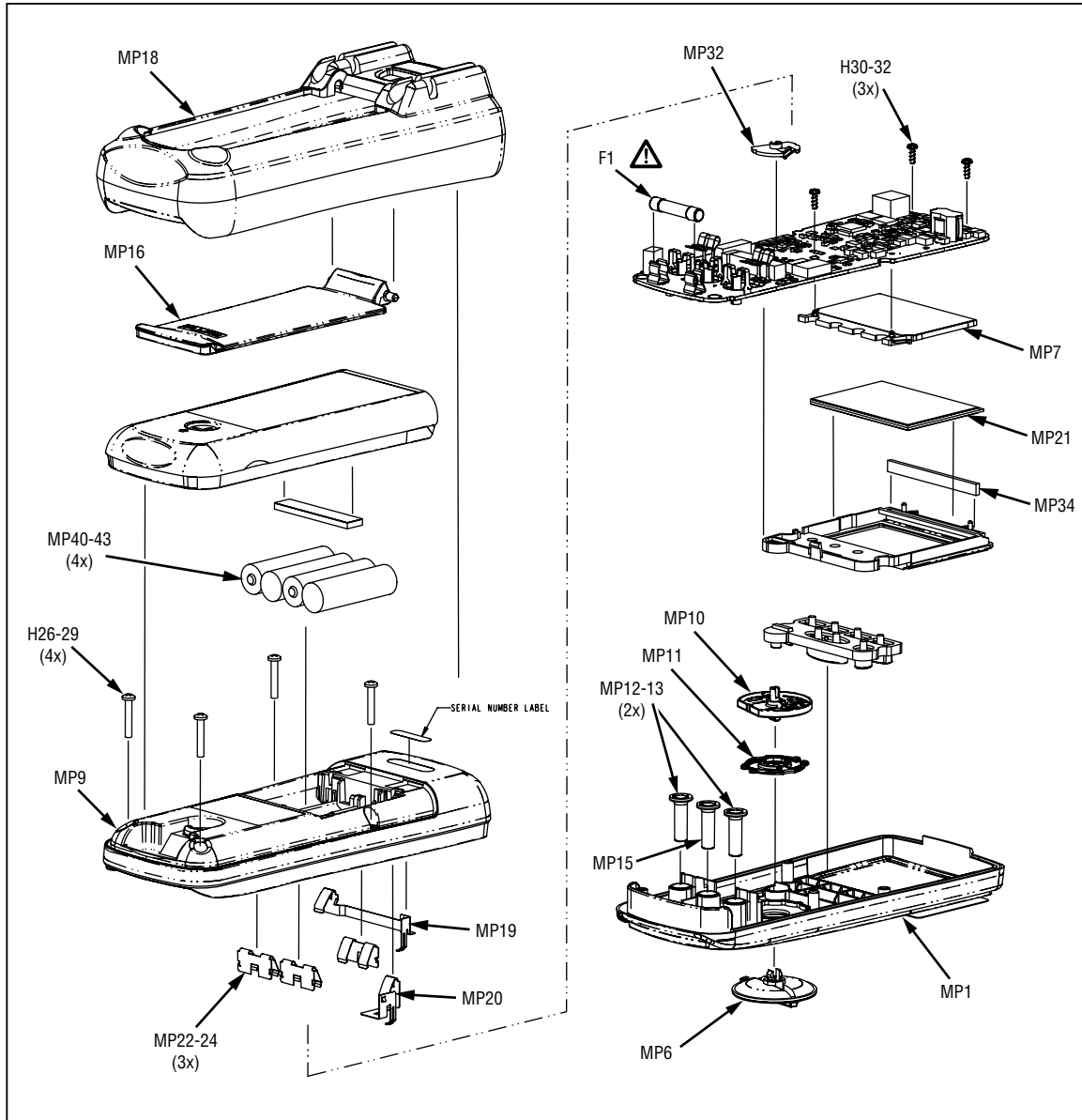

Figure 7. 150X Replacement Parts

ecz19f.eps

Table 11. Generic 150X Replacement Parts

Ref Des	Description	P/N	Qty
MP4	102-406-003,PROBE CAP,GS-38 RED	1942029	1
MP6	FLUKE-15X7-8008,KNOB	2278007	1
MP7	FLUKE-15X7-8001,FLUKE-15X7-8001, BACKLIGHT	2168609	1
MP9	FLUKE-1508-8003-02,BOTTOM CASE	2388589	1
MP10	FLUKE-15X7-8009,HOUSING ASSY,RSOB	2278018	1
MP11	FLUKE-15X7-8010,DETENT SPRING	2278029	1
MP12-13	FLUKE-15X7-8011,INSULATOR,RECEPTACLE, RED	2278128	2
MP15	FLUKE-15X7-8011-01,INSULATOR,RECEPTACLE, BLACK	2278137	1
MP16	FLUKE-15X7-8012,TILT STAND	2278143	1
MP18	FLUKE-15X7-8014,HOLSTER	2278162	1
MP19	FLUKE-15X7-8016,BATTERY CONTACT,NEG	2281317	1
MP20	FLUKE-15X7-8017,BATTERY CONTACT,POS	2281321	1
MP21	LCD,TN,3.0V,TRANSFLECTIVE,1/4-DUTY,1/3-BIAS	2156884	1
MP22-24	FLUKE 89-4-8012 ,BATTERY CONTACT, DUAL	666435	3
MP40-43	BATTERY,PRIMARY,MNO2-ZN,1.5V,2.24AH,15A,LR6,ALKALINE,AA,14X50MM,BULK	376756	4
H26-29	SCREW,5-14,,750,PAN,PHILLIPS,STEEL,BLK CHROMATE,THREAD FORMING	832246	4
H30-32	SCREW,4-14,,312,PAN,PHILLIPS,STEEL,ZINC-CLEAR,THD FORM,#3 HEAD	642931	3
MP32	FLUKE 87-8004,CONTACT,PTF	822676	1
F1 	FUSE,315 MA,1000 V AC/DC,FAST,6.35 X 32 MM,BULK	2279339	1
MP44	FLUKE-165X-8008,PROBE,MULTIFUNCTIONAL	2000757	1
MP34	CONNECTOR,ELASTOMERIC,.01IN CTR,.218 IN HIGH,.090 IN THICK,2.43 IN LONG,BULK	2396462	1

Table 12. 1508 Specific Parts

Ref Des	Description	P/N	Qty
MP1	FLUKE-1508-8004-01,CASE TOP,PAD XFER	2282457	1
MP2	FLUKE-1508-8005-03,BRACKET,MASK,PAD XFER	2282504	1
MP3	FLUKE-1508-8018,KEYPAD	2388514	1
MP5	FLUKE-1508-8007-02,DOOR,ACCESS	2388550	1
MP46	FLK 19-8014,TEST LEAD SET	666602	1
MP47	ALLIGATOR CLIP,600/1000V,2MM JACK,RED	1670641	1
MP48	ALLIGATOR CLIP,600/1000V,2MM JACK,BLACK	1670652	1
MP36	1508 USERS MANUAL (Chinese and English)	2416024	1

Table 13. 1507 Specific Parts

Ref Des	Description	P/N	Qty
MP1	FLUKE-1507-8004-01,CASE TOP, PAD XFER	2282433	1
MP2	FLUKE-1507-8005-02,BRACKET,MASK,PAD XFER	2282491	1
MP3	FLUKE-1507-8018-01,KEYPAD	2388523	1
MP5	FLUKE-1507-8007-03,DOOR,ACCESS	2388561	1
MP46	TL224-4201,175-263-011 TEST LEADS RA2S	2070140	1
MP47	021-236-003,ALL.CLIP EX-LARGE RED IEC1010	1958654	1
MP48	021-236-001,ALL. CLIP EX-LARGE BLK IEC1010	1958646	1
MP49	PROBE,TEST,BANANA JACK,4MM TIP,RED W/CAP, 175-290-003	2099044	1
MP50	PROBE,PROBE,TEST,BANANA JACK,4MM TIP,BLACK W/CAP,175-290-001	2427138	1

Table 14. 1503 Specific Parts

Ref Des	Description	P/N	Qty
MP1	FLUKE-1503-8004-01,CASE TOP,PAD XFER	2282416	1
MP2	FLUKE-1503-8005-01,BRACKET,MASK,PAD XFER	2282484	1
MP3	FLUKE-1503-8018-02,KEYPAD	2388538	1
MP5	FLUKE-1503-8007-04,DOOR,ACCESS	2388577	1





205 Westwood Ave
Long Branch, NJ 07740
1-877-742-TEST (8378)
Fax: (732) 222-7088
salesteam@Tequipment.NET