

360

AC Leakage Current Clamp Meter

Calibration Information

Introduction

This document provides the following information for the 360 AC Leakage Current Clamp Meter (hereafter referred to as the Meter or UUT):

- Safety information
- Symbols
- Specifications
- Maintenance
- Performance Tests
- Replacement Parts List
- Product Warranty Statement

For complete operating instructions, refer to the *360 Instruction Sheet*.

Contacting Fluke

To order parts, or for warranty service, contact Fluke as follows:

USA: 1-888-99-FLUKE (1-888-993-5853)

Canada: 1-800-36-FLUKE (1-800-363-5853)

Europe: +31 402-675-200

Japan: +81-3-3434-0181

Singapore: +65-738-5655

Anywhere in the world: +1-425-446-5500

Or, visit Fluke's Web site at www.fluke.com.

To register your product, go to register.fluke.com.

		<p>205 Westwood Ave Long Branch, NJ 07740 1-877-742-TEST (8378) Fax: (732) 222-7088 salesteam@Tequipment.NET</p>
---	---	--

October 2007

© 2007 Fluke Corporation. All rights reserved. Specifications are subject to change without notification. All product names are trademarks of their respective companies.

Safety Information

⚠️⚠️ Safety Information

To avoid electric shock or personal injury, and ensure safe operation and service of the Meter, follow these instructions:

- Read the operating instructions before use and follow all safety instructions.
- Use the Meter only as specified in the operating instructions otherwise the Meter's safety features may be impaired.
- Adhere to local and national safety codes. Individual protective equipment must be used to prevent shock and arc blast injury where hazardous live conductors are exposed.
- Before each use, inspect the Meter. Look for cracks or missing portions of the clamp housing. Also, look for loose or weakened components. Pay particular attention to the insulation surrounding the jaws.
- Disconnect the Meter from measurable conductors under test before opening the case to replace the battery.
- Avoid using the Meter if it has been exposed to rain or moisture or if your hands are wet.
- Do not use the Meter in an atmosphere where flammable or explosive gas is present.
- Do not use the Meter near noise-emitting equipment or where there may be sudden changes in temperature. Otherwise, the Meter may produce unstable readings or errors.
- Never use the Meter on a circuit with voltages greater than 300 V CAT III.











CAT III equipment is designed to protect against transients in equipment in fixed-equipment installations, such as distribution panels, feeders and short branch circuits, and lighting systems in large buildings.

- Use extreme caution when working around bare conductors or bus bars. Contact with the conductor could result in electric shock.
- Use caution when working with voltages above 60 V dc or 30 V ac. Such voltages pose a shock hazard.
- Do not leave the Meter exposed to direct sunlight or in a hot or humid location for any prolonged period.
- Keep fingers behind the tactile barrier (see Figure 3).

Symbols

Table 1 describes the symbols that appear on the Meter or in this document.

Table 1. Symbols

Symbol	Explanation
	Product is protected by double insulation
	Risk of Danger. Important information.
	Hazardous voltage. Risk of electrical shock.
	AC (Alternating Current)
	DC (Direct Current)
	Earth ground
	Application to or removal from hazardous, live conductors is permitted
	Do not dispose of this product as unsorted municipal waste. Go to Fluke's Web site for recycling information.
	Conforms to requirements of European Union
	Battery

Specifications

General Specifications

Measurement functions	AC current
Additional functions	Data hold and auto power off
Display (LCD)	
Digital reading	3200 counts
Bar graph	32 segments
"OL" over-range indication	
Low-battery symbol	
Range selection	Automatic
Sampling	
Digital reading	2 times per second
Bar graph	12 times per second
Operating temperature and humidity range	0 °C to 50 °C (32 °F to 122 °F) with a maximum humidity of 80 % RH (no condensation)
Storage temperature and humidity range	-20 °C to 60 °C (-4 °F to 140 °F) with humidity range 20 to 70 % RH (no condensation)
Temperature coefficient	± 0.05 % of measuring range / °C (< 18 °C or > 28 °C)
Measuring range	0 to 50 A
Effect of external magnetic fields	0.0005 % typical value (in terms of the magnitude of current in adjacent wires)
Maximum conductor size	40 mm (1.6 in)
Maximum circuit voltage	300 V rms
Power consumption	6 mW maximum
Automatic power off	Automatically turns off the power approximately 10 minutes after the last switch operation. The beeper will turn on 15 seconds before power off.
Power supply	CR2032 lithium battery
Battery life	Approximately 90 hours of continuous operation

Dimensions (W x H x D)..... 70 mm x 176 mm x 25 mm (2.8 in x 6.9 in x 1.0 in)
Weight (including battery)..... Approximately 200 g (0.44 lb)

Safety Specifications

Category rating..... CAT III 300 V per IEC/EN61010-1, and 61010-2-032 Pollution Degree 2, indoor use
EMC..... EN61326-1
Effect of radiated immunity..... Rated accuracy + 4.0 % in an electromagnetic field of 3 v/m
Operating altitude..... 2,000 m (6,562 ft)
Accessories..... C75 soft carrying case

Electrical Specifications

Reference conditions 23 ± 5 °C and 80 % RH maximum

AC Current Measurement

Range	Resolution	Accuracy (50/60 Hz) ± (% of reading + digit)	Maximum Allowable Current
3 mA	0.001 mA	1 % + 5	60 A rms
30 mA	0.01 mA		
30 A	0.01 A	0 to 50 A: 1 % + 5	
60 A	0.1 A	50 to 60 A: 5 % + 5	

Zero correction: Fractions smaller than approximately 0.01 mA are calibrated to zero.

Maintenance

Basic maintenance for the Meter includes cleaning, checking the battery charge, and replacing depleted batteries.

Cleaning

Periodically wipe the case with a damp cloth and mild detergent.

Caution

To avoid damage, do not use abrasives or solvents to clean the meter.

Open the jaws and blow air to remove dust or debris at the jaw mating surfaces.

Battery Replacement

If battery voltage drops below the operating voltage, the battery symbol () appears on the display. If this happens, replace the battery as soon as possible.

Warning

To avoid risk of electric shock during battery replacement, always remove the Meter from measurable conductors under test before replacing the battery. Always use the correct replacement battery (see Table 5).

To replace the battery, complete the following steps and refer to Figure 1:

1. Ensure the power is off.
2. Place the Meter on its face and turn the battery cover counterclockwise using a Phillips screwdriver.
3. Remove the cover and the installed battery.
4. Insert the battery ensuring the polarity is correct.
5. Close the battery cover, aligning the arrow's tail with the dot and then turn clockwise.

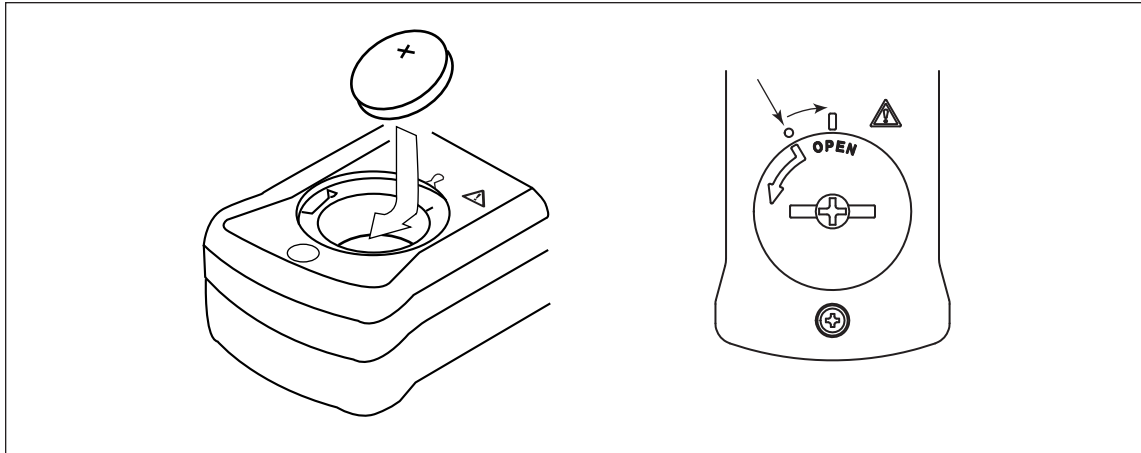

Figure 1. Changing the Battery

epq003.eps

Performance Tests

⚠⚠ Warning

To avoid possible electric shock, do not perform the performance test procedures unless the Meter is fully assembled and you are qualified to do so.

The following performance tests verify the complete operation of the Meter and check the accuracy of each Meter function against its specifications. The recommended calibration interval is 12 months. In the performance tests, the Meter is referred to as the unit under test (UUT). Before you perform any of the following tests, check the battery and replace if necessary. For more information, see *Battery Replacement*. If the UUT fails any performance test, contact Fluke Service for repair. See *Contacting Fluke*.

Required Equipment

Table 2 lists the equipment required to complete the performance tests.

Table 2. Required Equipment

Equipment	Minimum Required Characteristics	Recommended Model
Calibrator	AC current: <ul style="list-style-type: none"> • Accuracy <ul style="list-style-type: none"> ACmA: $\pm 0.25\%$ Amps: 30 A $\pm 0.19\%$ 60 A $\pm 0.49\%$ • Frequency = 50/60 Hz 	Fluke 5520A High Performance Multi-Product Calibrator
Magnet wire coil	3 turns, 14-gauge film-coated copper wire, 6-in. diameter	---
Magnet wire coil	2 turns, 14-gauge film-coated copper wire, 6-in. diameter	---
Copper wire coil	1 turn, 14-gauge copper wire, 6-in. diameter	---

Testing the LCD

Use the following procedure to test the LCD:

1. Press the power button and observe the LCD during the selftest startup mode.
2. Compare the LCD with the example in Figure 2.
3. Check all display segments for clarity and contrast.

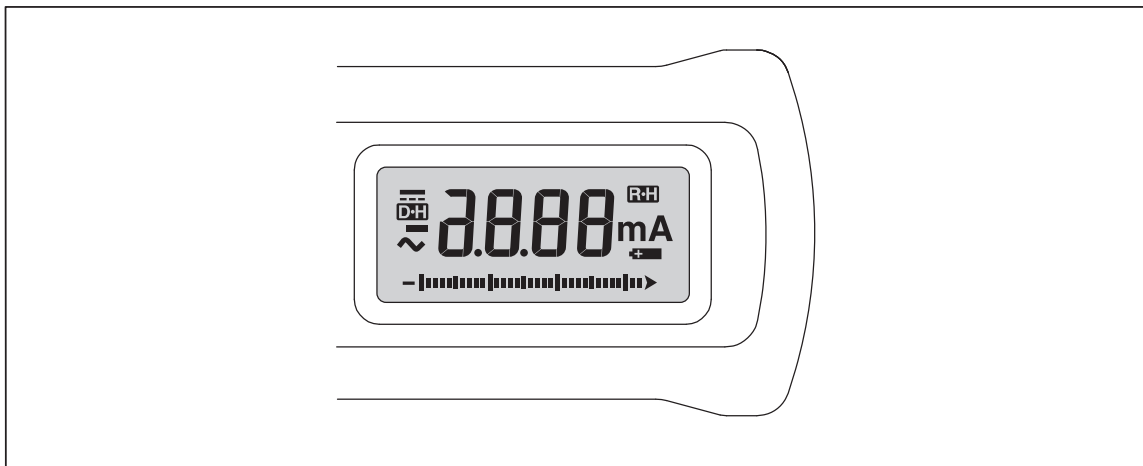

Figure 2. LCD Test

fcx01.eps

Data Hold Test

Use the following procedure to test the Data Hold function:

1. Press the Power button to turn on the UUT.
2. Press the Hold button and verify that the beeper sounds and the **D•H** symbol appears on the display.

Accuracy Tests

Accuracy specifications are valid for one year after calibration when measured at an operating temperature of 18 °C to 28 °C. Allow the UUT to stabilize at room temperature before you perform the accuracy tests.

To verify the accuracy of the UUT functions, complete the following steps:

1. Connect the wire coils, listed in Table 2, across the current output terminals of the calibrator.
2. Set the Calibrator Output for the value listed in Table 3.
3. Clamp the UUT around the wire coil at the output terminals.
4. Compare the UUT displayed reading with the Display Reading Limits in Table 3. If any of the display readings fall outside of these limits, the UUT requires calibration adjustment or repair.

Table 3. 360 Accuracy Tests

Step	Range	Wire Coil	Calibrator Output	Display Reading Limits	
				Low Limit	High Limit
1	3 mA	None	0.000 mA	0.000	0.005
2		1 Turn	0.3 mA, 50 Hz	0.292	0.308
3			3 mA, 50 Hz	2.965	3.035
4			3 mA, 60 Hz	2.965	3.035
5	30 mA		3 mA, 50 Hz	2.92	3.08
6		30 mA, 50 Hz	29.65	30.35	
7	30 A	None	0.00 A	0.00	0.05
8		1 Turn	3 A, 50 Hz	2.92	3.08
9		2 Turns	15 A, 50 Hz	29.65	30.35
10	60 A	3 Turns	16 A, 50 Hz	47.4	48.6
11			20 A, 50 Hz	56.5	63.5

Calibration Adjustment

Before accessing the adjustment locations, remove the face and serial number decals as follows:

1. Use an exacto knife to lift one corner of the face decal from the top case.
2. Peel the entire decal from the case.
3. Use an exacto knife to lift one corner of the serial number decal from the bottom case.
4. Peel the entire decal from the case.

Note

It is possible to reuse the face decal. However, the serial number decal is easily damaged. If either decal needs replacement, see Table 5 and Contacting Fluke.

Refer to Figure 3 for the adjustment locations and complete the adjustments listed in Table 4.

1. Connect the wire coils to the appropriate output current terminals of the Calibrator. See Table 4.
2. Set the Calibrator Output.
3. Clamp the UUT around the wire coils.
4. Perform the adjustment for each step listed in Table 4 to obtain display reading within the adjustment limits shown.

If the UUT fails to meet any expected results, contact Fluke Service for repair. See *Contacting Fluke*.

Table 4. Calibration Adjustment Steps

Step	Selected Range	Wire Coils	Calibrator Output	Adjustment	Adjustment Limits
1	30 A	2	13.5, 60 Hz	VR1	26.97 to 27.03
2	mA	None	3 mA, 60 Hz	VR6	2.998 to 3.002
3			20 mA, 50 Hz 20 mA, 60 Hz	VR5	Adjust VR5 for same reading at 50 and 60 Hz
4			0.008 mA, 60 Hz	VR7	0.000 to 0.005 mA
5			0.012 mA, 60 Hz	N/A	0.009 to 0.012 mA

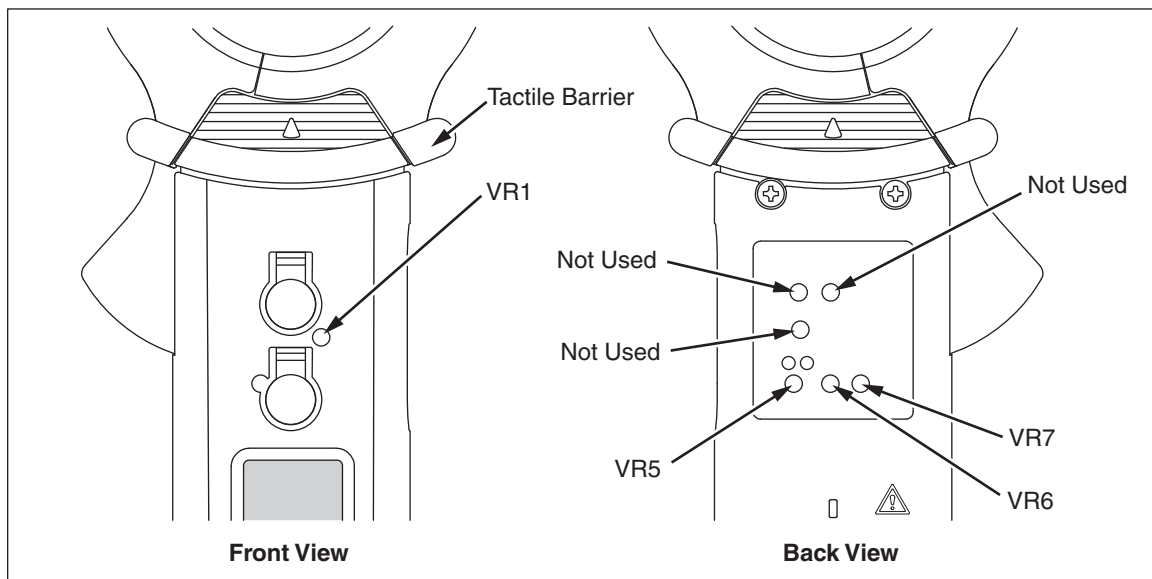

Figure 3. Adjustment Locations

fcx02.eps

The calibration adjustment is complete.

Replacement Parts List

Table 5 lists the replacement parts that are available for the Meter. Figure 4 shows the location of each part. To order replacement parts, see *Contacting Fluke*.

Table 5. Replacement Parts List

Reference	Description	Fluke Part Number	QTY
①	Face Decal	3014486	1
②	Side Decal	3014499	1
③	Serial Number Decal	3014506	1
④	Top Case	3014514	1
⑤	Bottom Case	3014523	1
⑥	Battery Cover	3014538	1
⑦	Lithium Battery, 3.0 V, 0.18 AH	929369	1
⑧	Positive Battery Contact	3033481	1
⑨	Negative Battery Contact	3033496	1
⑩	360 Calibration Instructions	N/A – see www.fluke.com	1

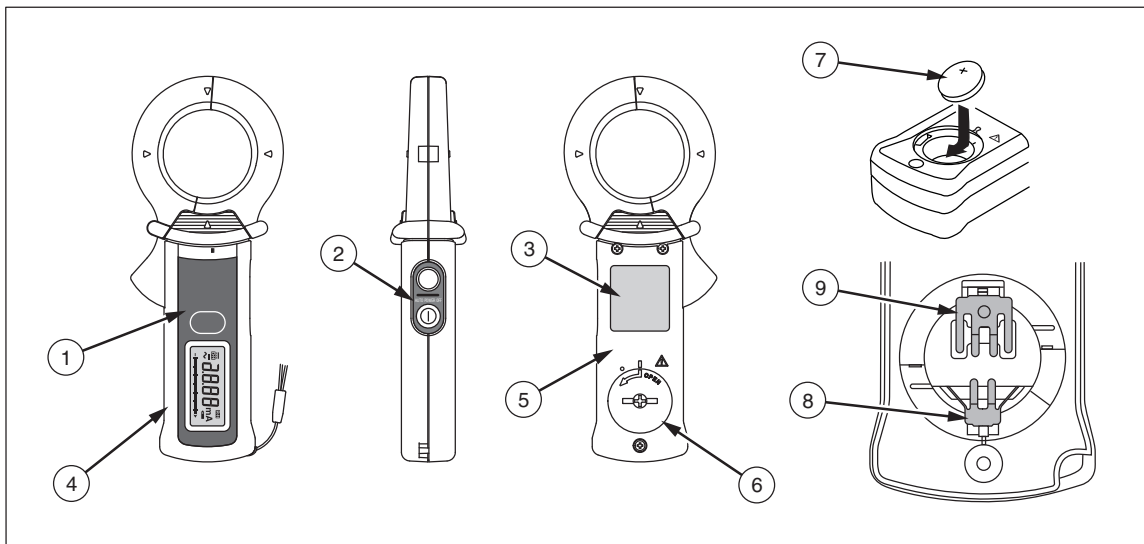

Figure 4. Replacement Parts

fcx03.eps

Limited Warranty and Limitation of Liability

Each Fluke product is warranted to be free from defects in material and workmanship under normal use and service. The warranty period is one year and begins on the date of shipment. Parts, product repairs, and services are warranted for 90 days. This warranty extends only to the original buyer or end-user customer of a Fluke authorized reseller, and does not apply to fuses, disposable batteries, or to any product which, in Fluke's opinion, has been misused, altered, neglected, contaminated, or damaged by accident or abnormal conditions of operation or handling. Fluke warrants that software will operate substantially in accordance with its functional specifications for 90 days and that it has been properly recorded on non-defective media. Fluke does not warrant that software will be error free or operate without interruption.

Fluke authorized resellers shall extend this warranty on new and unused products to end-user customers only but have no authority to extend a greater or different warranty on behalf of Fluke. Warranty support is available only if product is purchased through a Fluke authorized sales outlet or Buyer has paid the applicable international price. Fluke reserves the right to invoice Buyer for importation costs of repair/replacement parts when product purchased in one country is submitted for repair in another country.

Fluke's warranty obligation is limited, at Fluke's option, to refund of the purchase price, free of charge repair, or replacement of a defective product which is returned to a Fluke authorized service center within the warranty period.

To obtain warranty service, contact your nearest Fluke authorized service center to obtain return authorization information, then send the product to that service center, with a description of the difficulty, postage and insurance prepaid (FOB Destination). Fluke assumes no risk for damage in transit. Following warranty repair, the product will be returned to Buyer, transportation prepaid (FOB Destination). If Fluke determines that failure was caused by neglect, misuse, contamination, alteration, accident, or abnormal condition of operation or handling, including overvoltage failures caused by use outside the product's specified rating, or normal wear and tear of mechanical components, Fluke will provide an estimate of repair costs and obtain authorization before commencing the work. Following repair, the product will be returned to the Buyer transportation prepaid and the Buyer will be billed for the repair and return transportation charges (FOB Shipping Point).

THIS WARRANTY IS BUYER'S SOLE AND EXCLUSIVE REMEDY AND IS IN LIEU OF ALL OTHER WARRANTIES, EXPRESS OR IMPLIED, INCLUDING BUT NOT LIMITED TO ANY IMPLIED WARRANTY OF MERCHANTABILITY OR FITNESS FOR A PARTICULAR PURPOSE. FLUKE SHALL NOT BE LIABLE FOR ANY SPECIAL, INDIRECT, INCIDENTAL, OR CONSEQUENTIAL DAMAGES OR LOSSES, INCLUDING LOSS OF DATA, ARISING FROM ANY CAUSE OR THEORY.

Since some countries or states do not allow limitation of the term of an implied warranty, or exclusion or limitation of incidental or consequential damages, the limitations and exclusions of this warranty may not apply to every buyer. If any provision of this Warranty is held invalid or unenforceable by a court or other decision-maker of competent jurisdiction, such holding will not affect the validity or enforceability of any other provision.

Fluke Corporation
P.O. Box 9090
Everett, WA 98206-9090
U.S.A.

Fluke Europe B.V.
P.O. Box 1186
5602 BD Eindhoven
The Netherlands

11/99

To register your product online, visit register.fluke.com.

		<p>205 Westwood Ave Long Branch, NJ 07740 1-877-742-TEST (8378) Fax: (732) 222-7088 salesteam@Tequipment.NET</p>
---	---	--