



**88**

Automotive Meter

## Service Manual

For IEC 61010 CAT II Meters Only

PN 666856

November 1998 Rev.1, 11/99

© 1998, 1999 Fluke Corporation. All rights reserved. Printed in U.S.A.

All product names are trademarks of their respective companies.

#### **LIMITED WARRANTY & LIMITATION OF LIABILITY**

Fluke Corporation (Fluke) warrants this product to be free from defects in material and workmanship under normal use and service for the life of the product. This warranty extends only to the original buyer or end-user customer of a Fluke authorized reseller, and does not apply to fuses, batteries or to any product which, in Fluke's opinion, has been misused, altered, neglected or damaged by accident or abnormal conditions of operation or handling. Fluke warrants that software will operate on appropriate Fluke instruments substantially in accordance with its functional specifications for 90 days and that it has been properly recorded on non-defective media. Fluke does not warrant that software will be error free or operate without interruption.

Fluke authorized resellers shall extend this warranty on new and unused products to end-user customers only but have no authority to extend a greater or different warranty on behalf of Fluke.

Fluke's warranty obligation is limited, at Fluke's option, to refund of the purchase price, or free of charge repair or replacement of a defective product which is returned to an authorized Fluke Service Center within the warranty period.

To obtain warranty service, contact your nearest Fluke Service Center or send the product, with a description of the difficulty, postage and insurance prepaid (FCA Destination), to the nearest Fluke Service Center. Fluke assumes no risk for damage in transit. Following warranty repair, the product will be returned to Buyer, transportation prepaid (FCA Destination). If Fluke determines that the failure was caused by misuse, alteration, accident or abnormal condition of operation or handling, Fluke will provide an estimate of repair costs and obtain authorization before commencing the work. Following repair, the product will be returned to the Buyer transportation prepaid and the Buyer will be billed for the repair and return transportation charges (FCA Shipping Point).

Warranty service is available outside the United States only if product was purchased through a Fluke Authorized Sales Outlet in the country of use or the applicable Fluke international price was paid. Product transported from the United States for which the applicable Fluke international price was not paid must be returned to the U.S. to receive warranty service, at the shipment expense and risk of Buyer. Fluke reserves the right to invoice Buyer for importation costs of repair/replacement parts when product purchased in one country is submitted for repair in another country.

**THIS WARRANTY IS PURCHASER'S SOLE AND EXCLUSIVE REMEDY AND IS IN LIEU OF ALL OTHER WARRANTIES, EXPRESS OR IMPLIED, INCLUDING BUT NOT LIMITED TO ANY IMPLIED WARRANTY OF MERCHANTABILITY OR FITNESS FOR A PARTICULAR PURPOSE. FLUKE SHALL NOT BE LIABLE FOR ANY SPECIAL, INDIRECT, INCIDENTAL OR CONSEQUENTIAL DAMAGES OR LOSSES, INCLUDING LOSS OF DATA, WHETHER ARISING FROM BREACH OF WARRANTY OR BASED ON CONTRACT, TORT, RELIANCE OR ANY OTHER THEORY.**

Since some countries or states do not allow limitation of the term of an implied warranty, or exclusion or limitation of incidental or consequential damages, the limitations and exclusions of this warranty may not apply to every buyer. If any provision of this Warranty is held invalid or unenforceable by a court of competent jurisdiction, such holding will not affect the validity or enforceability of any other provision of this warranty.

Fluke Corporation  
P.O. Box 9090  
Everett WA  
98206-9090

Fluke Europe B.V.  
P.O. Box 1186  
5602 B.D. Eindhoven  
The Netherlands

## Safety Information

This meter complies with EN 61010-1:1993, ANSI/ISA S82.01-1994 and CAN/CSA C22.2 No. 1010.1-92 Overvoltage Category II. Use the meter only as specified in the Users Manual, otherwise the protection provided by the meter may be impaired.

A **Warning** identifies conditions and actions that pose hazards to the user; a **Caution** identifies conditions and actions that might damage the meter. International electrical symbols used on the meter are shown below.

### Warning

To avoid possible electric shock or personal injury:

- **Do not use the meter if it is damaged. Before use, inspect the case for cracks or missing plastic. Pay particular attention to the insulation surrounding the connectors.**
- **Always turn off power to the circuit before cutting, unsoldering, or breaking the circuit. Small amounts of current can be dangerous.**
- **Inspect the test leads for damaged insulation or exposed metal. Check test lead continuity. Replace damaged leads.**
- **To avoid damage or injury, never use the meter on unprotected circuits that exceed 4800 volt-amps.**
- **Do not use the meter if it operates abnormally. Protection may be impaired. When in doubt, have the meter serviced.**
- **Do not operate the meter around explosive gas, vapor or dust.**
- **Do not apply more than 300 V dc or ac rms (sine) between terminals or between any terminal and earth ground.**
- **Before each use, verify the meter's operation by measuring a known voltage.**
- **When servicing the meter, use only specified replacement parts.**
- **Use caution when working above 30 V ac rms, 42 V ac peak, or 60 V dc. Such voltages pose a shock hazard.**
- **Keep your fingers behind the finger guards on the probe when making measurements.**
- **Connect the common test lead before connecting the live test lead. Disconnect the live test lead first.**
- **Remove test leads from the meter before opening the case.**
- **Use only a single 9 V battery, properly installed in the meter case, to power the meter.**
- **Follow all equipment safety procedures.**
- **Before measuring current, check the meter's fuses (see "How to Test the Fuse").**





- Never touch the probe to a voltage source when the test leads are plugged into the 10 A input jack.
- Always use clamp-on probes (dc current clamps) when measuring current exceeding 10 A.
- DO NOT connect thermocouple to voltages exceeding 30 V.
- Always use a high voltage probe to measure voltage if peak voltage might exceed 300 V.
- To avoid false readings, which could lead to possible electric shock or personal injury, replace the meter's battery as soon as the low battery indicator () appears.
- To avoid fire hazard, only use a fuse identical in type, voltage rating, and current rating to that specified on the fuse rating label located on the case bottom.
- Do not operate the meter if it is disassembled. Always operate the meter with the case top and bottom properly assembled. Disassembly procedures and warnings are in the 78 Automotive Service Manual. Service procedures are for qualified personnel only.

#### Caution

To avoid possible damage to the meter or to equipment under test:

- Disconnect the power to the circuit under test and discharge all high voltage capacitors before testing resistance, continuity or diodes.
- Use the proper function and range for your measurement applications.
- When measuring current, turn off circuit power before connecting the meter in the circuit. Remember to place the meter in series with the current.

#### Symbols

Symbol	Meaning
	Important information. See manual.
	Ground
	Fuse
	Double insulation (Protection Class II)
	Conforms to European Union directives

# Table of Contents

Chapter	Title	Page
<b>1</b>	<b>Introduction and Specifications.....</b>	<b>1-1</b>
1-1.	Introduction .....	1-3
1-2.	Organization of the Service Manual.....	1-3
1-3.	Conventions.....	1-4
1-4.	Specifications .....	1-4
<b>2</b>	<b>Theory of Operation.....</b>	<b>2-1</b>
2-1.	Introduction .....	2-3
2-2.	Functional Block Description.....	2-3
2-3.	Detailed Circuit Description .....	2-5
2-4.	Input Overload Protection .....	2-5
2-5.	Rotary Switch.....	2-5
2-6.	Input Signal Conditioning Circuits .....	2-5
2-7.	Volts.....	2-6
2-8.	Ohms.....	2-6
2-9.	Analog Section of Integrated Meter IC (U4) .....	2-6
2-10.	Microcomputer Control .....	2-8
2-11.	Peripherals to U4.....	2-9
2-12.	AC Buffer .....	2-10
2-13.	AC Converter.....	2-10
2-14.	Active Filter .....	2-10
2-15.	A/D Converter .....	2-10
2-16.	Beeper .....	2-10
2-17.	Reference Voltage .....	2-10
2-18.	Power Supply.....	2-10
2-19.	Display .....	2-11
2-20.	Rotary Knob Switch and Potentiometer .....	2-11
<b>3</b>	<b>Maintenance .....</b>	<b>3-1</b>
3-1.	Introduction .....	3-3
3-2.	Required Tools and Equipment.....	3-3
3-3.	Operator Maintenance .....	3-4
3-4.	Disassembling the Case.....	3-5
3-5.	Removing and Reinstalling the Circuit Assembly.....	3-5

3-6.	Reassembling the Case.....	3-6
3-7.	Replacing the Battery.....	3-7
3-8.	Testing Fuses .....	3-7
3-9.	Replacing Fuses .....	3-7
3-10.	Cleaning .....	3-8
3-11.	Input Terminals.....	3-8
3-12.	Function Encoding Potentiometer .....	3-8
3-13.	Performance Test.....	3-9
3-14.	Testing the Display .....	3-9
3-15.	Testing Function Selection (Rotary Switch).....	3-10
3-16.	Testing the AC Voltage Function .....	3-10
3-17.	Testing the Frequency Counter Function.....	3-11
3-18.	Testing Frequency Sensitivity and Trigger Level.....	3-12
3-19.	Testing the DC Voltage Function .....	3-12
3-20.	Testing the DC mV Function.....	3-13
3-21.	Testing the Ohms Function .....	3-13
3-22.	Testing the Diode Test Function.....	3-13
3-23.	Testing the mA Functions .....	3-13
3-24.	Testing the Amp Functions .....	3-14
3-25.	Testing the Inductive Pickup.....	3-14
3-26.	Calibration.....	3-18
3-27.	Troubleshooting the Power Supply .....	3-19
3-28.	Common (Shunt) Regulator Troubleshooting.....	3-21
3-29.	VDD (Series) Regulator Troubleshooting .....	3-23
3-30.	Troubleshooting a Function Selection Malfunction.....	3-23
3-31.	Meter Does Not Turn Off (Problem 1) .....	3-24
3-32.	Meter Enters Wrong Function (Problem 2) .....	3-24
<b>4</b>	<b>List of Replaceable Parts .....</b>	<b>4-1</b>
4-1.	Introduction .....	4-3
4-2.	How to Obtain Parts .....	4-3
4-3.	Manual Status Information.....	4-3
4-4.	Newer Instruments.....	4-4
4-5.	Service Centers.....	4-4
4-6.	Parts Lists .....	4-4
<b>5</b>	<b>Schematic Diagrams.....</b>	<b>5-1</b>

# **List of Tables**

<b>Table</b>	<b>Title</b>	<b>Page</b>
1-1.	Summary of Accuracy Specifications.....	1-5
2-1.	Typical Voltage Levels and Tolerance.....	2-11
3-1.	Required Equipment .....	3-3
3-2.	Function Selection Test .....	3-10
3-3.	AC Voltage Test .....	3-11
3-4.	Frequency Test.....	3-11
3-5.	Frequency Counter Sensitivity and Trigger Level Tests .....	3-12
3-6.	DC Voltage Test .....	3-12
3-7.	Ohms Test .....	3-13
3-8.	Milliamp Tests .....	3-14
3-9.	Amp Tests .....	3-14
3-10.	Functional Description of Power Supply Components .....	3-20
3-11.	Voltage Levels .....	3-20
4-1.	Fluke 88 Final Assembly .....	4-5
4-2.	A1 Main PCA .....	4-7





# *List of Figures*

<b>Figure</b>	<b>Title</b>	<b>Page</b>
2-1.	Overall Functional Block Diagram.....	2-4
2-2.	A/D Conversion .....	2-8
2-3.	Function-Encoding Switch .....	2-12
3-1.	Battery and Fuse Replacement .....	3-4
3-2.	Assembly Details .....	3-6
3-3.	Display Test .....	3-9
3-4.	Setup for Inductive Pickup Test .....	3-16
3-5.	Waveform for Inductive Pickup Test.....	3-17
3-6.	Calibration Adjustment Points.....	3-19
3-7.	Simplified Power Supply Schematic .....	3-22
4-1.	Fluke 88 Final Assembly .....	4-6
4-2.	A1 Main PCA .....	4-9
5-1.	A1 Main PCA .....	5-3

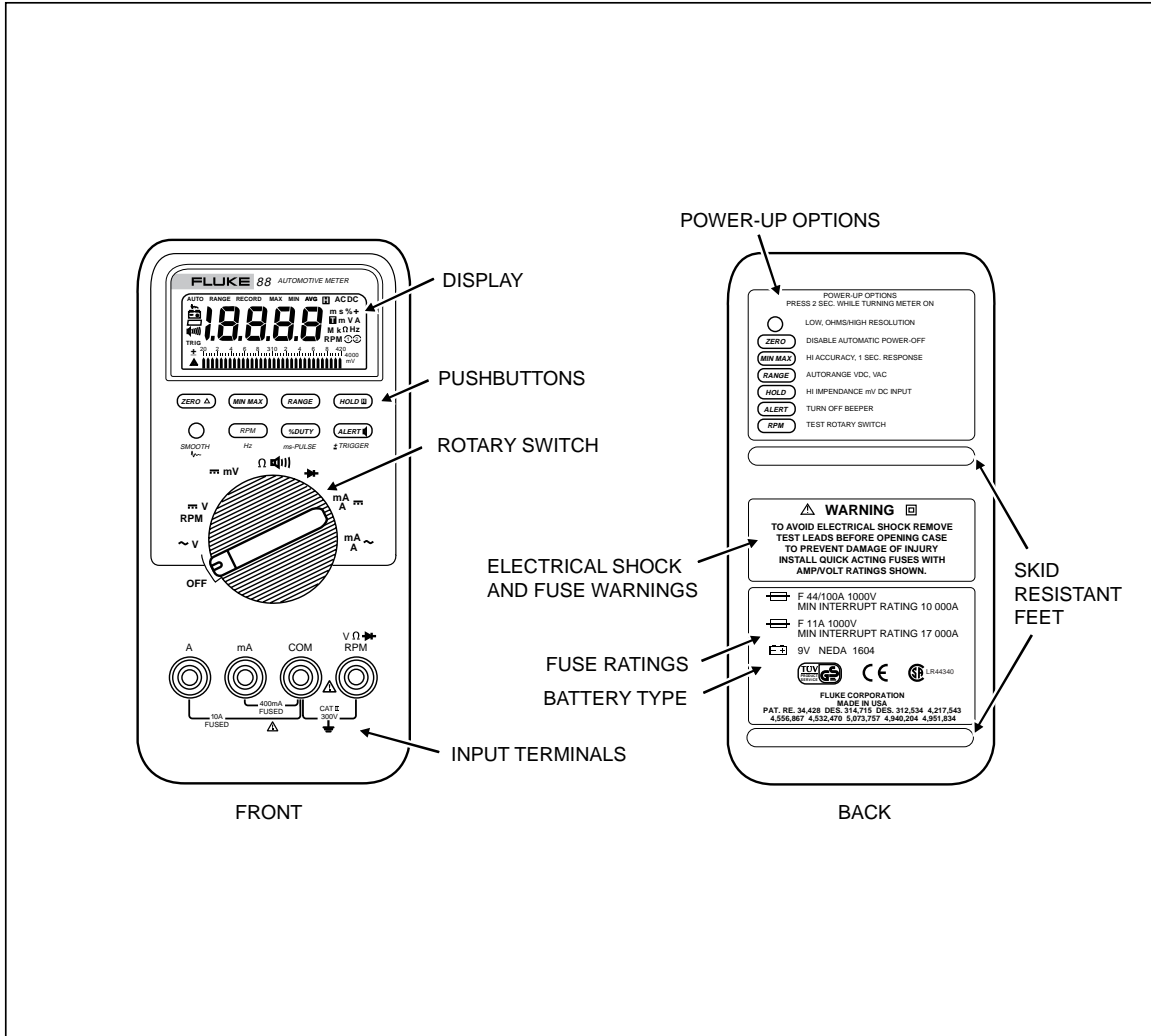

aad01f.eps

Frontispiece

# **Chapter 1**

## ***Introduction and Specifications***

	<b>Title</b>	<b>Page</b>
1-1.	Introduction .....	1-3
1-2.	Organization of the Service Manual.....	1-3
1-3.	Conventions .....	1-4
1-4.	Specifications .....	1-4



## **1-1. Introduction**

This Service Manual provides information necessary to service the Fluke 88 Automotive Meter. This information includes the following:

- Specifications
- Theory of operation
- Calibration routines
- Performance testing and troubleshooting procedures
- Replacement parts lists
- Schematic diagrams

A meter under warranty will be promptly repaired or replaced (at Fluke's option) and returned at no charge. See the registration card for warranty terms. If the warranty has lapsed, the meter will be repaired and returned for a fixed fee. Contact the nearest Service Center for information and prices. To contact Fluke, call one of the following telephone numbers:

USA: 1-888-99-FLUKE (1-888-993-5853)

Canada: 1-800-36-FLUKE (1-800-363-5853)

Europe: +31 402-678-200

Japan: +81-3-3434-0181

Singapore: +65-738-5655

Anywhere in the world: +1-425-446-5500

Or, visit Fluke's Web site at [www.fluke.com](http://www.fluke.com).

## **1-2. Organization of the Service Manual**

The Service Manual has five chapters.

### **Chapter 1. Introduction and Specifications**

Chapter 1 describes the Service Manual and explains conventions used to describe the meter's circuitry. A complete set of specifications appears at the end of this chapter.

### **Chapter 2. Theory of Operation**

Chapter 2 treats the meter's circuitry as functional blocks, with a description of each block's role in overall operation. A detailed circuit description is then given for each block. These descriptions explore operation to the component level and support the troubleshooting and repair procedures in Chapter 3.

### **Chapter 3. Maintenance**

Chapter 3 provides complete maintenance information, detailed troubleshooting and repair procedures to the component level, and performance tests. Troubleshooting and repair procedures rely on the theory of operation in Chapter 2 and the schematic diagrams in Chapter 5.

### **Chapter 4. List of Replaceable Parts**

Chapter 4 provides parts lists for all assemblies and information on how to order parts.

## Chapter 5. Schematic Diagrams

Chapter 5 provides the schematic diagrams. A list of mnemonic definitions is included to aid in identifying signal name abbreviations.

### 1-3. Conventions

The following conventions are used in this manual:

- Instrument Reference  
The term "Meter" is used when discussing the Fluke 88 Automotive Meter.
- Printed Circuit Assembly  
The term "pca" is used to mean a printed circuit board and its attached parts.
- Signal Logic Polarity  
Signal names followed by a minus sign (-) are active (or asserted) low. Signals not so marked are active high.
- Circuit Nodes  
Individual pins or connections on a component are specified by a dash (-) following the component reference designator. For example, pin 19 of U30 would be U30-19.
- User Notation  
Pushbuttons, positions on the rotary switch, input terminals, and the display are generally shown in the manual as they appear on the Meter. Mnemonics used in the text that describe Meter circuitry are the same as those used on the schematic diagrams in Chapter 5.

### 1-4. Specifications

Specifications for the Fluke 88 follow.

Accuracy is specified at 18°C to 28°C (64°F to 82°F) with relative humidity up to 90%, for a period of one year after calibration. AC Conversions are ac-coupled, average responding, and calibrated to the RMS value of a sine wave input.

#### *Note*

*The Fluke 88 has a Lo-Ohms/High Resolution power-up option. In the Lo-Ohms/High Resolution mode, the resolution is ten times that in the following specifications. To enter the Lo-Ohms/High Resolution mode, press and hold down the SMOOTH button, while turning the rotary switch to a function setting.*

Table 1-1 provides a summary of the accuracy specifications for basic meter functions. The complete Meter specifications follow Table 1-1. In the complete specifications, accuracy is given as:  $\pm$ ([% of Reading] + [Number of Least Significant Digits])

**Table 1-1. Summary of Accuracy Specifications**

Function	Basic Accuracy ( $\pm$ % of Reading)
Volts AC $\sim$ V	1.5%
Volts DC $\equiv$ V	0.15%
Resistance $\Omega$	0.2%
Milliamps/Amps DC mA A $\equiv$	0.8%
Frequency Hz	0.01%

**Input Terminal Limits**

Rotary Switch Function	Red Lead	Min Display Reading	Max Display Reading	Maximum Input **
$\sim$ V	V $\Omega$ $\rightarrow$	0.01 mV	1000 V	300 V
$\equiv$ V RPM	RPM	0.0001 V	1000 V	300 V
$\equiv$ mV	V $\Omega$ $\rightarrow$	0.01 mV	400.0 mV	300 V
$\parallel$ $\Omega$	V $\Omega$ $\rightarrow$	0.01 $\Omega$ (Lo-Ohms)	400.0 M $\Omega$	300 V
$\rightarrow$	V $\Omega$ $\rightarrow$	0.0001V	3.000 V	300 V
mA A $\sim$	A mA	0.1 mA 0.001 mA	20.00 A** 400.0 mA	10 A/300 V* 400 mA/300 V
mA A $\equiv$	A mA	0.1 mA 0.001	20.00 A** 400.0 mA	10A/300 V* 400 mA/300 V

\* 10A continuous, 20A overload for 30 seconds maximum.

\*\*  $10^7$  V-Hz maximum.

**Volts AC**

Range	Resolution	Accuracy *	
		45 Hz to 1 kHz	1 kHz to 5 kHz
400.0 mV	0.1 mV	$\pm(1.5\%+10)$	$\pm(1.9\%+10)$
4.000 V	0.001 V	$\pm(1.5\%+5)$	$\pm(1.9\%+5)$
40.00 V	0.01 V	$\pm(1.5\%+5)$	$\pm(1.9\%+5)$
300.0 V	0.1 V	$\pm(1.5\%+5)$	$\pm(1.9\%+5)$
300 V	1 V	$\pm(2.5\%+5)$	$\pm(2.5\%+5)$

\*Below a reading of 200 counts, add 10 digits.

**Volts DC**

Range	Resolution	Accuracy
4.000 V	0.001 V	$\pm(0.15\%+2)$
40.00 V	0.01 V	$\pm(0.15\%+2)$
300.0 V	0.1 V	$\pm(0.15\%+2)$
300 V	1 V	$\pm(0.3\%+2)$

**Millivolts DC**

Range	Resolution	Accuracy
400.0 mV	0.1 mV	$\pm(0.15\%+2)$

**Resistance**

Range	Resolution	Accuracy
400.0 $\Omega$	0.1 $\Omega$ *	$\pm(0.2\%+2)$
4.000 k $\Omega$	0.001 k $\Omega$	$\pm(0.2\%+2)$
40.00 k $\Omega$	0.01 k $\Omega$	$\pm(0.2\%+2)$
400.0 k $\Omega$	0.1 k $\Omega$	$\pm(0.2\%+2)$
4.000 M $\Omega$	0.001 M $\Omega$	$\pm(0.2\%+2)$
40.00 M $\Omega$	0.01 M $\Omega$	$\pm(1\%+3)$
400.0 M $\Omega$ **	0.1 M $\Omega$	$\pm(1\%+20)$

\* In Lo-Ohms/High Resolution Mode, increases to 0.01 $\Omega$ .

\*\*This range will not be entered by Autorange. It must be selected manually.

**Diode Test**

Range	Resolution	Accuracy
3.000 V	0.001 V	$\pm(2\%+2)$

**mA/A DC**

Range	Resolution	Accuracy	Burden Voltage (typical)
40.00 mA	0.01 mA	$\pm(0.8\%+2)$	2.3 mV/mA
400.0 mA	0.1 mA	$\pm(0.8\%+2)$	2.3 mV/mA
4000 mA	1 mA	$\pm(0.8\%+2)$	0.03 V/A
10.00 A*	0.01A	$\pm(1.3\%+2)$	0.03 V/A

\* 10A continuous, 20A overload for 30 seconds maximum.



**mA/A AC (45 Hz to 2 kHz)**

Range	Resolution	Accuracy **	Burden Voltage (typical)
40.00 mA	0.01 mA	±(3%+10)	2.3 mV/mA
400.0 mA	0.1 mA	±(3%+5)	2.3 mV/mA
4000 mA	1 mA	±(1.5%+5)	0.03 V/A
10.0 A*	0.01 A	±(1.5%+5)	0.03 VA

\* 10 A continuous, 20 A overload for 30 seconds maximum.

\*\* Below reading of 200 counts, add 10 digits.

**Frequency, RPM, Duty Cycle, and Pulse Width**

Function	Range	Resolution	Accuracy	Pulse Width Range (ms)*	Resolution (ms)
Frequency** (0.5 Hz to 200 kHz,	199.99	0.01 Hz	±(0.01%+1)	1999.9	0.1
	1999.9	0.1 Hz	±(0.01%+1)	5.00	0.01
	19.999 kHz	0.001 kHz	±(0.01%+1)	0.500	0.001
Pulse Width >2 μs)	199.99 kHz	0.01 kHz	±(0.01%+1)	0.0500	0.0001
	>200 kHz	0.1 kHz	Unspecified		
RPM 1	30-9,000	1 RPM	± 2 RPM		
RPM 2	60-12,000	1 RPM	± 2 RPM		
% Duty Cycle***	0.0-99.9% (0.5 Hz to 200 kHz, Pulse Width > 2 μs)				
Pulse Width ***	0.002-1999.9 ms (4 Hz to 200 kHz, Pulse Width > 2 μs)				

\* Pulse Width range is determined by the frequency of the signal.

\*\* Frequency measurements can be made on voltage or current inputs. The current inputs are always dc-coupled.

\*\*\* For rise times < 1 μs. Duty Cycle accuracy: within ±(0.2% per kHz + 0.1%). Pulse Width accuracy: ±(00.002 ms + 3 digits).

**Counter Sensitivity and Trigger Level**

Input Range*	Minimum Sensitivity @ 0.5 Hz-200 kHz (RMS Sinewave)	Approximate Trigger Level (DC Voltage Function)
400.0 mV dc	70 mV (to 400 Hz)	40 mV
400.0 mV ac	150 mV	-
4.000 V	0.7 V	1.7 V
40.00 V	7 V	4 V
300.0 V	70 V (≤140 kHz)	40 V

Maximum input for specified accuracy = 10 × Range or 300 V.

## Common and Normal Mode Rejection Ratio

Function	Overload Protection*	Input Impedance (nominal)	Common Mode Rejection Ratio (1 k $\Omega$ unbalance)	Normal Mode Rejection Ratio	
$\overline{=}$ V	300 V rms	10 M $\Omega$ , <100 pF	>120 dB at dc, 50 Hz, or 60 Hz	>60 dB at 50 Hz or 60 Hz	
$\overline{=}$ mV	300 V rms	10 M $\Omega$ , <100 pF	>120 dB at dc, 50 Hz, or 60 Hz	>60dB at 50 Hz or 60 Hz	
$\sim$ V	300 V rms	10 M $\Omega$ , <100 pF (ac-coupled)	>60 dB, dc to 60 Hz		
		<b>Open Circuit Test Voltage</b>	<b>Full Scale Voltage</b>		<b>Short Circuit Current</b>
			<b>To 4.0 m<math>\Omega</math></b>	<b>40 M<math>\Omega</math> or nS</b>	
$\Omega$	300 V rms	<1.3 V dc	<450 mV dc	<1.3V dc	<500 $\mu$ A
Diode Test	300V rms	<3.9 V dc	3.000 V dc		1.0 mA typical

\*  $10^7$  V-Hz max.

## MIN MAX Recording

Nominal Response	Accuracy
100 ms to 80%	Specified accuracy $\pm$ 12 digits for changes > 200 ms in duration
1 sec	Same as specified accuracy for changes > 2 seconds in duration

**General**

Maximum Voltage between any Terminal and Earth Ground	300 V
Fuse Protection	
mA	1 A 600 V FAST FUSE
A	15 A 600 V FAST FUSE
Display (LCD)	
Digital	Counts: 4,000 19,999 in High Resolution, 4½ -digit Mode only. Update Rate: 1/sec in High Resolution, 4½ -digit mode only. 3/sec in RPM, Frequency, % Duty Cycle, and Pulse Width 4/sec in all other functions and ranges.
Analog	2 x 32 Segments Updates Rate: 40/sec
Frequency and RPM	Counts: 19,999 Update Rate: 3/sec @ > 10 Hz
Backlight	Backlight turns on for 68 seconds, then turns off automatically if not turned off by user.
Meter Operating Temperature	-20°C to 55°C (-4°F to 131°F)
Meter Storage Temperature	-40°C to 60°C (-40°F to 140 °F)
Temperature Coefficient	0.05 x (Specified Accuracy)/ °C (<18°C or >28°C or 64°F or 82°F)
Relative Humidity	0% to 90% (0°C to 35°C; 32°F to 95°F)
	0% to 70% (35°C to 55°C; 95°F to 131°F)
Altitude	2000 meters maximum

Inductive Pickup	
Input	Magnetic Field from Spark Plug
Output	Pulse to Trigger
Maximum RPM	12,000 (RPM 2)
Battery Type	9 V, NEDA 1604 or 6F22 or 006P
Battery Life	500 hrs typical with alkaline
Shock,	PER MIL-T-28800 for a Class 2 instrument.
Vibration	
Size (HxWxL)	
Meter only	1.25 in x 3.41 in x 7.35 in (3.1 cm 8.6 cm x 18.6)
With Holster & Flex- Stand	2.06 in x 3.86 in x 7.93 in (5.2 cm x 9.8 cm x 20.1 cm)
Weight	
Meter only	12.5 oz (355 g)
With Holster & Flex- Stand	22.0 oz (624 g)
Safety	
Meter	Complies with EN61010-1:1993, ANSI/ISA S82.01-1994, CAN/CSA 22.2 No. 1010.1:1992 Overvoltage Category II. UL License, TUV License, CSA License.
Pickup	Specified for spark-plug wire use only.



## **Chapter 2**

# **Theory of Operation**

	<b>Title</b>	<b>Page</b>
2-1.	Introduction .....	2-3
2-2.	Functional Block Description.....	2-3
2-3.	Detailed Circuit Description .....	2-5
2-4.	Input Overload Protection .....	2-5
2-5.	Rotary Switch.....	2-5
2-6.	Input Signal Conditioning Circuits .....	2-5
2-7.	Volts.....	2-6
2-8.	Ohms .....	2-6
2-9.	Analog Section of Integrated Meter IC (U4) .....	2-6
2-10.	Microcomputer Control .....	2-8
2-11.	Peripherals to U4.....	2-9
2-12.	AC Buffer .....	2-10
2-13.	AC Converter.....	2-10
2-14.	Active Filter .....	2-10
2-15.	A/D Converter .....	2-10
2-16.	Beeper .....	2-10
2-17.	Reference Voltage .....	2-10
2-18.	Power Supply.....	2-10
2-19.	Display .....	2-11
2-20.	Rotary Knob Switch and Potentiometer .....	2-11



## **2-1. Introduction**

Chapter 2 provides the theory of operation for the Fluke 88.

An overview of circuit operation is presented in the form of functional block descriptions. Detailed circuit descriptions cover the major circuit functions in more detail. Schematic diagrams are in Chapter 5.

## **2-2. Functional Block Description**

Figure 2-1 is a block diagram of the Fluke 88 Automotive Meter. The Meter is partitioned into analog and digital sections. The integrated meter chip (U4) performs both analog and digital functions.

The analog section of U4 contains the analog-to-digital (a/d) converter, active filter, ac converter, frequency comparator, analog signal routing, range switching, and power supply functions.

The digital logic portion of U4 provides the state machine for synchronous a/d converter control and the 16-bit counter used for a/d converter counts and frequency measurements. Also, the digital logic section contains bus and interrupt control circuits (to facilitate the microcomputer interface) and registers for analog switch drive.

The microcomputer section of U4 executes software functions, formats data for the display, drives the display, and controls most analog and digital logic functions. The pushbuttons initiate various operating modes for the microcomputer. Output from the microcomputer can be presented visually on the liquid crystal display (LCD) and audibly by the beeper.

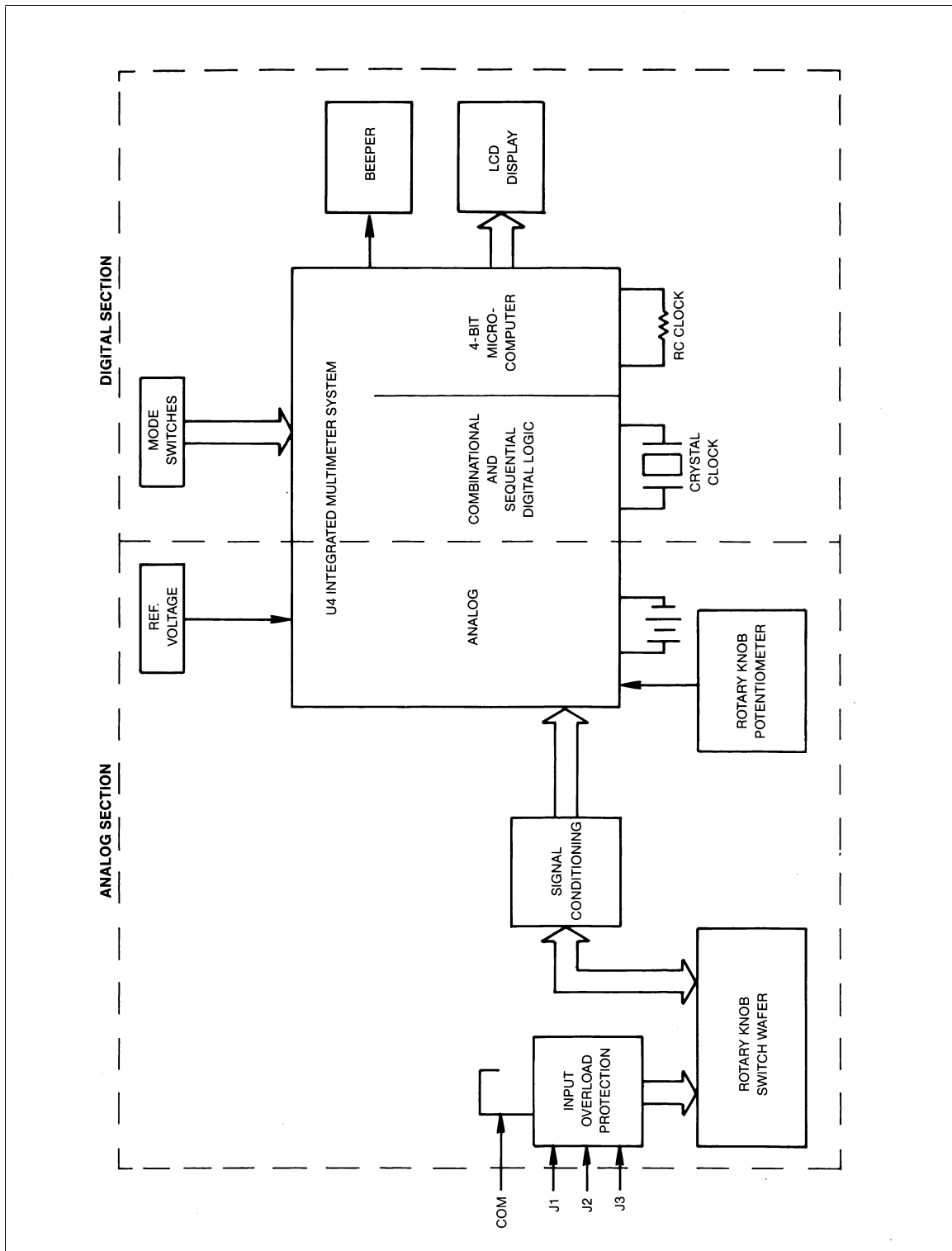

aad02f.tif

Figure 2-1. Overall Functional Block Diagram



### 2-3. Detailed Circuit Description

Each of the functional blocks in Figure 2-1 is discussed in greater detail in the following paragraphs. Refer to the schematic diagrams in Section 5 for details not shown in the figures in this section.

#### 2-4. Input Overload Protection

Overload protection for the  $V\Omega\rightarrow$  input is provided by a network of two metal-oxide varistors (RV1 and RV2), three current-limiting resistors (R1, R2, and RT1), and spark gap E1. The 1-k $\Omega$ , 2W fusible resistor R1 opens when an extremely high energy signal is present. Thermistor RT1 rises to a high impedance during a sustained voltage overload in the mV dc, ohms, or diode test functions. A voltage clamp network is formed by transistors Q1, Q2, and Q6, diodes CR7 and CR8, and resistor R58. During ohms and diode test overloads, this clamp circuit limits the overload current to U4 to 10 mA.

Power supply regulation and system operation is maintained during any of these overloads.

Overload protection for the mA input is provided by F1, rated at 1A/600V. The A input is protected by F2, rated at 15A/600V. In addition, the microamp shunt resistors (R4 and R43) are protected from overload currents below the

F1 fusing level by the U1 and CR1 diode network.

The Input Alert feature provides a beeper warning signal when an input jack is connected to a current input (mA or A) and the rotary switch is not set to a current function (mA or A). The Meter detects the presence of an input connection by using split jacks at the mA and A inputs. One side of the jack is connected to an overload protection resistor (R7 for mA, R10 for A). R7 and R10 are connected to U4 sense lines AP4 and AP5 (pins 89 and 88).

Resistors R8 and R48 provide VDD pull up for AP4, and R11 is the pull up resistor for AP5. When a connection is made at mA or A, the sense side of the jack is pulled to COM. This condition is detected and compared with the selected function by U4. If a conflict exists, the beeper warning is activated.

#### 2-5. Rotary Switch

Input signals are routed from the overload protection circuits to a double-sided switch wafer, which provides the necessary switching to implement the various signal conditioning.

#### 2-6. Input Signal Conditioning Circuits

Each input signal is routed through signal conditioning circuitry before reaching U4. Input signals received through the  $V\Omega\rightarrow$  input are routed through Z1, a precision resistor network. This input divider network provides precise input scaling for the various voltage ranges and precision reference resistors for the ohms and capacitance functions. The capacitors in parallel with the various resistors in Z1 are used for high frequency compensation.

The input divider is used in two modes: in voltage functions, a series mode is used to provide four divider ratios; in the ohms function, a parallel mode provides five reference resistors. During the following discussion, refer to the schematic and signal flow diagrams in Section 5.

### 2-7. Volts

In voltage functions, signal flow for input divider Z1 begins with the unknown voltage at the  $V\Omega \rightarrow$  input, which is connected to the high end of the 9.996-M $\Omega$  resistor (pin 1 of Z1) through R1 and RT1. In ac volts, C1 is also connected in series. In dc volts, C1 is shorted by S1 (contacts 3 and 4). Internal switches connect the 9.996-M $\Omega$  and 1.1111-M $\Omega$  resistors (pin 2 to pin 3 of Z1). The low end of the 1.1111-M $\Omega$  resistor (pin 7 of Z1) is connected to COM through S1 contacts 1 and 2, producing the divide-by-10 ratio used in the 400 mV ac, 4V ac, and 4V dc ranges.

For the 40V range, internal switches connect a 101.01-k $\Omega$  resistor to provide a divide-by-100 ratio. In the 300.0V range, 10.01 k $\Omega$  is used for a divide-by-1000 ratio. And a 1.0001-k $\Omega$  resistor is used in the 300V range to provide a divide-by-10000 ratio.

The internal switch resistance connecting the 1.1111 M $\Omega$  and 9.996 M $\Omega$  with the other resistors is approximately 4 k $\Omega$ . Since the a/d converter senses the voltage at APV1 of U4 (pin 3 of Z1), the internal switch resistance adds to the 9.996-M $\Omega$  resistor, making for a circuit total of 10 M $\Omega$ .

### 2-8. Ohms

In the 400-ohm range the internal switches connect the 9.996-M $\Omega$  resistor (pin 2 of Z1) to the 1.0001-k $\Omega$  resistor (pin 6 of Z1); contacts 5 and 3 of S1 connect the remaining ends to these resistors, making a reference resistor of 1 k $\Omega$ . Again, the 4-k $\Omega$  internal switch resistance adds to the 9.996 M $\Omega$ .

The source voltage is connected internally at both APV0 and APV4 of U4. The current is routed through the 1.0001-k $\Omega$  and 9.996-M $\Omega$  resistors, into S1 at contacts 3 and 5, out of S1 at contact 4, through R1 and RT1, out the  $V\Omega \rightarrow$  input, through the unknown resistance, and back to COM. The same current flows through the unknown resistance and the reference resistor. The voltage dropped across the unknown resistance is sensed from the  $V\Omega \rightarrow$  input jack through R2 and S1 (contacts 11 and 12) to AP1 of U4.

The a/d converter senses the voltage drop across the 1K reference resistor through the low (AP2 of U4 through R13) and high (APV0 and APV4) points. These two voltages are used by the a/d converter to perform a ratiometric measurement.

For the 4-k $\Omega$  range, the 10.010-k $\Omega$  resistor used in parallel with the 9.996-M $\Omega$  resistor forms a 10-k $\Omega$  reference resistor. In the 40-k $\Omega$  range, 101.01 k $\Omega$  and 9.996 M $\Omega$  form a 100-k $\Omega$  reference resistor. And in the 400-k $\Omega$  range, 1.1111 M $\Omega$  and 9.996 M $\Omega$  provide a 1-M $\Omega$  reference resistor. The 4 M $\Omega$  and 40 M $\Omega$  use only the 9.996-M $\Omega$  resistor.

### 2-9. Analog Section of Integrated Meter IC (U4)

The analog-to-digital converter, autorange switching, frequency comparator, and most of the remaining analog circuitry are contained in the analog section of U4. Peripherals to this U4 analog section include the crystal clock, the system reference voltage, and some filter and amplifier resistors and capacitors.

Analog-to-digital conversion is accomplished within U4 using the dual-rate, dual-slope a/d converter circuit shown in Figure 2-2. For most measurements, the basic a/d conversion cycle lasts 25 ms, for 40 measurements per second. A single conversion at this rate is called a minor cycle sample. Each minor cycle sample is used to provide 40 updates per second for the fast response bar graph display, fast MIN MAX recording, and fast autoranging.

Eight minor cycle samples are necessary to accumulate data for displaying a full-resolution (4000 count full scale) measurement on the digital display. A 40-ms autozero

phase occurs following every eight-sample sequence. Therefore, each digital display update requires 240 ms, approximating 4 updates per second.

Basic a/d conversion elements and waveforms are shown in Figure 2-2. As this figure shows, a residual charge is retained by the integrator capacitor due to the overshoot past the true-zero base line. In the absence of an autozero phase, the residual charge would normally produce a significant error in the sample taken next. However, a digital algorithm eliminates the error and accounts for the residual as it propagates through all eight samples.

Basic timing for the a/d converter is defined as a series of eight integrate read cycles, followed by a 40-ms autozero phase. However, the 40-M $\Omega$ , 400-M $\Omega$ , overload recovery, autoranging, Touch Hold, 100-ms MIN MAX, and rotary switch potentiometer modes all require variations from the basic timing.

A voltage comparator, with microcomputer configurable offsets, is used for both signal detection in counter modes and threshold detection in continuity mode. In counter modes, digital pulses from the voltage comparator are routed to the 16-bit counter.

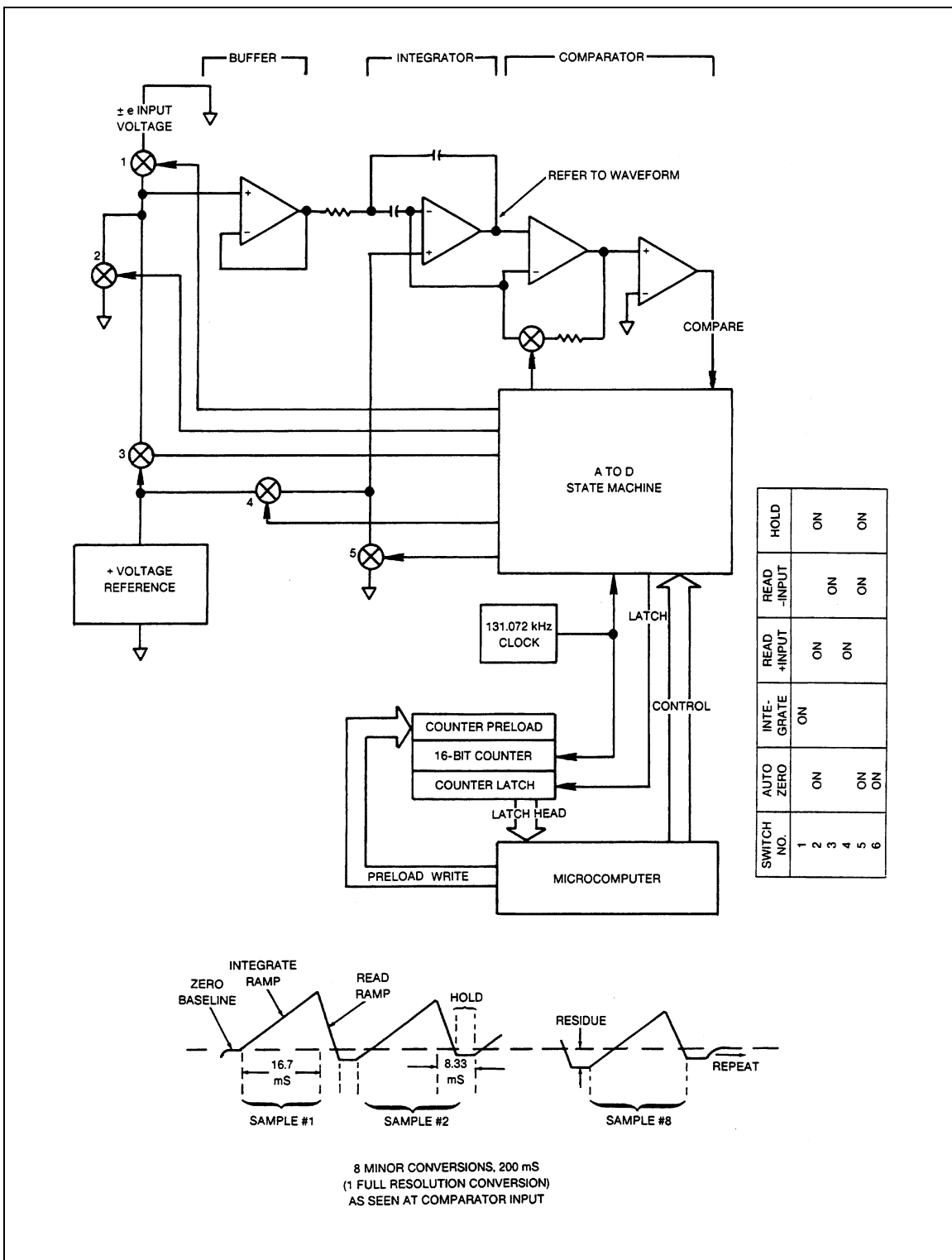

aad03f.wmf

Figure 2-2. A/D Conversion

### 2-10. Microcomputer Control

A 4-bit microcomputer, integrated within U4, controls the various Meter functions and drives the display. A/D converter and counter measurements are controlled via

microcomputer interface lines. The MIN MAX, Touch Hold, and ZERO (relative) modes involve additional data processing by the microcomputer to generate the display value.

Note that the microcomputer runs on its own RC clock at a frequency of 525 to 800 kHz and is asynchronous from the crystal clock.

The microcomputer exercises direct control over the ranging and signal routing analog switches. A specific word is written to the switch drive register for each function/range selection. When the Meter is in autorange, the microcomputer determines the correct range based on the input. In addition, for autoranging during voltage, ohms, or current measurements, the active filter fast mode is enabled for quick response. In the frequency or duty cycle mode, pressing the RANGE button causes a range change in the primary function (volts, amps, etc.) that may change the sensitivity or offset.

The microcomputer sets the required a/d converter mode, which determines the on-chip analog signal ports to be used for the integrate and de-integrate signals. The microcomputer also selects one of the three available gain resistors in Z1 for integrate and de-integrate. All voltage and current conversions use either a 400-mV or a 40-mV full scale mode. Other modes are used for ohms, 4 M $\Omega$ , 40 M $\Omega$ , and 400 M $\Omega$ . Since the a/d state machine timing is under direct software control, a mode invoked in another function or range can use different timing.

Counter measurements are also controlled by the microcomputer section of U4. The microcomputer initializes the counters, monitors the count accumulation, arms and disarms the logic signal gating, and calculates the display value from the counter values.

MIN MAX Recording, Touch Hold, and ZERO (relative) are secondary software functions. This means that the microcomputer performs either a different control algorithm or a different math routine on the data, as explained below.

- In the MIN MAX Recording function, the maximum and minimum readings after initialization are stored in memory, and a true running average is calculated after each reading. The running average is updated for a maximum of 36 hours. The user presses the MIN MAX pushbutton to scroll through the minimum, maximum, average, and present readings. In the 100 ms MIN MAX mode, a single measurement sample is used to calculate the display value; in the 1 second MIN MAX mode, a full resolution conversion is used.
- When the Touch Hold function is selected, the microcomputer does not allow a full resolution conversion to be completed unless the input signal is stable. When a stable reading occurs, the conversion is completed, and the microcomputer generates and freezes the corresponding display. The microcomputer now waits for a change in the signal to exceed a certain threshold, then begins watching for a stable reading again. Note that a reading is forced when Touch Hold is first selected. Also, open test lead signals do not update the display.
- When the ZERO function is selected, the microcomputer stores the present reading as an offset. This value is subtracted from all subsequent readings (provided that they are on scale) to give the display value.

### **2-11. Peripherals to U4**

In addition to input overload protection and input signal conditioning circuits, other devices peripheral to U4 are needed to support Meter features. The ac converter, active filter, and a/d converter circuits require off-chip resistors and capacitors. Digital drive and level-shifting circuits are needed for the beeper drive, quick turn off, and LCD backlight features. A voltage reference is generated separately from U4, and some discrete resistors and transistors support the power supply.

### 2-12. AC Buffer

On the Meter, R14, R15, C5, and C27 are part of the ac buffer circuit that drives the ac converter and guard. The Meter's ac buffer can be configured for an ac gain of 1 or 10.

### 2-13. AC Converter

The Meter's average ac converter uses off-chip components R30, R31, R34, R40, C24, C28, and C29. This ac converter is a full-wave rectifying converter with a differential output and gain selected to give a dc output equal to the rms value for a sine wave input. Filtering is provided by C28 and C29.

### 2-14. Active Filter

The active filter uses off-chip passive components R17, R18, C8, and C9. It is a second order, low pass filter with two poles at 5.9 Hz in normal mode that filters input signal noise and ac ripple from the ac converter, yielding stable a/d converter readings. The microcomputer can disable the filter completely or enable the filter fast response mode.

### 2-15. A/D Converter

Pins 8, 9, and 10 on precision resistor network Z1 connect to the three a/d converter gain resistors. Pin 8 connects to 190 k $\Omega$  for a gain of 0.87. Pin 9 connects to 160 k $\Omega$  for a gain of 1, and pin 10 connects to 16 k $\Omega$  for a gain of 10. Pin 11 is the common connection. The autozero capacitor (C10) stores op amp and comparator offsets. The integration capacitor is C11.

### 2-16. Beeper

Devices Q9, Q11, R56, R57 and CMOS hex inverter U6 make up the double-ended beeper drive circuit. Transistor Q12 is connected to provide quick microcomputer power down when the Meter is turned off.

### 2-17. Reference Voltage

The system reference voltage (1.235V) is generated by VR1 and R44. The 1.000V reference voltage for the a/d converter is supplied through U4-1 (REF1). This voltage is adjusted by R21, the dc calibration potentiometer. In addition to generating the a/d reference, the VR1 voltage is used for power supply reference, voltage comparator selectable offset generation, and the ohms source level.

### 2-18. Power Supply

The power supply consists of two regulators, one shunt and one series, which set VDD at +3.0V and VSS at -3.2V for all battery voltages down to 6.7V. The shunt (common) regulator sets |VDGND - VSS| (VDGND = COM = 0V) and consists of an uncompensated op amp and large current shunt devices integrated on U4. Resistors R37 and R38 provide voltage division. The series (VDD) regulator, which sets |VDD - VDGND|, is made up of another on-chip, uncompensated op amp, along with devices Q3, R24, and R25. Q3 is the series regulator element, and R24 and R25 are for voltage sensing. Capacitors C14 and C21 provide circuit compensation and power supply decoupling for the shunt and series regulators, respectively. Voltage level information is presented in Table 2-1. See Figure 3-7 for a simplified schematic of the power supply.

Table 2-1. Typical Voltage Levels and Tolerance

Signal	Typical Voltage Levels
VDD	3.0 $\pm$ 0.3
VSS	3.2 $\pm$ 0.3
VBT+	3.5 $\pm$ 0.3
VBT-	5.5 (battery at full 9 V charge) 3.0 (battery at low charge of 6.5 V)
REFH	1.235 $\pm$ 0.012
PS0	1.235 $\pm$ 0.015
PS1	0 $\pm$ 0.15
AP6	-0.5 to -0.15
VOA	2.2 to 1.7 (referenced from VSS)
VOB	1.07 to .85 (referenced from VSS)

**2-19. Display**

The liquid-crystal display (LCD) operates under direct control of the microcomputer. Characters are generated by the computer and displayed on the LCD. Both digital readings and the analog pointer are displayed in conjunction with annunciators. The Fluke 88 features a transfective LCD with a light-emitting diode (LED) backlight. Refer to the Fluke 88 Users Manual for a more detailed description of the display.

**2-20. Rotary Knob Switch and Potentiometer**

Input signals are routed from the overload protection circuits to a double-sided switch wafer, which provides the necessary switching to implement the various signal conditioning. The function-encoding potentiometer is attached to the associated rotary switch shaft. After turn on, or a knob position change, U4 performs a voltage ratio measurement on this potentiometer to determine the new function. See Figure 2-3.

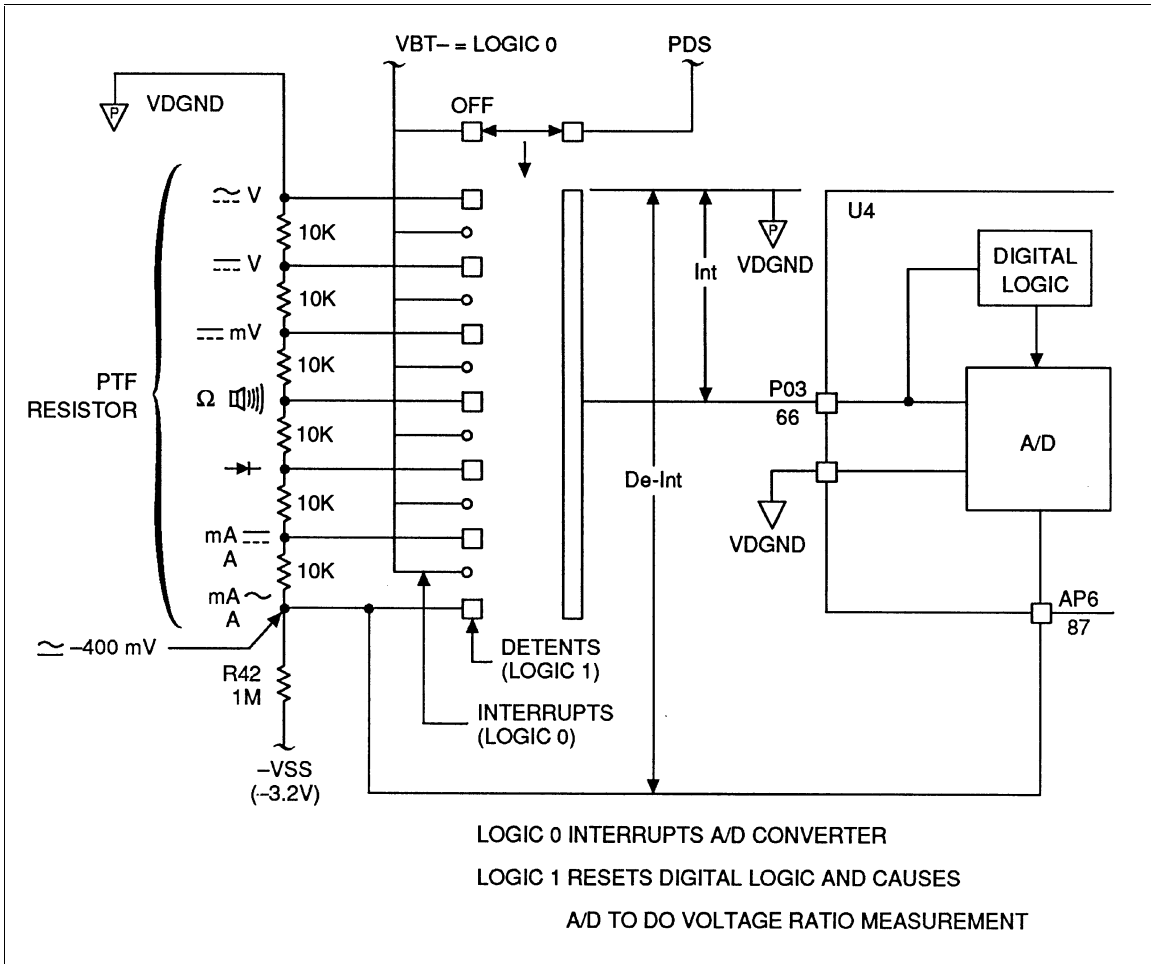

aad4f.tif

Figure 2-3. Function-Encoding Switch



## **Chapter 3**

# **Maintenance**

	<b>Title</b>	<b>Page</b>
3-1.	Introduction .....	3-3
3-2.	Required Tools and Equipment.....	3-3
3-3.	Operator Maintenance .....	3-4
3-4.	Disassembling the Case.....	3-5
3-5.	Removing and Reinstalling the Circuit Assembly .....	3-5
3-6.	Reassembling the Case.....	3-6
3-7.	Replacing the Battery.....	3-7
3-8.	Testing Fuses .....	3-7
3-9.	Replacing Fuses .....	3-7
3-10.	Cleaning .....	3-8
3-11.	Input Terminals.....	3-8
3-12.	Function Encoding Potentiometer .....	3-8
3-13.	Performance Test.....	3-9
3-14.	Testing the Display .....	3-9
3-15.	Testing Function Selection (Rotary Switch).....	3-10
3-16.	Testing the AC Voltage Function .....	3-10
3-17.	Testing the Frequency Counter Function.....	3-11
3-18.	Testing Frequency Sensitivity and Trigger Level.....	3-12
3-19.	Testing the DC Voltage Function .....	3-12
3-20.	Testing the DC mV Function .....	3-13
3-21.	Testing the Ohms Function .....	3-13
3-22.	Testing the Diode Test Function.....	3-13
3-23.	Testing the mA Functions .....	3-13
3-24.	Testing the Amp Functions .....	3-14
3-25.	Testing the Inductive Pickup.....	3-14
3-26.	Calibration.....	3-18
3-27.	Troubleshooting the Power Supply .....	3-19
3-28.	Common (Shunt) Regulator Troubleshooting.....	3-21
3-29.	VDD (Series) Regulator Troubleshooting .....	3-23
3-30.	Troubleshooting a Function Selection Malfunction.....	3-23
3-31.	Meter Does Not Turn Off (Problem 1) .....	3-24
3-32.	Meter Enters Wrong Function (Problem 2) .....	3-24



### 3-1. Introduction

#### Warning

Service procedures described in section 3 should be performed by qualified service personnel only. To avoid electrical shock, do not perform any servicing unless you are qualified to do so.

Chapter 3 covers the following procedures:

- Maintenance
- Disassembly and reassembly
- Performance testing
- Calibration
- Troubleshooting to the component level

### 3-2. Required Tools and Equipment

Required equipment is listed in Table 3-1. If the recommended models are not available, equipment with equivalent specifications may be used. Repairs or servicing should be performed only by qualified personnel.

**Table 3-1. Required Equipment**

Equipment	Required Characteristics	Recommended Model
DMM Calibrator	AC Voltage Range: 0-1000V ac Accuracy: $\pm 0.3\%$ Frequency Range: 50-10000 Hz Accuracy: $\pm 1\%$ DC Voltage Range: 0-1000 V dc Accuracy: $\pm 0.3\%$ Current Range: 34-350 mA Accuracy: $\pm 2\%$ Resistance Range: 190 $\Omega$ -100 M $\Omega$ Accuracy: 0.1% Current Range: 10A Accuracy AC (60 Hz to 1 kHz): $\pm 0.35\%$ DC $\pm 0.3\%$	Fluke 5500A
Function Generator	Triangle Wave N Cycle (Single Cycle) 1 MHz 20 V Output unterminated	Philips PM5133 or 5134
Oscilloscope	60 MHz, 30% vertical error 10M scope probe	Philips PM 3055
Adapter	Binding Post to BNC Male	Pomona Model 1296
10-Ohms Resistor	$\pm 1\%$	NA
14-AWG Wire	1-ft, insulated	NA

Table 3-1. Required Equipment (cont)

Equipment Used in Performance Tests			
Performance Test	DMM Calibrator	Function Generator	Oscilloscope
AC Voltage	X		
Frequency			
Accuracy		X	
Sensitivity		X	
Trigger Level		X	
DC Voltage	X		
mV DC	X		
Ohms	X		
Diode Test	X		
mA	X		
A	X		
RPM/Inductive Pickup		X	X

### 3-3. Operator Maintenance

#### Warning

To avoid electrical shock, remove the test leads and any Input signals before replacing the battery or fuses. To Prevent damage or injury, install only quick-acting fuses With the amp/volt ratings shown in Figure 3-1.

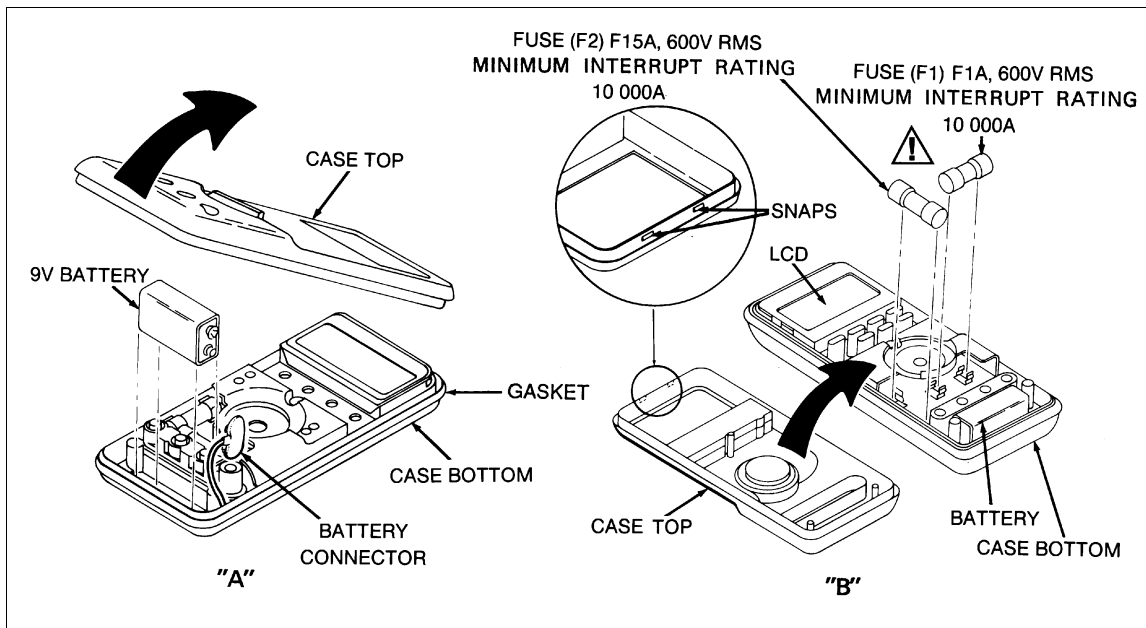

Figure 3-1. Battery and Fuse Replacement

aad05f.tif

**3-4. Disassembling the Case**

Perform the following procedure to disassemble the case:

1. Disconnect the test leads from any live source, turn the Meter rotary switch to OFF, and remove the test leads from the front terminals.
2. The case top is secured to the case bottom by three screws and two internal snaps (at the LCD end). Using a Phillips-head screwdriver, remove the three screws from the case rear.

*Note*

*The gasket between the case top and case bottom is sealed to the case bottom. The case top lifts away from the gasket easily. Do not damage the gasket or attempt to separate the gasket from the case bottom.*

3. Turn the case over (display side up), and, lifting up on the input terminal end, disengage the case top from the gasket. Gently unsnap the case top at the display end. See Figures 3-1 and 3-2.

**Caution**

**With its case removed, circuit connections are exposed. To avoid unintended circuit shorting, always place the uncovered Meter assembly on a protective surface.**

**3-5. Removing and Reinstalling the Circuit Assembly**

After the outer case has been removed, perform the following procedure to disconnect the covering shields from the circuit assembly:

1. Unsnap the battery from the battery connector.
2. Carefully remove the assembly from the case bottom and turn the assembly over.
3. Remove the one Phillips-head screw securing the back shield to the circuit assembly. Then remove the back shield.
4. The front shield can now be disconnected from the circuit assembly by detaching the four snaps (one at a time) found on the front shield.

**Caution**

**Detach the four securing snaps gently. Excessive force can deform or fracture the snaps.**

5. To reattach the circuit assembly, push the front shield on so that the four clips engage gently and simultaneously. Then turn the assembly over, and replace the back shield and Phillips-head screw.

*Note*

*Ensure that the shields are tightly attached. Meter accuracy depends on properly fitted shields.*

6. Gently place the assembly back in the case bottom.
7. Snap the battery to the battery connector and reinsert the battery in the case bottom.

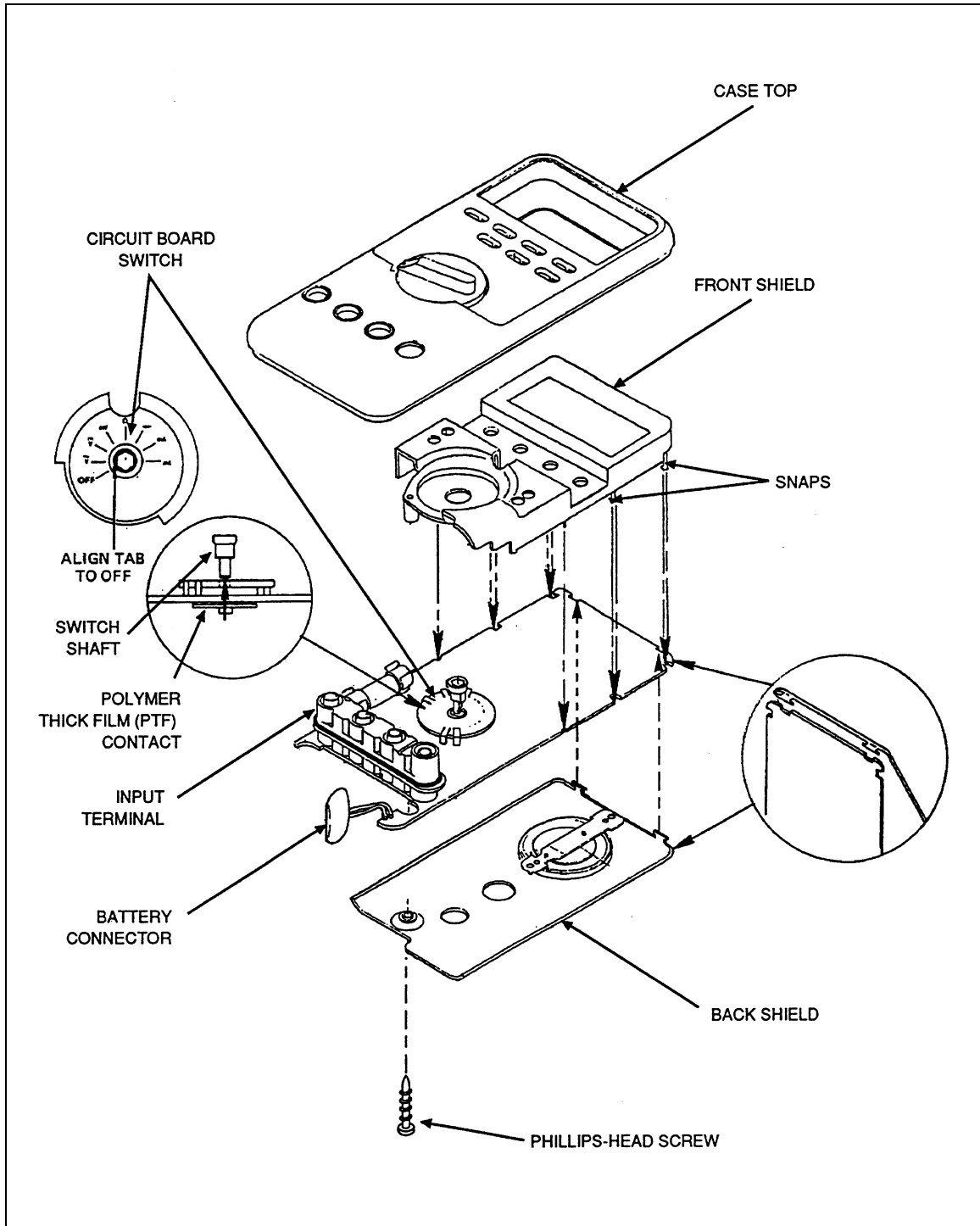

Figure 3-2. Assembly Details

aad06f.wmf

### 3-6. Reassembling the Case

Perform the following procedure to reassemble the case:

1. Make sure that the Meter rotary switch and circuit board switch are in the OFF position (see Figure 3-2).

2. Dress the battery leads so that they will not be pinched between the case top and bottom.
3. Ensure that the gasket remains secured to the case bottom.
4. Starting with the two snaps at the display end and finishing at the terminal end, cradle the case top into the gasket.
5. Reinstall the three screws from the case bottom.
6. Execute the PERFORMANCE TEST procedures later in Chapter 3.

### **3-7. Replacing the Battery**

#### **⚠ Warning**



**To avoid false readings, which could lead to possible electric shock or personal injury, replace the battery as soon as the battery indicator (  ) appears.**

The meter is powered by a single 9 V battery (NEDA 1604, 6F22, or 006P). Referring to Figure 3-1, perform the following procedure to replace the battery:

1. Remove the Meter case as described previously under "Disassembling the Case".
2. Lift the battery from the case bottom, and carefully unsnap the battery from the battery connector.
3. Snap the battery connector to the terminals of a new battery and reinsert the battery into the case bottom. Dress the battery leads so that they will not be pinched between the case bottom and case top.
4. Reassemble the Meter as described under "Reassembling the Case".

### **3-8. Testing Fuses**

Perform the following procedure to test the internal fuses of the Meter.

1. Set the Meter rotary switch to  Ω.
2. Plug a test lead into the **VΩ**  input terminal, and touch the probe to the A input terminal. Because the receptacles of the input terminals contain split contacts, be sure that you touch the probe to the half of the receptacle contact that is nearest the LCD.
3. The display should read between 00.0 and 00.5 ohms. This tests F2 (15 A, 600 V). If the display reads OL (overload), replace the fuse and test again. If the display reads any other value, further servicing is required.
4. Move the probe from the A input terminal to the mA input terminal. Touch the half of the receptacle that is nearest the LCD.
5. The display should read between 0.995 kΩ and 1.005 kΩ. This procedure tests F1 (1 A, 600 V). If the display reads a high resistance or OL (overload), replace the fuse and test again. If the display reads any other value, further servicing is required.

### **3-9. Replacing Fuses**

#### **⚠ Warning**

**To prevent equipment damage or injury, install ONLY specified replacement fuses with the amperage, voltage, interrupt, and speed ratings listed in the List of Replaceable Parts later in this manual.**

Referring to Figures 3-1 and 3-2, perform the following procedure to examine or replace the meter's fuses:

1. Perform steps 1 through 3 of the battery replacement procedure.
2. Remove the defective fuse by gently prying one end of the fuse loose and sliding the fuse out of the fuse bracket.
3. Install a new fuse of the same size and rating. Make sure the new fuse is centered in the fuse holder.
4. Make sure that the Meter rotary switch and circuit board switch are in the OFF position.
5. Ensure that the gasket remains secured to the case bottom. Then, starting with the two snaps at the display end and finishing at the terminal end, cradle the case top into the gasket.
6. Reinstall the three screws from the case bottom.

### 3-10. *Cleaning*

#### **Warning**

**To avoid electrical shock or damage to the meter, never allow water inside the case. To avoid damaging the meter's housing, never use solvents on the meter.**

If the Meter requires cleaning, wipe it with a cloth that is lightly dampened with water or a mild detergent. Do not use aromatic hydrocarbons, chlorinated solvents, or methanol-based fluids on the Meter.

### 3-11. *Input Terminals*

Water, dirt, or other contamination in the A or mA terminals may activate the Input Alert (beeper) even though test leads are not inserted. Such contamination can sometimes be dislodged by turning the Meter over and gently tapping on the case. However, Fluke recommends the following procedure as a much more effective treatment:

1. Turn the Meter off and remove all test leads.
2. Use a clean swab in each of the four terminals to dislodge and clean out the contamination.
3. Moisten a new swab with a cleaning and oiling agent (such as WD40). Work this swab around in the A and mA input terminals. The oiling agent insulates the terminals from moisture-related shorting. This preventive treatment ensures against future erroneous Input Alerts.

### 3-12. *Function Encoding Potentiometer*

Perform the following procedure to clean the rotary switch potentiometer, which is screened on the back of the pca:

1. Remove the circuit assembly as described previously in this section under "Removing and Reinstalling the Circuit Assembly".
2. From the back of the circuit assembly, push the switch shaft in (see Figure 3-2), and remove the polymer thick-film (PTF) contact assembly.
3. Push and secure the ptf contact assembly back on the switch shaft.



4. Reassemble the circuit assembly, shields, and case parts as described previously in this section under "Removing and Reinstalling the Circuit Assembly" and "Reassembling the Case".
5. Execute the PERFORMANCE TEST after reassembly.

### 3-13. Performance Test

Perform the following procedure to check basic Meter operations:

1. Turn the Meter rotary switch to  $\Omega$ .
2. Plug a test lead into the  $V\Omega \rightarrow$  input. Using the probe end of the test lead, touch the half of the input contact nearest the LCD of the mA input.

The display should read  $1.000 \text{ k}\Omega \pm 5$  digits.

3. Remove the test probe from the mA input.
4. Push the ALERT key on the bottom row of the softkeys.
5. Place the test probe in the A input, touching the contact nearest the LCD.

The beeper sounds if the mA fuse (15A) is good.

The following paragraphs provide a more complete check of the Meter's accuracy and operability. The accuracy of each Meter function is compared to the specifications for that function listed in Chapter 1 of this manual. The case covers do not need to be removed and no adjustments are necessary. Merely make the input connections called for, and read the display. If the Meter fails any of the performance tests below, calibration adjustment and/or repair is required.

The equipment required to perform these tests is listed in Table 3-1. Specified accuracy is maintained for a period of one year after calibration, at an operating temperature of  $18^{\circ}\text{C}$  to  $28^{\circ}\text{C}$  and at a maximum of 90% relative humidity.

### 3-14. Testing the Display

With the Meter rotary switch in the OFF position, press and hold down any pushbutton and turn the rotary switch to any function setting.

The display should appear as shown in Figure 3-3.

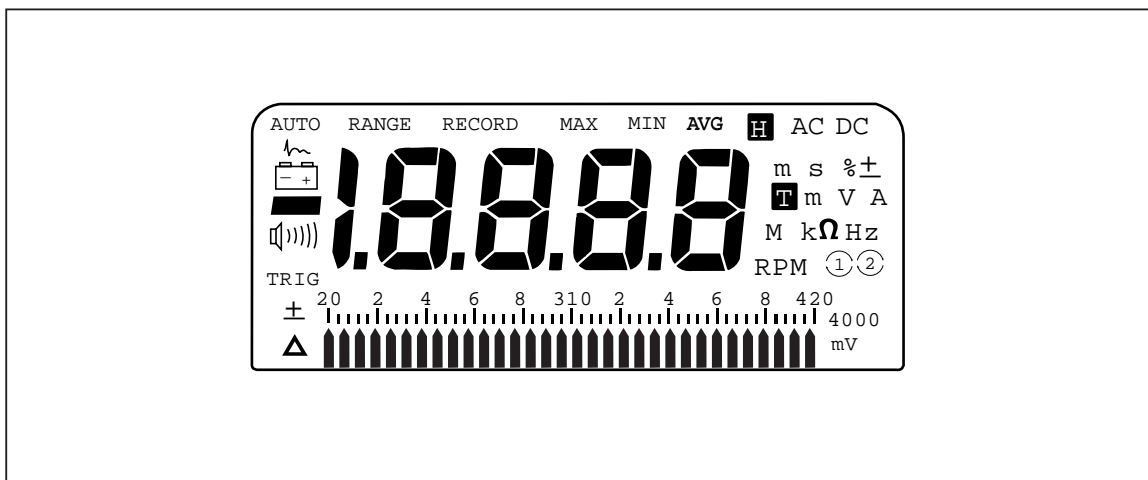

Figure 3-3. Display Test

aad07f.eps

### 3-15. Testing Function Selection (Rotary Switch)

The function selection test checks the operation of the rotary switch function selector circuit.

The selector circuit relies on the interface between a PTF region on the circuit assembly and a rotating contact assembly on the switch shaft. The function selection test exercises this interface by checking the various range codes and displaying their representative numbers.

Perform the following procedure to test the function selector circuit.

1. Press and hold down **RPM** pushbutton while turning the rotary switch from OFF to **~V**.  
This enables the function selection test and disables normal Meter functions. [T] (for test) is shown on the display, and a number appears in the display.
2. Compare the display reading with the value for **~V** shown in Table 3-2. This reading should be within  $\pm 12$  of the number for **~V** in Table 3-2. If it is not, refer to Troubleshooting A Function Selection Malfunction later in Chapter 3.
3. Rotate the switch to **≡ V**. The display reading should be within  $\pm 12$  of the **≡ V** value shown in Table 3-2.
4. Test the remaining function settings on the rotary switch as in step 3.
5. To exit the function selection test, turn the rotary switch to OFF, then turn it to any switch setting.

Table 3-2. Function Selection Test

Function	Display ( $\pm 12$ )
OFF	n/a
~V	0
≡ V	-32
≡ mV	-64
$\Omega$	-96
→	-128
mA≡~	-160
$\mu$ A≡~	-192

### 3-16. Testing the AC Voltage Function

Perform the following procedure to verify accuracy of voltage ranges.

1. Connect the calibrator to the **V $\Omega$ →** and COM inputs on the Meter.
2. Set the meter rotary switch to **~V** and press the range button for two seconds to select the auto-range.
3. Set the calibrator for the voltage and frequency called for in step 1 of Table 3-3. The display reading should be within the limits shown in Table 3-3.
4. Repeat the previous step (Step 2) for steps 2 through 14 of Table 3-3.
5. Turn the meter off.

**Table 3-3. AC Voltage Test**

Step	Input		Display Reading Limits
	Voltage	Frequency	
1	350.0 mV	60 Hz	343.7 to 356.3
2	350.0 mV	1 kHz	343.7 to 356.3
3	350.0 mV	5 kHz	342.3 to 357.7
4	3.500 V	60 Hz	3.442 to 3.558
5	3.500 V	1 kHz	3.442 to 3.558
6	3.500 V	5 kHz	3.428 to 3.572
7	35.00 V	60 Hz	34.42 to 35.58
8	35.00 V	1 kHz	34.42 to 35.58
9	35.00 V	5 kHz	34.28 to 35.72
10	350.0 V	60 Hz	344.2 to 355.8
11	350.0 V	1 kHz	344.2 to 355.8
12	350.0 V	5 kHz	342.8 to 357.2
13	900 V	60 Hz	872 to 928
14	900 V	5 kHz	872 to 928

**3-17. Testing the Frequency Counter Function**

Perform the following procedure to verify the accuracy in frequency counterfunctions.

1. Connect the function generator to the **VΩ→** and COM inputs on the Meter.
2. Turn the rotary switch to **~V**, and press the RANGE button four times to put the Meter in the 400 mV ac range.
3. Press the RPM (Hz) pushbutton three times to select the frequency function.
4. Set the function generator for the sine wave voltage and frequency called for in step 1 of Table 3-4. The value displayed should be within the limits shown in step 1 of Table 3-4. Repeat for step 2.

**Table 3-4. Frequency Test**

Step	Sine Wave Input		Display Reading Limits
	Voltage	Frequency	
1	150 mV rms	19.000 kHz	18.997 to 19.003
2	150 mV rms	190.00 kHz	189.97 to 190.03

### 3-18. Testing Frequency Sensitivity and Trigger Level

The following procedure verifies the counter sensitivity and trigger levels for all frequency modes and ranges. For any function and range, the sensitivity and trigger level is the same in both frequency and duty cycle modes.

1. Connect the DMM calibrator to the **V $\Omega$ →** and COM inputs on the Meter.
2. Select the 4 V ac range, and press the RPM button to choose the frequency mode.
3. Apply the input from step 1 of Table 3-5, and check for the called-for response.
4. Select the 4 V dc range, and press the RPM button to select frequency mode.
5. Apply the input from step 2 and step 3 of Table 3-5, and check for the called-for response.
6. On the Meter, press the RANGE button to enter the 40V dc range.
7. Apply the step 4 and step 5 input and check for the called-for responses on the Meter.

**Table 3-5. Frequency Counter Sensitivity and Trigger Level Tests**

Step	Range	Amplitude (RMS)	Frequency	Display Reading
1	4 V ac	300 mV ac	1 kHz	999.8 - 1000.2
2	4 V dc	1.7 V ac	1 kHz	999.8 - 1000.2
3	4 V dc	1.0 V ac	1 kHz	0000
4	40 V dc	6.0 V ac	1 kHz	999.8 - 1000.2
5	40 V dc	2.0 V ac	1 kHz	0000

**Table 3-6. DC Voltage Test**

Step	DC Input Voltage	Display Reading
1	3.500 V	3.493 to 3.507
2	35.00 V	34.93 to 35.07
3	-35.00 V	-34.93 to -35.07
4	350.0 V	349.3 to 350.7
5	1000 V	995 to 1005

### 3-19. Testing the DC Voltage Function

Perform the following procedure to verify the accuracy of dc voltage measurements. (A separate verification procedure for dc millivolts (mV) is provided later in this section.)

1. Connect the calibrator to the **V $\Omega$ →** and COM inputs on the Meter.
2. Set the Meter rotary switch to **V**.
3. Refer to Table 3-6. Apply the inputs in steps 1 through 5 and compare the Meter's response with the values shown.

**3-20. Testing the DC mV Function**

Perform the following procedure to verify the accuracy of dc millivolt measurements.

1. Connect the calibrator to the **VΩ→** and COM inputs on the Meter.
2. Set the Meter rotary switch to **mV**.
3. Apply 350.0 mV. The display should read between 349.3 and 350.7 mV.

**3-21. Testing the Ohms Function**

Perform the following procedure to verify the accuracy of resistance measurements.

1. Connect the resistance calibrator to **VΩ→** and COM on the Meter.
2. Set the Meter rotary switch to **Ω**.
3. Refer to Table 3-7. Apply the inputs in steps 1 through 4 and compare the display reading with the values shown.
4. Press the RANGE button twice to enter the 400-MΩ range used for conductance tests of high resistances. Then proceed with step 5 of Table 3-7.

**Table 3-7. Ohms Test**

Step	Resistance	Display Readings
1	190.0 Ω	189.5 to 190.5
2	19.00 kΩ	18.95 to 19.05
3	1.900 MΩ	1.895 to 1.905
4	19.00 MΩ	18.78 to 19.22
5	100 MΩ	97 to 103

**3-22. Testing the Diode Test Function**

Perform the following procedure to check the diode test function:

1. Set the Meter rotary switch to **→**.
2. Connect the calibrator to the **VΩ→** and COM inputs on the Meter.

*Note*

*On Fluke 5100 series calibrators, activate the 50Ω divider override. On the 5500A calibrators, lock voltage to the 33 V range.*

3. Apply 3.000V.  
The display should show 3.000V ± 0.062V dc.

**3-23. Testing the mA Functions**

Perform the following procedure to verify the accuracy of mA (ac and dc) measurements:

1. Connect the calibrator to the **mA** and **COM** inputs on the Meter.
2. Set the Meter rotary switch to **mA A**.
3. Refer to Table 3-8. Apply the inputs in steps 1 and 2 and compare the display reading with the values shown.
4. Set the Meter function to **mA A ~**.

- Apply the inputs in steps 3 through 6 and compare the display reading with the values shown.

Table 3-8. Milliamp Tests

Step	DC mA	Display Readings	
1	35.00 mA	34.70 to 35.30	
2	350.0 mA	347.0 to 353.0	
	AC mA	Frequency	Display Readings
3	35.00 mA	60 Hz	33.85 to 36.15
4	35.00 mA	1.0 kHz	33.85 to 36.15
5	350.0 mA	60 Hz	339.0 to 361.0
6	350.0 mA	1.0 kHz	339.0 to 361.0

### 3-24. Testing the Amp Functions

Perform the following procedure to verify the accuracy of A (ac and dc) measurements.

- Set the calibrator output to 0 amps.
- Set the Meter rotary switch to **mA A**  $\overline{\text{=}}$  .
- Connect the calibrator to the A and COM inputs of the Meter.
- Refer to Table 3-9. Apply the inputs in steps 1 and 2, and compare the display reading with the values shown.
- Set the calibrator output to 0 amps, and set the Meter rotary switch to **mA A**  $\sim$  .
- Apply the inputs in steps 3 through 6 and compare the display reading with the values shown.

Table 3-9. Amp Tests

Step	DC Amps	Display Readings	
1	3500 mA	3470 to 3530	
2	10.00 A	9.85 to 10.15	
	AC Amps	Frequency	Display Readings
3	3500 mA	60 Hz	3442 to 3558
4	3500 mA	1.0 kHz	3442 to 3558
5	10.00 A	60 Hz	9.80 to 10.20
6	10.00 A	1.0 kHz	9.80 to 10.20

### 3-25. Testing the Inductive Pickup

To test the inductive pickup, a triangle wave from the function generator will simulate automobile spark plug signals on a loop of wire containing a 10-Ohm resistor. The pickup will be clamped to the wire and output voltage from the pickup will be monitored by an oscilloscope.

Perform the following procedure to test the inductive pickup:

1. Solder a 10-inch piece of 14 AWG wire to each end of a 10-Ohm 1% resistor.
2. Connect the other end of the 10-Ohm resistor to the terminal LOW output of the function generator. Place the other end of the 14-AWG wire to the HIGH output of the function generator. See Figure 3-4.
3. Connect a 10X scope probe from channel 2 (dc-coupled) of the oscilloscope across the 10-Ohm resistor.
4. Clamp the inductive pickup to the wire loop on the HIGH side of the resistor as shown in Figure 3-4.

Make sure that the jaws of the inductive pickup are closed completely, and that the side of the inductive pickup that says "SPARK PLUG SIDE" points toward the HIGH output of the function generator.

5. Connect a 10X scope probe from channel 1 (dc-coupled) of the oscilloscope across the output of the inductive pickup.
6. Set up the function generator as follows:
 

Mod/Sweep Period s	10 ms
Mode	Single (or N Cycle)
Range	2M
Waveform	Triangle
Start Phase	-pi/2
Period	x1
Std By/Cont	Cont
600 Ohm/50 Ohm	50 Ohm
AM/FM Depth	Off
Attenuation	None
Duty Cycle	Out
DC Offset	In
Frequency	0.666 MHz

7. Set the oscilloscope for 0.5V/DIV @ 0.5  $\mu$ s/DIV.
8. Trigger the waveform on channel 2.
9. Adjust the amplitude of the function generator to produce a 3VP-P triangle wave. See Figure 3-5(A).
10. Set the oscilloscope for 1.0V/DIV @ 5.0 ms/DIV.
11. Trigger the waveform on Channel 1.
12. Check that the peak voltage is greater than 6.0V and decays to less than 1.0V between pulses. See Figure 3-5(B).
13. Adjust the peak voltage to 6V using the variable voltage gain control (VAR).
14. Set the scope for 1.0 ms/DIV and trigger waveform.
15. Check the amplitude after 3.0 ms from the waveform peak, the voltage amplitude is 2.4V +0.5/-0.8 (1.6V to 2.9V). (See Figure 3-5(C).)

16. Set the scope for 5.0 ms/DIV and return the variable voltage gain control to the calibrated (CAL) position.
17. Turn the inductive pickup so that "SPARK PLUG SIDE" points along the wire connected to the LOW output of the function generator. Check that the waveform is less than 2V.

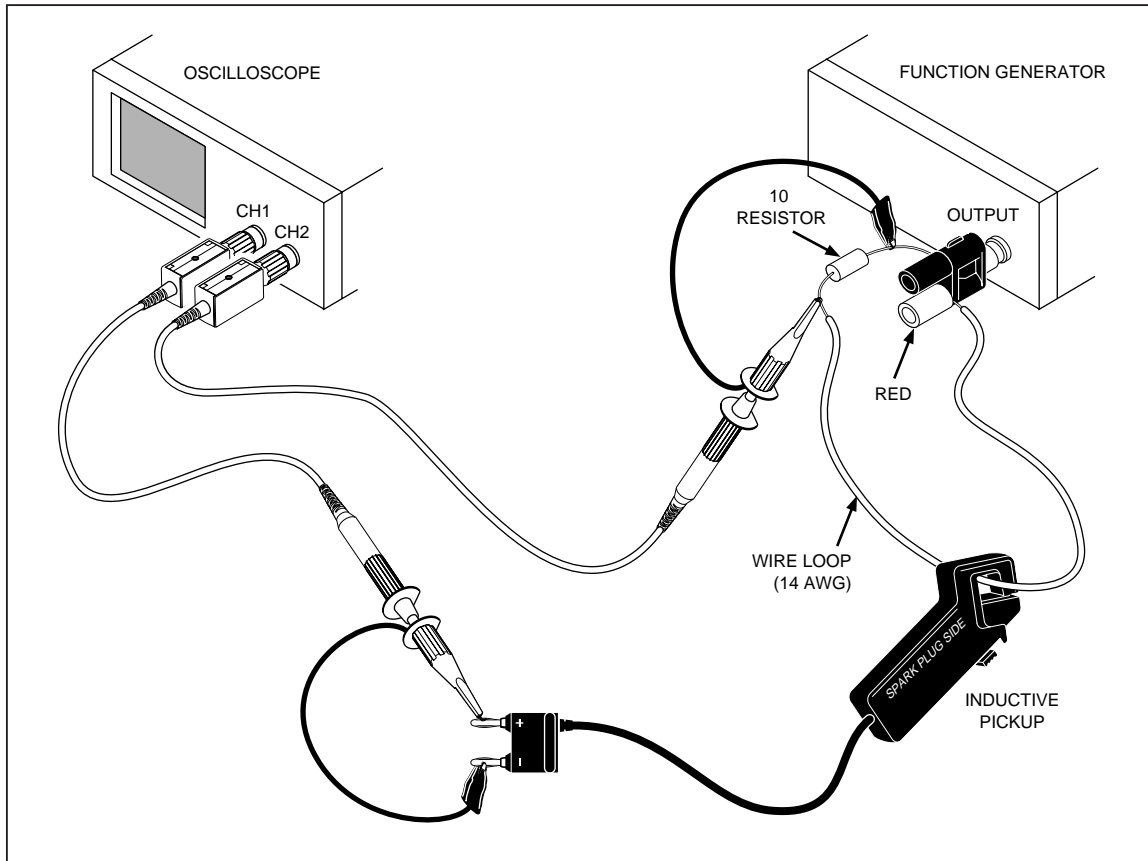

Figure 3-4. Setup for Inductive Pickup Test

aad08f.eps



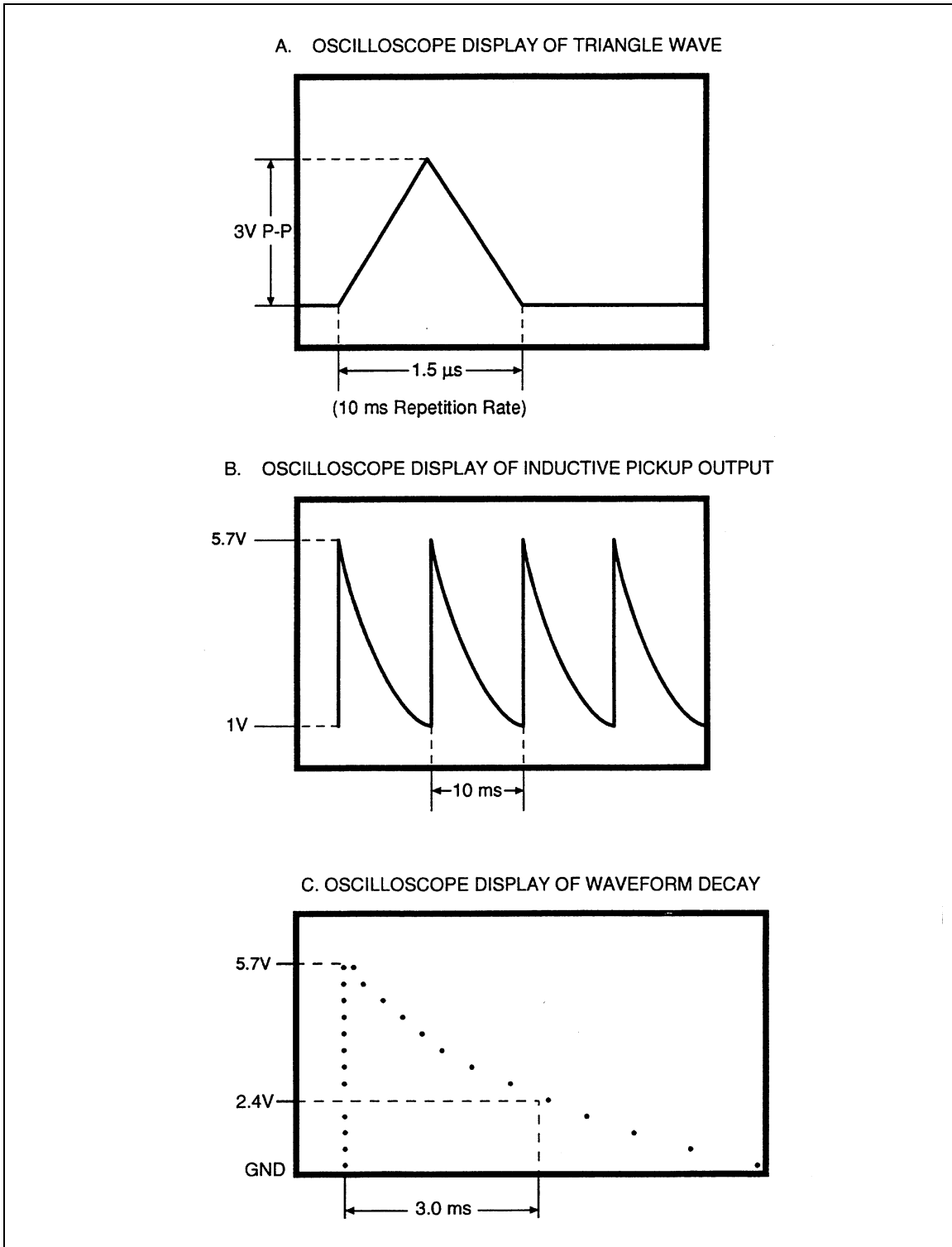

Figure 3-5. Waveform for Inductive Pickup Test

aad09f.wmf

### 3-26. Calibration

Calibrate the meter once a year to ensure that it performs according to specifications. Connect the calibrator to the **V $\Omega$ - $\rightarrow$**  and COM inputs on the Meter. Calibration adjustment points are identified in Figure 3-6.

Perform the following procedure to calibrate the Meter:

1. Set the source for volts dc, 0V.
2. Set the Meter rotary switch to  **$\overline{\text{V}}$** . Press RANGE three times to select the 4V DC range.
3. Connect the source to the **V $\Omega$ - $\rightarrow$**  and COM inputs on the Meter.
4. Set the source for 3.500V dc output.
5. The Meter should display 3.500  $\pm$  0.001. If necessary, adjust R21 to obtain the proper display.
6. Set the Meter rotary switch to  **$\sim$ V**, then set the source for an output of 3.500V at 100 Hz.
7. The Meter should display 3.500  $\pm$  0.002. If necessary, adjust R34 to obtain the proper display.
8. Set the source for an output of 3.500V at 10 kHz.
9. The Meter should display 3.500  $\pm$  0.010. If necessary, adjust C2 to obtain the proper display.
10. Push RANGE once to put the unit in the 40V AC range.
11. Set the source for an output of 35 V at 10 kHz.
12. The Meter should display 35.00  $\pm$  0.10. If necessary, adjust C3 to obtain the proper display.

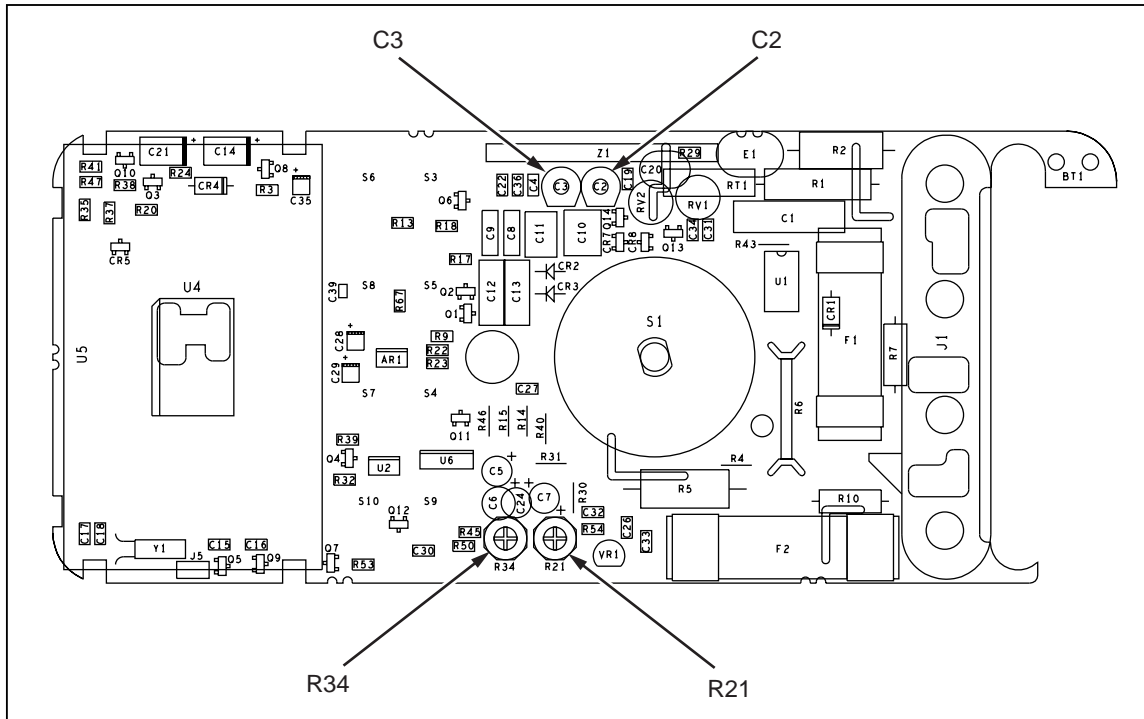

aad10f.eps

**Figure 3-6. Calibration Adjustment Points**

### **3-27. Troubleshooting the Power Supply**

If the Meter fails, check the battery and fuses and replace as needed. If problems still persist, review the operating instructions in the Users Manual. If these measures suggest a fault with the Meter, consult the TROUBLESHOOTING THE POWER SUPPLY procedures that follow and the signal flow diagrams in Chapter 5.

The two regulator circuits are interrelated; a malfunction in either the common regulator or the VDD regulator may cause a problem in the other. Refer to Tables 3-10 and 3-11 for descriptions of power supply components and voltage levels, respectively. To isolate the problem regulator circuit, disconnect the battery, and drive  $VDD - VSS = 6.2V$  with a power supply. This procedure tests the common regulator independently of the VDD regulator.

Now check for  $VDGND - VSS = -3.2V \pm 0.3V$ . If this test is successful, the problem lies with the VDD regulator; refer to "VDD (Series) Regulator Troubleshooting" later in this section. If this test is not successful, the problem lies with the common regulator; continue with the "Common (Shunt) Regulator Troubleshooting" below.

Note that if the common regulator works or has been repaired, check both supplies with the 9V battery supply.

Table 3-10. Functional Description of Power Supply Components

Component	Function
Q3	Vdd Regulator series regulator device
Q8	Power on/off device
Q10	Power supply startup device. Q10 provides Q8 base startup current. Q10 is always off during meter operation.
CR5	CR5 is in the power supply series loop, allowing for generation of Vbt=+3.6V for diode test.
VR1	VR1 provides the system reference voltage. It is used for the a/d converter reference and as a reference for both power supply regulators.
C14	VDD regulator compensation and bypass.
C21	Common regulator compensation and bypass.
C32	Q8 gate bypass.
C35	Battery and C5 bypass.
R24, R25	VDD regulator voltage-sensing resistors.
R37, R38	Common regulator voltage-sensing resistors.
R44	Supplies bias current to VR1.
R54	Q8 gate pull-up resistor.

Table 3-11. Voltage Levels

Signal	Typical Voltage Levels
VDD	3.0 ±0.3
VSS	3.2 ±0.3
VBT+	3.5 ±0.3
VBT-	5.5 (battery at full 9 V charge) 3.0 (battery at low charge of 6.5 V)
REFH	1.235 ±0.012
PS0	1.235 ±0.015
PS1	0 ±0.15
AP6	-0.5 to -0.15
VOA	2.2 to 1.7 (referenced from VSS)
VOB	1.07 to .85 (referenced from VSS)

**3-28. Common (Shunt) Regulator Troubleshooting**

Refer to Figure 3-7 for a simplified diagram of the common regulator. To troubleshoot the common regulator, connect the power supply so that VDD, VSS, and DGND (digital ground) are supplied from an external power supply. This procedure overdrives the large on-chip shunt transistors; the bias current from the power supply ranges from 10 mA to 100 mA. Make the following tests:

1. Check for  $+1.235\text{V} \pm 20\text{ mV}$  (VREFH) at the cathode of VR1. If VREFH is not correct, carefully check VR1, R19, R20, and R44 and the traces to these parts. If VREFH is still incorrect, U4 is bad.
2. If VREFH is correct, measure the voltage at U4 pin 6 (PS1). If VPS1 is not equal to  $0\text{V} \pm 0.15\text{V}$ , check R37 and R38 and their associated traces. If VPS1 is still at an incorrect voltage, U4 is bad.
3. A DGND and VSS current much larger than 100 mA may indicate a problem with Q12 (VDGND-to-VSS quick turn-off clamp) or its base drive signal from U6. The Q12 clamp is off when the Meter is on and on when the Meter is off.
4. Check the bias generator circuit. With the exception of resistor R35 (620 k $\Omega$ ), the bias generator (which sets the bias level for all U4 analog circuitry) is internal to U4. A problem with this circuit could cause the on-chip power supply op amps not to work. Measure the dc voltage between U4 pin 8 (Vbias) and DGND. If  $-0.2\text{V} < \text{Vbias} < +0.2\text{V}$  the bias generator is okay. If Vbias is not correct, check R35. If Vbias is still wrong, replace U4.
5. Measure the ac voltage between VDGND and VSS. If the voltage is greater than 10 mV ac, check C21. (An open C21 causes common regulator instability.) The dc level may also be incorrect.
6. If the common regulator still does not work, circuitry internal to U4 is bad. Replace U4.

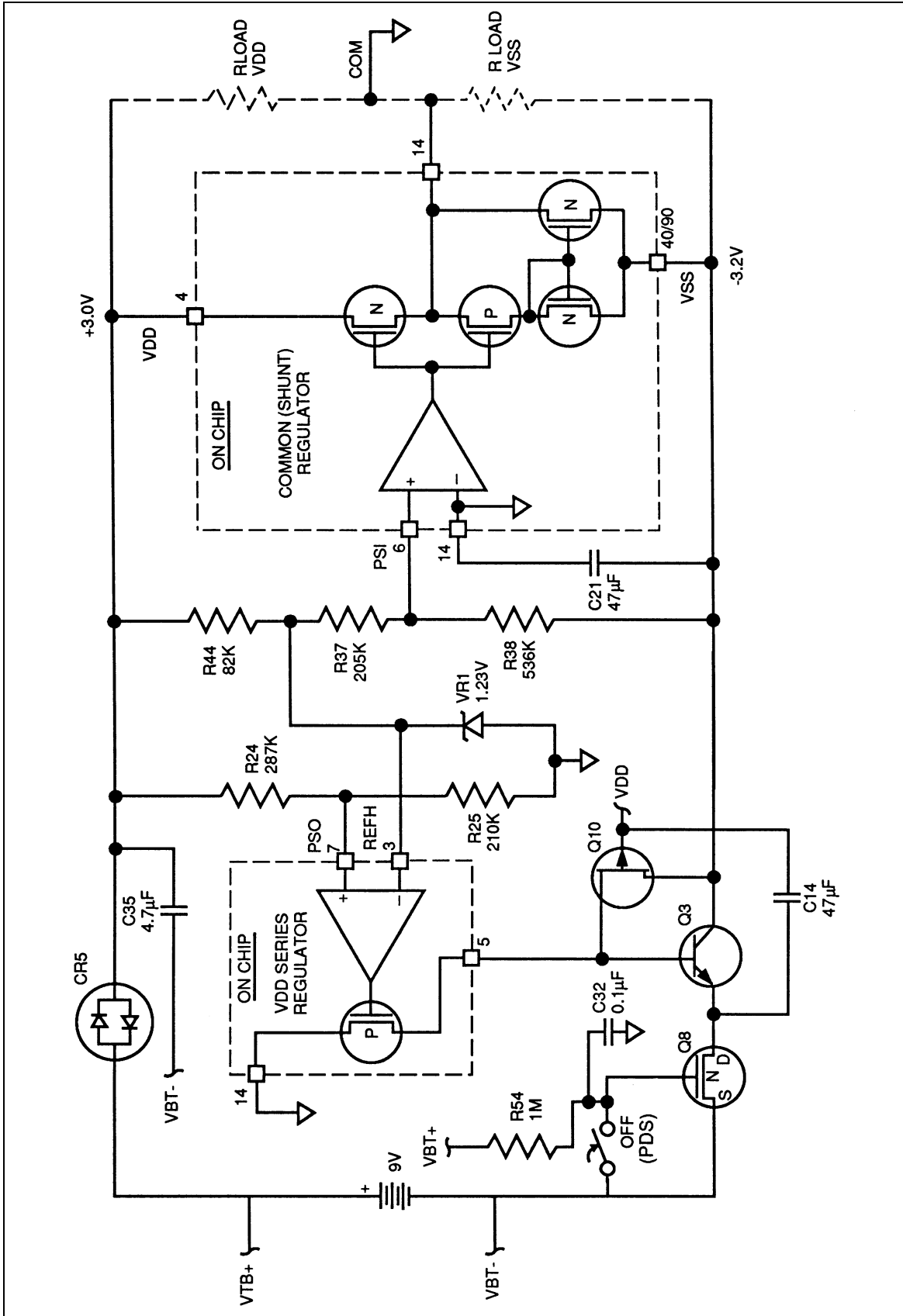

Figure 3-7. Simplified Power Supply Schematic

aad11f.tif

### 3-29. VDD (Series) Regulator Troubleshooting

If a problem still exists after troubleshooting the common regulator, troubleshoot the VDD regulator. Often, a short or sneak current path causes power supply problems. Refer to Figure 3-7 for a simplified diagram of the VDD (Series) Regulator. Make the following tests:

1. Measure the dc operating current from the 9V battery. If it is greater than 1.2, a sneak current path exists. A sneak current path can be very difficult to find.
2. First, visually check for both solder bridges on U4 pins and other circuit board shorts.

Isolate the current path at the negative battery terminal (VBT-). The components connected to VBT- are C35, CR4, R56, U6, Q8, and the rotary switch "fingers". Remove these parts one at a time (except Q8). Measure I(bat) after each removal to isolate the problem.

1. If the excess battery current stops after removing R56, either R56, R57, Q9, or Q11 may be bad. If one of these four parts is bad a problem may not be noticed until U6 is removed.
2. If the extra current is still present with all parts except Q8 removed, remove Q10 and check for excess battery current. If I(bat) is now correct, Q10 is bad. If I(bat) is still excessive, U4 is probably at fault.

If the power supply is not working but battery current is normal, perform the following tests.

1. With the 9V battery attached, cycle the unit off and on. If both supplies are less than 1.0V, a problem probably exists with the on/off circuit. Check Q8, R54, and C32.
2. Check the rotary switch wiper contacts; verify that the Q8 gate voltage is close to VBT+.
3. If VDD - VSS is low, a problem may exist with startup device Q10. Check Q10 by momentarily connecting VSS to VBT-. If both VSS and VBT- now start up and operate correctly, check Q10 for an open.
4. Measure the ac voltage between VDD and VSS. An unstable VDD regulator can be caused by an open C14. If the voltage is greater than 10 mV ac, check C14. The dc level may also be incorrect.

For a final check of U4, remove the battery and supply VDD = +3.0V, VDGND = 0, and VSS = -3.2V from an external power supply. Measure the voltage at U4 pin 7 (VPS0). If it does not equal 1.235V  $\pm$ 0.15 V, check R24 and R25 carefully. If VPS0 is still incorrect, U4 is bad.

### 3-30. Troubleshooting a Function Selection Malfunction

*Note*

*The following information refers to Polymer Thick Film (PTF). For more information refer to "Function-Encoding Potentiometer" in Chapter 2 of this manual.*

Problems related to rotary switch function selection usually manifest themselves in one of two ways:

1. The Meter will not turn off when the rotary switch is in the OFF position.

OR

2. The Meter does not enter the function indicated by the rotary switch setting.

Both of these problems can be intermittent and can be caused by different malfunctions.

### **3-31. Meter Does Not Turn Off (Problem 1)**

If the Meter does not turn off when the rotary switch is in the OFF position, the wiper contacts are probably not making contact with the PTF sections. This may not allow the Power Down Signal (PDS) line to be pulled low by VBT-. Check the wiper contacts for good spring tension against the PTF surface. Make sure that the PTF surface and spring contacts are clean. If they are not, clean them with isopropyl alcohol. To get to the wiper contacts, perform the procedures under "Disassembling the Case" and "Removing and Reinstalling the Circuit Assembly" previously described in Chapter 3.

This problem could be unrelated to the PTF, in which case a power supply component, such as Q8, may be at fault. Refer to TROUBLESHOOTING THE POWER SUPPLY earlier in Chapter 3.

### **3-32. Meter Enters Wrong Function (Problem 2)**

If the Meter does not enter the function indicated by the rotary switch selection, the most probable cause is an out-of-tolerance PTF resistor section. This can be checked by performing the procedure under "Function Selection (Rotary Switch) Test" given earlier in Chapter 3. If the display reading is outside the tolerances given, the PTF resistor section is bad, and the pca must be replaced. (This assumes that the PTF wiper contacts are good. If the wiper contacts are not making proper contact with the PTF sections, the Meter can also select the wrong function. See "Meter Does Not Turn Off", above. However, poor contact is more likely to cause an intermittent rather than a total failure.)

If the Meter powers up in ac mV and will not change functions, the problem is caused by the inability of the a/d converter to measure, NOT BY THE PTF. The a/d converter must do a ratio measurement of the PTF resistor in order to change functions. U4 or one of its peripherals can cause this problem.



## **Chapter 4**

# **List of Replaceable Parts**

	<b>Title</b>	<b>Page</b>
4-1.	Introduction .....	4-3
4-2.	How to Obtain Parts .....	4-3
4-3.	Manual Status Information .....	4-3
4-4.	Newer Instruments.....	4-4
4-5.	Service Centers.....	4-4
4-6.	Parts Lists .....	4-4



## **4-1. Introduction**

This chapter contains an illustrated list of replaceable parts for the Fluke 88 Automotive Meter. Parts are listed by assembly; alphabetized by reference designator. Each assembly is accompanied by an illustration showing the location of each part and its reference designator. The parts lists give the following information:

- Reference designator
- An indication if the part is subject to damage by static.
- Description
- Fluke stock number
- Total quantity
- Any special notes (i.e., factory-selected part)

### **Caution**

**A \* symbol indicates a device that may be damaged by static discharge.**

## **4-2. How to Obtain Parts**

Electrical components may be ordered directly from the manufacturer by using the manufacturers part number, or from the Fluke Corporation and its authorized representatives by using the part number under the heading FLUKE STOCK NO. In the U.S., order directly from the Fluke Parts Dept. by calling 1-800-526-4731. Parts price information is available from the Fluke Corporation or its representatives. Prices are also available in a Fluke Replacement Parts Catalog which is available on request.

In the event that the part ordered has been replaced by a new or improved part, the replacement will be accompanied by an explanatory note and installation instructions, if necessary.

To ensure prompt delivery of the correct part, include the following information when you place an order:

- Instrument model and serial number
- Part number and revision level of the pca containing the part.
- Reference designator
- Fluke stock number
- Description (as given under the DESCRIPTION heading)
- Quantity

## **4-3. Manual Status Information**

The Manual Status Information table that precedes the parts list defines the assembly revision levels that are documented in the manual. Revision levels are printed on the component side of each pca.

#### 4-4. Newer Instruments

Changes and improvements made to the instrument are identified by incrementing the revision letter marked on the affected pca. These changes are documented on a manual supplement which, when applicable, is included with the manual.

#### 4-5. Service Centers

To contact Fluke, call one of the following telephone numbers:

USA: 1-888-99-FLUKE (1-888-993-5853)

Canada: 1-800-36-FLUKE (1-800-363-5853)

Europe: +31 402-678-200

Japan: +81-3-3434-0181

Singapore: +65-738-5655

Anywhere in the world: +1-425-446-5500

Or, visit Fluke's Web site at [www.fluke.com](http://www.fluke.com).

#### 4-6. Parts Lists

The following tables list the replaceable parts for the Fluke 88 Automotive Meter. Parts are listed by assembly; alphabetized by reference designator. Each assembly is accompanied by an illustration showing the location of each part and its reference designator. The parts lists give the following information:

- Reference designator
- An indication if the part is subject to damage by static discharge
- Description
- Fluke stock number
- Total quantity
- Any special notes (i.e., factory-selected part)

#### Caution

**A \*** symbol indicates a device that may be damaged by static discharge.



Note

*This instrument may contain a Nickel-Cadmium battery. Do not mix with the solid waste stream. Spent batteries should be disposed of by a qualified recycler or hazardous materials handler. Contact your authorized Fluke service center for recycling information.*

#### Warning

**This instrument contains a fusible resistor (pn 832550). To ensure safety, use exact replacement only.**

#### Manual Status Information

Assembly	Revision Level
A1 Main PCA	N

Table 4-1. Fluke 88 Final Assembly

Ref Des	Description	Fluke PN	Qty	Notes
A 1	* MAIN PCA	N/A	1	1
BT 1	BATTERY, PRIMARY, ALKALINE, 9V, 0-200MA	614487	1	
CR 6	BACKLIGHT, WHITE	609922	1	
E 1	CONTACT PTF	822676	1	
E 2	CONTACT, ANNUNCIATOR	822791	1	
F 1	FUSE, .406X1.375, 1 A, 600 V, FAST	830828	1	
F 2	FUSE, .406X1.5, 15 A, 600 V, FAST	820829	1	
H 1	SCREW, PH, P, THD FORM, STL, 4-14, .562	832220	1	
H 2	SCREW, PH, P, THD FORM, STL, 5-14, .750	832246	3	
J 1, 2	CONN, ELASTOMERIC, LCD TO PWB, 1.590 L	817460	2	
MP 1	MASK, LCD (PAD XFER)	930300	1	
MP 2	SHIELD, TOP	824516	1	
MP 3	SHAFT, SWITCH	822635	1	
MP 4	SHIELD, BOTTOM	824524	1	
MP 5	CASE TOP & WINDOW ASSY	666641	1	
MP 6	CASE & GASKET ASSY, BOTTOM (CE)	203106	1	
MP 8	KNOB, SWITCH (PAD XFER)	880815	1	
MP 9	SPRING, DETENT	822643	1	
MP 10	FOOT, NON SKID	824466	2	
MP 13	SHOCK ABSORBER	828541	1	
MP 14	O-RING, SYN RUBBER, 1.670 ID, 0.047 WIDE	831933	1	
MP 15	HOLSTER & FLEXSTAND ASSY YELLOW	822809	1	
MP 16	ACCESSORY PACK, FLUKE-88	890368	1	2
MP 17	DECAL, CARRYING CASE	880828	1	
MP 18	CASE, MOLDED, TRANSIT, 86/87/88	875661	1	
MP 22	LABEL, PAPER, 2.00, 3.00	885939	1	
MP 23	SLIP COVER	880831	1	
MP 24	BOX ACCESS, INSERT, 27.00, 4.00, 13.25	876776	1	
MP 30	BOX, SHIP, 4 PANEL, 27.00, 13.25,18.50	876110	1	
R 60	* RESISTOR, SELECTED RC CLOCK	871298	1	
S 2	SWITCHPAD, MOMENTARY	879051	1	
TM 1	MANUAL, FLUKE 88 SERVICE	666856	0	3
TM 5	MANUAL, FLUKE 88 USERS, ENGLISH	666842	1	
TM 6	MANUAL, FLUKE 88 USERS, INTL	666849	1	
U 5	LCD, 4.5 DIGIT, BAR GRAPH, MULTIPLEXED	868088	1	
NOTES:				
1. NON PROCURABLE				
2. ACCESSORY PACK, INCLUDES THE FOLLOWING PARTS:				
	PICK-UP INDUCTIVE, TESTED	890355		
	CLIP, ALLIGATOR, BANANA, INSUL, RED	927749		
	CLIP, ALLIGATOR, BANANA, INSUL, BLK	927756		
	PROBE, TEST, BANANA JACK, RED	927777		
	PROBE, TEST, BANANA JACK, BLK	927772		
	TEST LEAD, SI, R/A STRT, BANANA, RED	927798		
	TEST LEAD, SI, R/A STRT, BANANA, BLK	927793		
3. AVAILABLE THROUGH PARTS DEPARTMENT ONLY.				

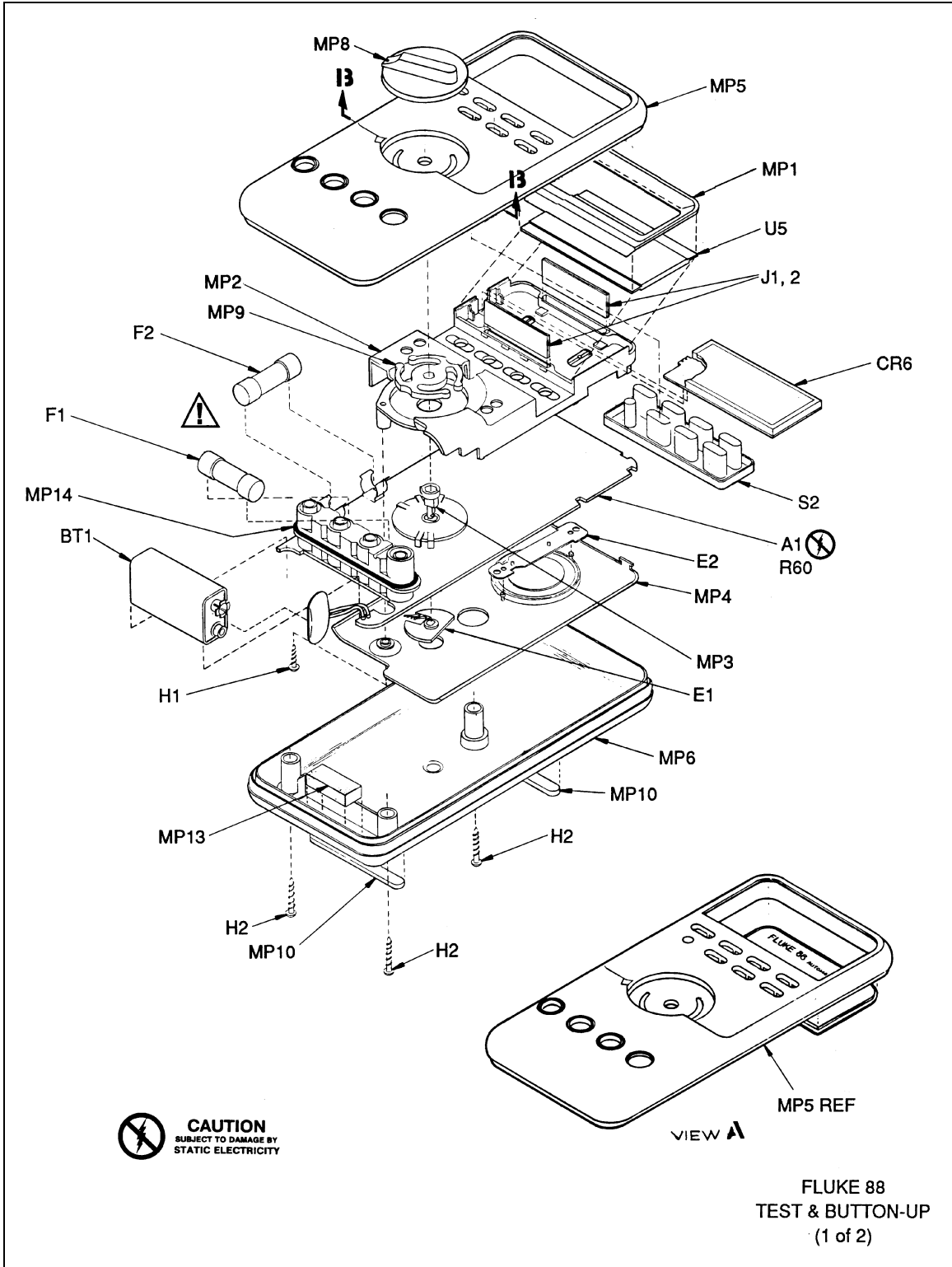

Figure 4-1. Fluke 88 Final Assembly

aad12f.wmf

Table 4-2. A1 Main PCA

Ref Des	Description	Fluke PN	Qty	Notes
C 1	CAP,POLYES,.01UF,+10%,1000V	822361	1	
C 2	CAP,VAR,3-11PF,100V,CER	641712	1	
C 3	CAP,VAR,9-90PF,50V,CER	643130	1	
C 4	CAP,CER,430PF,+2%,50V,COG,1206	851816	1	
C 5	CAP,TA,15UF,+20%,6.3V	807636	1	
C 8, 9	CAP,POLYCA,0.027UF,+10%,63V	720979	2	
C 10	CAP,POLYES,0.47UF,+10%,50V	697409	1	
C 11	CAP,POLYPR,0.022UF,+10%,63V	821579	1	
C 14, 21	CAP,TA,47UF,+20%,10V,7343	867580	2	
C 15, 16, 32	CAP,CER,0.1UF,+10%,25V,X7R,1206	747287	3	
C 17, 18	CAP,CER,22PF,+10%,50V,COG,1206	740563	2	
C 19	CAP,CER,6.8PF,+10%,50V,COG,1206	747295	1	
C 20	CAP,CER,5.6PF,+0.25PF,1500V,COH	851811	1	
C 22	CAP,CER,1000PF,+10%,50V,COG,1206	747378	1	
C 24	CAP,TA,10UF,+20%,10V	714766	1	
C 27	CAP,CER,130PF,+10%,50V,COG,1206	911227	1	
C 28, 29	CAP,TA,0.47UF,+20%,35V,3528	867259	2	
C 30	CAP,CER,220PF,+10%,50V,COG,1206	758078	1	
C 26,31,33,34	CAP,CER,0.01UF,+10%,50V,X7R,1206	747261	4	
C 35, 38	CAP,TA,4.7UF,+20%,10V,3528	867262	2	
C 36	CAP,CER,68PF,+10%,50V,COG,1206	853861	1	
C 39	CAP,CER,150PF,+5%,50V,COG,0805	866533	1	
CR 1, 4	DIODE,SI,1K PIV,1.0 AMP	707075	2	
CR 5, 7, 8	* DIODE,SI,BV=70.0V,IO=50MA,DUAL,SOT23	742320	3	
E 1	SURGE PROTECTOR,1500V,+20%	655134	1	
J 1	INPUT RCPT ASSY	826214	1	
J 2	SOCKET,1 ROW,PWB,0.100CTR,2 POS	832634	1	
Q 1, 2, 6	* TRANSISTOR,SI,NPN,SELECT IEBO,SOT23	821637	3	
Q 3, 7, 9 12	* TRANSISTOR,SI,NPN,SMALL SIGNAL,SOT23	742676	4	
Q 5, 11	* TRANSISTOR,SI,PNP,SMALL SIGNAL,SOT23	742684	2	
Q 8	* TRANSISTOR,SI,N-DMOS FET,SOT23	830851	1	
Q 10	* TRANSISTOR,SI,P-CHAN,SOT23	832477	1	
Q 13, 14	* TRANSISTOR,SI,NPN,SMALL SIGNAL,SOT23	912469	2	
R 1	RES,MF,1K,+1%,100PPM,FLMPRF,FUSIBLE	832550	1	1
R 2	* RES,CERM,909K,+1%,2W,100PPM	831594	1	
R 3	* RES,CERM,1.5K,+5%,.125W,200PPM,1206	746438	1	
R 4, 46	RES JUMPER,0.02,0.25W	682575	2	
R 5	RES,WW,.991,+-.1%,2.5W	821645	1	
R 6	RES,WW,.010,+-.1%,1W,100PPM	807305	1	
R 7, 10	* RES,CERM,1M,+5%,1W,200PPM	912589	2	
R 8	* RES,CERM,0,+05 MAX,.125W,1206	810747	1	
R 9, 13, 29,53	* RES,CERM,100K,+5%,.125W,200PPM,1206	740548	4	
R 11, 48	* RES,CERM,10M,+5%,.125W,300PPM,1206	783274	2	
R 12, 61-66	* RES,CERM,10K,+5%,.125W,200PPM,1206	746610	7	
R 14	RES,MF,10K,+0.1%,0.125W,100PPM	658955	1	
R 15	RES,MF,90K,+0.1%,0.125W,100PPM	658906	1	
R 17, 18, 42, 54	* RES,CERM,1M,+5%,.125W,200PPM,1206	746826	4	
R 19	* RES,CERM,107K,+1%,.125W,100PPM,1206	875224	1	
R 20	* RES,CERM,412K,+1%,.125W,100PPM,1206	875229	1	
R 21	RES,VAR,CERM,100K,+20%,.3W	649897	1	

Table 4-2. A1 Main PCA (cont.)

Ref Des	Description	Fluke PN	Qty	Notes
R 24	* RES,CERM,324K,+/-1%,.125W,100PPM,1206	911243	1	
R 25	* RES,CERM,210K,+/-1%,.125W,100PPM,1206	821660	1	
R 30	RES,MF,20K,+/-0.25%,0.125W,50PPM	715029	1	
R 31, 40	RES,MF,22.6K,+/-0.25%,0.125W,50PPM	715011	2	
R 34	RES,VAR,CERM,1K,+/-20%,.3W	831420	1	
R 35	* RES,CERM,665K,+/-1%,.125W,100PPM,1206	867460	1	
R 37	* RES,CERM,205K,+/-1%,.125W,100PPM,1206	769836	1	
R 38	* RES,CERM,536K,+/-1%,.125W,100PPM,1206	845420	1	
R 43	RES,MF,1K,+/-0.1%,0.125W,100PPM	821694	1	
R 44	* RES,CERM,82K,+/-5%,.125W,200PPM,1206	811794	1	
R 56, 57	* RES,CERM,22K,+/-5%,.125W,200PPM,1206	746651	2	
R 58	* RES,CERM,120K,+/-5%,.125W,200PPM,1206	746719	1	
R 59	* RES,CERM,510,+/-5%,.125W,200PPM,1206	746388	1	
R 67	* RES,CERM,10K,+/-5%,.125W,200PPM,1206	746610	1	
RT 1	THERMISTOR,RECT,POS,1.5K,+/-30%,25 C	822015	1	
RV 1, 2	VARISTOR, 910, +/-10%, 1.0MA	876193	2	
S 1	SWITCH, ROTARY	819334	1	
U 1	DIODE, SI, RECT, BRIDGE, BV= 50V, IO=1A	418582	1	
U 4	* SMX2 AUTOMOTIVE IC	921614	1	
U 6	* IC, CMOS, HEX INVERTER, SOIC	838375	1	
VR 1	IC, 1.23V, 60PPM TC, BAND-GAP REFERENCE	654707	1	
XBT 1	CONNECTOR, BATTERY	825976	1	
XF 1	CONTACT, 600V, FUSE	659524	1	
XF 2	600 VOLT FUSE CONTACT	707190	1	
Y 1	CRYSTAL, 131.072KHZ, 0.003%, 3X8MM	831453	1	
Z 1	RES NET THN F TESTED	872213	1	
NOTES:				
1. THIS IS A FUSIBLE RESISTOR. TO ENSURE SAFETY, USE EXACT REPLACEMENT ONLY.				



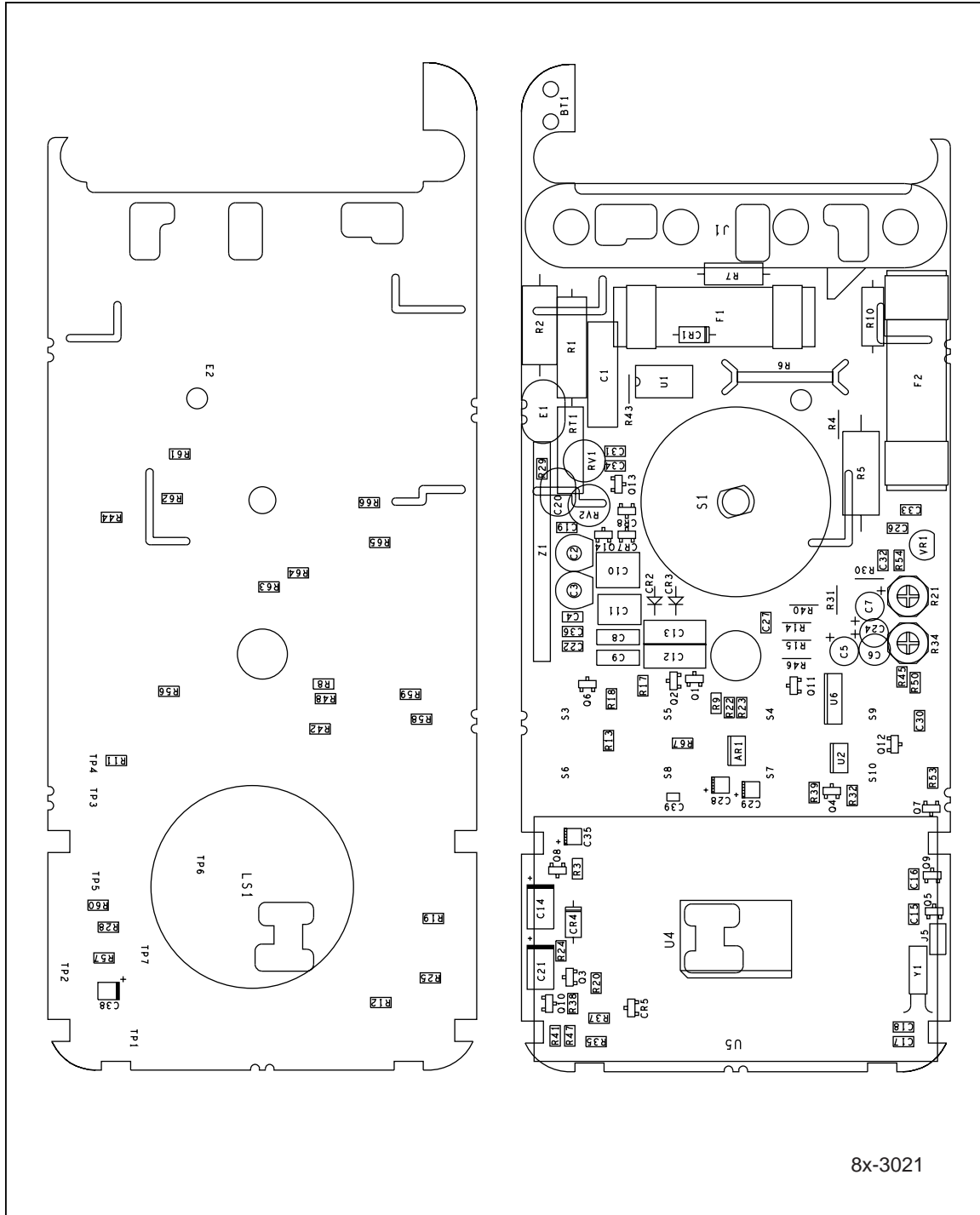

Figure 4-2. A1 Main PCA

aad14f.eps



***Chapter 5***  
***Schematic Diagrams***



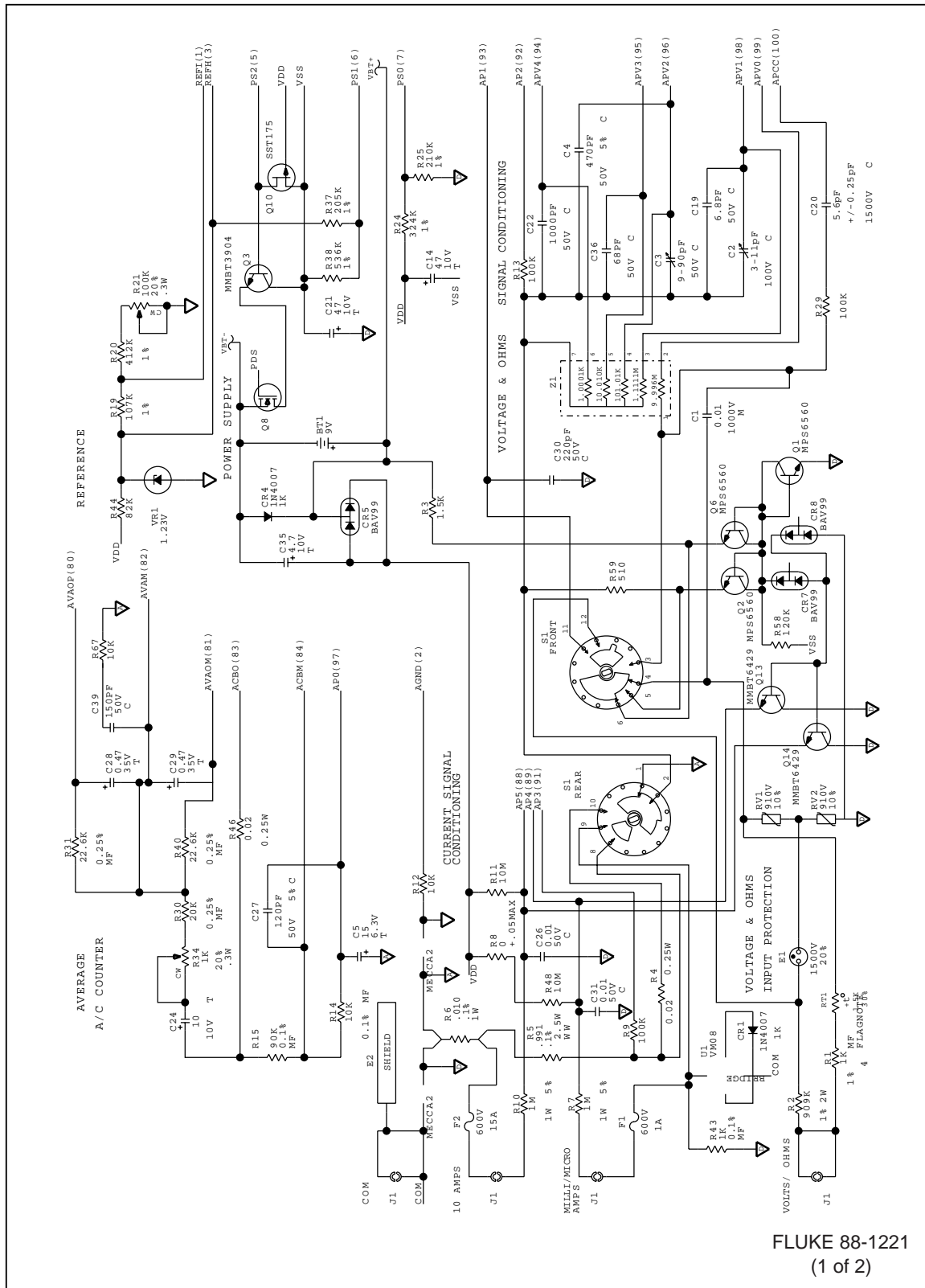

FLUKE 88-1221  
(1 of 2)

Figure 5-1. A1 Main PCA

aad15f.eps

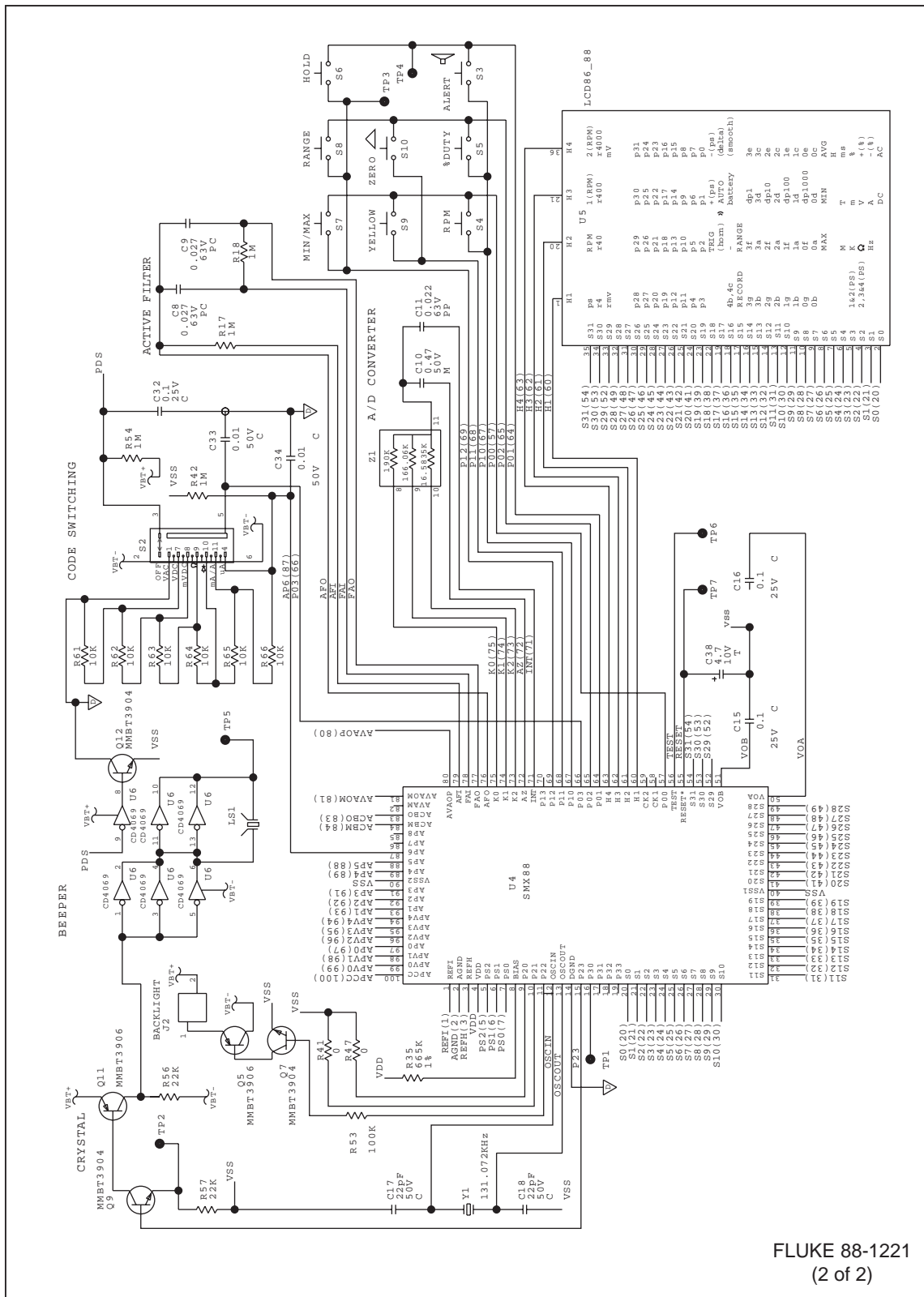

FLUKE 88-1221  
(2 of 2)

Figure 5-1. A1 Main PCA (cont.)

aad16f.eps