

General Description

The Fluke Model C1600 is a rugged, molded plastic case designed for storing and carrying Fluke handheld digital multimeters, process calibrators and most Fluke accessories used with these products.

General Specifications

Dimensions: 13 in x 6.75 in x 10 in
 (33.02 cm x 17.15 cm x 25.4 cm)

Weight: 3 lb 12 oz (1.7 kg)

Warranty: 1-year

Material: Polypropylene

Made in U.S.A.

Features

Refer to Figure 1.

- ① Rubber gasket in the lid seals out dust and keeps the contents dry.
- ② Snap-open compartment on top of lid provides easy access to small parts, such as fuses, batteries, probes and leads.
- ③ Lift-out tray helps keep things organized.
- ④ Five hook-and-loop straps (one shown) for securing cords and test leads when they are not in use. Test leads are not included.
- ⑤ Lid lock (padlock not included).
- ⑥ Deep interior - large enough to hold and protect your gear, accessories, and other essentials.

Using the Hook-and-Loop Straps

1. Hook (attach) the square end of the strap to one end of the cord (or leads).

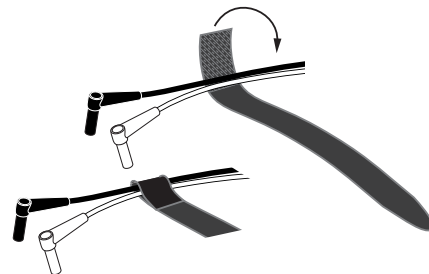

avs002f.eps

2. Loop (wrap) the strap around the rolled up cord (or leads) to secure the bundle.

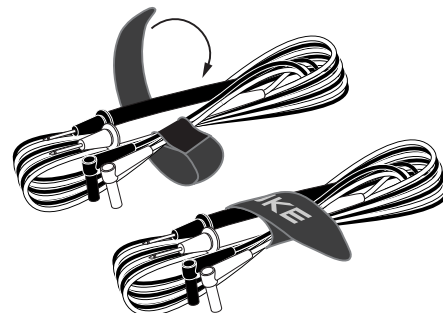

avs003f.eps

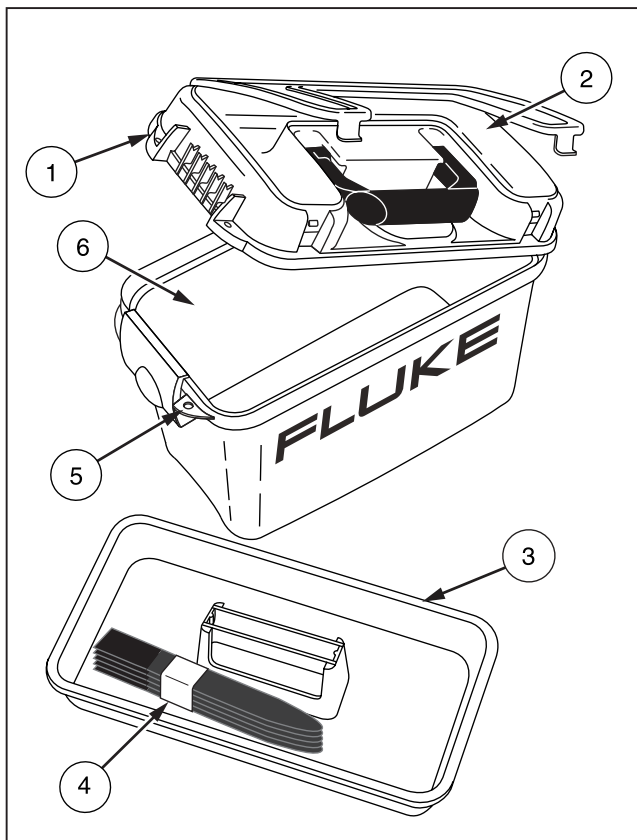

avs001f.eps

Figure 1. Hard Case Features