



205 Westwood Ave  
Long Branch, NJ 07740  
1-877-742-TEST (8378)  
Fax: (732) 222-7088  
salesteam@Tequipment.NET

# NetTool™ Series II

Inline Network Tester

## Getting Started Guide

PN 2631943

September 2006, Rev 1, 6/07

© 2007 Fluke Corporation. All rights reserved. Printed in USA.

All product names are trademarks of their respective companies.

## LIMITED WARRANTY AND LIMITATION OF LIABILITY

Fluke Networks mainframe products will be free from defects in material and workmanship for one year from the date of purchase. Parts, accessories, product repairs and services are warranted for 90 days, unless otherwise stated. Ni-Cad, Ni-MH and Li-Ion batteries, cables or other peripherals are all considered parts or accessories. This warranty does not cover damage from accident, neglect, misuse, alteration, contamination, or abnormal conditions of operation or handling. Resellers are not authorized to extend any other warranty on Fluke Networks' behalf. To obtain service during the warranty period, contact your nearest Fluke Networks authorized service center to obtain return authorization information, then send your defective product to that Service Center with a description of the problem.

THIS WARRANTY IS YOUR ONLY REMEDY. NO OTHER WARRANTIES, SUCH AS FITNESS FOR A PARTICULAR PURPOSE, ARE EXPRESSED OR IMPLIED. FLUKE NETWORKS IS NOT LIABLE FOR ANY SPECIAL, INDIRECT, INCIDENTAL OR CONSEQUENTIAL DAMAGES OR LOSSES, ARISING FROM ANY CAUSE OR THEORY. Since some states or countries do not allow the exclusion or limitation of an implied warranty or of incidental or consequential damages, this limitation of liability may not apply to you.

4/04

Fluke Networks  
PO Box 777  
Everett, WA 98206-0777  
USA

# Table of Contents

Title	Page
About This Guide .....	1
NetTool Product Features .....	2
Safety and Operational Information .....	3
Power Supply .....	4
Using the Batteries and AC Adapter .....	4
Using PoE Power .....	6
Front View .....	7
Left Side View .....	10
Navigation Buttons .....	11
Scrolling .....	11
Paging Up and Down .....	11
Closing the Current Screen .....	11
Accessing Configuration Screens .....	11
Menus .....	12
Network Diagram .....	12
Main Menu .....	14
Setting User Preferences .....	15
Setting User Preferences .....	15
Connecting the Tester .....	16
Single-Ended Connections .....	16
Patch Cable Test .....	17
Wiremap .....	17
Toner .....	18
Inline Connection .....	19
AutoTest .....	20
Cable Test Results .....	21
Wiremap Test Results .....	21
Service Identification Test Results .....	22
Device and Network Test Results .....	22
NetTool Connect .....	24
Updating the Software .....	24
Contacting Fluke Networks .....	25



# *NetTool Series II Inline Network Tester*

---

## *About This Guide*

---

We know that you want to begin using your new NetTool Series II Inline Network Tester right away. This guide provides basic information to help you do just that.

The first section acquaints you with the features of your NetTool Series II Inline Network Tester (hereafter referred to as the tester) and provides quick, easy-to-follow instructions for setting it up. Later sections step you through the basics of connecting the tester, running tests, and viewing results.

For detailed instructions on using your tester, see the *Users Manual*, which is located on the CD that came with your purchase. And, for the latest news, troubleshooting tips, and service information about your tester, go to **[www.flukenetworks.com](http://www.flukenetworks.com)**.

---

## NetTool Product Features

---

Your NetTool tester enables you to diagnose common Layer 1 – 7 problems, giving you total visibility into your network. Specifically, you can:

- Troubleshoot cable problems
- “Listen” to network traffic and gather information about PC and link configurations, network health, and key devices
- Verify connectivity to network devices (PCs, routers, servers, and printers)
- Verify service and monitor call quality on Voice over IP (VoIP) links (Option)
- Detect and measure Power over Ethernet (PoE) voltage and current for both power-supplying equipment (PSE) and powered-devices (PDs).
- Log 802.1X authentication activity (Option). Log onto an 802.1X authenticated network as a client or monitor a host/client authentication session (in-line).
- Inline port monitoring as an effective means of detecting authorized or unauthorized use of ports on your network (Option). Unauthorized use of a port could indicate spyware/malware is running on your network which could indicate theft of passwords, financial information, and confidential files.
- A problem log helps you keep track of all problems detected—from the physical layer to application layer—in a concise, readable manner.

### Note

*The 802.1X and Inline port monitoring features are bundled in the “NetSecure” option. The NetSecure option requires a NetTool Series II with software version 4.50 or greater.*

---

## ***Registering Your NetTool Tester***

---

Please take the time to register your tester. Registration offers you access to support, training, software, and product updates.

Go to the Fluke Networks website at <http://www.flukenetworks.com>. Click the **Register** link and follow the instructions to log in and register your tester online.



---

## ***Safety and Operational Information***

---

To operate your tester safely, observe the usage and disposal warnings represented by the symbols that are found on your tester. The meanings of these symbols are given in the following table.

### **International Electrical Symbols**

	Warning or Caution: Risk of damage or destruction to equipment or software.
	This equipment not for connection to public communications networks, such as active telephone systems.
	Do not put products containing circuit boards into the garbage. Dispose of circuits boards in accordance with local regulations.

---

## Power Supply

---

To supply power to your tester, you can use batteries, the optional AC Adapter, or PoE.

---

### Using the Batteries and AC Adapter

The tester uses four alkaline batteries (supplied) or four rechargeable NiMH batteries (optional).

To install the batteries, remove the yellow boot to access the battery compartment. Open the door and insert the batteries, as shown in the following illustration:

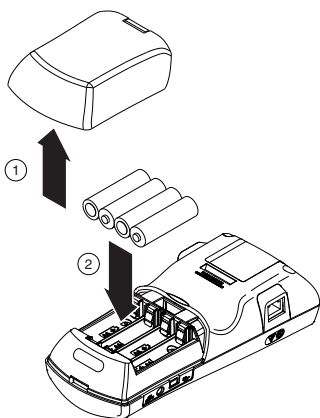

ekd01f.eps



To use AC power, connect the AC adapter to the tester as shown in the following diagram:

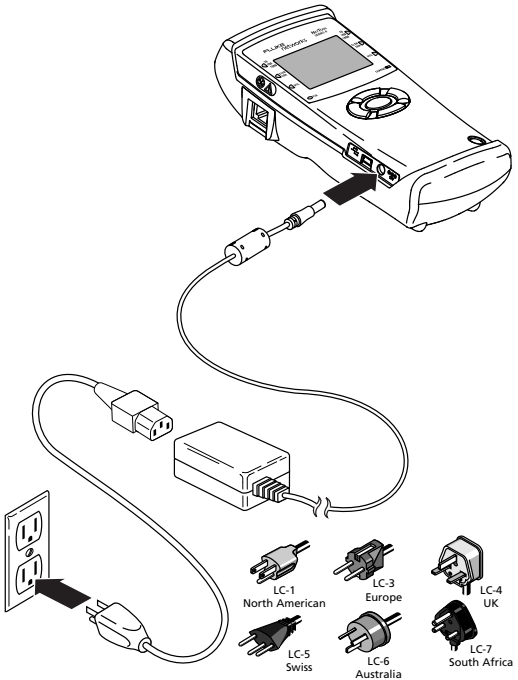

ekd02f.eps

---

## Using PoE Power

If the tester is connected to PSE and has negotiated power from the device, it uses power supplied by the PSE.

### *Note*

You must use the left RJ-45 jack to connect the tester to a PoE switch.

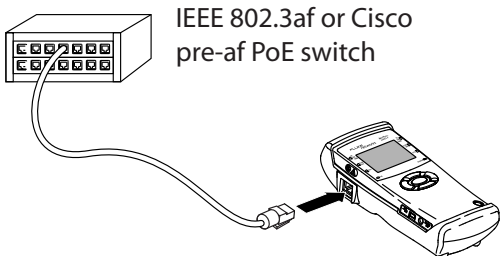

ekd03f.eps

The tester first attempts to pass PoE power through to a PD. If such a device is not attached, the tester draws power from the attached PoE switch.

The **PoE** LED lights blue to indicate that power is being drawn from the PSE or that PoE power is being drawn inline.

# Front View

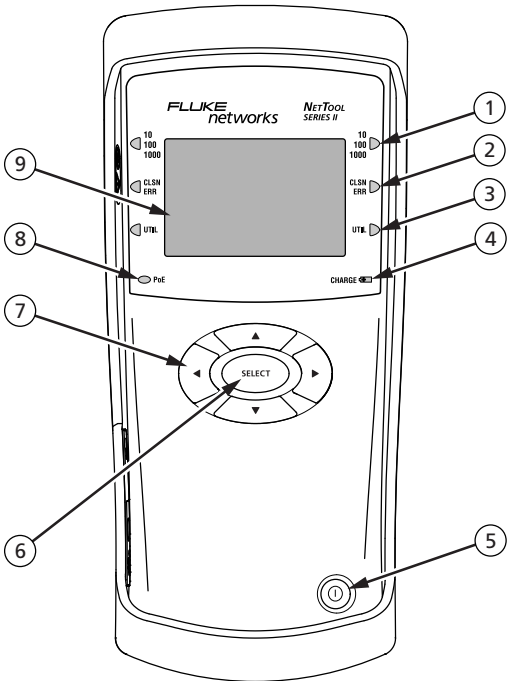

ekd04f.eps

## Front Panel Buttons and LEDs

Item Number	Function
①	<p>Link LED for the left and right RJs</p> <ul style="list-style-type: none"><li>• White: 1000 MB connection.</li><li>• Blue: 100 MB connection.</li><li>• Green: 10 MB connection.</li></ul>
②	<p>Collision/Error LED for the left and right RJs</p> <ul style="list-style-type: none"><li>• Yellow: collisions are occurring.</li><li>• Red: errors are being detected.</li></ul>
③	<p>Utilization LED for the left and right RJs</p> <ul style="list-style-type: none"><li>• Green: utilization levels are below 50 %.</li><li>• Yellow: utilization levels are between 50 % and 90 %.</li><li>• Red: utilization levels are higher than 90 %.</li></ul>

## Front Panel Buttons and LEDs (cont)

Item Number	Function
④	<b>CHARGE LED</b> <ul style="list-style-type: none"><li>• Steady green: batteries are fully charged, and the tester is using AC or PoE external power.</li><li>• Blinking green: batteries are more than 50 % full and charging.</li><li>• Blinking orange: batteries are less than 50 % full and charging.</li></ul>
⑤	Power button: press and hold to turn on the tester.
⑥	<b>SELECT</b> button: press to select a menu option.
⑦	Navigation keys: press to scroll to menu options and navigate the menu system.
⑧	<b>PoE LED</b> : Lights steady blue when the tester is connected to and drawing power from a PSE or when PoE is being detected inline.
⑨	LCD: Backlit graphical LCD displays menus, test results, and connection diagrams.

---

## Left Side View

---

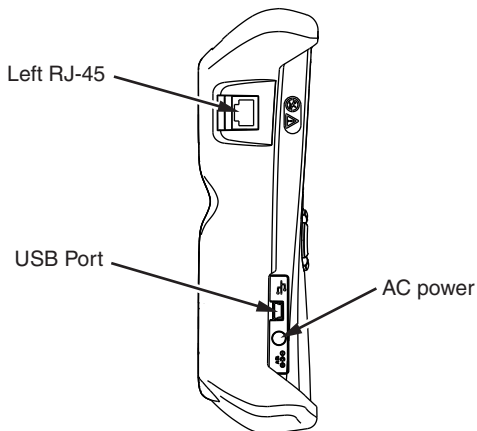

ekd05f.eps

**Left RJ-45:** Use the left RJ-45 jack for a single-ended connection (that is, when connecting the tester directly to a cable, a PC, an IP phone, wall drop, or a network device). Use both jacks only when using the built-in wiremap function or for an inline connection (that is, when connecting the tester between two devices, such as a hub and PC).

**USB:** Use to connect the tester to a PC to enable software options, to update it with the latest software, and to download PING catalogs, reports, and screen shots.

**AC power:** Use to connect the tester to the optional AC adapter.

---

## Navigation Buttons

---

The navigation keys encircle the **SELECT** key. These keys control the on-screen cursor and enable you to navigate through the menu system.

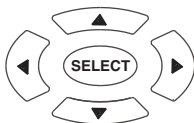

ahn310f.eps

---

### Scrolling

To scroll through a menu, press the Up ▲ and Down ▼ arrow keys. When the desired item is highlighted, press **SELECT**.

---

### Paging Up and Down

If a menu has several pages, press the Left ◀ arrow key to display the preceding page or the Right arrow key ▶ to advance to the next page.

---

### Closing the Current Screen

To close the current screen, press the Up arrow ▲ key to move the cursor to the  (located in the top right corner) and then press **SELECT**.

---

### Accessing Configuration Screens

Certain screens display the configuration icon: . Select this icon to access the configuration menu for the particular function.

## Menus

After AutoTest runs, the top-level screen is displayed:

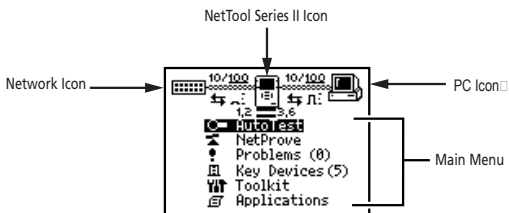

ekd06f.eps

## Network Diagram

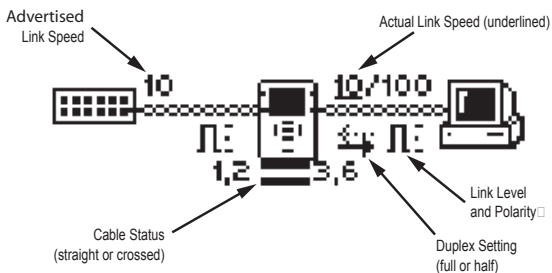

The network diagram at the top of the screen provides at-a-glance information about the connection.



ekd07f.eps













The icons represent the connected devices:

- The NetTool icon  is located in the center of the diagram. Select this icon to access the tester's configuration screens.
- The Network  and PC  icons appear to the left or right of the NetTool icon, depending on how you connected the cable. You can select these icons to drill down and obtain detailed information about the device and/or network.

The network symbols provide link and cabling information, as described in the following table.

### Legend for the Network Diagram

 Connected device (PC, printer, IP phone)	 Normal level, normal polarity
 NetTool tester	 Normal level, reverse polarity
 Network	 Low level, normal polarity
 Full duplex  Half duplex	 Low level, reverse polarity.
 Straight cable  Crossed cable	<b>AUTO-M</b> Automatic MDI-X connection

---

## Main Menu

The Main menu is located under the connection diagram. From this menu, you can select the following:

- **AutoTest:** automatically analyzes the connection at the RJ-45 jacks and displays results.
- **NetProve:** automatically proves Ping and Application connectivity to servers and key devices. Indicates pass/fail based on ping and TCP port response times.
- **Problems:** displays the Problem log, which alerts you to problems detected, such as errors, duplex mismatches, and duplicate IP addresses.
- **Key Devices:** displays all key devices and categorizes them by type (for example, servers, routers, printers).
- **Toolkit:** contains a group of support tools, such as Health, Protocols, Ping, and Reporter that help you troubleshoot and document your network.
- **Applications:** contains additional applications (if installed), such as VoIP and Security (802.1X, Port Monitor, etc.).

---

## Setting User Preferences

---

You may need to change some of the default configuration settings so that your tester fits your particular work environment and testing situations.

From the **Main** menu:

1. Select the NetTool icon  to access the **NetTool** menu.
2. Select **Settings** to view these options:
  - **Feet/Meters:** select the desired unit of measurement for tests.
  - **Power Auto Off:** select to turn the tester off after 10 minutes of inactivity.
  - **PoE Enabled:** select to turn this option on or off.
  - **NiMH Charging Enabled:** select to enable charging of NiMH batteries (when installed).
  - **802.1X Enabled:** select to turn this option on or off.
  - **Set Time/Set Date:** Press ▲ ▼ to change a number; press ◀ ▶ to move the cursor to the next position. After the desired time/date is displayed, press **SELECT** to save.
  - **Restore Defaults:** press **SELECT** to restore all of the tester's factory default settings. Deletes user data.

---

## Connecting the Tester

---

The tester has two RJ-45 jacks, one on each side. For a single-ended connection, plug one end of a cable into the left jack and the other end directly into a wall plate to check a network drop or into a device such as PC, hub, or switch.

For an inline connection, use both jacks to plug the tester between two devices, such as a hub and a PC. Plug the left RJ into the switch and the right RJ into the PC or client device.

---

### Single-Ended Connections

For a single-ended connection, connect the device-under-test to the tester's left RJ-45 jack.

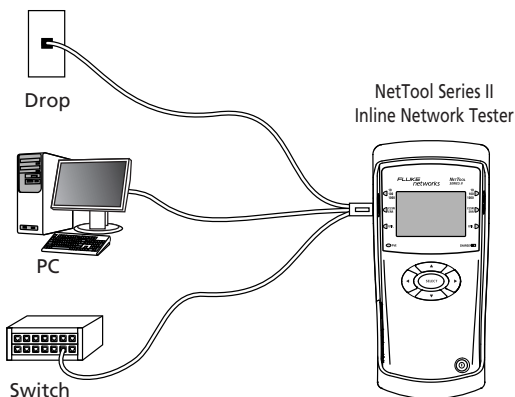

ekd08f.eps

---

## Patch Cable Test

---

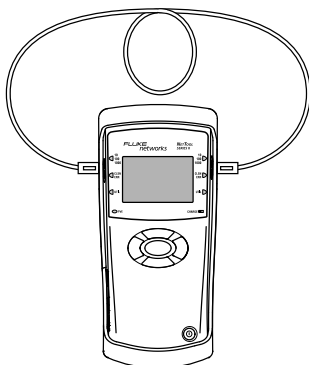

ekd09f.eps

---

## Wiremap

---

When both ends of a cable cannot be connected to the tester (for example, if one end is in a wiring closet), connect a wiremap adapter to the far end:

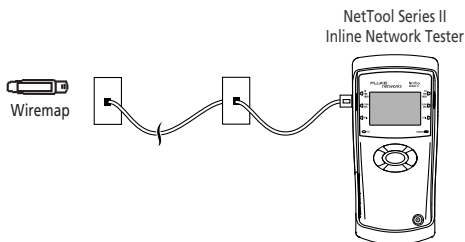

ekd10f.eps

## Note

To access the **Toner** menu, click  (the NetTool icon).

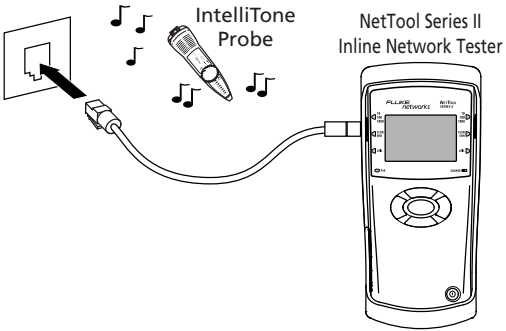

ekd11f.eps

## Inline Connection

### Note

*Use the left RJ to connect the tester to the network and the right RJ to connect to a PC or phone.*

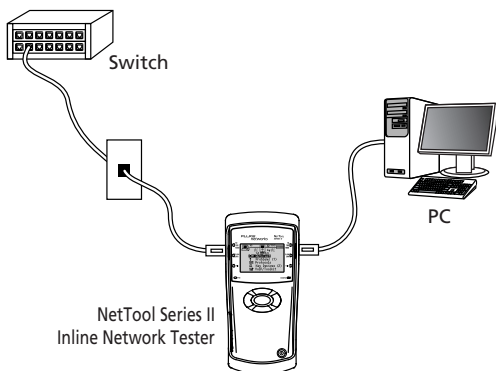

ekd12f.eps

---

## AutoTest

---

When you run AutoTest, the tester searches the RJ-45 connections to determine what it is connected to and then displays results.

To run AutoTest:

1. Connect the NetTool tester as shown in one of the network diagrams presented earlier.
2. Turn on the tester.

The **AutoTest** screen is displayed:



ahn13s.bmp

3. If a device is connected, turn it on.
4. Press **SELECT** to start AutoTest.



---

## Cable Test Results

After AutoTest ends, select the Spool icon . Then, press **SELECT**.

The **Cable** screen displays the length of the cable and indicates whether any opens, shorts, or split pairs are detected.

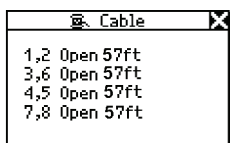

afq32s.bmp

---

## Wiremap Test Results

After AutoTest ends, select the Wiremap icon . Then press **SELECT**.

Cable length and pin configurations are displayed, enabling you to verify that individual wires are properly connected and that no opens or shorts are present:

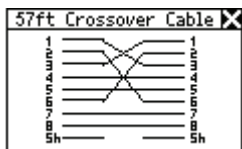



afq34s.bmp

---

## Service Identification Test Results

After AutoTest ends, the tester displays the type of service that is active on the jack:

-  **Telco**
- **Ethernet**
-  **No Response:** the tester detects the device but the device is not responding

---

## Device and Network Test Results

After AutoTest completes, select the PC icon  to find out about the PC device:

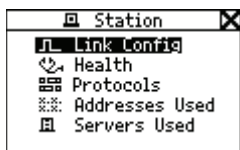

afq16s.bmp

From the **Station** menu, you can obtain critical information that can help you verify whether the device is configured correctly and can communicate properly with the network.

Select the Network icon  to obtain information about the network:

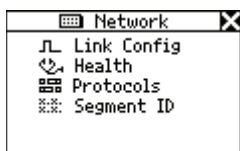

ahn200s.bmp

This **Network** menu provides details about the link and information about the health of frames. You can use this information to troubleshoot network-related problems.

---

## *NetTool Connect*

---

NetTool Connect is a software utility that is located on the CD-ROM that is packaged with NetTool. This program enables you to do the following:

- Install software updates on your NetTool tester
- Download the tester's screen captures to your PC
- Download, edit, store, and upload NetProve catalogs
- Download option key information (VoIP, 802.1X, Port Monitor, etc.)
- Manage/download 802.1X authentication setup (only one authentication setup/certificate can be downloaded to a NetTool Series II at a time)
- Manage/download Port Monitor port selection information
- Generate HTML or PDF reports from either live or saved test data

Install NetTool Connect. Then, select **Help** for instructions on how to use the program.

---

## *Updating the Software*

---

From time to time, updates to NetTool software are released. To determine what version is currently installed on your tester:

1. Select the NetTool icon  .
2. Select **About NetTool..**

To find out whether a more recent software version is available, go to [www.flukenetworks.com](http://www.flukenetworks.com). Find the NetTool product and then click the software link.

If a newer software version is listed, follow the instructions to download the file to your PC. Use the supplied USB cable to connect the tester to your PC.

## Note

To transfer software update files to your tester, you must have NetTool Connect installed on your PC. You can find this software on the CD that came with your purchase.

---

## Contacting Fluke Networks

---



[www.flukenetworks.com](http://www.flukenetworks.com)



[support@flukenetworks.com](mailto:support@flukenetworks.com)



+1-425-446-4519

- Australia: 61 (2) 8850-3333 or 61(3) 9329 0244
- Beijing: 86 (10) 6512-3435
- Brazil: 11 3044 1277
- Canada: 1-800-363-5853
- Europe: +44-(0) 1923 281 300
- Hong Kong: 852 2721-3228
- Japan: 03-3434-0510
- Korea: 82 2 539-6311
- Singapore: 65 6799-5566
- Taiwan: (886) 2-227-83199
- USA: 1-800-283-5853
- Anywhere in the world: +1-425-446-4519

Visit our website for a complete list of phone numbers.