

The logo for Tequipment.NET, featuring a large red "T" on the left. To its right is a small American flag with the word "USA" in blue above it. Below the "T" and "USA" is the word "equipment" in blue, and ".NET" in red. A blue line connects the bottom of the "T" to the ".NET".

205 Westwood Ave  
Long Branch, NJ 07740  
1-877-742-TEST (8378)  
Fax: (732) 222-7088  
salesteam@Tequipment.NET

# MetroScope™

Service Provider Assistant

## Getting Started Guide

PN 3001493

July 2007

©2007 Fluke Corporation. All rights reserved. Printed in USA.  
All product names are trademarks of their respective companies.

## LIMITED WARRANTY AND LIMITATION OF LIABILITY

Each Fluke Networks product is warranted to be free from defects in material and workmanship under normal use and service. The warranty period for the mainframe is one year and begins on the date of purchase. Parts, accessories, product repairs and services are warranted for 90 days, unless otherwise stated. Ni-Cad, Ni-MH and Li-Ion batteries, cables or other peripherals are all considered parts or accessories. The warranty extends only to the original buyer or end user customer of a Fluke Networks authorized reseller, and does not apply to any product which, in Fluke Networks' opinion, has been misused, abused, altered, neglected, contaminated, or damaged by accident or abnormal conditions of operation or handling. Fluke Networks warrants that software will operate substantially in accordance with its functional specifications for 90 days and that it has been properly recorded on non-defective media. Fluke Networks does not warrant that software will be error free or operate without interruption.

Fluke Networks authorized resellers shall extend this warranty on new and unused products to end-user customers only but have no authority to extend a greater or different warranty on behalf of Fluke Networks. Warranty support is available only if product is purchased through a Fluke Networks authorized sales outlet or Buyer has paid the applicable international price. Fluke Networks reserves the right to invoice Buyer for importation costs of repair/replacement parts when product purchased in one country is submitted for repair in another country.

Fluke Networks warranty obligation is limited, at Fluke Networks option, to refund of the purchase price, free of charge repair, or replacement of a defective product which is returned to a Fluke Networks authorized service center within the warranty period.

To obtain warranty service, contact your nearest Fluke Networks authorized service center to obtain return authorization information, then send the product to that service center, with a description of the difficulty, postage and insurance prepaid (FOB destination). Fluke Networks assumes no risk for damage in transit. Following warranty repair, the product will be returned to Buyer, transportation prepaid (FOB destination). If Fluke Networks determines that failure was caused by neglect, misuse, contamination, alteration, accident or abnormal condition of operation or handling, or normal wear and tear of mechanical components, Fluke Networks will provide an estimate of repair costs and obtain authorization before commencing the work. Following repair, the product will be returned to the Buyer transportation prepaid and the Buyer will be billed for the repair and return transportation charges (FOB Shipping point).

**THIS WARRANTY IS BUYER'S SOLE AND EXCLUSIVE REMEDY AND IS IN LIEU OF ALL OTHER WARRANTIES, EXPRESS OR IMPLIED, INCLUDING BUT NOT LIMITED TO ANY IMPLIED WARRANTY OR MERCHANTABILITY OR FITNESS FOR A PARTICULAR PURPOSE. FLUKE NETWORKS SHALL NOT BE LIABLE FOR ANY SPECIAL, INDIRECT, INCIDENTAL OR CONSEQUENTIAL DAMAGES OR LOSSES, INCLUDING LOSS OF DATA, ARISING FROM ANY CAUSE OR THEORY.**

Since some countries or states do not allow limitation of the term of an implied warranty, or exclusion or limitation of incidental or consequential damages, the limitations and exclusions of this warranty may not apply to every buyer. If any provision of this Warranty is held invalid or unenforceable by a court or other decision-maker of competent jurisdiction, such holding will not affect the validity or enforceability of any other provision.

4/04

Fluke Networks  
PO Box 777  
Everett, WA 98206-0777  
USA

# Table of Contents

Title	Page
About This Guide .....	1
Introduction .....	1
Features .....	2
Registering Your Instrument .....	9
Care and Maintenance .....	10
Contacting Fluke Networks .....	10
Before You Begin .....	11
Turning the Instrument On and Off .....	11
Using the Stylus .....	12
Updating the Software .....	12
Changing the Help and User Interface Language .....	14
Adjusting the Brightness of the Screen .....	15
Setting the Time and Date .....	16
Recalibrating the Screen .....	16
The Power Supply .....	17
Operating the Instrument on Battery Power .....	17
Operating the Instrument on External Power .....	19
Physical Features .....	21

# MetroScope Service Provider Assistant

## Users Manual

---

Network Connections .....	21
External Interfaces .....	22
External Power Connection .....	22
Status LEDs .....	24
Power LED .....	26
The User Interface .....	26
Screen Layout .....	26
Navigating the User Interface .....	30
Personalizing Your Instrument .....	30
Getting Help .....	31
Accessing the Documentation on CD .....	32
Monitoring a Wired LAN .....	33
Connecting to the Network .....	34
Viewing AutoTest Results .....	35
Monitoring a Fiber LAN .....	36
Installing and Removing an SFP Fiber Adapter .....	37
Connecting a Fiber Cable to the Network .....	39
Configuring the Instrument .....	40
TCP/IP Settings .....	41
802.1Q/IP TOS Settings .....	42
Connection Log .....	44
Ethernet Settings .....	44
Instrument Security Settings .....	45
General Settings .....	46
Reports .....	48
Creating a Report .....	49
Managing Reports .....	50
Running the Diagnostic Tests .....	53

---

Accessing the Instrument Remotely ..... 54  
User Interface Events That Terminate a Remote Session ..... 57  
Using the Desktop Tools ..... 57  
    Applications Menu ..... 57  
    Tools Menu ..... 59  
Troubleshooting Your Instrument ..... 60  
Specifications ..... 64  
Index ..... 69

**MetroScope Service Provider Assistant**  
Users Manual

---

# List of Tables

<b>Table</b>		<b>Page</b>
1	List of Standard Accessories.....	1-4
2	Optional Accessories .....	1-6
3	International Electrical Symbols .....	1-7

**MetroScope Service Provider Assistant**  
Users Manual

---



# List of Figures

<b>Figure</b>		<b>Page</b>
1	Charging and Removing the Battery .....	1-20
2	MetroScope Service Provider Assistant's Physical Features.....	1-23
3	Status LEDs.....	1-24
4	Screen-Level Help .....	1-31
5	Test Results Screen .....	1-35
6	Inserting the Fiber Adapter .....	1-38
7	Instrument Settings—TCP/IP Screen .....	1-41
8	Instrument Settings—Security Screen .....	1-45
9	Web Server Home Page .....	1-55



# MetroScope™

## Service Provider Assistant

### About This Guide

This *MetroScope™ Service Provider Assistant Getting Started Guide* introduces you to the features and functions of your MetroScope Service Provider Assistant and provides basic instructions for setting up and operating the instrument. The information in this guide is designed to help you become comfortable using your new product. After reading this guide, you will find the online help system the best source for assistance with using MetroScope Service Provider Assistant to diagnose and troubleshoot performance issues as they arise.

### Introduction

MetroScope Service Provider Assistant (also referred to as “the instrument”) is a portable, integrated network test tool designed to assist you with commissioning and troubleshooting Carrier and Metropolitan Ethernet services that carry voice, data, and video. The MetroScope Service Provider Assistant provides an integrated solution to help you with every phase of the deployment cycle from physical layer verification of fiber cables, to SLA validation and reporting, and dispute resolution. You’ll get instant visibility into your network and obtain crucial information about its health and status so that you can proactively identify and solve problems before they impact performance.

## MetroScope™ Service Provider Assistant Getting Started Guide

---

### Features

With MetroScope Service Provider Assistant, you can:

- Provision equipment and test physical media to verify copper cabling or qualify dark fiber for deployment.
- Turn up, validate, and document new Ethernet and IP services for SLA conformance.
- Test IP connectivity and validate networks for throughput, loss, latency, and burstability.
- Measure jitter to certify a network's readiness for VoIP and IPTV.

- Generate Layer 2 and 3 background traffic to load and stress links.
- Perform active and passive monitoring of live traffic. Uncover congestion points and bottlenecks on a link.
- Effectively monitor networks remotely from any location for escalation, training, and 24/7 access.

The autotest feature provides rapid diagnostics and troubleshooting. For in-depth analysis, the instrument also includes traditional diagnostic tools (Ping and Trace Route) as well as Trace Switch Route, which displays switch/port information and provisioning of the route, and Server Response Tool (SRT), which enables you to test application server connectivity and responsiveness.

A report feature enables you to document the environment and performance. XML reports can be generated and viewed locally or saved and viewed remotely via the built-in web server. A notes facility enables you to add on-the-spot comments to a report.

The instrument's user interface, which is presented in color on a touch-sensitive screen, is straightforward and intuitive. Simply by tapping a screen button, a navigation icon, or other on-screen element, you can "drill down" and obtain more detailed information or perform a specific operation.

### **Package Contents**

Take a moment to check the shipping container to make sure that the contents match each standard accessory that is listed in Table 1 on page 4.

If any item is damaged, call the carrier at once for inspection and request an inspection report. Please do not write the factory until you have notified the carrier because this will delay your claim. If this precaution is not taken, we cannot assist you with recovering the amount of the claim against the carrier.

After you obtain the carrier's inspection report, immediately return the instrument along with a copy of the inspection report to the factory. For various ways to contact us, see "Contacting Fluke Networks" on page 10.

**Table 1. List of Standard Accessories**

Item	Description
MetroScope Service Provider Assistant	MetroScope Service Provider Assistant mainframe.
Stylus	Stylus for use with the instrument's touchscreen display.
Softcase	Case for carrying and storing the instrument.
Carrying Strap	Strap clips to the instrument for easy carrying.
External AC Adapter Charger; Power Cord	Input: 90V -264V AC, 50/60Hz; Output: 15V DC, 1.3A (20W); power cord termination varies by country.
Network Patch Cord	1 meter patch cord.
Universal Adapter	RJ-45 female-to-female adapter. Used to connect an RJ-45 Ethernet cable from the instrument to a Wireview™ Wiremap adapter.

**Table 1. List of Standard Accessories (continued)**

<b>Item</b>	<b>Description</b>
Wireview™ Wiremapper #1	Cable termination device with office locator ID #1. Used to perform Cable Test wiremap operation and used as an office locator.
CompactFlash® memory card	CompactFlash® memory card used for saving reports.
Battery Pack	Rechargeable Lithium Ion battery pack installed in the instrument.
CD-ROM	MetroScope Resource CD. Includes online Help and Getting Started Guides.
Getting Started Guide	Provides basic operating and introductory troubleshooting information, lists of accessories, and specifications.

## MetroScope™ Service Provider Assistant Getting Started Guide

---

### Optional Accessories

Additional accessories that you can purchase for your MetroScope Service Provider Assistant are listed in Table 2. Contact Fluke Networks for buying information (see “Contacting Fluke Networks” on page 10).

**Table 2. Optional Accessories**









<b>Accessory</b>
1000BASE-SX Fiber SFP Transceiver (850 nm VCSEL)
1000BASE-LX Fiber SFP Transceiver (1310 nm FP laser)
1000BASE-ZX Fiber SFP Transceiver (1550 nm FP laser)
100BASE-FX Fiber SFP Transceiver (850 nm VCSEL laser)
External Battery Charger
Auto Lighter Charger
Replacement Battery
Mini USB Keyboard
AC Charger (universal)
Null Modem Cable (DB9)



## Safety and Operational Information

The international electrical symbols used in this document and on the instrument are described in Table 3.

**Table 3. International Electrical Symbols**

	Not for connection to public telephone systems		Complies to CSA C22.2 No. 950 Canadian standards, and UL 1950 (US standards)
	Please read the manual for safety information		Do not dispose of Lithium Ion batteries in garbage, recycle
	Complies with European Union Directive		Meets Australia EMC requirements
	Shock hazard		Recycle Lithium Ion batteries
	Class 1 Laser Product. Do not look into the laser.		

## MetroScope™ Service Provider Assistant Getting Started Guide

---

Please observe the following safety regulations when using your MetroScope Service Provider Assistant:

### **Warning Class 1 Laser Product**

This product contains a Class 1 laser. Do not look into the laser port because this may cause eye injury.

### **Warning**

To avoid possible electric shock or personal injury, follow these guidelines:

- Do not use this product if it is damaged. Before using the product, inspect the case. Look for cracked or missing plastic.
- Do not operate the product around explosive gas, vapor, or dust.
- Do not open the case. There are no user-serviceable parts inside.

- Do not connect a telephone line to this product.
- If this product is used in a manner not specified by the manufacturer, the protection provided by the product may be impaired.

### **Caution**

To avoid possible damage to the instrument and to the equipment under test, use the proper terminals and cable for all connections.

Use of controls or adjustments or performance of procedures other than those specified herein may result in hazardous radiation exposure.

## Registering Your Instrument

Take the time to register your instrument. The MetroScope Resource CD contains registration information and instructions.

You can also register the instrument by going to our website at [www.flukenetworks.com](http://www.flukenetworks.com). To register, do the following:

- If you are a registered user, click the **MyAccount Sign In** link. Supply your email address and password and then click **Sign In**.
- If you need to set up an account, click the **Create an Account** link. Supply the required information and then click **Submit**.

As a registered user, you are entitled to entry-level product support. This includes basic access to the online Knowledge Base library of product operation and application information and web-based trouble ticketing. In addition, you will receive Fluke Networks company and product information updates.

After registering the product, make sure that you have the latest software installed. See "Updating the Software" on page 12 for details.

## MetroScope™ Service Provider Assistant Getting Started Guide

---

### Care and Maintenance

To obtain reliable test results, always follow proper cleaning and maintenance procedures:

- To prevent moisture from entering the instrument, clean the touchscreen with a moist cloth only.
- Do not spray water directly on the touchscreen. Wipe the case with a damp cloth.
- Do not use organic solvents, acid, or alkali solutions.

### Contacting Fluke Networks

To order accessories or to find out the location of the nearest Fluke Networks distributor or service center, contact us using any one of the following methods:

 [www.flukenetworks.com](http://www.flukenetworks.com)

 [support@flukenetworks.com](mailto:support@flukenetworks.com)

 +1-425-446-4519

- Australia: 61 (2) 8850-3333 or 61 (3) 9329 0244
- Beijing: 86 (10) 6512-3435
- Brazil: 11 3044 1277
- Canada: 1-800-363-5853
- Europe: +44 -(0)1923 281 300
- Hong Kong: 852 2721-3228
- Japan: 03-3434-0510
- Korea: 82 2 539-6311
- Singapore: +65-6799-5566
- Taiwan: (886) 2-227-83199
- USA: 1-800-283-5853

Visit our website for a complete list of phone numbers.

## Before You Begin

The information in this section acquaints you with the basic operations and functions of your instrument so that you can start using it immediately. You will learn how to:

- Turn on the instrument.
- Update the instrument's software.
- Change the language for Help and the user interface.
- Adjust the brightness of the screen.
- Set the date and time.
- Recalibrate the screen.
- Charge the battery.
- Navigate the user interface and understand the meanings of the LEDs.
- Get Help.

## Turning the Instrument On and Off

To turn on the MetroScope Service Provider Assistant, press the green **On/Off** button. This button is located on the right side of the instrument's front panel (see Figure 3).

After you turn on the instrument, the front page **Test Results** screen is displayed (see Figure 5).

### *Note*

*When you turn on the instrument, you may hear a series of clicks. These sounds are a normal part of the boot-up and cable testing process and do not indicate a problem with the instrument.*

To turn off the instrument, press and hold the **On/Off** button until the instrument turns off (approximately two seconds). The Power LED blinks when the instrument is turned off and connected to the AC adapter charger, indicating that the battery is charging.

### Using the Stylus

The supplied stylus, which is used for navigating the user interface, is stored in the right side panel near the green **On/Off** button (see Figure 2).

In the same way that you use a mouse to click elements on your computer screen, you use the stylus to “tap” elements on the instrument’s touch-sensitive screen.

To select an option or run a command, simply tap the item with the point of the stylus. In addition, use the stylus to drag a slider or to move the scroll box on the scroll bar.

#### Note

*Always use the point of the stylus to tap the screen. We do not recommend that you use a pen or pencil or any other sharp object that might scratch the finish. Also, avoid using a finger to avoid getting the natural oil from your hand on the screen.*

### Updating the Software

To get the latest features for your instrument, you need to make sure that you have the current version of software installed.

#### Check for Updates

- 1 Tap the MetroScope Master Menu icon , which is located in the upper-left corner of the screen.
- 2 From the drop-down list, select **Instrument Settings**.
- 3 In the preview pane, tap **Version**.

The **Instrument Settings—Version** screen displays the versions of currently installed software and hardware.

- 4 To check for updates, make sure that the instrument is connected to the Internet and then tap **Check for software updates**.



The instrument automatically checks to determine whether a software update is available.

## Install the Software

To update the instrument's software, complete the following:

### Caution

**Previously loaded software on the CompactFlash memory card will be erased.**

- 1 Insert a CompactFlash memory card into **SLOT 2** (see Figure 2).
- 2 When prompted, tap  to download the update files to the CompactFlash memory card.
- 3 After you are notified that the download is completed, tap .

- 4 With the CompactFlash card in **SLOT 2**, restart the instrument to begin installing the software.

#### Note

*A software update can take up to ten minutes.*

After installation is completed, the instrument automatically restarts. You can resume testing.

If you have trouble updating the software, contact our Technical Assistance Center (see "Contacting Fluke Networks" on page 10).

## Update the Language File

The CompactFlash memory card contains updated language files for Help and the user interface. To update the instrument with the new language files, you need to transfer those files to the instrument. Follow the instructions under the "Language Settings" topic in the online Help.

### Changing the Help and User Interface Language

MetroScope Service Provider Assistant features multi-language support. Localized menus and online Help are available in the following languages:

- English
- French
- Spanish
- Portuguese
- Russian
- German
- Japanese
- Simplified Chinese

To determine whether language support is available on your instrument, do the following:



- 1 Tap the MetroScope Master Menu icon , which is located in the upper-left corner of the title bar.
- 2 From the drop-down list, tap **Instrument Settings**.

The **Instrument Settings —TCP/IP** screen (Figure 7) is displayed.

- 3 Tap the **Version** hyperlink in the left pane.

If the **Language Support** field has an extended notation as part of the version, a localized User Interface and online Help are available on your instrument.



- 4 To change the language setting:
  - a Tap the desktop icon , which is located in the bottom-left corner of the screen.
  - b Select  **Settings**.
  - c Select  **Language**.





The list of available languages is displayed.
  - d Select the desired language.
  - e Tap .
- 5 Restart the instrument to enable the language setting to take effect.

## Adjusting the Brightness of the Screen

### Note

*The degree of brightness is a significant factor in conserving battery power. Turning up the brightness causes the instrument to use more battery power.*

To adjust the brightness:

- 1 Tap  and then select  **Settings**.
- 2 Tap  **Light & Power**.
- 3 On the **Light and Power** screen, you can do the following:
  - Select the desired **Power saving** setting. To do this, tap (to check) an option. Then, for each option, specify a time interval.
  - Adjust the brightness. To do this, drag the slider control until the desired level of brightness is achieved.
- 4 Click  to save the settings.

### Setting the Time and Date

The current time is displayed in the bottom-right corner of the status bar. To change the time and date, do the following:



- 1 Tap the current time.
- 2 Select **Set time...** to display the **Date/Time** screen.
- 3 Select the desired time and date and formats.
- 4 Tap  to save your changes.

The new time is displayed on the status bar.

### Recalibrating the Screen

The touch-sensitive screen is calibrated at the factory. Though unlikely, the instrument may not respond appropriately when you tap the screen with the stylus. If this happens, you may need to recalibrate the screen. Recalibrating aligns the instrument's internal circuitry with the screen so that it can correctly detect taps with the stylus.

To recalibrate your screen:

- 1 Tap the desktop icon .
- 2 Select  **Settings**.
- 3 Tap  **Recalibrate**.
- 4 Follow the prompts to complete the calibration.

## The Power Supply

You can operate the instrument by using the rechargeable Lithium-Ion battery. Alternatively, you can use the supplied AC adapter charger (with or without the battery installed).

### Note

*Although the instrument can run on the AC adapter without the battery pack installed, this method is not recommended. The battery pack provides stability for the instrument when you are using the stand.*

## Operating the Instrument on Battery Power

The instrument comes packaged with the battery installed. To operate on battery power, simply turn on the instrument.

When the instrument is running on battery power, it is capable of approximately four full hours of operation. Although the battery is pre-charged at the factory, you should fully charge it before you begin using the instrument. This is an important step because if the power source is interrupted while you are operating the instrument, you will lose data.

## Charging the Battery

Figure 1 shows you how to charge the battery using the AC adapter charger or auto charger. Note that you can charge the battery while it is installed or you can remove it and charge it in an external battery charger.

### Notes

*The Power LED blinks when the instrument is turned off and connected to the AC adapter charger.*

*You can optionally purchase an extra battery and/or charger.*

When fully discharged, the battery takes approximately 4 1/2 hours to reach a full charge if the instrument is powered off. It takes approximately 7 hours to fully charge the battery if the instrument is powered on.

## MetroScope™ Service Provider Assistant Getting Started Guide



---

### Checking the Status of the Battery Charge

To find out how much battery power remains, tap the battery icon  which is located in the bottom-right corner of every screen.

### Conserving Battery Power

One way to conserve battery power is to put the instrument in standby mode. This is a low-power usage mode, in which the instrument is not completely turned on or off. While in standby mode, the instrument cannot collect data.

- To put the instrument in standby mode:
  - Tap  and then select  **Suspend**.

OR

- Press the green **On/Off** button for less than one second.

The Power LED turns amber, and the screen turns blank.

- To take the instrument out of standby mode, press the **On/Off** button. Release this button as soon as the Power LED turns green.

The screen that was displayed before you put the instrument in standby mode is redisplayed.

#### *Note*

*Another way to save battery power is to use a lower backlight setting. See “Adjusting the Brightness of the Screen” on page 15 for details.*

### Removing and Installing the Battery

The battery is located behind the product stand.

To remove the battery, refer to Figure 1 and do the following:

- 1 Make sure that the instrument is turned off.
- 2 Pull the stand up.

- 3 Push the release tab away from the battery.
- 4 Pull up on the end of the battery that is closer to the release tab to disengage the connections. Then, lift the battery out of the compartment.

To install the battery:

- 1 Insert the battery into the battery compartment.
- 2 Press on the battery near the release tab until it locks into place.
- 3 Push the release tab toward the battery to secure its position.

## Operating the Instrument on External Power

When the instrument is connected to AC power, you can use the power supply as a continuous power source. In this way, you can test for long periods of time without depleting the battery.

To operate the instrument using AC power, refer to Figure 1 and do the following:

- 1 Connect the power cord to the external AC adapter charger.
- 2 Connect the AC adapter charger to the power jack on the instrument's side panel.
- 3 Turn on the instrument.

You can also power the instrument and charge it at the same time with the (optional) auto lighter charger. Plug one end of the auto lighter charger (Figure 1) into the instrument and the other end into a vehicle power outlet.

# MetroScope™ Service Provider Assistant Getting Started Guide

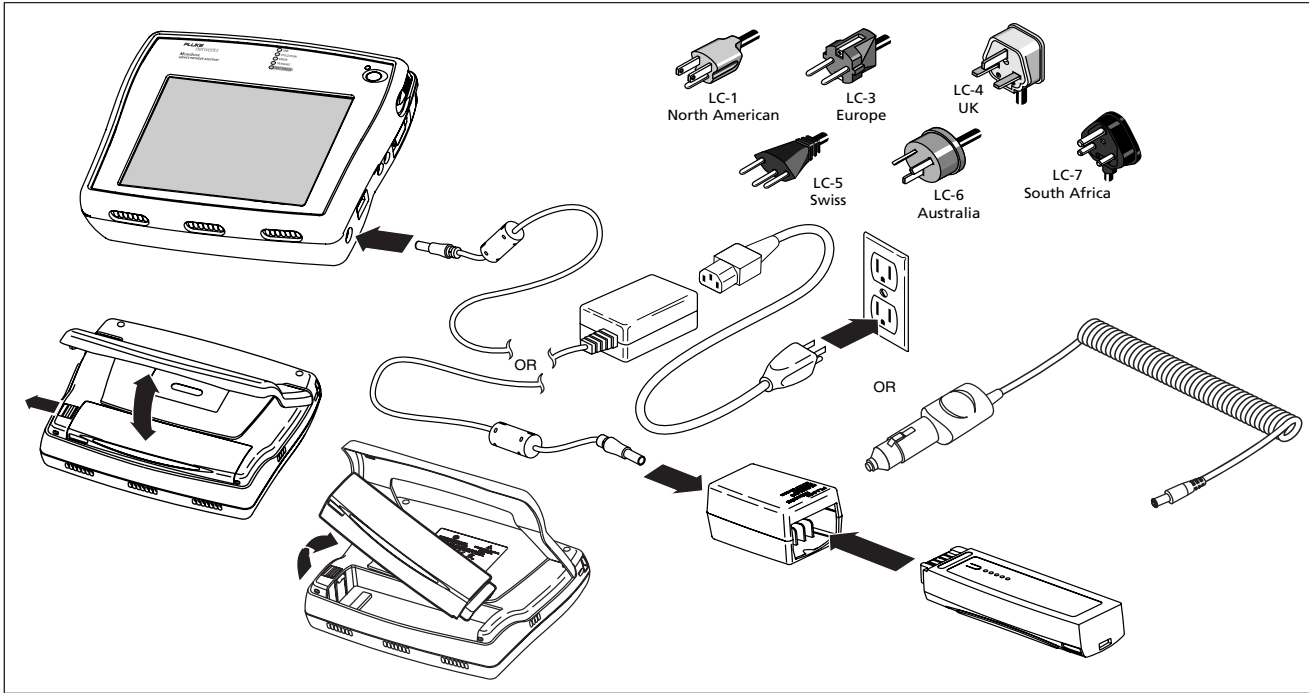

Figure 1. Charging and Removing the Battery

eyc102f.eps

---

## Physical Features

The MetroScope Service Provider Assistant is designed to be used as a dispatched or desktop network test device. The instrument is packaged with a stand for use on a desktop.

To use the stand, pull it out from the bottom of the instrument (see Figure 2). A stylus for navigating the user interface is stored in the right side panel near the green **On/Off** button.

Figure 2 illustrates the instrument's physical features.

## Network Connections

The network connections are located on the top side panel:

- **LAN:** an RJ-45 port that provides direct connection to IEEE 802.3 10/100/1000 BASE-TX networks.
- **1000BASE-X:** a port that provides connection to 1000BASE-SX, -LX, -ZX and 100BASE-FX networks.

### External Interfaces

The following external interfaces are located on the right side panel:

- Serial DB-9 port: provides a network device connection via a serial cable.
- Headphone jack: enables quiet operation of the instrument (for future applications).
- Microphone jack: (for future applications).
- USB port: connection for a USB keyboard.

**SLOT 1** is located on the top side panel. This interface is for future applications.

**SLOT 2** is located on the top side panel. This interface accepts a CompactFlash® (type 1 and 2) memory card. The memory card stores test data and temporarily holds files that are transferred from a PC during a software update.

### External Power Connection

The DC power jack is located on the right side panel. Plug the supplied AC adapter or the optional auto lighter adapter into this jack to provide external power to the instrument and to charge the battery.



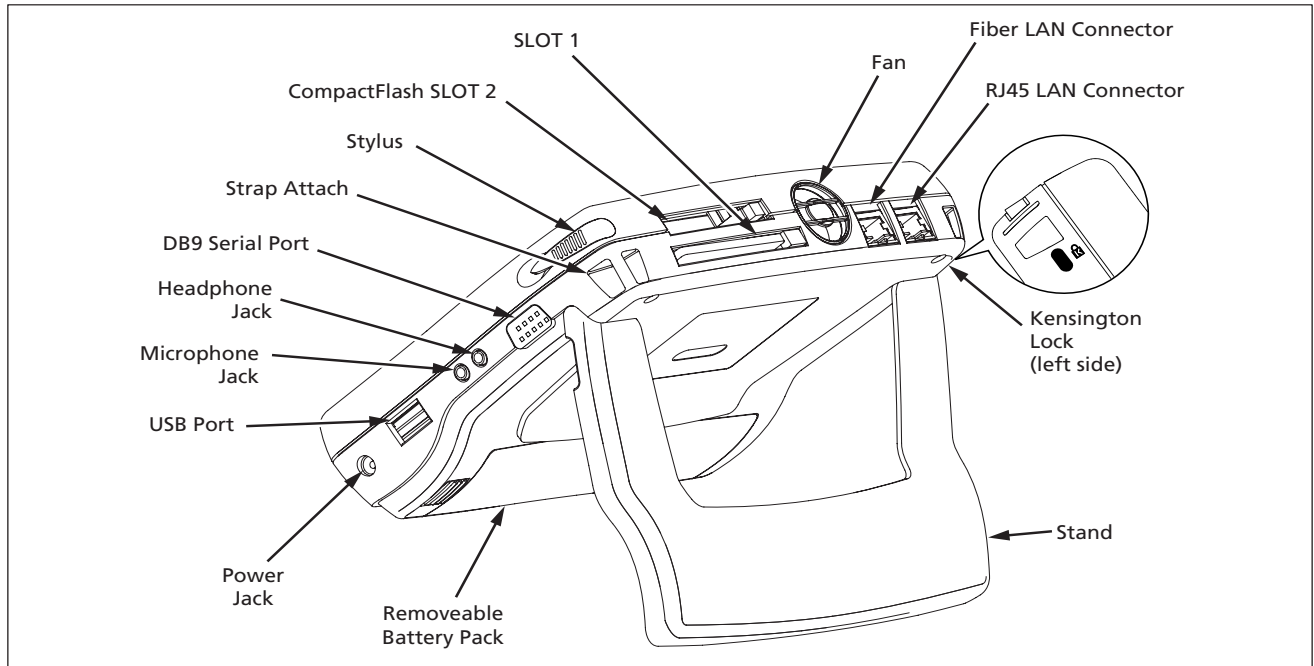

eyc106f.eps

**Figure 2. MetroScope Service Provider Assistant's Physical Features**

## Status LEDs

The status LEDs are located at the top of the front panel, as shown in Figure 3:

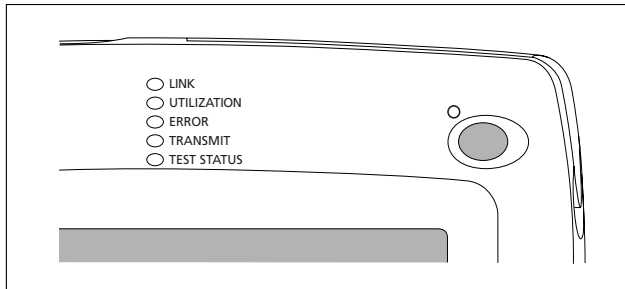

Figure 3. Status LEDs

eyc105f.eps

These LEDs provide instant, visible feedback on the state of your network relative to the type of interface you are testing.

### LINK

- Green (solid): indicates that a link is present for all speeds.
- Off: indicates that no cable or no link is present.

### UTILIZATION

Represents the percent bandwidth consumed on the local network:

- Green (blinking): 0 % to 50 %.
- Amber (blinking): 51 % to 89 %.
- Red (blinking): 90 % to 100 %.

### **ERROR**

Red (blinking): indicates that errors have been detected on the local network segment. Possible errors include the following:

- Bad FCS: a packet that has an invalid checksum.
- Undersized packet: a packet that has fewer than 64 bytes.
- Oversized packet: a packet that has more than 1518 bytes.
- Jabber: a packet that has more than 1518 bytes and also has an invalid checksum.
- Ghost: energy on a cable that appears to be a real frame; however, the frame does not have a valid start-frame delimiter.

### **TRANSMIT**

Green (blinking): indicates that the instrument is transmitting packets. Note that the more transmit activity, the faster the LED blinks.

### **TEST STATUS**

Shows the current state of the Performance Test suite, as one of the following:

- Red: the test completed and one or more tests did not pass the Pass/Fail limit.
- Green: the test completed and all tests passed the Pass/Fail limit.
- Off: the test is not running.
- Amber: the test is running.

### Power LED

- Green (solid): the instrument is turned on (same if operating on battery power or operating with the AC power adapter connected).
- Green (flashing): the instrument is turned off and the AC power adapter is connected and charging.
- Amber: the instrument is in standby mode (see “Conserving Battery Power” on page 18).
- Off: the instrument is turned off and the AC power adapter is not connected.

### The User Interface

The user interface is presented on a touch-sensitive, color screen. You navigate the user interface by tapping the touch-sensitive targets with the supplied stylus.

This section describes the layout of the user interface and describes the elements that appear on some or all of the screens. Suggestions are also provided to help you locate screens and navigate your way around.

### Screen Layout

The display screen is divided into two main areas:

- A preview pane (on the left), which provides an overview or summary of information for the item that is selected in the right (main) pane. The preview pane may also have hyperlinks (displayed in blue text) that link to other screens in the user interface.
- A main pane (on the right), which provides detailed information, such as test results, graphs, and status information.

## Title Bar

The title bar is the horizontal area at the top of every screen. The title bar shows the name of the screen that is currently displayed.

In the upper-left corner, the title bar contains the MetroScope Master Menu icon . This icon displays a menu that gives you quick access to frequently viewed screens. Select an item from this menu to go directly to that screen.

## Selection Indicator



When you select an item, it is highlighted in a contrasting color to let you know that it is selected. When you first display a screen, the default selection on that screen is always highlighted.

## Toolbar

The toolbar is the first row of buttons located at the bottom of every screen. The toolbar contains buttons and icons that are used to perform basic tasks.







### Note

*The toolbar buttons that are available depend on the test that is selected.*

- : (RJ-45 mode) reports the actual link speed and duplex mode of the connection. Two solid arrows (shown) indicate a full-duplex connection; one solid and one outlined arrow represent a half-duplex connection. An asterisk indicates a forced setting (see “Ethernet Settings” on page 44).
- : (fiber mode) reports the link speed, full duplex (always), and the SFP hardware module installed (SX, LX, ZX, or FX).

## MetroScope™ Service Provider Assistant Getting Started Guide

---



-  **Details**: displays detailed information or results for the selected test or device.
-  **Restart all**: restarts all tests.
-  (Back): displays the previously displayed screen.
-  (Home): displays **Test Results**, the top-level user interface screen.
- : displays screen-specific Help (see “Getting Help” on page 31 for details).
- : displays a menu of troubleshooting tests and productivity tools.



### Status Bar

The status bar is located at the bottom of every screen. The following icons appear on the far left:

#### Note

*All icons do not display initially. Some are displayed after you select them from the **Applications** or the **Settings** menus.*

-  Desktop icon. Tap to display a menu containing the following selections:
  -  **Applications**: displays a menu containing the instrument's desktop tools (see “Using the Desktop Tools” on page 57).
  -  **Reports**: displays a directory that lists all saved reports.

-  **Settings:** displays the **Settings** menu where you can customize your instrument's functions (see "Personalizing Your Instrument" on page 30).
-  **Suspend:** puts the instrument in standby mode (see "Conserving Battery Power" on page 18).
-  **Keyboard icon.** Tap this icon to display a virtual keyboard that you can use to enter numbers and text. Tap it again to put the keyboard away.



*Note*

*You can also use an external USB keyboard to enter information. Connect the keyboard to the instrument's USB port (shown in Figure 2).*

-  **MetroScope Service Provider Assistant icon.** Tap this icon to return to the MetroScope application.

In the bottom right corner of the status bar, the instrument displays the currently set time. For instructions on changing the date and time, see "Setting the Time and Date" on page 16.





Additional icons give you status on the following;



-  **Light & Power:** Tap this icon to view and adjust the brightness of the screen (see "Adjusting the Brightness of the Screen" on page 15).
-  **Sound:** Tap this icon to view and adjust the volume of the touchscreen's audible taps.
-  **Battery level:** Tap this icon to find out how much battery power remains. If the battery is low on power, see "Charging the Battery" on page 17.

The Clipboard icon  is also located on the bottom right. Tap this icon to display a menu with cut, copy, and paste options. These options come in handy when you are working on screens that require you to enter a lot of text.

### Navigating the User Interface

Following are some general guidelines for navigating the user interface:



- All **blue text** represents a hyperlink. Tap the hyperlink to go to the desired screen.
- To view the detailed results screen for a specific test, tap  (Home icon) to display the **Test Results** screen. In the right pane, select the desired test. Then, tap **Details** to view detailed results for your selection.
- To expand a group so that you can see individual items within it, tap . To collapse a group, tap .
- To sort data in a table, tap the desired column heading. A directional arrow indicates the column you are sorting on and the direction (ascending  or descending ) of the sort.

- Tap  (Back) to return to the previously displayed screen.
- Tap  (Home) to return to the **Test Results** screen.
- Tap  to close a screen.





### Personalizing Your Instrument

You can customize your instrument so that it suits your particular operating style and work preferences.

Tap  and then tap **Settings** to display the **Settings** menu. From this menu, you can customize the following:

-  **Appearance**  
Change the style and background color of the screen and the visual appearance of the buttons.
-  **Date/Time**  
Set the date and time and change the date/time formats.



-  **Language**  
 Change the default language (English) of Help and the user interface (see “Changing the Help and User Interface Language” on page 14).
-  **Light & Power**  
 Adjust the brightness of the screen and identify the power source (see “Adjusting the Brightness of the Screen” on page 15).
-  **Recalibrate**  
 Recalibrate the touch screen so that it can correctly detect taps from the stylus.
-  **Sound**  
 Adjust the volume of system sounds (for example, the volume level of taps on the touchscreen and the clock alarm).

## Getting Help

Screen-level Help is context-sensitive. It provides detailed “how to” and explanatory information that is related to the currently displayed screen. To view Help, tap .

MetroScope Service Provider Assistant Help is displayed, as shown in Figure 4:

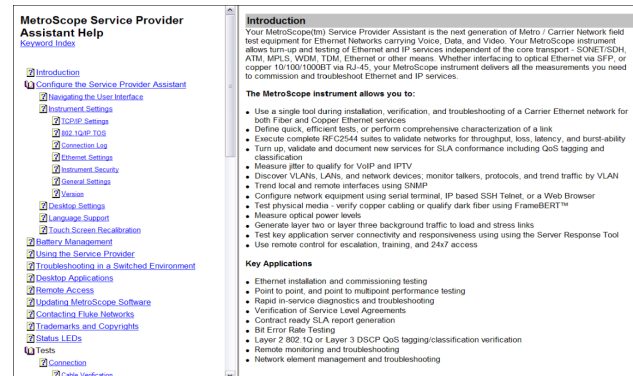

Figure 4. Screen-Level Help

eyc101s.bmp

## MetroScope™ Service Provider Assistant Getting Started Guide

---

Note that Help for the current screen is displayed in the main (right) pane.

To move the information up or down within the Help window, drag the scroll box.

The Help window is resizable and moveable so that you can view test results alongside the context-sensitive Help information. To adjust the window:

- Click the rectangular box (located in the upper right corner) to reduce the size of the window. Then, drag the bottom or right edge of the window frame to resize it.
- Drag the titlebar to move the window.

The preview (left) pane displays links for a [Table of Contents](#) and a [Keyword Index](#), which is an alphabetized list of Help topics. Select a topic from either list to view its Help.

### *Note*

*The Help file is also available on the MetroScope Resource CD.*

## Accessing the Documentation on CD

This *Getting Started Guide* is provided in PDF format on the MetroScope Resource CD. The guide is available in the following languages: English, French, Spanish, Portuguese, German, Japanese, and Simplified Chinese.

## Monitoring a Wired LAN

After you connect MetroScope Service Provider Assistant to your network and power it on, the instrument attempts to become an active device on the network by obtaining an IP address. By default, it tries to acquire an address by using DHCP.

### Note

*If your network policy requires the use of fixed IP addresses or if you need to change other network configuration data (such as the default router), see "Configuring the Instrument " on page 40.*

If the instrument acquires a valid IP address, it automatically runs a series of tests that includes verifying the cable, gathering network utilization and bandwidth statistics and actively discovering networks, services, and devices using the network. Findings are reported on the **Test Results** screen.

If the instrument cannot acquire a valid IP address, it can still analyze traffic for statistics and passively discover devices. However, without a valid IP address, the instrument cannot run its active discovery tests.

The basic steps for monitoring and troubleshooting a wired LAN are given below. Detailed information for a step can be obtained by going to the referenced section provided at each step:

- 1 Power on the instrument (see "Turning the Instrument On and Off" on page 11).
- 2 Connect to the network (see "Connecting to the Network" on page 34).

After you turn on and connect the instrument, it goes through a complete power-up sequence, which entails initializing the processor and memory, performing a self-test, and loading the operating system and application software. When this process is completed, the autotest results screen (Figure 5) is displayed.

- 3 View autotest results for each test (see “Viewing AutoTest Results” on page 35).
- 4 Make any needed configuration changes to match your testing environment (see “Configuring the Instrument “ on page 40).

### Connecting to the Network

To connect to the network, plug one end of an Ethernet cable into the instrument’s RJ-45 **LAN** connector (Figure 2) and the other end of the cable into the network segment you are testing.

#### *Note*

*If both the RJ-45 copper and SFP fiber cables are connected to the network at the same time and the instrument is trying to establish link, the fiber connection has priority over the copper connection.*

## Viewing AutoTest Results

After you power on your MetroScope Service Provider Assistant and connect to the network, the instrument runs a series of automated tests and displays its findings on the **Test Results** screen, as shown in Figure 5:

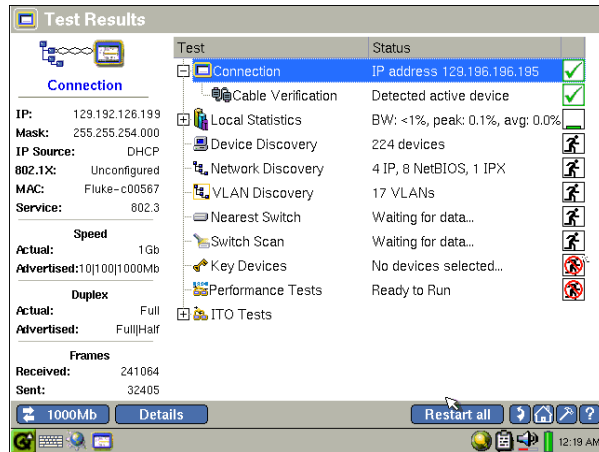





Figure 5. Test Results Screen

The **Test Results** screen gives you at-a-glance visibility into the state of your network. The main pane on the right displays the name of each test and reports its status.

Note the icons that appear along the right. They give you a visual indication of the progress and status of each test:

-  Running.
-  Not running.
-  Completed and passed.
-  Completed and failed.

epi40s.bmp

## MetroScope™ Service Provider Assistant Getting Started Guide

---

When you select a test in the right pane, the preview pane on the left provides a summary of the results.

### Note

*When autotest finishes, the **Connection** test (the default selection) is always highlighted.*

You can get quick idea of the overall health of your network and see what devices and services are running by tapping each test in the main pane and then viewing a summary of its findings in the preview pane.

To view in-depth results for any test, select the test in the main pane. Then, tap **Details**.

## Monitoring a Fiber LAN

The basic steps for monitoring a fiber LAN are listed below:

- 1 Install the SFP fiber adapter (see “Installing and Removing an SFP Fiber Adapter” on page 37).
- 2 Power on the instrument (see “Turning the Instrument On and Off” on page 11).
- 3 Connect to the network (see “Connecting a Fiber Cable to the Network” on page 39).

After you turn on and connect the instrument, it goes through a complete power-up sequence, which entails initializing the processor and memory, performing a self-test, and loading the operating system and application software. When this process is completed, the **Test Results** screen (Figure 5) is displayed.

- 4 View autotest results for each test (see “Viewing AutoTest Results” on page 35).
- 5 Make any needed configuration changes to match your testing environment (see “Configuring the Instrument ” on page 40).

## Installing and Removing an SFP Fiber Adapter

To install an SFP fiber adapter:

- 1 With the instrument turned off, remove the protective cap as shown in Figure 6.
- 2 Insert the fiber adapter, making sure that it is firmly seated into the connector.

### Warning

**SFP fiber adapters are Class 1 laser light-emitting products. Avoid staring into the SFP module while the MetroScope Service Provider Assistant is on; otherwise, injury to the eyes may occur.**

## MetroScope™ Service Provider Assistant Getting Started Guide

---

To remove the fiber adapter:

- 1 Make sure the instrument is turned off.
- 2 Press the release tab located on the back of the adapter.

### **⚠ Caution**

**Do not pull the fiber adapter without pressing the release tab or damage to the adapter may occur.**

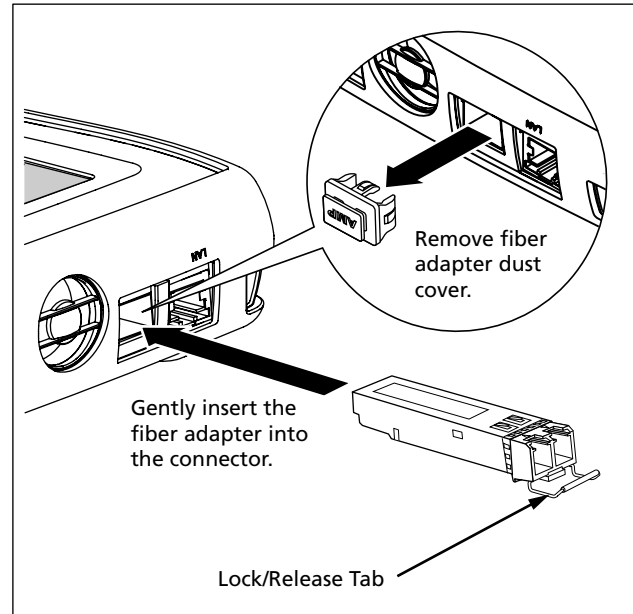

eih85f.eps

**Figure 6. Inserting the Fiber Adapter**



## Connecting a Fiber Cable to the Network

To connect to the network:

- 1 Connect one end of a fiber cable into the fiber port on the instrument.
- 2 Connect the other end of the cable into the network segment you are testing.

### Note

*Make sure that you use the correct type of fiber cable for the installed fiber adapter (optional); otherwise, you may experience no link or bad test results.*

All the existing features are supported when the instrument is connected to the fiber interface with the following exceptions:

- The link speed displays 100Mb or 1000Mb and the fiber type.
- The **Cable Verification** test is replaced with the Fiber Loss Test.

### Note

*If both the RJ-45 copper and SFP fiber cables are connected to the network at the same time and the instrument is trying to establish link, the fiber connection has priority over the copper connection.*

## Configuring the Instrument

Although MetroScope Service Provider Assistant is designed to provide as much automated configuration as possible, every network is different. For the instrument to provide you with the best network analysis possible, you may need to change some of the default configuration settings.

### *Note*

*The following procedure shows you how to access the configuration screens. For detailed descriptions of configuration settings, consult the online Help.*

To access the configuration screens, do the following:

- 1 Tap the MetroScope Master Menu icon , which is located in the upper-left corner of the title bar.
- 2 From the drop-down list, tap **Instrument Settings**.

The **Instrument Settings —TCP/IP** screen (Figure 7) is displayed.

On this screen, you can configure the instrument's TCP/IP settings.

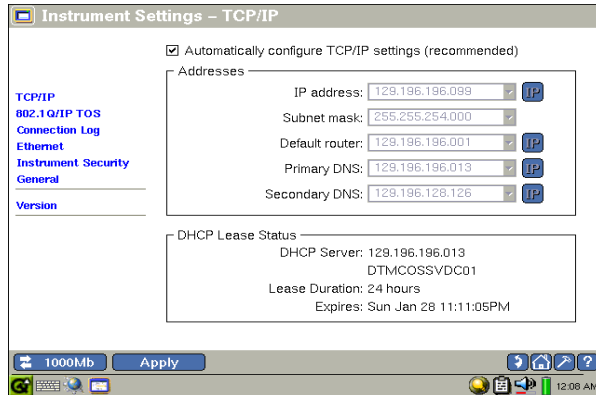

eyc100s.bmp

**Figure 7. Instrument Settings—TCP/IP Screen**

Click the hyperlinks in the preview pane to go to other **Instrument Settings** screens, which are described in sections that follow.

## TCP/IP Settings

If DHCP is available, the **Instrument Settings—TCP/IP** screen displays the address that the instrument is able to obtain.

If you want to manually configure the IP address or change the subnet mask, do the following:

### Note

*When manually assigning an IP address, you can use an address for an alternate subnet. However, that address must be in the same broadcast domain as the MetroScope Service Provider Assistant.*

- 1 Clear the **Automatically configure TCP/IP settings** checkbox to disable auto-configuration of the IP settings.

## MetroScope™ Service Provider Assistant Getting Started Guide

---

- 2 For the address field that you want to change, do the following:
  - Tap **IP** and use the keyboard to supply an IP address.
  - OR
  - Select an address from the drop-down list.
- 3 Tap **Apply** to save your changes.

### 802.1Q/IP TOS Settings

The 802.1Q/IP TOS settings define the VLAN tag in the header of an Ethernet packet. The instrument uses these settings during discovery, traffic generation, and the network service test to make decisions about routing traffic.

In the preview pane, tap **802.1Q/IP TOS** to display the **Instrument Settings— 802.1Q/IP TOS** screen. This screen enables you to configure the instrument for tagged VLAN (802.1Q) and/or IP Type of Service (TOS) operation. These settings are applied globally to traffic from the instrument and remain in memory even after you turn it off.

It is important that you configure these settings correctly. If you select a VLAN ID that is not configured on the port that the instrument is connected to, the instrument may not be able to communicate with the network. DHCP will fail and active discovery will not work.

You can experience the same failure if you enable 802.1Q on the instrument but plug it into a port that is not enabled for 802.1Q. If this happens, you can use the VLAN Statistics test to identify the VLANs that are active on the port. Then, try configuring the 802.1Q settings for the VLAN that has the highest packet count.

- 1 In the **802.1Q Settings** section, do the following:
  - a Check **Enable 802.1Q** to select 802.1Q tagging mode.

This setting denotes a new frame format whereby every packet that is transmitted by the instrument contains an extra four bytes in the header to include fields for the VLAN ID and a priority level for the frame (see next two items). On the receive side, the instrument extracts and processes this information from incoming packets.
  - b Supply the **VLAN ID** (values range from 1 to 4094).
  - c Set **Priority**: select a value between 0 and 7 (low to high) to specify a priority level for the frame.
- 2 In the **TOS (Type of Service)** section, select one of the following:
  - **TOS with IP Precedence**. Then check one of the type of service parameters (**Delay**, **Throughput**, **Reliability**, or **Cost**) and select a priority in the **IP Precedence** box.

OR

  - **TOS with DSCP**. Then supply a value for DSCP (Differentiated Service Code Point).
- 3 Tap **Apply** to save your settings.

The instrument restarts its tests with the new configuration.

### Connection Log

The **Connection Log** shows the sequence of network events that occur while the instrument is establishing a connection to the network. Performance/ITO remote server usage is also logged. Connections to test devices, idle time, and refused connections are stored in the log, making it useful to monitor remote server usage.

### Ethernet Settings

On **Instrument Settings—Ethernet** screen, you can override the instrument's link auto-negotiation process and force MetroScope Service Provider Assistant to link at a user-selected speed and duplex.

To link at particular duplex setting, tap **Use Forced Setting**. Then select one of the settings in the **Forced Setting** group.

#### *Notes*

**Use Forced Setting** *applies to RJ-45 only.*

*An asterisk (\*) next to the value on the link button (located in the bottom- left corner of the task bar) indicates that the speed/duplex is a forced setting.*

At the bottom of this screen, a factory assigned MAC address is shown. You can change this address to enable testing of switch forwarding tables and ARP caches as part of the troubleshooting process.

## Instrument Security Settings

On the **Instrument Settings—Instrument Security** screen (Figure 8), you can provide password-level security for your MetroScope Service Provider Assistant.

This screen enables you to:

- Password-protect access to the instrument through the remote user interface.
- Authorize running of Performance tests.
- Prevent unauthorized users from editing the instrument’s SNMP community strings or viewing the remote user interface.



epi85s.bmp

Figure 8. Instrument Settings—Security Screen

## MetroScope™ Service Provider Assistant Getting Started Guide

---

If a field is password-protected, this symbol denotes that the field is secure: "\*". The fields and controls on the **Security** screen are disabled until a user successfully enters the password and logs in using the **Login** button.

On the **Security** screen, you can also configure the instrument's SNMP community strings. The default community strings are "public", "private", and "security". You can change the default strings to those that are used on your network.

### *Note*

*The discovery process successively tries the community strings in the order in which they are listed. For a quicker discovery, you should list the strings in order of frequency of use.*

## General Settings

On the **Instrument Settings— General** screen, you can change the following settings for the instrument:

- **Restore Defaults:** resets the instrument to the factory default settings. These include interface configurations and address settings.

If you restore the instrument's default settings, any changes that you made to the instrument and all current data is lost.

- **Edit user-defined devices:** lets you edit or delete existing user-defined devices, or add a new device that is either outside of the local broadcast domain or not being discovered.



- **Remote Performance Testing:** enables/disables the instrument to serve as the Performance remote server and to interoperate with another MetroScope Service Provider Assistant serving as the local unit during a remote test.
- Preferences
  - **Show vendor prefix with MAC address:** lets you control how a device's MAC address is shown. By default, it is shown with a vendor prefix. When the box is unchecked, the MAC address is shown in raw hexadecimal format.
  - **Enable paced discovery:** during the initial stages of discovery, the instrument generates a significant number of ARP requests and responses. If a switch detects a Denial of Service (DOS) attack, it may shut down the port to which the instrument is attached.

If you check this setting, you may be able to prevent the switch from shutting down the port. The instrument does not issue broadcast packets and sends fewer PING and ARP requests. The result is that it takes the instrument longer to completely discover your network.

- **Enable fast connect mode:** lets you quickly obtain a network link and DHCP address.

By default, when MetroScope Service Provider Assistant is first plugged into a network, it tries to determine whether it is connected to the same broadcast domain that it was previously connected to. If it determines that it is connected to the same network, it saves the data it previously collected.

Use the **Enable fast connect mode** setting when you repeatedly connect MetroScope Service Provider Assistant to different networks because usage results in a faster response time.

For example, select this setting when you are verifying the connectivity of multiple office cubicles in a new installation. In this mode, the instrument automatically resets its discovery database when changing the network connection or when returning to the **Test Results** screen from the **Cable Verification** screen.

- **Edit SNMP System Name:** lets you supply a new SNMP system name for the instrument.

## Reports

Having a well documented network can help you solve problems quickly when they arise and can even assist you with managing the security of your network. MetroScope Service Provider Assistant enables you to document the state of your network.

You can record network attributes, baseline performance, a device inventory, and switch-port statistics—all in XML-formatted files. You can add a company logo to your reports and even provide comments.

## Creating a Report

On most screens, a  button is available that enables you to create reports and save them in a web-viewable file. Reports are saved in the **Reports** directory.

To create a report:

- 1 Make sure that the CompactFlash memory card is installed in **SLOT 2**.

*Note*

*If a CompactFlash memory card is not detected, you are reminded to insert the card.*

- 2 Tap .

- 3 Tap **New Report**.



A default name is provided in the **Name** text entry box.

- 4 Use the virtual keyboard or an external keyboard to change the default name for the report.
- 5 If desired, supply descriptive information or a comment for the report in the **Comment** section.
- 6 Tap  to save.

## Managing Reports

The **File Manager** provides access to your saved reports, enabling you to view and rename them, and delete those that you no longer need.

To access the **File Manager**:

- 1 Tap .
- 2 Select  **Applications** from the drop-down list.
- 3 Tap  **File Manager** to display the list of saved files.

## Viewing Reports



You can view reports on the instrument and on a PC.

### Note

*You can use the remote access feature to view reports. See “Accessing the Instrument Remotely” on page 54 and the online Help for details.*

To view reports on the instrument:

### Note

*The following procedure shows you how to view a report from the **File Manager**. You can also view a report by tapping  followed by , and then tapping the report that you want to view.*

- 1 From the **File Manager** list, select the file you want to view.
- 2 Tap **File**. From the **File** menu, tap **Open** to view the contents of the file.

---

To view reports on a PC:

- 1 Copy the report files from the CompactFlash memory card's **Reports** directory to your PC.
- 2 Select the report that you want to view.

*Note*

*Report files have a .xml extension. Make sure that the file you select has this extension.*

- 3 Use the PC's web browser or Microsoft Excel to view the contents of the report.

### Renaming a Report

To rename a report:

- 1 From the **File Manager** list, select the file you want to rename.
- 2 Tap **File**.
- 3 From the **File** menu, tap **Rename**.  
The selected report is highlighted.
- 4 Type a new name for the file.

#### Deleting a Report

To delete a report:

- 1 From the **File Manager** list, select the file you want to delete.
- 2 Tap **File**.
- 3 From the **File** menu, tap **Delete**.
- 4 When prompted, tap .

The file is deleted from the CompactFlash memory card.

#### Adding a Graphic to Report Headers

To customize your reports, you can add a graphic, such as a company logo, to the report header. To do this, place a **.gif** file named

*yourCompanyLogo.gif*

in the root directory on the CompactFlash memory card.

The graphic is displayed on the left side of the report header in a 180 x 70 pixel area. Note that if you do not supply a graphic, the Fluke Networks logo is displayed.

#### *Note*

*The user-supplied graphic and Fluke Networks logo can only be seen if the report is viewed on a PC.*

### Adding an Instrument Comment to Report Footers

You can add an instrument comment to your report that appears in the footer. The comment is a simple text file that you create using an application such as Notepad.

To add a comment, place a file named

*instrumentComment.txt*

in the root directory on the CompactFlash memory card.

The instrument comment is displayed at the bottom of the report in the **Instrument Comment** field. Note that if you do not provide a comment file, the footer does not display the **Instrument Comment** field.

### Running the Diagnostic Tests

MetroScope Service Provider Assistant provides a set of specialized tests that you can use to diagnose specific network problems, such as connectivity and performance, and to obtain critical information about hosts, devices, and services on your network. These tests include the following:

- Ping
- Trace Route
- Trace Switch Route

## MetroScope™ Service Provider Assistant Getting Started Guide

---

You can access the diagnostics tests in one of two ways:

### *Note*

*The list of available tests differs depending on which method you use to access the tests.*

- Tap  and select the desired test from the list.
- OR
- Select a device. Then, tap [Details](#).

If the diagnostic test is available, it appears as a blue hyperlink in the preview pane. Tap the name of the diagnostic test to access it.

## Accessing the Instrument Remotely

You can control MetroScope Service Provider Assistant and view its result screens from a remote location. The instrument contains a Virtual Network Connection (VNC) server that is used for remote access.

To access the remote user interface:

- 1 Start Internet Explorer.

### *Note*

*MetroScope Service Provider Assistant supports Internet Explorer only.*

- 2 In the **Address** field, enter the IP address of the MetroScope Service Provider Assistant that you want to connect to.



The **MetroSCOPE Service Provider Assistant** web server home page (Figure 9) is displayed.



eyc107s.bmp

**Figure 9. Web Server Home Page**

From this screen, you can do the following:

- Access reports saved on the CompactFlash memory card or real-time reports in the instrument's active test results memory.
- Remotely access the instrument.

*Note*

*The remote instrument can be accessed by multiple users, but can be controlled by only one user at a time.*

- Initiate a support incident at the Fluke Networks website.
- Access the Help screens.

## MetroScope™ Service Provider Assistant Getting Started Guide

---

3 To remotely access the instrument:

- a Click **Launch Remote UI**.
- b Use the keyboard to type the Remote Authentication password. Then, click **OK**.

### Note

*The instrument's default factory setting requires no password. Therefore, clicking **OK** with no entry in the password field displays the **Test Results** screen. For security reasons, you can set a password to restrict usage to authorized users only. See "Instrument Security Settings" on page 45 for instructions.*

The remote instrument's **Test Results** screen is displayed. You are now connected and can control the instrument remotely.

4 To access real-time reports:

- a Click **Reports**.

The **MetroScope Real-Time Reports** screen is displayed.

- b Locate the report that you want to view, and then follow the link to view it.

5 To access saved reports:

- a Click **Reports**.

The **MetroScope Real-Time Reports** screen is displayed.

- b Click **View Saved Reports**.

- c Select the report that you want to view, and then follow the link to view it.

## User Interface Events That Terminate a Remote Session

The active TCP/IP session between the remote user interface software and the instrument can be severed under the following conditions:



- If IP parameters are manually changed on the instrument and **Apply** is selected on the **Instrument Settings—TCP/IP** screen
- If the **Start Test** button is selected on the **Cable Verification** details screen.
- If the instrument's MAC address is changed on the **Instrument Settings—Ethernet** screen.
- If the Ethernet link goes down.

## Using the Desktop Tools

MetroScope Service Provider Assistant is packaged with a number of tools to increase your productivity. The tools are listed in this section along with a brief description of their function.









### Applications Menu

The following tools are on the **Applications** menu. To display this menu, tap  then select **Applications**.

-  **Calculator:** performs basic arithmetic operations, such as addition and subtraction.
-  **Calendar:** provides weekly and monthly views for scheduling events; a **Notes** function enables you to add information about an event.

## MetroScope™ Service Provider Assistant Getting Started Guide

---

-  **Clock:** displays the time currently set on the instrument; includes a stop watch and alarm function. To change the time, see “Setting the Time and Date” on page 16.
-  **MetroScope Console:** provides a command line interface and terminal emulation (Telnet).
-  **MetroScope Service Provider Assistant:** returns you to the MetroScope application.
-  **File Manager:** displays the contents of the CompactFlash memory card where reports are stored.
-  **Report Viewer:** displays a saved report.
-  **System Info:** displays resource usage (memory, CPU, and storage) and version information of the Linux operating system.
-  **Web Browser:** displays MetroScope Service Provider Assistant’s web browser, Konqueror. You can use the browser to view and change the configuration of switches and other network devices.
-  **Server Response Tool:** a utility that enables you to test application server connectivity and responsiveness. You can identify, save, and test up to 100 server/port pairs.

## Tools Menu

You can access the following tools from the **Tools** menu. To display the menu, tap  (located on the toolbar).

- **Ping, Trace Route, and Trace Switch Route:** diagnostic tools.
- **Web Browser:** enables you to connect to a device so that you can check or change its configurations. To connect, select the desired device and then select **Web Browser**. The instrument's web browser, Konqueror, attempts to connect to the device.
- **Telnet:** lets you access a remote computer so that you can check or change its configurations. When you run this program, MetroScope Service Provider Assistant acts as if it is a terminal connected to the remote device.
- **SSH Telnet:** stands for Secure Shell Telnet, a more secure version of Telnet. To provide security, SSH Telnet requires login credentials. It also encrypts the data sent between the logical and remote device.
- **Terminal:** lets you use MetroScope Service Provider Assistant as an ASCII terminal. You can use a remote keyboard to enter commands or tap  to display the virtual keyboard.

### Note

To close the virtual keyboard, tap  again.

- **FTP:** starts an FTP (File Transfer Protocol) session with a device. Use this utility to transfer files between computers. To start a session, select a device, then select **FTP**.

- **TFTP:** stands for Trivial File Transfer Protocol, a data transfer utility that enables you to do firmware updates on switches that support its use.
- **CDP Port Reporter:** a command-line utility that uses the Cisco Discovery Protocol (CDP) to discover switches and switch details. You can use this utility in a Cisco environment to quickly discover and display information about a switch.
- **Report:** displays reports on the CompactFlash memory card. You can create a new report or delete or replace an existing report.

## Troubleshooting Your Instrument

This section lists some problems you might experience with your MetroScope Service Provider Assistant and provides suggestions to help you solve them. Before calling technical support, try these suggestions to see if you can solve the problem on your own.

**Problem:** The instrument or the application is not responding.

**Suggestion:** If you suspect that the application environment or the instrument (hardware) has locked up, you may have to completely shut down the instrument. To do this, press and hold the **On/Off** button for approximately six seconds.

**Problem:** The instrument does not power on.

**Suggestion:** Connect the instrument to the AC adapter. If the instrument powers on only when connected to the AC adapter, the internal battery may be completely discharged. Recharge the battery.

**Problem:** The user interface does not appear.

**Suggestion:** The **Test Results** screen should be displayed after you turn on the instrument.

If the screen does not display, press and hold the **On/Off** button for six seconds to completely shut down the instrument. Then, press the **On/Off** button again to power the instrument back on.

**Problem:** The IP Discovery and/or Tools results screens are not displaying the expected results.

**Suggestion:** Check the following:

- Does the instrument have a valid IP address? Select **Connection** on the **Test Results** screen to see if the instrument is configured with a valid IP address.
- Verify that the DHCP capability on the **Instrument Settings—TCP/IP** screen is not disabled. If an IP address is entered manually, it must not be an address within the local subnet.

## MetroScope™ Service Provider Assistant Getting Started Guide

---

**Problem:** The touch-sensitive screen responds slowly or erratically to the stylus.

**Suggestion:** Try navigating around the display to determine whether the touch-screen requires calibration (this is rare). If you suspect a problem with the calibration, see “Recalibrating the Screen” on page 16.

**Problem:** The instrument does not connect to the network.

**Suggestion:** The **LINK** LED lights solid green (if a link exists). In addition, you should see some activity on the **TRANSMIT** and/or **UTILIZATION** LEDs. If the LEDs indicate no activity on the link, do the following:

- Check the **Connection** test results on the **Test Results** screen. Select **Connection** and then check to see whether an IP address for the connection is displayed in the preview pane.
- (RJ-45 only) Confirm that the **Cable Verification** test passed. Try a different cable, if necessary. From the **Test Results** screen, tap  to expand the **Connection** test group and then select **Cable Verification**. Check the status and the test results information in the preview pane.



**Problem:** The instrument cannot connect to the network.

**Suggestion:** A network connection cannot be made if the **Cable Verification** (RJ-45 only) test does not pass.

Check status of the **Connection** test on the **Test Results** screen. Information in the **Status** column shows you whether or not a cable is detected. Do the following:

- 1 Tap  to expand the **Connection** test group.
- 2 Select **Cable Verification** and check the results of the test.

If the test fails, this icon is displayed: .

- 3 Tap **Details** to view detailed results to see if you can determine what is causing the problem.
- 4 To retest the cable, tap **Start Test**.

**Problem:**

- The battery charge state appears erratic or inconsistent.
- The battery does not hold a normal charge.

**Suggestion:** Charge the battery pack for at least seven hours.

**Problem:** The touch-sensitive screen does not respond at all to input.



**Suggestion:** Press the **On/Off** button to place the instrument in standby mode (see “Conserving Battery Power” on page 18). Press the **On/Off** button again to take the instrument out of standby mode.

If the problem continues, press and hold the **On/Off** button for six seconds to completely shut down the instrument. Press the **On/Off** button again to power the instrument back on.

## Specifications

Weight	0.82 kilograms (2 lbs)
Dimensions	19.1 x 15.2 x 4.4 centimeters, (7.5 x 6 x 1.75 inches)
LCD touch screen display	640 x 480 pixels, TFT (active) color panel, active area 129.6 (H) mm x 97.4 (V) mm
LED indicators (mainframe)	6
Battery	Lithium Ion 7.2 V DC (nominal), 4.2 Ah
Battery life	Approximately 4 hours; Fiber Mode: approximately 3.5 hours
External AC adapter/battery charger	AC input: 120 V – 240 V, 50/60 Hz, 1.5 A; DC output: 15 V, 3.3 A
Communication and accessory ports	One USB, one CompactFlash memory card (Card Type I/II), one DB-9 serial, headphone jack

## Specifications (continued)

Network analysis ports	RJ-45 10/100/1000 BASE-T Ethernet, 1000BASE-SX/LX/ZX Fiber, 100BASE-FX Fiber
Vibration	Meets requirements of MIL-PRF-28800F for Class 2 random vibration
Laser	 Class 1 Laser Product. Complies with 21 CFR Subchapter J and EN 60825-1/01
Environmental	<p>Operating temperature: 0° C to 45° C with 95 % relative humidity</p> <p>Non-Operating (storage) temperature: – 20° C to + 60° C</p> <p> Electromagnetic Interference complies to EN61326, Class A. Criteria C</p> <p> The product network interfaces are NOT FOR CONNECTION TO PUBLIC TELEPHONE SYSTEMS and should only be connected to the public phone network through regulatory agency compliant modem devices</p>
MetroScope Certifications and Approvals	CSA Canada & United States, CE, FCC Part 15 Class A, C-TICK N10140; UL and CSA approvals for universal AC adapter

#### Cable Types

- Unshielded Twisted Pair LAN cables (100 UTP category 3, 4, 5, 5E, and 6 ISO/IEC Class C and D)
- Foil-screened Twisted Pair cables (100 and 120 Ohm ScTP category 3, 4, 5, and 6 ISO/IEC Class C and D)
- Identifies and operates with the optional fiber adapter, LX (1310nm, -3 dBm (0.50 mW max)), SX (850nm, -2 dBm (0.63 mW max)), ZX (1550nm, +4 dBm (2.5 mW max)), or FX (1310 nm, -14 dBm (0.4 mW max)).

#### Cable Length

- Open or shorted with wiremap adapter: 1 to 305 m (3 ft. to 1000 ft.)
- Terminated with  $\geq 20$  % reflection: 1 to 305 m (3 ft. to 1000 ft.)

#### Note

*Length accuracy depends on the cable type selected on the **Cable Verification** screen.*

#### Receive Level

100 to 5000mVp-p

#### Datalink Signal

500mVp-p to 4000mVp-p

#### Measuring Terminated Cables

Cable Verification tests individual twisted-pairs of a cable that are terminated into most equipment vendors' Ethernet ports, such as on a hub, switch or NIC.

All cable tests other than WireView wiremap and office locator ID are operational in the presence of datalink signal.

**Fault Tolerance**

The RJ-45 10/100/1000 BASE-T Ethernet connection on the instrument is designed to withstand a maximum of 100 volts.

**WireView Wiremap Adapter/Office Locator  
Compatibility**

Detects combinations of shorts, opens, and connector miswires. Compatible with Fluke Networks WireView wiremap adapter/office locator.



# Index

## Numerics

10/100/1000 BASE-TX, 21  
1000BASE-SX, -LX, -ZX and 100BASE-FX, 21  
802.1Q/IP TOS settings, 42

## –A–

AC adapter charger, 17  
actual link speed and duplex mode, 27  
Appearance icon, 30  
Applications menu, 28, 57  
auto charger, 17  
auto-negotiation, overriding, 44  
autotest results, viewing, 35

## –B–

Back button, 28  
background screen color, changing, 30

## battery

charging, 17  
conserving power, 18, 29  
icon, 29  
installing, 18  
blue text, 30  
brightness, adjusting, 15

## –C–

calculator, 57  
calendar, 57  
care and maintenance instructions, 10  
clipboard icon, 29  
clock, 58  
column sort, 30  
command line interface, 58  
CompactFlash memory card, 5, 22, 49  
configuring the instrument, 40

## MetroScope Service Provider Assistant Getting Started Guide

---

CPU information, displaying, 58  
customizing the instrument, 30

### –D–

Date/Time icon, 30  
date/time, setting, 16  
DB-9 port, 22  
DC power jack, 22  
desktop icon, 28  
Details button, 28  
diagnostic tests, 53  
documentation and reports, 48

### –E–

ERROR LED, 25  
Ethernet settings, 44  
external interfaces, 22

### –F–

factory default settings, restoring, 46  
fast connect mode, 47, 48  
fiber LAN, monitoring, 36  
File Manager, 50, 58  
Fluke Networks, contacting, 10

FTP tool, 59

### –G–

General settings, changing, 46  
graphic header, adding, 52

### –H–

headphone jack, 22  
Help  
    button, 28  
    changing the default language, 31  
    context-sensitive, 31  
    online documentation, 32  
Home button, 28  
hyperlinks, 30

### –I–

icons  
    battery level indicator, 29  
    calculator, 57  
    calendar, 57  
    clipboard, 29  
    clock, 58  
    Cut & Paste, 29



---

- Desktop, 28
- File Manager, 58
- keyboard, 29
- Light & Power, 29
- MetroScope Console, 58
- MetroScope Master Menu, 14, 27, 40
- MetroScope Service Provider Assistant, 29, 58
- Report Viewer, 58
- Reports, 28
- Settings menu, 29
- Sound, 29
- Suspend mode, 29
- System Info, 58
- Web Browser, 58

Instrument Security settings, 45

Internet Explorer, 54

## –K–

- keyboard icon, 29
- Konqueror, 58

## –L–

- language support, 14
- LEDs, 24

- Light & Power icon, 29
- LINK LED, 24

## –M–

- MAC address, 44, 47
- main pane, 26
- memory information, displaying, 58
- MetroScope Console icon, 58
- MetroScope Master Menu icon, 14, 27, 40
- MetroScope Service Provider Assistant
  - care and maintenance, 10
  - CD, 5, 32
  - configuring, 40
  - customizing, 30
  - date/time, setting, 16
  - factory default settings, restoring, 46
  - features, 2
  - language support, 14
  - LEDs, 24
  - network connections, 21
  - optional accessories, 6
  - power supply, 17
  - registering the instrument, 9
  - remote access, 54
  - safety information, 7

- safety regulations, 8
- security settings, 45
- Settings menu, displaying, 29
- specifications, 64
- turning on and off, 11
- user interface, 26

microphone jack, 22

monitoring a fiber LAN, 36

monitoring a wired LAN, 33

## **–N–**

- network connections, 21
- network, connecting to, 34

## **–P–**

- password, setting, 45
- personalizing the instrument, 30
- Ping, 53
- Port Reporter tool, 60
- power LED, 26
- power supply, 17
- preview pane, 26
- problems, troubleshooting, 60

## **–R–**

- recalibrating the screen, 16
- registering MetroScope Service Provider Assistant, 9
- remote control, 54
- renaming a report, 51
- Report button, 49
- Report tool, 60
- Report Viewer, 58
- reports
  - adding a graphic header to, 52
  - adding comments, 49
  - creating, 49
  - deleting, 52
  - managing, 50
  - renaming, 51
  - viewing, 50
- reports icon, 28
- Restart all button, 28

## **–S–**

- safety information, 7
- safety regulations, 8
- screen
  - adjusting brightness, 29

- background color, changing, 30
  - left and right panes, 26
  - recalibrating, 16
- security settings, 45
- serial DB-9 jack, 22
- Server Response Tool, 58
- SFP fiber adapter, installing, 37
- SLOT 1, 22
- SLOT 2, 22
- SNMP community strings, 45
- software, updating, 12, 14, 27, 40
- sorting data, 30
- Sound icon, 29
- sound, adjusting, 29
- SSH Telnet (Secure Shell Telnet) tool, 59
- standby mode, 29
- status bar, 28
- stylus, 4, 12
- System Info icon, 58

## **-T-**

- TCP/IP settings, 41
- Telnet tool, 59
- terminal emulation (Telnet), 58
- Terminal tool, 59

- Test Results screen, 35
- TEST STATUS LED, 25
- TFTP (Trivial File Transfer Protocol) tool, 60
- title bar, 27
- toolbar, 27
- Tools button, 28
- Tools menu, 59
- tools menu, accessing, 54
- Trace Route, 53
- Trace Switch Route, 2, 53
- TRANSMIT LED, 25
- troubleshooting, 60
- turning the instrument on/off, 11

## **-U-**

- USB keyboard, 29
- USB port, 22
- user interface, 26
- UTILIZATION LED, 24

## **-V-**

- version information, displaying, 58
- Virtual Network Connection (VNC) server, 54
- VLAN ID, 43

volume, adjusting, 29

**–W–**

web browser (Konqueror), 58, 59

Web Browser tool, 59

wired LAN, monitoring, 33

