

# HAKKO 472/473

DESOLDERING TOOL

## INSTRUCTION MANUAL

Thank you for purchasing the Hakko 472/473 Desoldering Tool.

### Table of Contents

Packing List .....	1
Precautions .....	1
Specifications .....	2
Part Names .....	2
Preparation .....	3
Desoldering .....	4
Replacing Parts .....	5
Maintenance .....	6
Troubleshooting Guide .....	8
Parts List	
Hakko 807 Desoldering Iron .....	9
Hakko 472 Station .....	10
Hakko 473 Station .....	12
Iron Holder .....	14
Replacement Parts .....	14
Wiring Diagram .....	15

### Packing List

Please make sure that all the items listed below are included in the Hakko 472/473 package.

Station	Spring Filter x 3
Desoldering Iron	Cleaning Pin (for $\varnothing$ 1.0mm (0.04 in.) Nozzle)
Iron Holder	Cleaning Pin/L (for Heating Element)
Cleaning Pin Holder	Cleaning Drill (for $\varnothing$ 1.0mm (0.04 in.) Nozzle)
Cleaning Sponge	Cleaning Brush
Filter Pipe w/Spring Filter/Filter Holder/Ceramic	Spanner
Paper Filter (L)	Silicone Grease
Ceramic Paper Filter (S) x 2	Instruction Manual
Ceramic Paper Filter (L) x 4	

### Precautions

#### High Temperature

The heating element, filter pipe, and other parts near these parts are all extremely hot during and immediately after operation. Be careful not to touch these parts at these times.

#### Filter

Be sure to use the appropriate filters for the station (ceramic paper filter (S)/filter case) and the iron (ceramic paper filter (L)/filter pipe). Using the wrong filter may result in a power drop or damage to the unit.

#### Mishandling

Sharp impacts may cause parts to break or the power to drop. Handle the desoldering iron station with care.

#### Maintenance

With proper care, the Hakko 472/473 can provide years of reliable service. Be sure to inspect the station and iron regularly following the maintenance procedures on page six (6) of this instruction manual.

#### Fluid (Hakko 473)

Use clean, filtered air as the fluid. With the button pressed and air flowing, adjust the pressure to between 71 and 100 psi. (5.0 and 7.0 kgf/cm<sup>2</sup>).

# Specifications

Station	Hakko 472	Hakko 473
Power Consumption	120V AC, 110W	120V AC, 80W
Vacuum Pressure	600 mm Hg (24 In. HG)	700 mm Hg (28 In. HG)
Flux Absorption	12 liters/min.	28 liters/min.
Voltage Leakage	Under 2 mV	Under 2 mV
Ground Resistance	Under 2Ω	Under 2Ω
Motor Output	12W	—
Applied Air Pressure	—	71 psi (5.0kgf/cm <sup>2</sup> )
Compressed Air Consumption	—	1.62 c.f.m. (46 liters/min.)
Outer Dimensions (W x H x D)	165 x 135 x 260 mm (6.5 x 5.31 x 10.24 in.)	165 x 135 x 260 mm (6.5 x 5.31 x 10.24 in.)
<b>Desoldering Iron</b>		
Power Consumption	24V AC, 60W	24V AC, 60W
Temperature Range	350~450°C (662~842°F)	350~450°C (662~842°F)

# Part Names

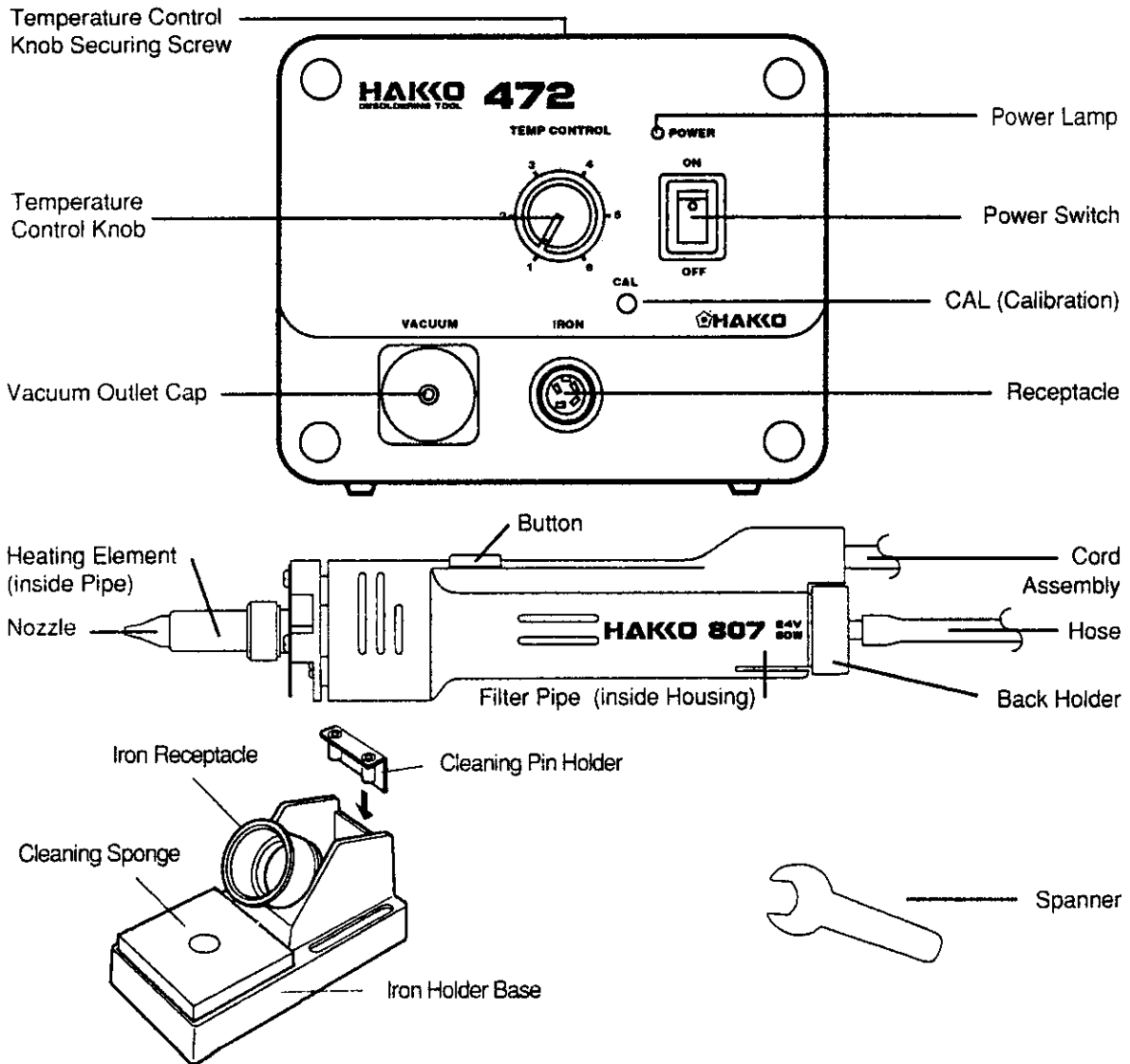

Before proceeding, confirm that the power switch is turned to "OFF."

### Assemble the Iron Holder

- Dampen the capillary sponge (small round sponge) with water and squeeze it dry. Place it in any one of the four round openings in the iron holder base.
- Fill the base with water to the level shown in the illustration at right.
- Place the cleaning sponge on the base.
- Insert the cleaning pin holder into the base. (See illustration at right)

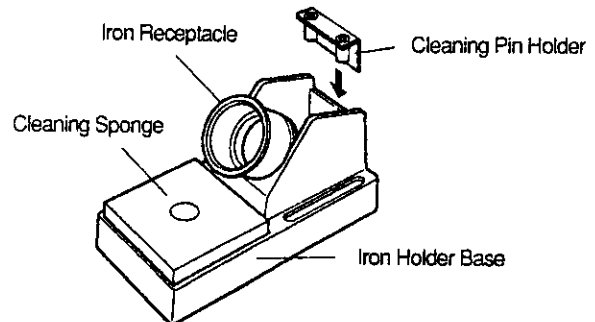

### Caution:

Use only a dampened and wrung cleaning sponge to clean the nozzle. Using a dry sponge will reduce the life of the nozzle.

### Notes:

- The sponges are compressed. They will swell when moistened with water.
- The capillary sponge will absorb water from the reservoir and, by capillary action, transfer water to the cleaning sponge, thus keeping the cleaning sponge moist at all times.
- The cleaning sponge may be used by itself by dampening it, squeezing it dry, and placing it on the iron holder base. It is not necessary to use the capillary sponge or add water to the reservoir.

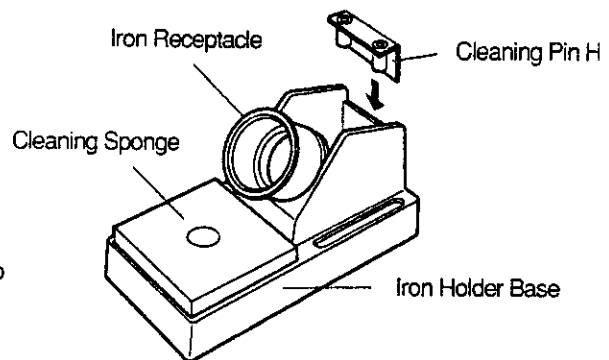

### Assemble the Desoldering Iron

- Insert the filter pipe (w/filter holder/spring filter /ceramic paper filter (L)) into the housing.
- Push and turn clockwise the back holder.

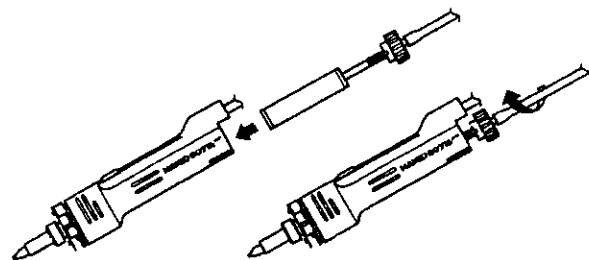

### Connect the Desoldering Iron to the Station

- Insert the 6-pin connecting plug into the receptacle on the station. Lock the plug by turning the plug's outer ring clockwise.
- Place the desoldering iron in the iron holder.
- Connect the hose to the vacuum outlet cap.

### Plug the Station into a Power Source

- Plug the power cord into a grounded AC outlet.
- Turn the power switch to "ON".

*After turning on the power, wait three (3) minutes before beginning desoldering operations.*

## Connect the Compressor (473)

1. Use filtered air to clean away any dust, oil and moisture.
2. With the button pressed and air flowing, adjust the regulator air pressure to 71 psi (5.0kgf/cm<sup>2</sup>).

### Caution:

1. The absorption power of the unit will be reduced if adjustment is made while air is not flowing or if the tube is not measured as specified.
2. Do not set the regulator to pressures of 128 psi (9kgf/cm<sup>2</sup>) or higher while the button is not pressed, as such pressures can damage various parts of the station.

## Set the Temperature

The temperature can be adjusted to between 662°F and 842°F with the temperature control knob. This unit has excellent thermal recovery, permitting it to operate at lower temperatures than conventional desoldering tools.

- The temperature can be more precisely set using a soldering iron thermometer. Adjust the temperature control knob until the measured temperature at the nozzle is the desired temperature.
- The temperature control knob can be secured by tightening the temperature control knob securing screw ("+" screw at the top of the unit).

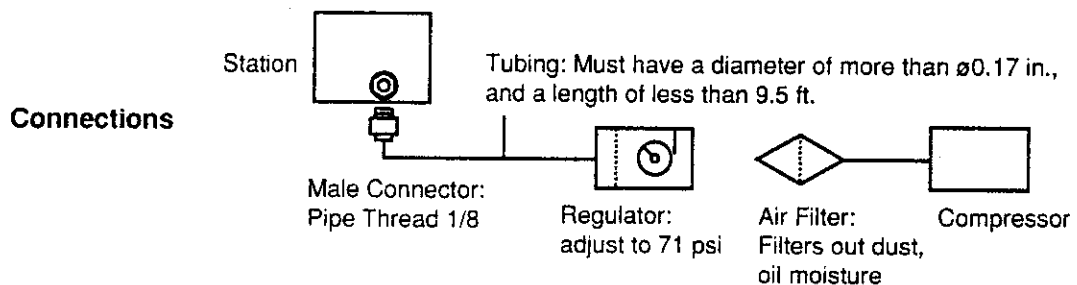

# Desoldering

1. Apply the nozzle to the soldered lead and melt the solder.
2. Confirm that the solder is melted by placing the nozzle against the lead and carefully applying slight pressure to the lead. If the lead moves, the solder is melted. Never move the lead by force. If the lead does not move easily, the solder is not fully melted.
3. Absorb the solder by pressing the button on the iron.
4. If solder remains, resolder the component.

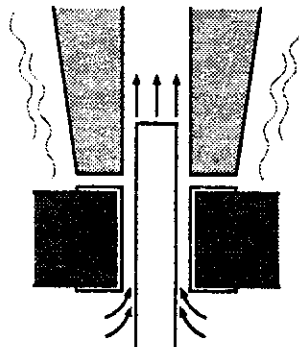

Absorb the solder by slowly moving the lead back and forth with the tip of the nozzle.

## Replacing the Nozzle

1. Remove the nut using the supplied spanner.
2. Disassemble the heating parts.
3. Replace the nozzle.

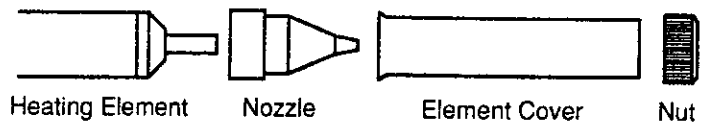

## Replacing the Filters

1. Turn the back holder knob counterclockwise and pull out the filter pipe.
2. If there is solder in two-thirds of the spring filter, replace the filter.
3. If the ceramic paper filter is stiff with flux and solder, replace the filter.
4. Insert the spring filter into the filter pipe.
5. Insert the ceramic paper filter into the filter pipe.
6. Insert the back holder into the filter pipe.
7. Insert the filter pipe into the main body and secure it by turning the back holder knob clockwise.

### CAUTION

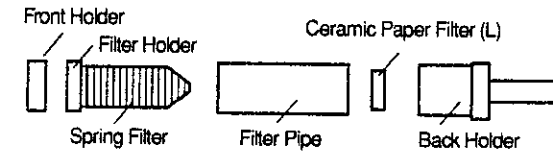

Insert the Filter Holder into the wide end of the Spring Filter and push it firmly into place.

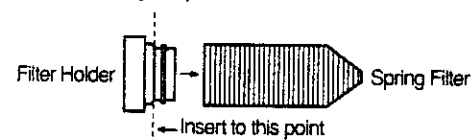

## Replacing the Heating Element

The resistance values of a working heating element are  $9.2\Omega$  between pins 1 and 3 (heating element), and  $54\Omega$  between pins 2 and 4 (sensor) at  $23^\circ\text{C}$  ( $73^\circ\text{F}$ )—Fig. 4. If the measured values are outside this range, replace the heating element.

1. Unplug the power cord.
2. Disassemble the heating parts.
3. Turn the back holder knob counterclockwise and pull out the filter pipe.
4. Remove the housing fastener (8).



Fig. 1

5. Remove the screws securing the housing (10) and the flange (3), (4).

6. Remove the front holder (11).

7. Remove the screws (5), (6), (7) securing the heating element to the flange, and the screws (1), (2).

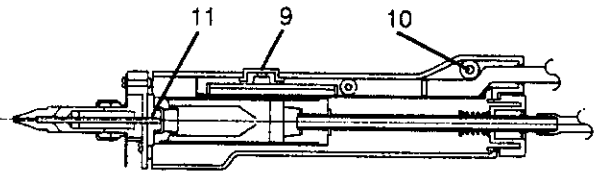
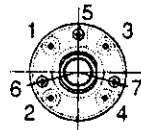

Fig. 2

8. Desolder the heating element and sensor leads.

9. Secure a new heating element (24V-60W) to the flange with screws (5), (6), (7). Install the heater in such a way that the lead wires are oriented as in Fig. 3.

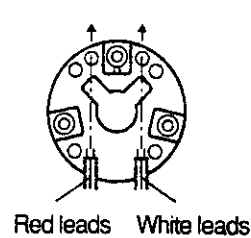

Fig. 3

10. Install the front holder.
11. Resolder the heating element and sensor leads.

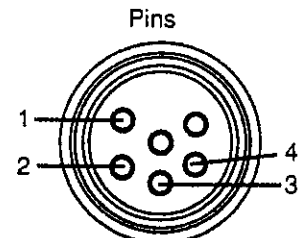
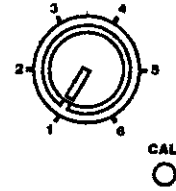

Fig. 4

12. Reassemble the unit.
13. Recalibrate the temperature.

The resistance value of new heating elements varies, resulting in variations in operating temperature. It is necessary to recalibrate the temperature every time the heating element is replaced.

1. Set the temperature control knob to "1" and allow the iron to warm up for three (3) minutes.
2. Adjust the temperature calibrator ("CAL") until the nozzle temperature (measured with a tip thermometer) is 350°C (662°F).



## Maintenance

Properly maintained, the Hakko 472/473 desoldering tool will provide years of good service. During many of the maintenance procedures, the desoldering iron will be extremely hot. Please wear gloves and work carefully.

### Clean the Nozzle with the Nozzle Cleaning Pin

1. Turn the power switch to "ON" and let the nozzle heat up.
2. Clean out the hole of the nozzle with the nozzle cleaning pin.

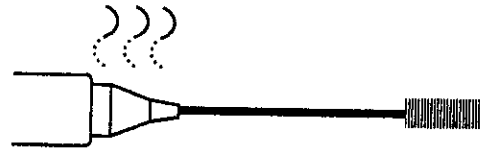

### Clean the Nozzle with the Nozzle Cleaning Drill

1. Turn the power switch to "ON" and let the nozzle heat up.
2. Turning the drill bit clockwise, insert it all the way into the nozzle.
3. Without turning the drill bit, pull it straight out from the nozzle.

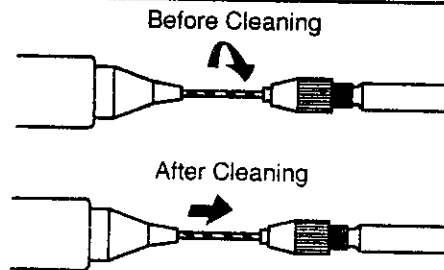

### Clean Out the Hole in the Heating Element

1. Disassemble the heating element.
2. Turn the power switch to "ON" and let the heating element heat up.
3. Scrape away all accumulated oxidation from the hole in the heating element until the cleaning pin passes cleanly through the hole.



### Clean the Inside of the Filter Case

1. Being very careful not to let the valve pop out, detach the filter retainer.
2. Remove the ceramic paper filter and inspect it. If it is stiff with flux, replace it.
3. Using only alcohol, remove any flux adhering to the filter retainer and the valve.
4. Apply silicone grease to the O-ring of the vacuum outlet retainer (472/473) and to the packing of the filter retainer (472). Securely tighten the vacuum outlet cap to prevent air leakage.

#### VACUUM

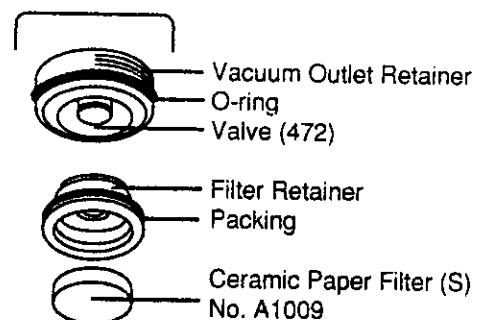

## Clean the Pump (472)

1. Unplug the power cord.
2. Remove the rear panel and the cover.
3. Remove the pump head from each side of the pump.
4. Remove the valve plate and the fixing plate. If the fixing plate is difficult to remove, warm it with hot air. Never use excessive force to remove the plate as it is easily bent.
5. Using only alcohol or thinner, remove any flux adhering to the plates.
6. If the exhaust filter is dirty, replace it.

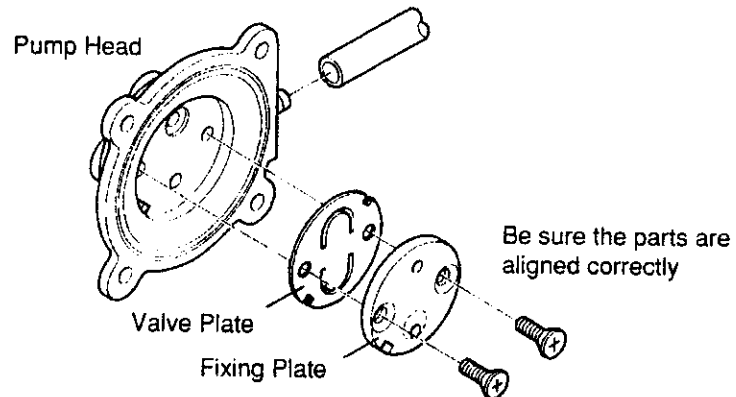
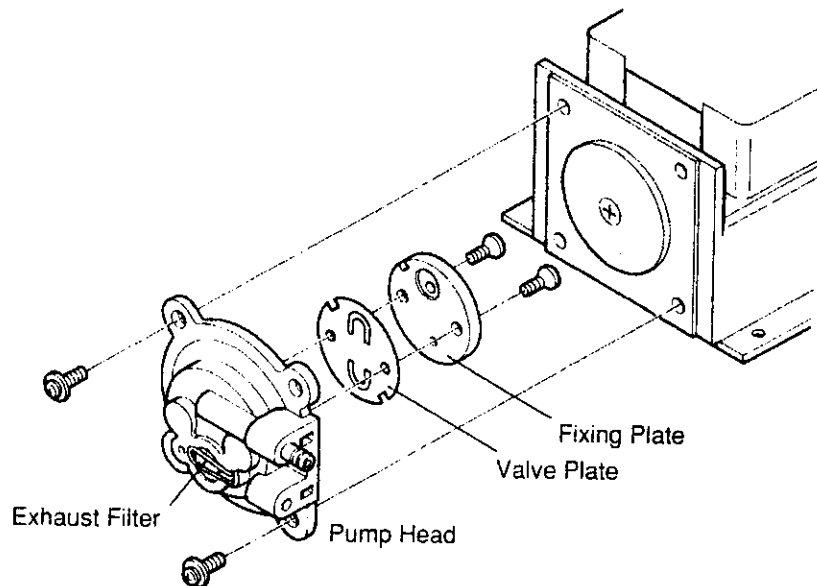
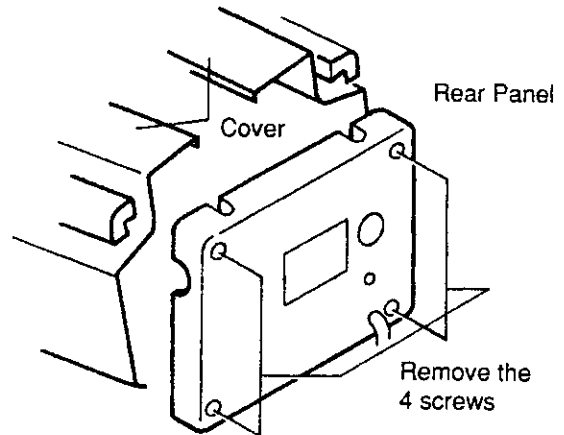

### Disassemble the Ejector (473)

1. Remove the exhaust filter covering the ejector. If the filter is dirty, replace it.
2. Remove the ejector cover and inspect the noise filter (No. B1269). If the filter is dirty, replace it.
3. Remove the exhaust pipe and spacer inside the ejector. Pinch the tip of the exhaust pipe and pull firmly. Both the spacer and the exhaust pipe will come out together.

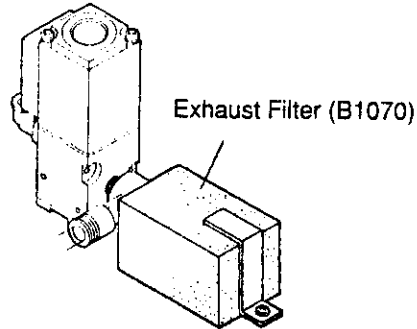

### Clean the inside (473)

1. Clean the inside of the main body of the ejector, the tip of the nozzle and the surrounding area. Remove any dirt with a cotton swab soaked in alcohol.

#### Caution:

Do not use thinner as a cleaning agent.

2. Soak the exhaust pipe in alcohol and clean the inside of the pipe with a soft stick-like material.

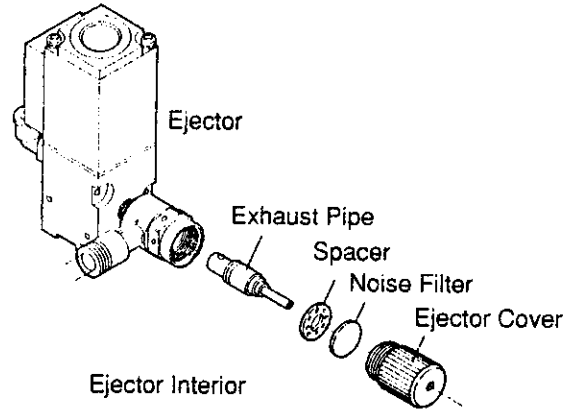

### Reassemble the Ejector (473)

Follow the disassembly steps (above) in reverse order.

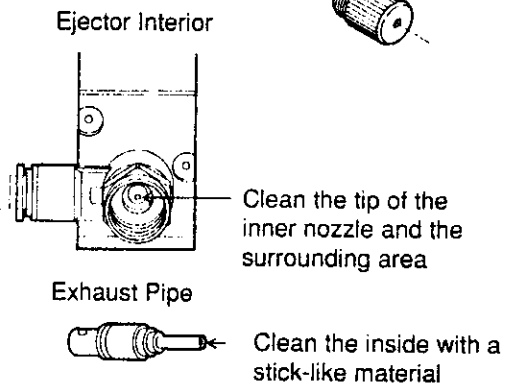

## Troubleshooting Guide

### Power lamp does not light up

- Is the power cord plugged in correctly?
- Is the fuse blown?

### Pump does not operate

- Is the cord assembly properly connected?
- Is the nozzle or hole in the heating element clogged?

### Solder is not being absorbed

- Is the spring filter full of solder?
- Is the ceramic paper filter hardened?
- Is there a vacuum leak?

### Nozzle does not heat up

- Is the desoldering iron cord assembly properly connected?



## Hakko 807 Desoldering Iron

Note: Spare or repair parts do not include mounting screws, if they are not listed on the description. Screws must be ordered separately.

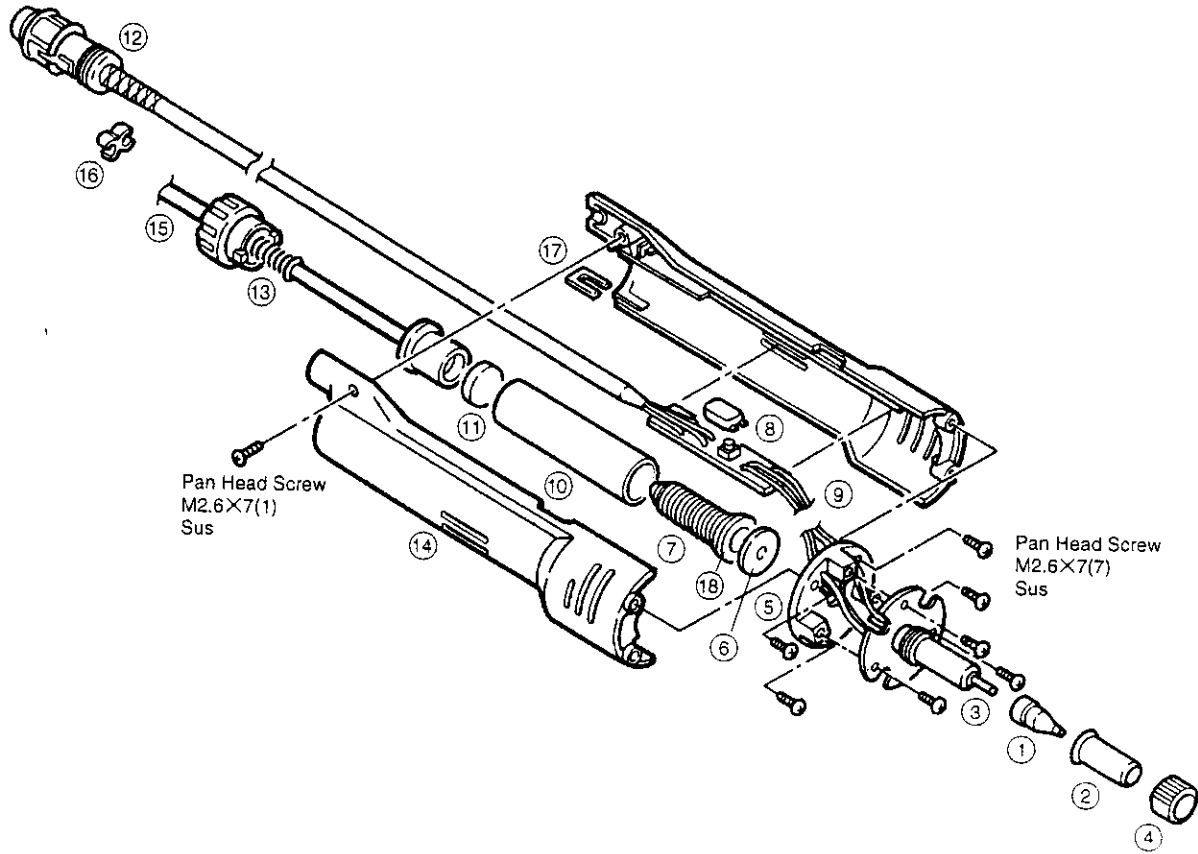

Item No.	Part No.	Part Name	Description
1		Nozzle/See Replacement Parts	
2	B1653	Element Cover	
3	A1174	Heating Element	24V-60W
4	B1015	Nut	
5	B1654	Flange	
6	A1304	Front Holder	
7	A1030	Spring Filter	Set of 10
8	B1655	Button	
9	B1656	Board w / Switch	
10	B1916	Filter Pipe	
11	A1033	Ceramic Paper Filter-L	Set of 10
12	B1657	Cord Asse'y	
13	B1917	Back Holder Asse'y	
14	B1659	Housing	w/a screw & Fastener
15	B1023	Hose / E.S.D.	
16	B1024	Cord Holder	Set of 4
17	B1660	Housing Fastener	
18	B1915	Filter Holder	

## Hakko 472 Station

Note: Spare or repair parts do not include mounting screws, if they are not listed on the description. Screws must be ordered separately.

Item No.	Part No.	Part Name	Description
1	B1029	Vacuum Outlet Cap	
2	A1009	Ceramic Paper Filter (S)	for Filter Case 10 pcs.
3	B1030	Filter Retainer	with Packing
4	B1035	Packing	
5	B1032	Valve	
6	B1274	Vacuum Outlet Retainer	with O-ring (S20)
7	B1034	O-ring (S20)	
8	B1033	Solenoid	with Valve
9	B1038	Cover for Securing Screw	set of 4
10	B1662	Receptacle	

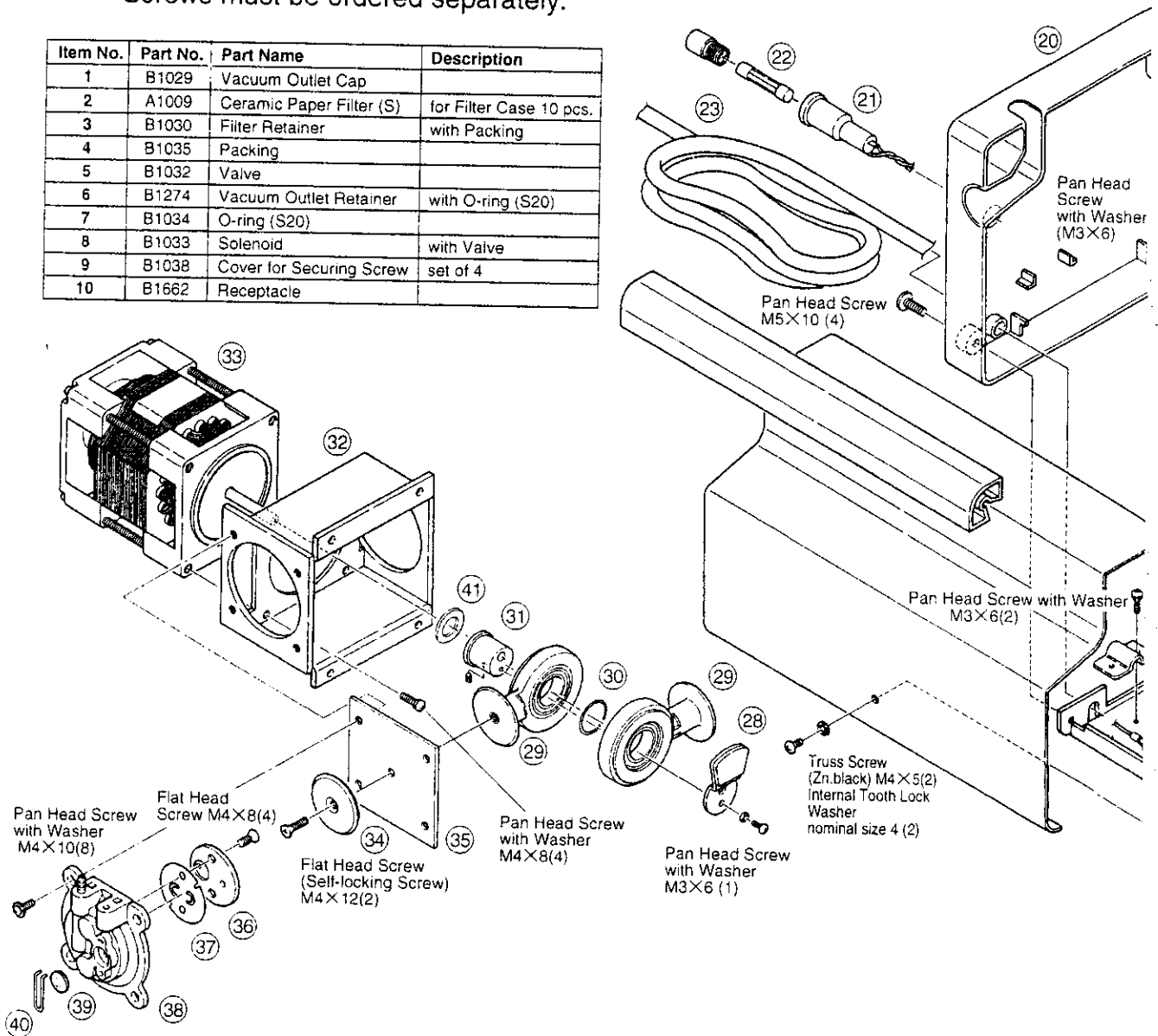

Item No.	Part No.	Part Name	Description
11	B1028	Knob	
12	B1661	Front Panel	
13	B1093	Cover	one side
14	B1061	Handle	one side
15	B1044	Temp. Control Set Screw Clamp	
16	B1664	P.W.B.	
17	B1046	Hose	with Spring (set of 2)
18	B1102	Transformer	
19	B1665	Pump	with Motor Capacitor
20	B1663	Rear Panel	with Rating Seal

Item No.	Part No.	Part Name	Description
21	B1041	Fuse Holder	w/o Fuse
22	B1275	Fuse	250V-2A(U)
23	B1104	Power Cord	
24	B1039	Chassis	
25	B1037	Rubber Stopper	set of 4
26	B1084	Switch	
27	B1078	Potentiometer	
28	B1053	Balance Weight	
29	B1312	Crank	with bearing
30	B1057	Ring for Bearing	



## Hakko 473 Station

Note: Spare or repair parts do not include mounting screws, if they are not listed on the description. Screws must be ordered separately.

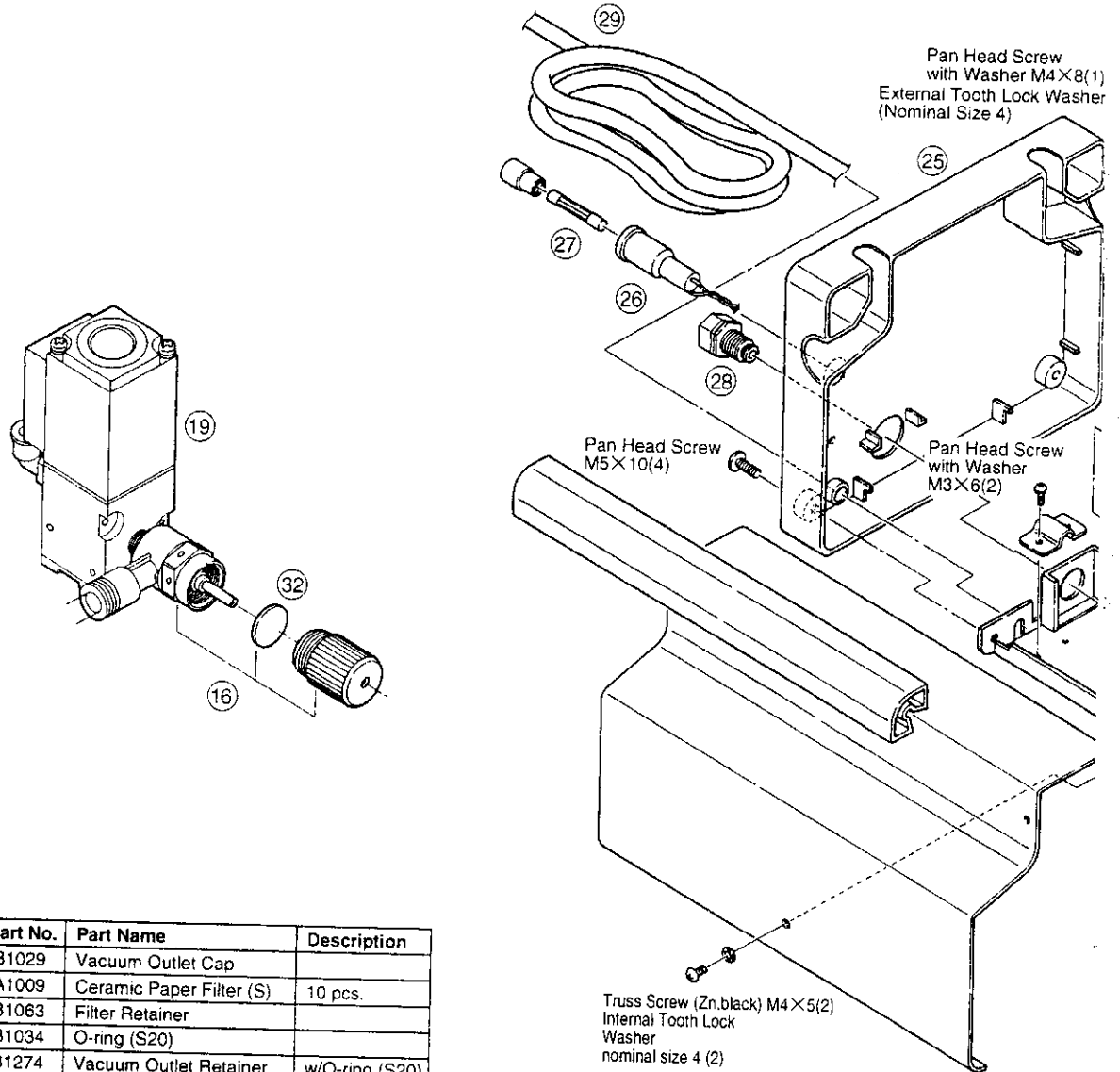

Item No.	Part No.	Part Name	Description
1	B1029	Vacuum Outlet Cap	
2	A1009	Ceramic Paper Filter (S)	10 pcs.
3	B1063	Filter Retainer	
4	B1034	O-ring (S20)	
5	B1274	Vacuum Outlet Retainer	w/O-ring (S20)
6	B1064	Filter Case Joint	
7	B1667	Front Panel	
8	B1038	Cover for Securing Screw	set of 4
9	B1662	Receptacle	
10	B1028	Knob	
11	B1093	Cover	one side
12	B1061	Handle	one side
13	B1044	Temp. Control Set Screw Clamp	
14	B1073	Joint Hose	
15	B1669	P.W.B.	
16	B1069	Ejector	

Item No.	Part No.	Part Name	Description
17	B1070	Exhaust Filter	
18	B1071	Exhaust Filter Retaining Clip	
19	B1074	Solenoid Valve	with Screws
20	B1075	Elbow Joint	
21	B1076	Pressure Hose	
22	B1103	Transformer	
23	B1067	Chassis	
24	B1037	Rubber Stopper	

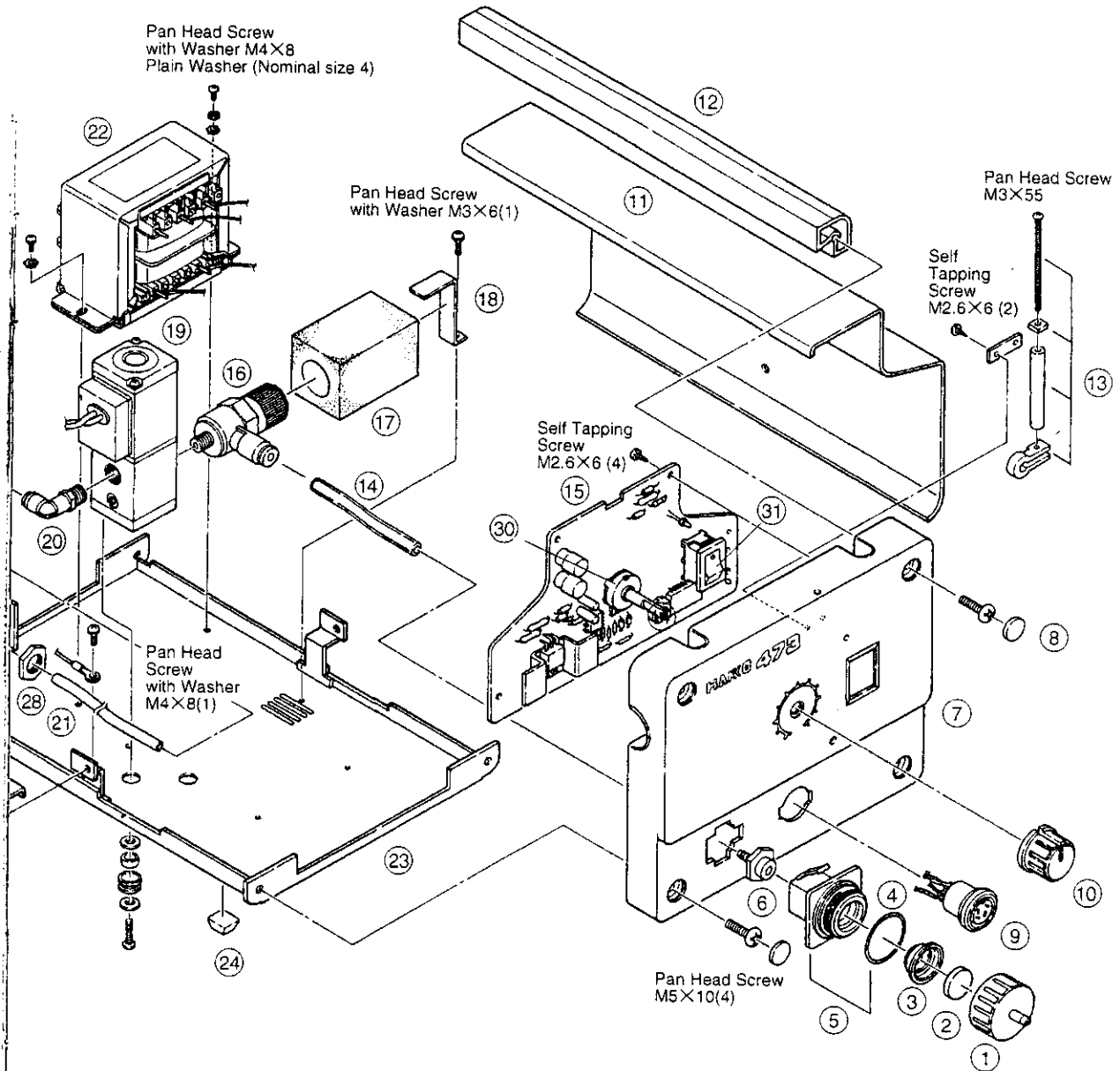

Item No.	Part No.	Part Name	Description
25	B1668	Rear Panel	with Rating Seal
26	B1041	Fuse Holder	w/o Fuse
27	B1275	Fuse	250V-2A (U)
28	B1127	Female Connector	
29	B1104	Power Cord	
30	B1078	Potentiometer	
31	B1084	Switch	
32	B1269	Noise Filter	

## Iron Holder

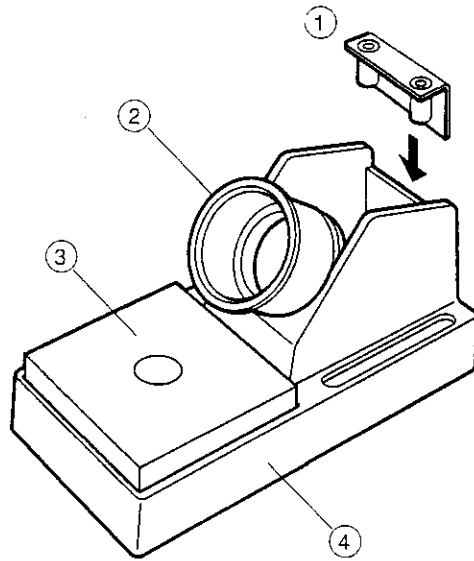

Item No.	Part No.	Part Name
1	B2312	Cleaning Pin Holder
2	B2311	Iron Receptacle
3	A1042	Cleaning Sponge
4	B2019	Iron Holder Base

## Replacement Parts

Part No.	Part Name / Specification
A1002	Nozzle S $\phi 0.8$ mm (0.03 in )
A1003	Nozzle S $\phi 1.0$ mm (0.04 in )
A1004	Nozzle $\phi 0.8$ mm (0.03 in )
A1005	Nozzle $\phi 1.0$ mm (0.04 in )
A1006	Nozzle $\phi 1.3$ mm (0.05 in )
A1007	Nozzle $\phi 1.6$ mm (0.06 in )
B1215	Cleaning Pin for Heating Element
B1086	Cleaning Pin for $\phi 0.8$ mm (0.03 in) Nozzle
B1087	Cleaning Pin for $\phi 1.0$ mm (0.04 in) Nozzle
B1088	Cleaning Pin for $\phi 1.3$ mm (0.05 in) Nozzle
B1089	Cleaning Pin for $\phi 1.6$ mm (0.06 in) Nozzle
B1302	Cleaning Drill for $\phi 0.8$ mm (0.03 in) Nozzle
B1303	Cleaning Drill for $\phi 1.0$ mm (0.04 in) Nozzle
B1304	Cleaning Drill for $\phi 1.3$ mm (0.05 in) Nozzle
B1305	Cleaning Drill for $\phi 1.6$ mm (0.06 in) Nozzle
B1670	Cleaning Brush
A1028	Silicone Grease
B2100	Spanner
C1316	Iron Holder for 807

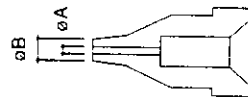

Part No.	$\phi A$	$\phi B$
A 1002	0.8 mm (0.03 in)	1.8 mm (0.07 in)
A 1003	1.0 mm (0.04 in)	2.0 mm (0.08 in)

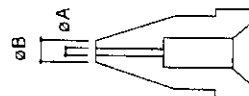

Part No.	$\phi A$	$\phi B$
A 1004	0.8 mm (0.03 in)	2.3 mm (0.09 in)
A 1005	1.0 mm (0.04 in)	2.5 mm ( 0.1 in)
A 1006	1.3 mm (0.05 in)	3.0 mm (0.12 in)
A 1007	1.6 mm (0.06 in)	3.0 mm (0.12 in)

Hakko 472

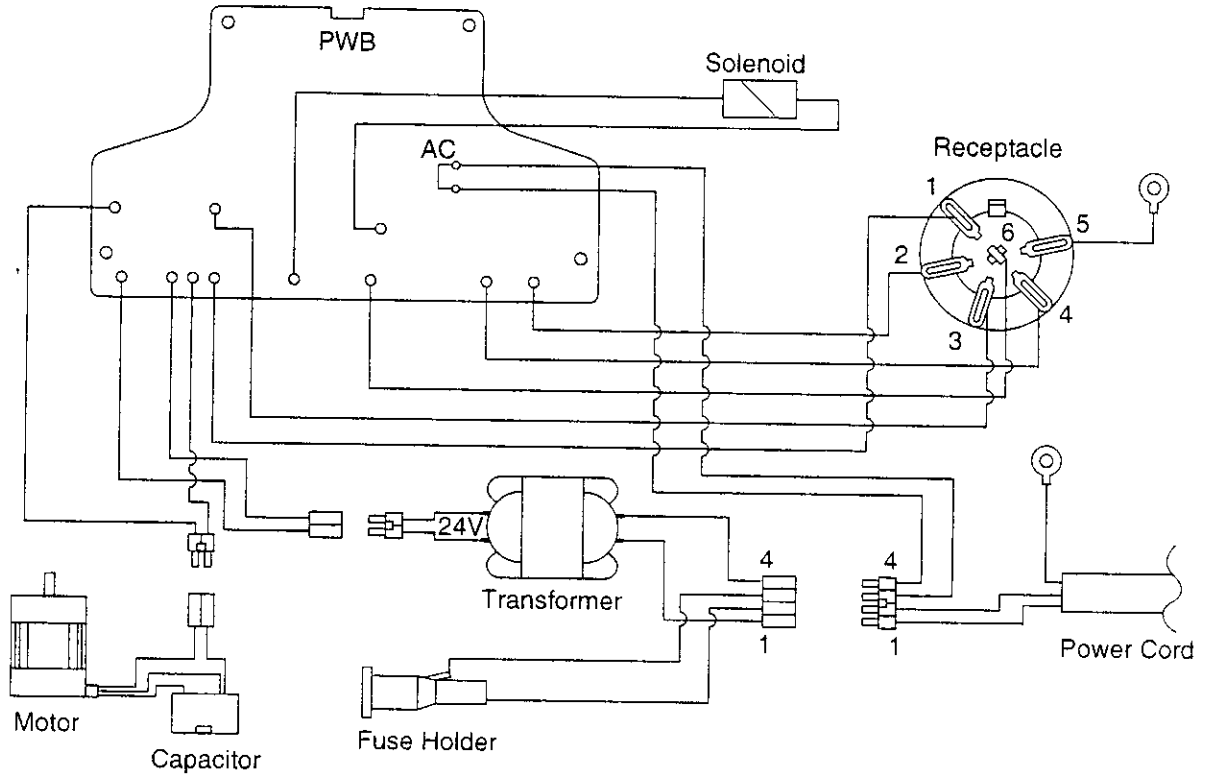

**Hakko 473**

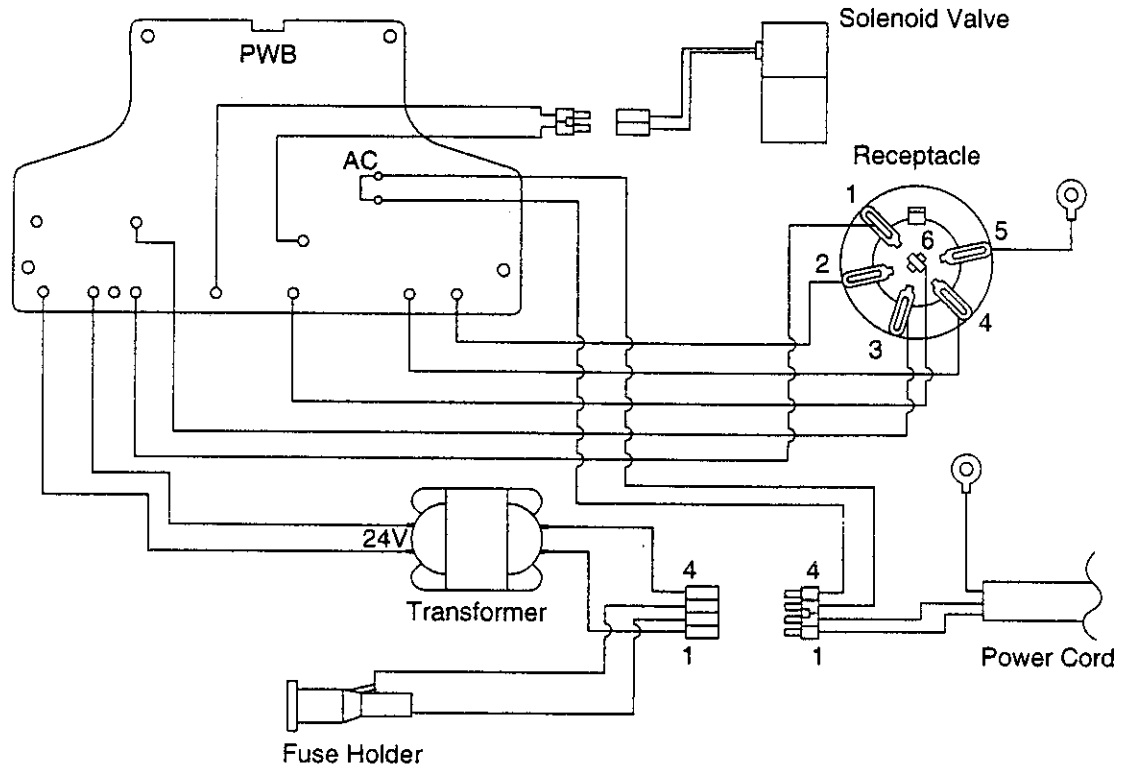

Jun. 1998



**HEAD OFFICE**  
4-5, SHIOKUSA 2-CHOME, NANIWA-KU, OSAKA, 556-0024 JAPAN  
TEL: (06) 561-3225 FAX: (06) 561-8466  
TLX: HAKKOOSA J65274

**AMERICAN HAKKO PRODUCTS, INC.**  
25072 ANZA DR. SANTA CLARITA, CA 91355, U.S.A.  
TEL: (805) 294-0090 FAX: (805) 294-0096  
Toll Free: (800) 88-HAKKO  
www.hakkousa.com