

HAKKO 472B/473 DESOLDERING TOOL

INSTRUCTION MANUAL

Thank you for purchasing the Hakko 472B/473 Desoldering Tool. Please read this manual before using the Hakko 472B/473. Store the manual in a safe, easily accessible place for future reference.

⚠ CAUTION : Remove the pump securing screw (M4 x 25 marked red) from the bottom of the unit.
Failure to do so may result in serious damage to the unit.

Table of Contents

Packing List.....	1
Safety Instructions.....	2
Specifications.....	3
Part Names	3
Preparation.....	4
Desoldering.....	5
Replacing Parts.....	6
Maintenance.....	7
Troubleshooting Guide.....	9
Parts List Hakko 472B Station	10
Hakko 473 Station	12
Hakko 807 Desoldering Iron.....	14
Iron Holder.....	15
Replacement Parts.....	15
Wiring Diagram.....	16

Packing List

Please make sure that all the items listed below are included in the Hakko 472B/473 package.

Station	Spring Filter x 3
Desoldering Iron	Cleaning Pin (for ø1.0mm (0.04 in.) Nozzle)
Iron Holder	Cleaning Pin/L (for Heating Element)
Cleaning Pin Holder	Cleaning Drill (for ø1.0mm (0.04 in.) Nozzle)
Cleaning Sponge	Cleaning Brush
Filter Pipe w/Spring Filter/Filter Holder/Ceramic	Spanner
Paper Filter (L)	Silicone Grease
Ceramic Paper Filter (S) x 2	Instruction Manual
Ceramic Paper Filter (L) x 4	

WARNING

Warnings, cautions are placed at critical points in this manual to direct the operator's attention to significant items. They are defined as follows:

 **WARNING:** Failure to comply with a WARNING may result in serious injury or death.

 **CAUTION :** Failure to comply with a CAUTION may result in injury to the operator, or damage to the items involved.
For your own safety, be sure to comply with these precautions.

CAUTION

**Remove the pump securing screw (M4 x 25 marked red) from the bottom of the station.
Failure to do so may result in serious problems.**

When the power is ON, the nozzle temperature is between 380°C and 480°C (716°F and 896°F).

Since mishandling may lead to burns or fire, be sure to comply with the following precautions.

- Do not touch the metal parts near the nozzle, nearby plastic parts and the spring iron holder.
- Do not use the product near flammable items.
- Advise those in the work area that the unit can reach very high temperatures and should be considered potentially dangerous.
- Turn the power OFF when no longer using the Hakko 472B or when leaving it unattended.

Before replacing parts or storing the unit, allow the unit to cool and then turn the power OFF.

To prevent accidents and failures, be sure to take the following precautions:

- Do not use the unit for applications other than desoldering.
- Do not rap the desoldering gun against the work bench to shake off residual solder, or otherwise subject the iron to severe shocks.
- Do not modify the unit.
- Use only genuine Hakko replacement parts.
- Do not wet the unit or use the unit with wet hands.
- Set the ceramic paper filter (S) for the filter retainer (station), and the ceramic paper filter (L) for the filter pipe (iron).
- Maintain the desoldering iron and the station.
While using the unit, don't do anything which may cause bodily harm or physical damage.
- (Hakko 473) Use clean, filtered air. With the button pressed and air flowing, adjust the pressure to between 71 and 100 psi. (5.0 and 7.0 kgf/cm²).

Specifications

Station	HAKKO 472B	HAKKO 473
Power Consumption	120V AC, 110W	120V AC, 80W
Vacuum Pressure	600 mm Hg (24 in. HG)	700 mm Hg (28 in. HG)
Suction Flow	15 liters/min.	28 liters/min.
Tip to Ground Potential	Under 2 mV	Under 2 mV
Tip to Ground Resistance	Under 2 Ω	Under 2 Ω
Motor Output	18W	—
Applied Air Pressure	—	71 psi (5.0kgf/cm ²)
Compressed Air Consumption	—	1.62c.f.m. (46 liters/min.)
Outer Dimensions (l x w x h)	260 x 165 x 135 (10.24 x 6.50 x 5.31 in)	260 x 165 x 135 (10.24 x 6.50 x 5.31 in)
Desoldering Iron		
Power Consumption	24V AC, 60W	24V AC, 60W
Temperature Range	350-450°C (662-842°F)	350-450°C (662-842°F)

Part Names

Temperature Control Knob Securing Screw

Temperature Control Knob

Vacuum Outlet Cap

Heating Element (inside Pipe)
Nozzle

Iron Receptacle

Cleaning Sponge

HAKKO 472B

TEMP CONTROL

POWER

VACUUM

IRON

HAKKO

Button

Filter Pipe (inside Housing)

Cleaning Pin Holder

Iron Holder Base

Power Lamp

Power Switch

CAL (Calibration)

Receptacle

Cord Assembly

Hose

Back Holder

Spanner

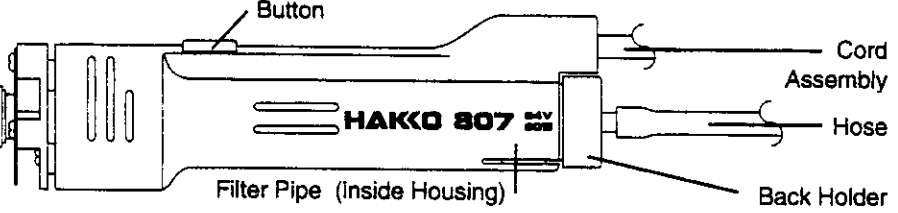
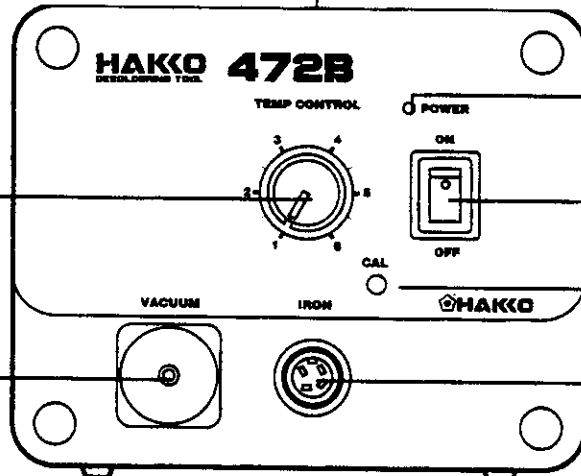
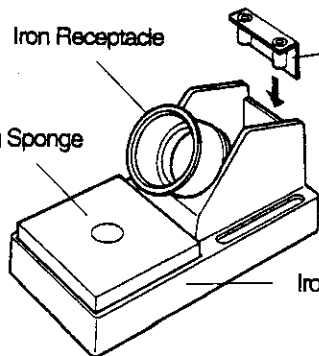

⚠ CAUTION : Remove the pump securing screw (M4x25, marked red) from the bottom of the unit before using the unit. Failure to do so may result in serious damage to the unit.

Before proceeding, confirm that the power switch is turned to "OFF."

Assemble the Iron Holder

- Dampen the capillary sponge (small round sponge) with water and squeeze it dry. Place it in any one of the four round openings in the iron holder base.
- Fill the base with water to the level shown in the illustration at right.
- Place the cleaning sponge on the base.
- Insert the cleaning pin holder into the base. (See illustration at right)

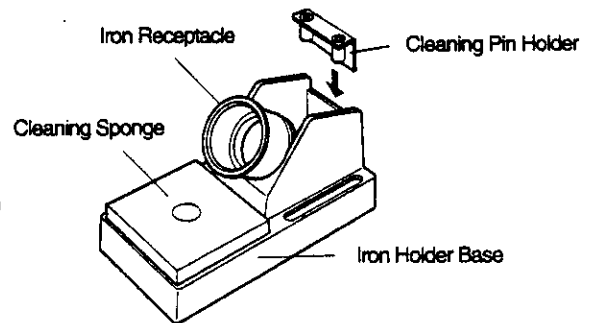

⚠ CAUTION : Use only a dampened and wrung cleaning sponge to clean the nozzle. Using a dry sponge will reduce the life of the nozzle.

Notes:

- The sponges are compressed. They will swell when moistened with water.
- The capillary sponge will absorb water from the reservoir and, by capillary action, transfer water to the cleaning sponge, thus keeping the cleaning sponge moist at all times.
- The cleaning sponge may be used by itself by dampening it, squeezing it dry, and placing it on the iron holder base. It is not necessary to use the capillary sponge or add water to the reservoir.

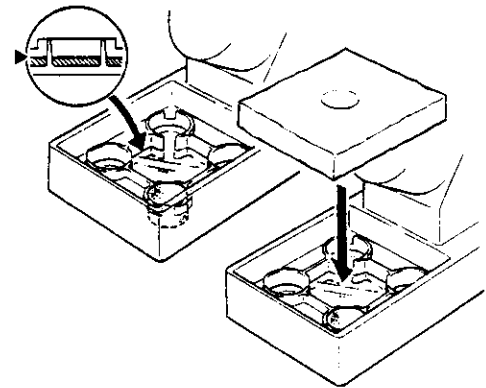

Assemble the Desoldering Iron

- Insert the filter pipe (w/filter holder/spring filter /ceramic paper filter (L)) into the housing.
- Push and turn clockwise the back holder.

Connect the Desoldering Iron to the Station

- Insert the 6-pin connecting plug into the receptacle on the station. Lock the plug by turning the plug's outer ring clockwise.
- Place the desoldering iron in the iron holder.
- Connect the hose to the vacuum outlet cap.

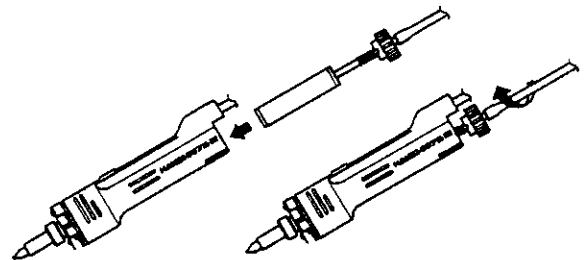

Plug the Station into a Power Source

- Plug the power cord into a grounded AC outlet.
- Turn the power switch to "ON".

After turning on the power, wait three (3) minutes before beginning desoldering operations.

Connect the Compressor (473)

1. Use filtered air to clean away any dust, oil and moisture.
2. With the button pressed and air flowing, adjust the regulator air pressure to 71 psi (5.0kgf/cm²).

Caution:

1. The absorption power of the unit will be reduced if adjustment is made while air is not flowing or if the tube is not measured as specified.
2. Do not set the regulator to pressures of 128 psi (9kgf/cm²) or higher while the button is not pressed, as such pressures can damage various parts of the station.

Set the Temperature

The temperature can be adjusted to between 662°F and 842°F with the temperature control knob. This unit has excellent thermal recovery, permitting it to operate at lower temperatures than conventional desoldering tools.

- The temperature can be more precisely set using a soldering iron thermometer. Adjust the temperature control knob until the measured temperature at the nozzle is the desired temperature.
- The temperature control knob can be secured by tightening the temperature control knob securing screw ("+" screw at the top of the unit).

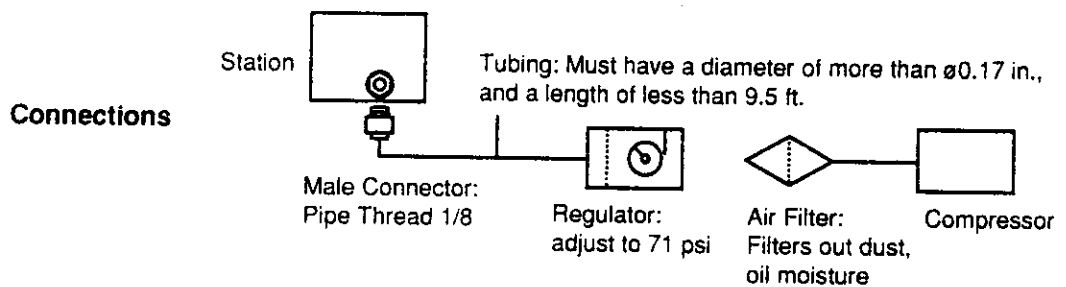

Desoldering

1. Apply the nozzle to the soldered lead and melt the solder.
2. Confirm that the solder is melted by placing the nozzle against the lead and carefully applying slight pressure to the lead. If the lead moves, the solder is melted. Never move the lead by force. If the lead does not move easily, the solder is not fully melted.
3. Extract the solder by pressing the button on the iron.
4. If solder remains, resolder the component.

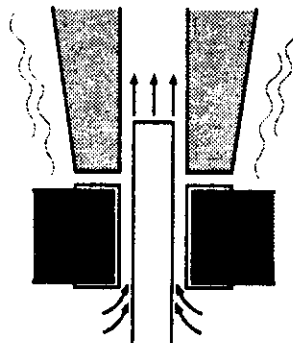

Extract the solder by slowly moving the lead back and forth with the tip of the nozzle.

Replacing the Nozzle

1. Remove the nut using the supplied spanner.
2. Disassemble the heating parts.
3. Replace the nozzle

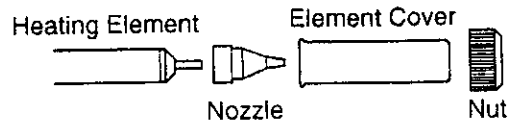

Replacing the Filters

1. Turn the back holder knob counterclockwise and pull out the filter pipe.
2. If there is solder in two-thirds of the spring filter, replace the filter.
3. If the ceramic paper filter is stiff with flux and solder, replace the filter.
4. Insert the spring filter into the filter pipe.
5. Insert the ceramic paper filter into the filter pipe.
6. Insert the back holder into the filter pipe.
7. Insert the filter pipe into the main body and secure it by turning the back holder knob clockwise.

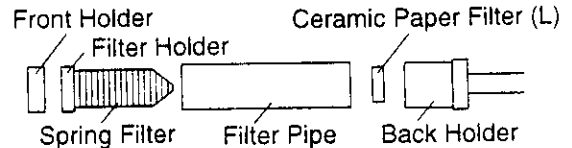

CAUTION:
Use the ceramic paper filter (L) for the filter pipe. Using of the ceramic paper filter (S) in the filter pipe may cause to break or the power to drop.

CAUTION:
Insert the Filter Holder into the wide end of the Spring Filter and push it firmly into place.

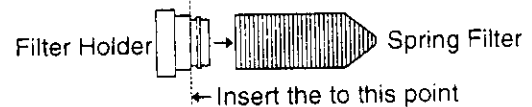

Replacing the Heating Element

The nominal resistance values of a working heating element are 9.2Ω between pins 1 and 3 (heating element), and 54Ω between pins 2 and 4 (sensor) at 23°C (73°F)—Fig. 4.

The heating element should be replaced if:

- The heater or sensor resistance is zero.
- The heater or sensor resistance is infinite.

If the heater resistance is less than 45, or greater than 65, or the sensor resistance is less than 8, or greater than 11, check the wiring in the desoldering iron.

1. Unplug the power cord.
2. Disassemble the heating parts.
3. Turn the back holder knob counterclockwise and pull out the filter pipe.
4. Remove the housing fastener (8). Fig. 1.
5. Remove the screws securing the housing (10) and the flange (3), (4). Fig. 2.
6. Remove the front holder (11). Fig. 2
7. Remove the screws (5), (6), (7) securing the heating element to the flange, and the screws (1), (2).
8. Desolder the heating element and sensor leads.
9. Secure a new heating element (24V–60W) to the flange with screws (5), (6), (7). Install the heater in such a way that the lead wires are oriented as in Fig. 3.
10. Install the front holder.
11. Resolder the heating element and sensor leads.
12. Reassemble the unit.
13. Recalibrate the temperature.

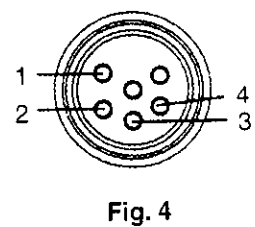
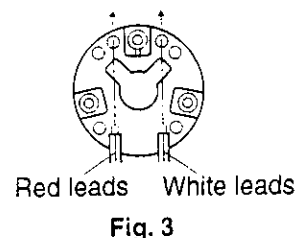
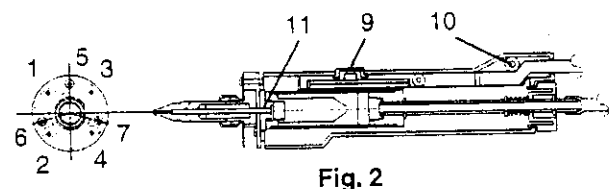
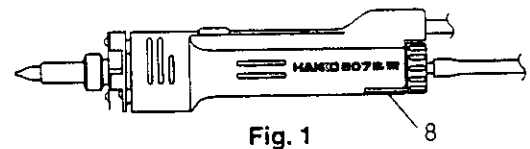

The resistance value of new heating elements varies, resulting in variations in operating temperature. It is necessary to recalibrate the temperature every time the heating element is replaced.

1. Set the temperature control knob to "1" and allow the iron to warm up for three (3) minutes.
2. Adjust the temperature calibrator ("CAL") until the nozzle temperature (measured with a tip thermometer) is 350°C (662°F).

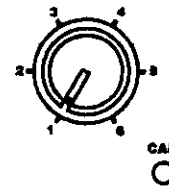

Maintenance

Properly maintained, the Hakko 472B/473 desoldering tool will provide years of good service. During many of the maintenance procedures, the desoldering iron will be extremely hot. Please wear gloves and work carefully.

Clean the Nozzle with the Nozzle Cleaning Pin

1. Turn the power switch to "ON" and let the (nozzle, heating element) heat up until the solder is melted.
2. Clean the hole of the nozzle with the nozzle cleaning pin.

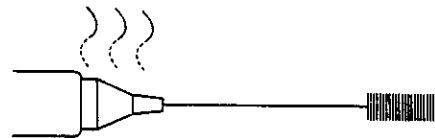

Clean the Nozzle with the Nozzle Cleaning Drill

1. Turn the power switch to "ON" and let the (nozzle, heating element) heat up until the solder is melted.
2. Turning the drill bit clockwise, insert it all the way into the nozzle.
3. Without turning the drill bit, pull it straight out from the nozzle.

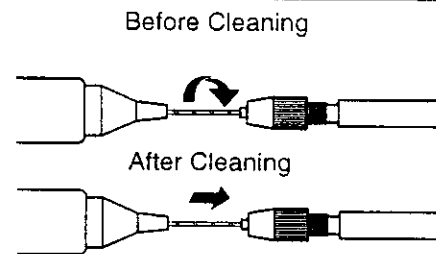

Clean the Hole in the Heating Element

1. Disassemble the heating element.
2. Turn the power switch to "ON" and let the (nozzle, heating element) heat up until the solder is melted.
3. Scrape away all accumulated oxidation from the hole in the heating element until the cleaning pin passes cleanly through the hole.

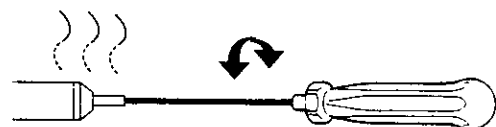

Cleaning the inside of the Filter Case

1. Remove the Ceramic Paper Filter and inspect it. If it is stiff with flux, replace it.
2. Apply silicone grease to the O-ring of the vacuum outlet retainer (472B/473) and to the packing of the filter retainer (472B). Securely tighten the vacuum outlet cap to prevent air leakage.

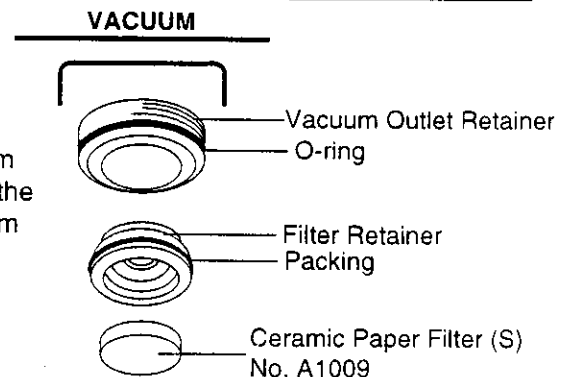

Clean the pump (472B)

1. Unplug the power cord.
2. Remove the rear panel and the cover.
3. Remove the pump head from each side of the pump.
4. Remove the valve plate and the fixing plate. If the fixing plate is difficult to remove, warm it with hot air. Never use excessive force to remove the plate as it is easily bent.
5. Using only isopropyl alcohol or denatured alcohol, remove any flux adhering to the plates.
6. If the exhaust filter is dirty, replace it.

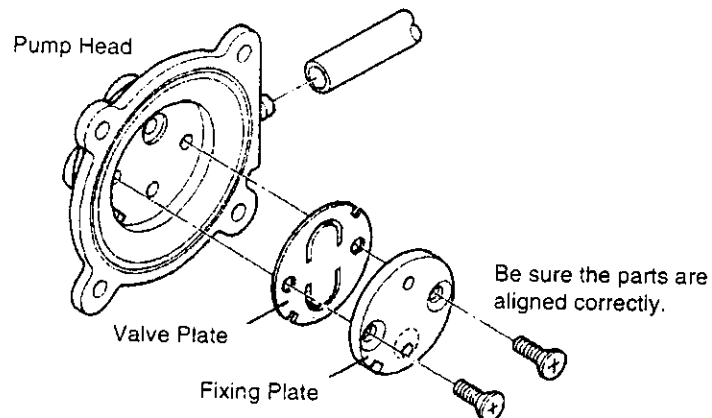
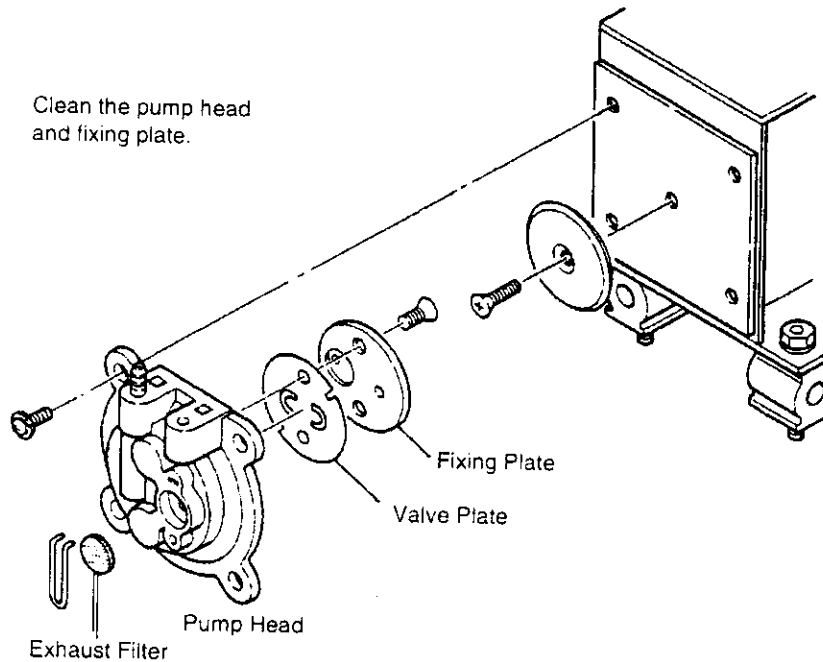
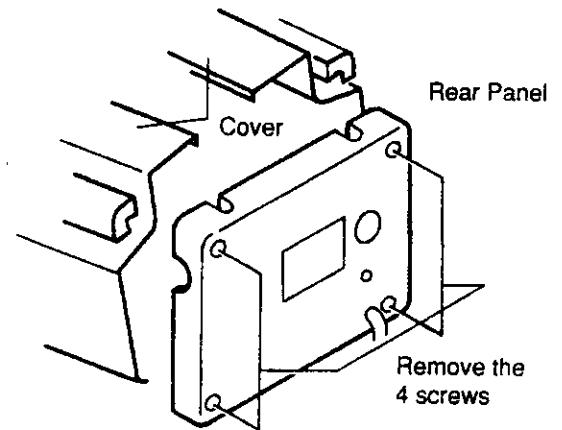

Disassemble the Ejector (473)

1. Remove the exhaust filter covering the ejector. If the filter is dirty, replace it.
2. Remove the ejector cover and inspect the noise filter (No. B1269). If the filter is dirty, replace it.
3. Remove the exhaust pipe and spacer inside the ejector. Pinch the tip of the exhaust pipe and pull firmly. Both the spacer and the exhaust pipe will come out together.

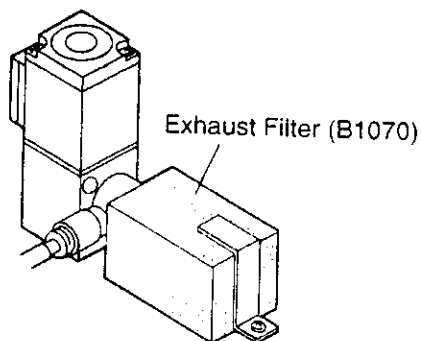

Clean the inside (473)

1. Clean the inside of the main body of the ejector, the tip of the nozzle and the surrounding area. Remove any dirt with a cotton swab soaked in alcohol.

Caution:

Do not use thinner as a cleaning agent.

2. Soak the exhaust pipe in alcohol and clean the inside of the pipe with a pipe cleaner or a brass brush.

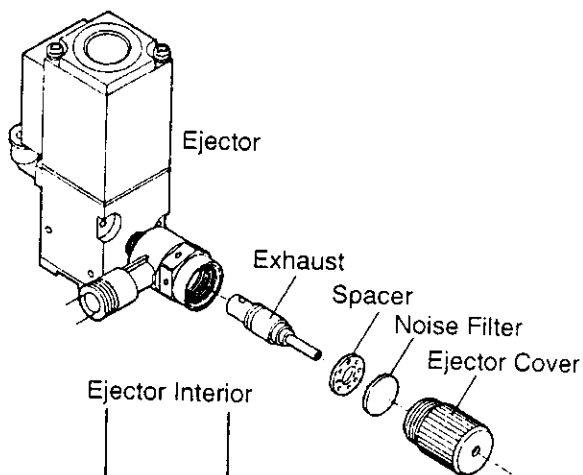

Reassemble the Ejector (473)

Follow the disassembly steps (above) in reverse order.

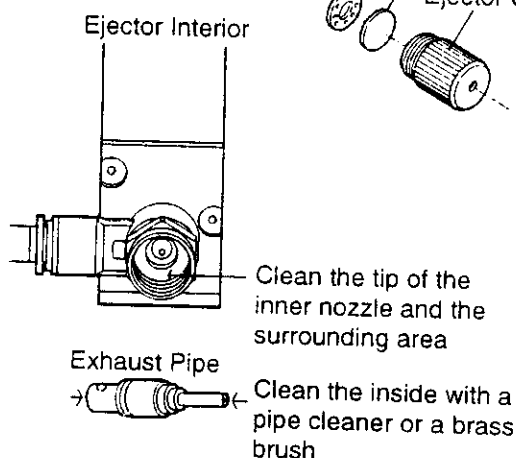

Troubleshooting Guide

Power lamp does not light up

- Is the power cord plugged in correctly?
- Is the fuse blown?

Pump does not operate

- Is the cord assembly properly connected?
- Is the nozzle or hole in the heating element clogged?

Solder is not being extracted

- Is the spring filter full of solder?
- Is the ceramic paper filter hardened?
- Is there a vacuum leak?

Nozzle does not heat up

- Is the desoldering iron cord assembly properly connected?

Hakko 472B Station

Note: Spare or repair parts do not include mounting screws, if they are not listed on the description. Screws must be ordered separately.

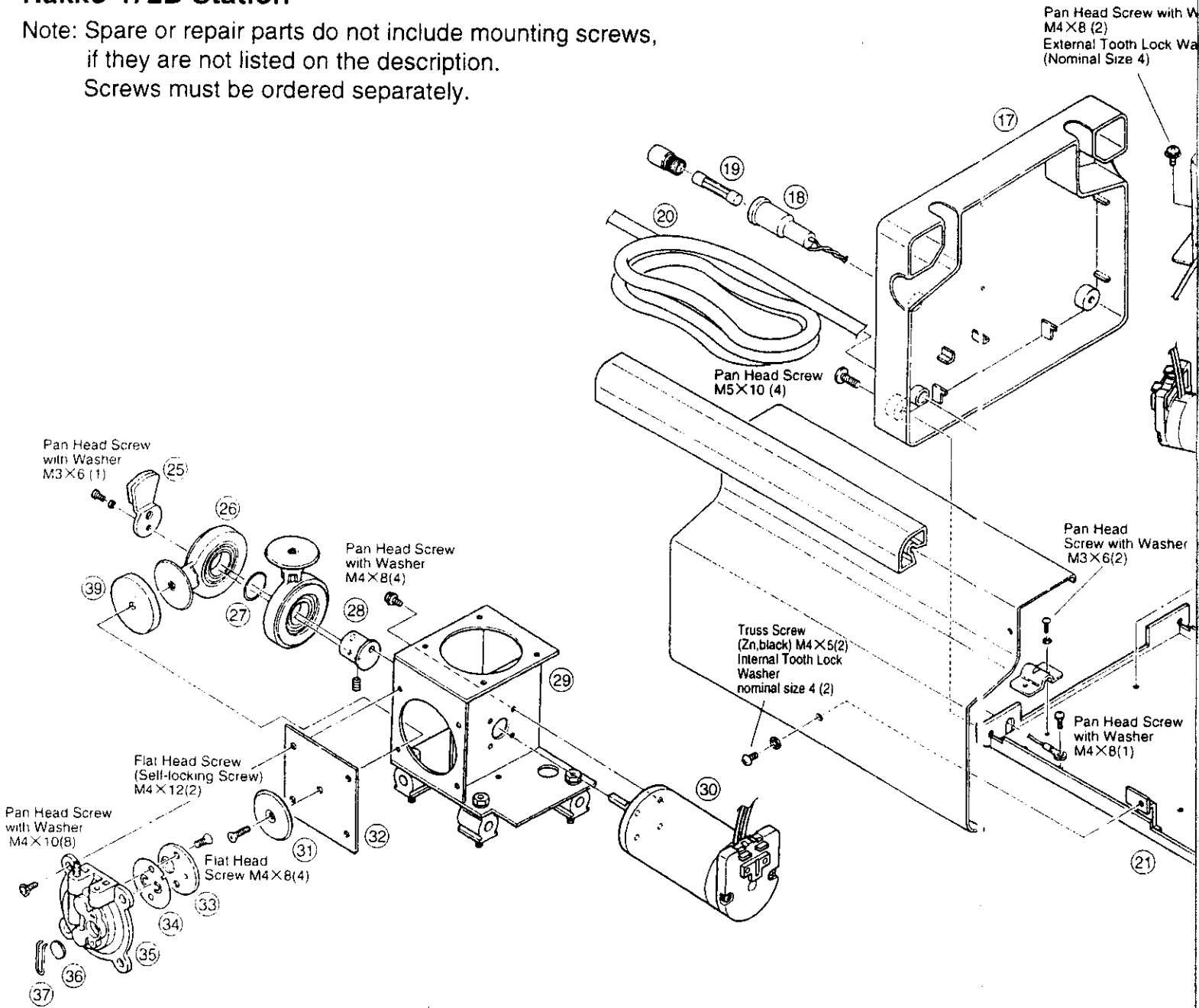

Item No.	Part No.	Part Name	Description
1	B1029	Vacuum Outlet Cap	
2	A1009	Ceramic Paper Filter (S)	10 pcs
3	B1063	Filter Retainer	
4	B1031	Vacuum Outlet Retainer	with O-ring (S20) with Screws
5	B1034	O-ring (S20)	
6	B1038	Cover for Securing Screw	set of 4
7	B1662	Receptacle	
8	B1028	Knob	with Screws
9	B2447	Front Panel	with Screws
10	B1093	Cover	one side

Item No.	Part No.	Part Name	Description
11	B1061	Handle	one side
12	B1044	Temp. Control Set Screw Clamp	with Screws
13	B2448	P.W.B.	with potentiometer
14	B2063	Hose Assembly	
15	B2078	Transformer	120-24V
16	B2444	Pump Assembly	
17	B2449	Rear Panel	with Rating Seal
18	B1041	Fuse Holder	without Fuse
19	B1275	Fuse	250V-2A (U)/120V

Item No.	Part No.	Part Name	Description
20	B2068	Hose Assembly	
21	B2445	Front Panel	
22	B1037	Filter Retainer	
23	B1084	Receptacle	
24	B1078	Front Panel	
25	B1053	Filter Retainer	
26	B1312	Filter Retainer	

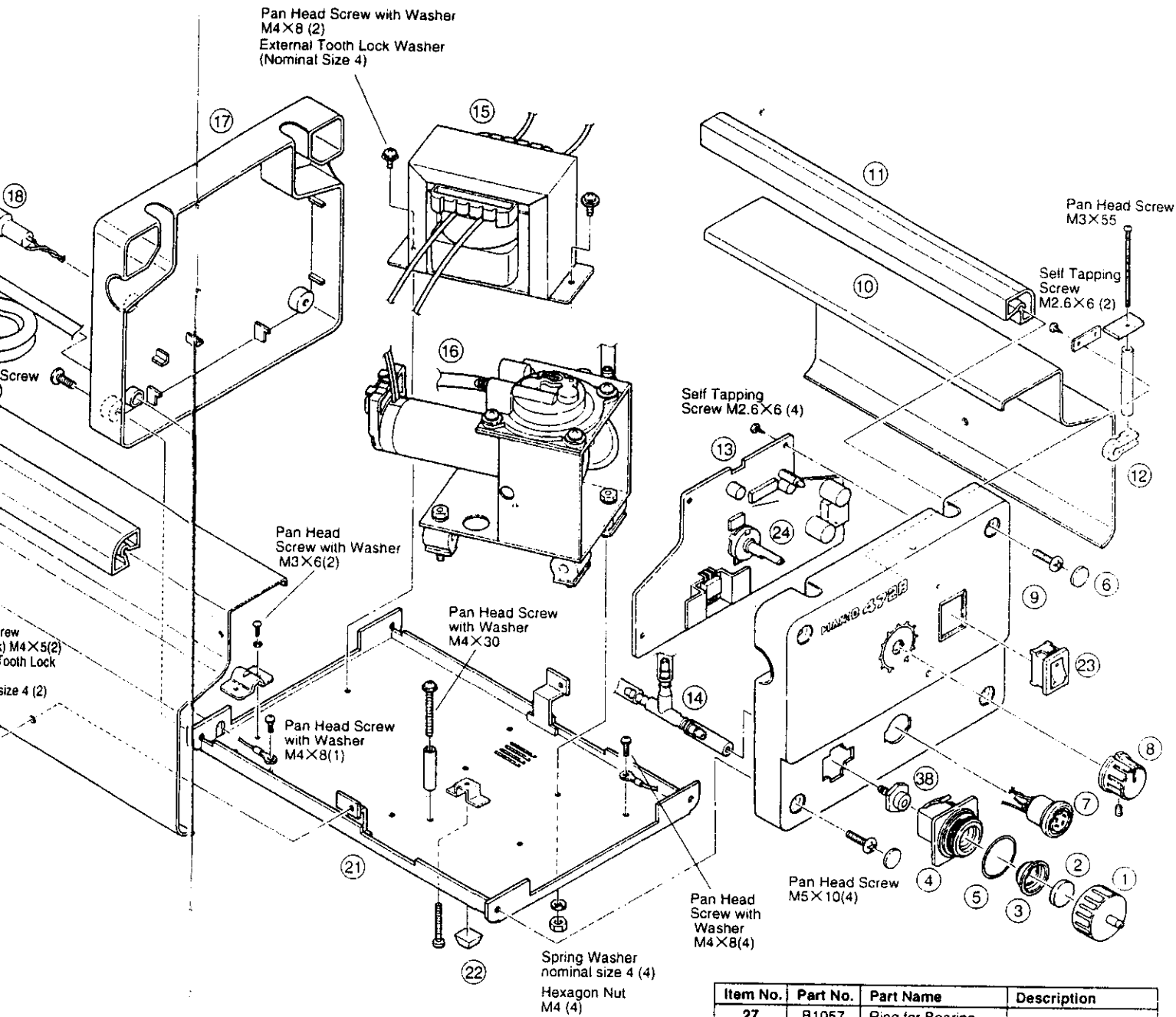

Description
side
lamp with Screws
potentiometer
24V
Rating Seal
out Fuse
1-2A (U)/120V

Item No.	Part No.	Part Name	Description
20	B2068	Power Cord	3 Core & American Plug
21	B2445	Chassis	
22	B1037	Rubber Stopper	set of 4
23	B1084	Switch	
24	B1078	Potentiometer	
25	B1053	Balance Weight	
26	B1312	Crank	with Bearing

Item No.	Part No.	Part Name	Description
27	B1057	Ring for Bearing	
28	B2060	Crank Shaft	with Screw
29	B2059	Pump Frame	
30	B2058	Motor	
31	B2085	Diaphragm Setting Plate	
32	A1013	Diaphragm	set of 2 with Screws
33	B1056	Fixing Plate	
34	A1014	Valve Plate	set of 2
35	B1050	Pump Head	with Screws
36	B1059	Exhaust Filter	set of 2
37	B1313	Filter Retaining Pin	
38	B1064	Filter Case Joint	
39	B2506	Damper	set of 2

Hakko 473 Station

Note: Spare or repair parts do not include mounting screws, if they are not listed on the description. Screws must be ordered separately.

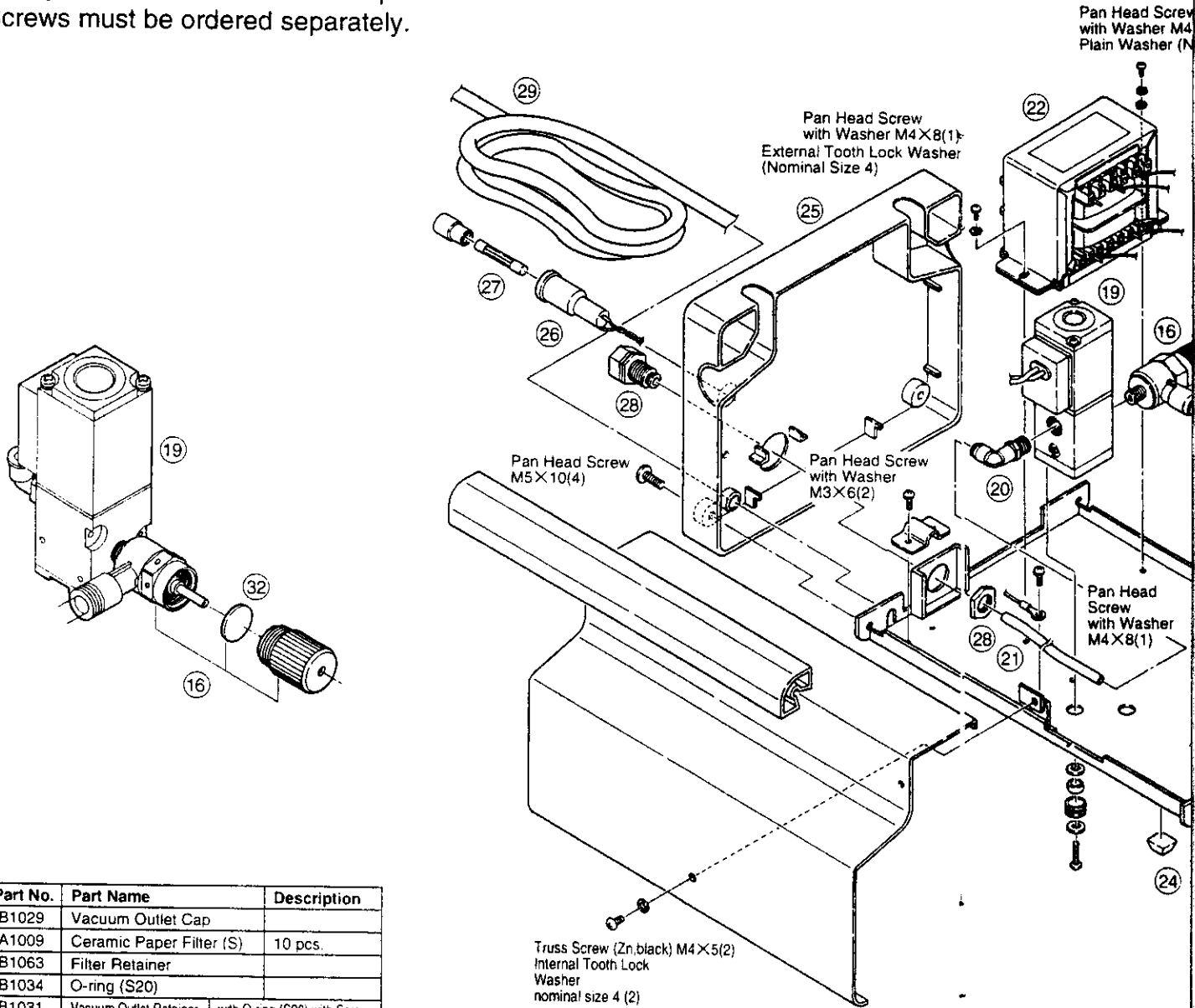

Item No.	Part No.	Part Name	Description
1	B1029	Vacuum Outlet Cap	
2	A1009	Ceramic Paper Filter (S)	10 pcs.
3	B1063	Filter Retainer	
4	B1034	O-ring (S20)	
5	B1031	Vacuum Outlet Retainer	with O-ring (S20) with Screws
6	B1064	Filter Case Joint	
7	B1667	Front Panel	
8	B1038	Cover for Securing Screw	set of 4
9	B1662	Receptacle	
10	B1028	Knob	
11	B1093	Cover	one side
12	B1061	Handle	one side
13	B1044	Temp. Control Set Screw Clamp	
14	B1073	Joint Hose	
15	B1669	P.W.B.	
16	B1069	Ejector	

Item No.	Part No.	Part Name	Description
17	B1070	Exhaust Filter	
18	B1071	Exhaust Filter Retaining Clip	
19	B1074	Solenoid Valve	with Screws
20	B1075	Elbow Joint	
21	B1076	Pressure Hose	
22	B1103	Transformer	
23	B1067	Chassis	
24	B1037	Rubber Stopper	

Item No.	Part No.
25	B1668
26	B1041
27	B1275
28	B1127
29	B1104
30	B1078
31	B1084
32	B1269

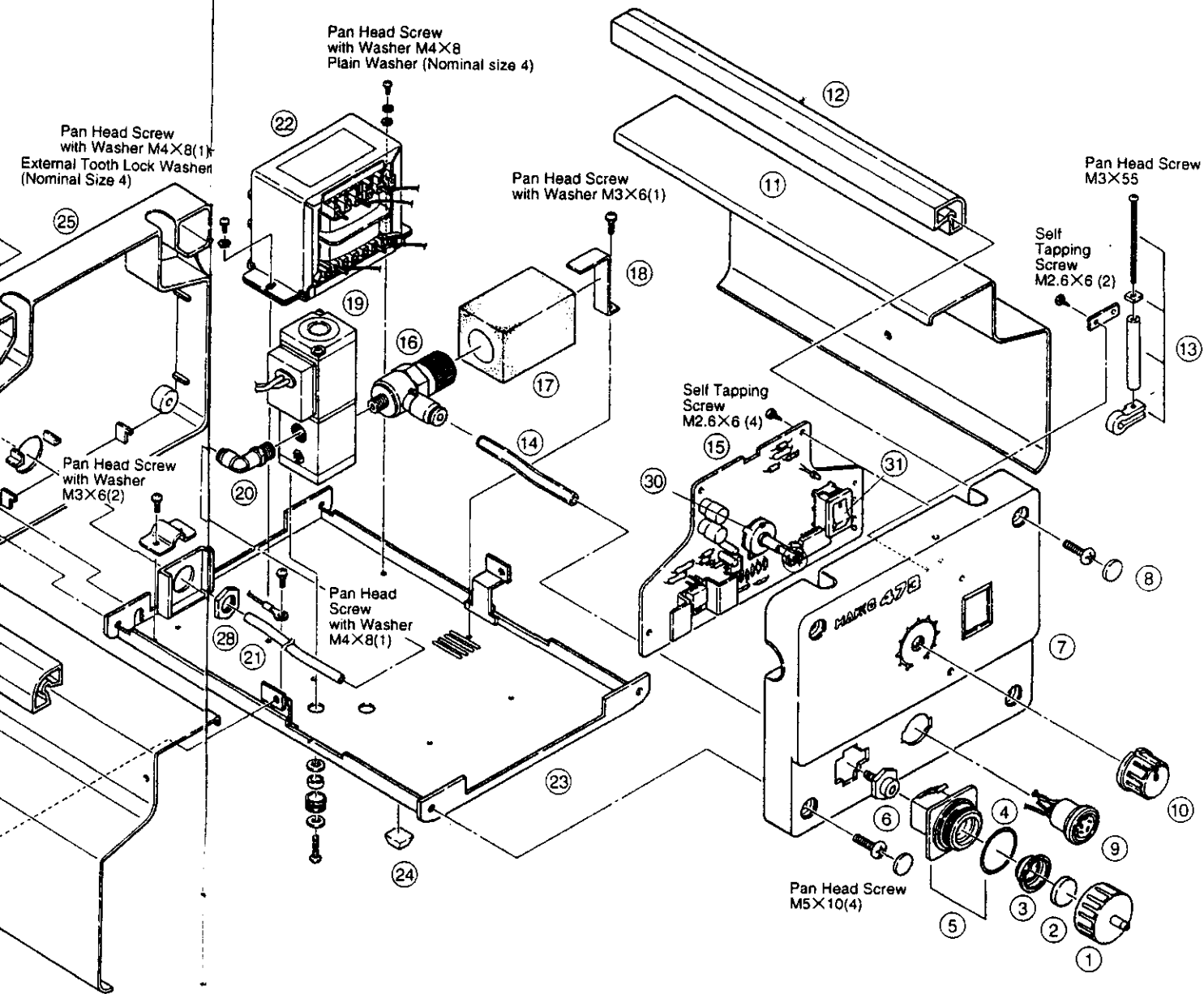

Description
lip
with Screws

Item No.	Part No.	Part Name	Description
25	B1668	Rear Panel	with Rating Seal
26	B1041	Fuse Holder	without Fuse
27	B1275	Fuse	250V-2A (U)
28	B1127	Female Connector	
29	B1104	Power Cord	
30	B1078	Potentiometer	
31	B1084	Switch	
32	B1269	Noise Filter	

Parts List

Hakko 807 Desoldering Iron

Note: Spare or repair parts do not include mounting screws, if they are not listed on the description. Screws must be ordered separately.

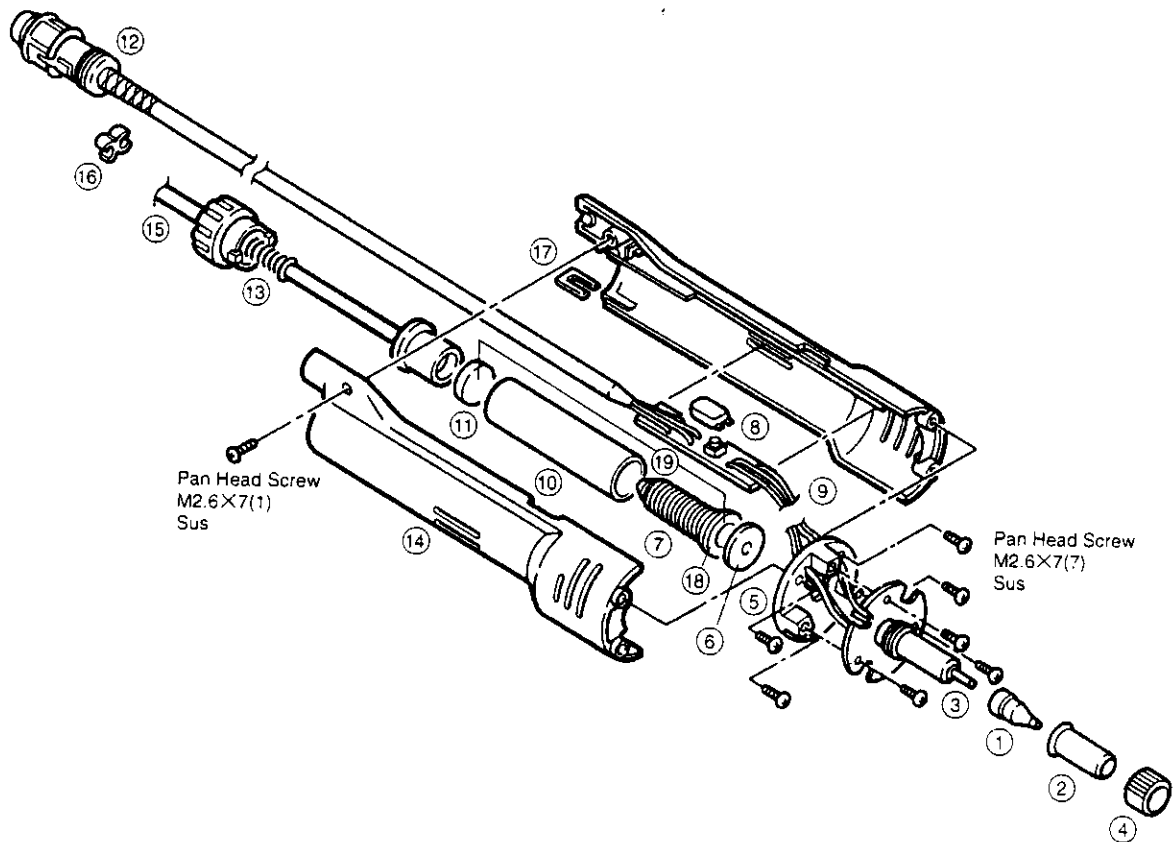

Item No.	Part No.	Part Name	Description
1		Nozzle/See Replacement Parts	
2	B1653	Element Cover	
3	A1174	Heating Element	24V-60W
4	B1015	Nut	
5	B1654	Flange	
6	A1304	Front Holder	
7	A1030	Spring Filter	Set of 10
8	B1655	Button	
9	B1656	Board w / Switch	
10	B1916	Filter Pipe	
11	A1033	Ceramic Paper Filter-L	Set of 10
12	B1657	Cord Asse'y	
13	B1917	Back Holder Asse'y	
14	B1659	Housing	with a screw & Fastener
15	B1023	Hose / E.S.D.	
16	B1024	Cord Holder	Set of 4
17	B1660	Housing Fastener	
18	B1915	Filter Holder	
19	B2517	Filter Pipe with Filter Holder & Filters	

Parts List

Iron Holder

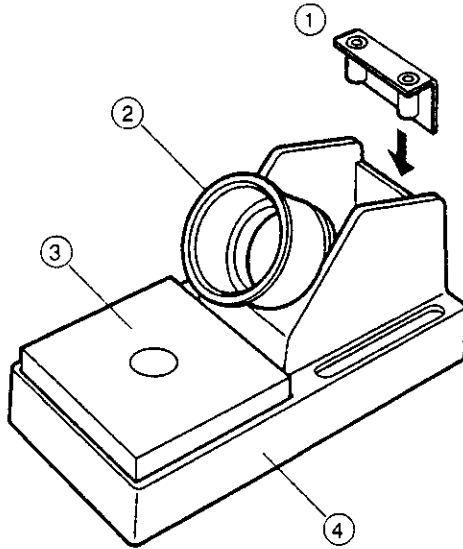

Item No.	Part No.	Part Name
1	B2312	Cleaning Pin Holder
2	B2311	Iron Receptacle
3	A1042	Cleaning Sponge
4	B2019	Iron Holder Base

Replacement Parts

Part No.	Part Name / Specification
A1002	Nozzle S $\phi 0.8$ mm (0.03 in)
A1003	Nozzle S $\phi 1.0$ mm (0.04 in)
A1004	Nozzle $\phi 0.8$ mm (0.03 in)
A1005	Nozzle $\phi 1.0$ mm (0.04 in)
A1006	Nozzle $\phi 1.3$ mm (0.05 in)
A1007	Nozzle $\phi 1.6$ mm (0.06 in)
B1215	Cleaning Pin for Heating Element
B1086	Cleaning Pin for $\phi 0.8$ mm (0.03 in) Nozzle
B1087	Cleaning Pin for $\phi 1.0$ mm (0.04 in) Nozzle
B1088	Cleaning Pin for $\phi 1.3$ mm (0.05 in) Nozzle
B1089	Cleaning Pin for $\phi 1.6$ mm (0.06 in) Nozzle
B1302	Cleaning Drill for $\phi 0.8$ mm (0.03 in) Nozzle
B1303	Cleaning Drill for $\phi 1.0$ mm (0.04 in) Nozzle
B1304	Cleaning Drill for $\phi 1.3$ mm (0.05 in) Nozzle
B1305	Cleaning Drill for $\phi 1.6$ mm (0.06 in) Nozzle
B1670	Cleaning Brush
A1028	Silicone Grease
B2100	Spanner
C1316	Iron Holder for 807

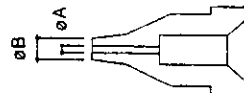

Part No.	ϕA	ϕB
A 1002	0.8 mm (0.03 in)	1.8 mm (0.07 in)
A 1003	1.0 mm (0.04 in)	2.0 mm (0.08 in)

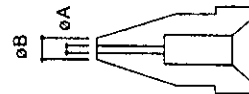

Part No.	ϕA	ϕB
A 1004	0.8 mm (0.03 in)	2.3 mm (0.09 in)
A 1005	1.0 mm (0.04 in)	2.5 mm (0.1 in)
A 1006	1.3 mm (0.05 in)	3.0 mm (0.12 in)
A 1007	1.6 mm (0.06 in)	3.0 mm (0.12 in)

Wiring Diagram

Hakko 472B

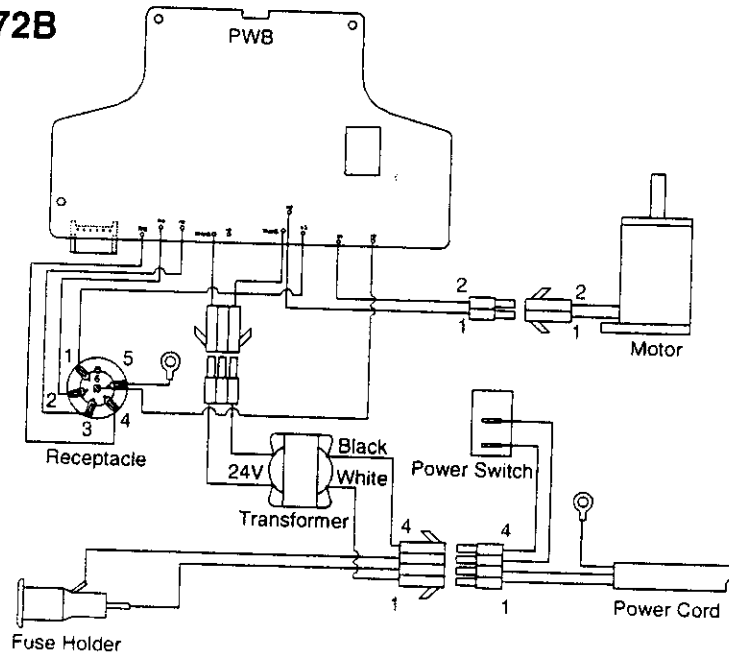

Hakko 473

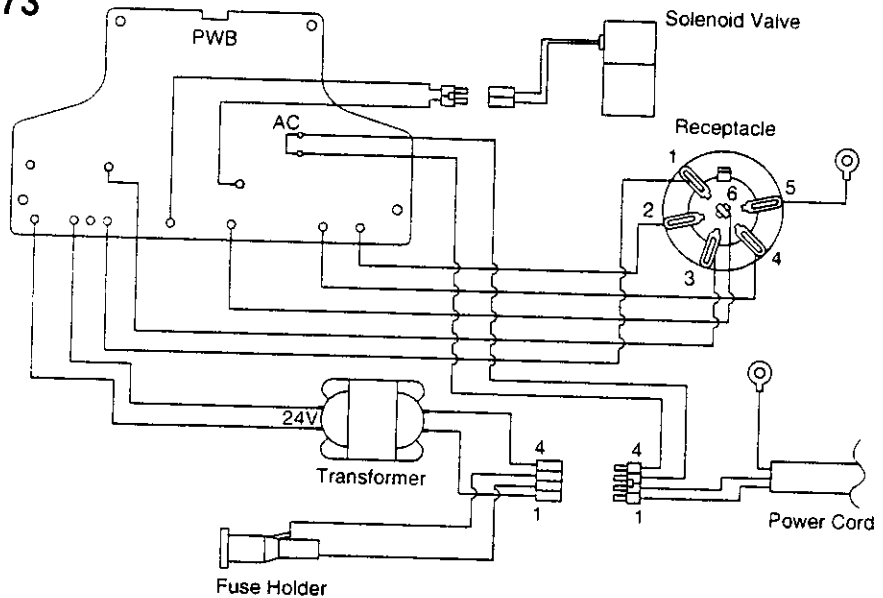

HAKKO CORPORATION

HEAD OFFICE

4-5, SHIOKUSA 2-CHOME, NANIWA-KU, OSAKA, 556-0024 JAPAN

TEL: +81-6-6561-3225 FAX: +81-6-6561-8466

AMERICAN HAKKO PRODUCTS, INC.

25072 ANZA DR. SANTA CLARITA, CA 91355, U.S.A.

TEL: (661) 294-0090 FAX: (661) 294-0096

Toll Free (800)88-HAKKO www.hakkousa.com