

INSTRUCTION MANUAL

2301-20

HUMIDITY MODULE

HIOKI E. E. CORPORATION

Contents

Introduction	1
Inspection.....	1
Safety Notes	2
Notes on Use	5
Chapter 1 Overview	11
1.1 Product Overview	11
1.2 Major Features	12
1.3 Name and Function of the Parts.....	15
1.4 Dimension Diagrams	17
Chapter 2 Settings	19
2.1 Setting the Module ID	19
Chapter 3 Preparations	21
3.1 Installing the Module	21
3.1.1 Installing the Module Base	21
3.1.2 Mounting a Module on the Module Base	21
3.2 Connecting Input/Output Cables	22
3.2.1 Connecting Sensor Cables to the Terminal block.....	22
3.2.2 Connecting Cables to the ALARM Terminal (Alarm output)	24
3.2.3 The Location of the Input/Output Cable.....	25

Chapter 4	Others	26
<hr/>		
4.1	Alarm output.....	26
4.1.1	Output Rating.....	26
4.1.2	Internal Circuit.....	27
4.2	Insulation of Internal Circuit.....	29
Chapter 5	Specifications	31
<hr/>		
5.1	Basic Specifications	31
5.2	Function Specifications	32
5.3	General Specifications	33
5.4	9764 HUMIDITY SENSOR Specifications	34
Chapter 6	Maintenance and Service	37
<hr/>		
6.1	Cleaning	37
6.2	Service	37

Introduction

Thank you for purchasing the HIOKI “Model 2301-20 HUMIDITY MODULE”. To obtain maximum performance from the instrument, please read this manual first, and keep it handy for future reference.

Inspection

When you receive the instrument, inspect it carefully to ensure that no damage occurred during shipping. In particular, check the panel switches, and connectors. If damage is evident, or if it fails to operate according to the specifications, contact your dealer or Hioki representative.

Accessories

Instruction manual	1
Ferrite clamp.....	1
Terminal block.....	3

Option

9764 HUMIDIDTY SENSOR

Safety Notes





This instrument is designed to comply with IEC 61010 Safety Standards, and has been thoroughly tested for safety prior to shipment. However, mishandling during use could result in injury or death, as well as damage to the instrument. Be certain that you understand the instructions and precautions in the manual before use. We disclaim any responsibility for accidents or injuries not resulting directly from instrument defects.

This manual contains information and warnings essential for safe operation of the instrument and for maintaining it in safe operating condition. Before using it, be sure to carefully read the following safety precautions.

Safety Symbols



In the manual, the  symbol indicates particularly important information that the user should read before using the instrument.

The  symbol printed on the instrument indicates that the user should refer to a corresponding topic in the manual (marked with the ) before using the relevant function.



Indicates DC (Direct Current).

The following symbols in this manual indicate the relative importance of cautions and warnings.



Indicates that incorrect operation presents an extreme hazard that could result in serious injury or death to the user.



Indicates that incorrect operation presents a significant hazard that could result in serious injury or death to the user.



Indicates that incorrect operation presents a possibility of injury to the user or damage to the instrument.



Indicates advisory items related to performance or correct operation of the instrument.

Other Symbols



Indicates the prohibited action.



Indicates the reference.

Measurement categories (Overvoltage categories)

This instrument complies with CAT I safety requirements. To ensure safe operation of measurement instruments, IEC 61010 establishes safety standards for various electrical environments, categorized as CAT I to CAT IV, and called measurement categories. These are defined as follows.

- CAT I Secondary electrical circuits connected to an AC electrical outlet through a transformer or similar instrument.
- CAT II Primary electrical circuits in equipment connected to an AC electrical outlet by a power cord (portable tools, household appliances, etc.)
- CAT III Primary electrical circuits of heavy equipment (fixed installations) connected directly to the distribution panel, and feeders from the distribution panel to outlets.
- CAT IV The circuit from the service drop to the service entrance, and to the power meter and primary overcurrent protection instrument (distribution panel).

Higher-numbered categories correspond to electrical environments with greater momentary energy. So a measurement instrument designed for CAT III environments can endure greater momentary energy than a instrument designed for CAT II.

Using a measurement instrument in an environment designated with a higher-numbered category than that for which the instrument is rated could result in a severe accident, and must be carefully avoided.

Never use a CAT I measuring instrument in CAT II, III, or IV environments.

The measurement categories comply with the Overvoltage Categories of the IEC60664 Standards.

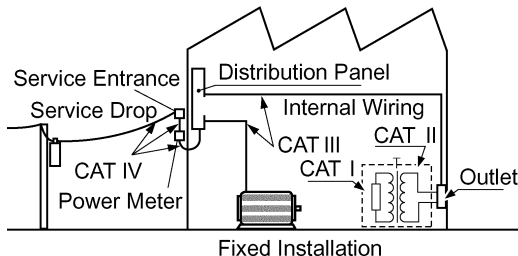

Notes on Use



Follow these precautions to ensure safe operation and to obtain the full benefits of the various functions.

CAUTION

Do not allow the instrument to get wet.



Operation and Installation environment.

This instrument should be installed and operated indoors only, between 0 and 50°C (32 to 122°F) and 80% RH or less.

Do not allow the instrument to get wet, and do not take measurements with wet hands.

The instrument may be damaged.



Corrosive or combustible gases

Do not use the instrument where it may be exposed to corrosive or combustible gases.

The instrument may be damaged.

Do not use the instrument near a source of strong electromagnetic radiation, or near a highly electrically charged object.

These may cause a malfunction.

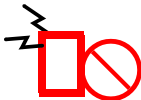

Electromagnetic radiation or highly electrical charged object

This instrument is not designed to be entirely water- or dust-proof.

Do not use it in an especially dusty environment, nor where it might be splashed with liquid. This may cause damage.

When the module is used in a dusty environment, place it in a dustproof case and take measures to ensure heat dissipation.

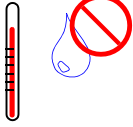
CAUTION

Temperature or
humidity

Do not store or use the instrument where it could be exposed to direct sunlight, high temperature or humidity, or condensation.

Under such conditions, the instrument may be damaged and insulation may deteriorate so that it no longer meets specifications.



Dust

To avoid damage to the instrument, protect it from physical shock when transporting and handling.

Be especially careful to avoid physical shock from dropping.



Direct sunlight

Do not obstruct the ventilation holes.

Ventilation holes for heat radiation are provided on the top and rear panels of the instrument. Leave sufficient space around the ventilation holes and install the instrument with the holes unobstructed. Installation of the instrument with the ventilation holes obstructed may cause a malfunction or fire.

When using the instrument in the case, drill ventilation holes.

Drill ventilation holes or install a ventilation fan to prevent heat buildup.

Use the 9764 HUMIDITY SENSOR

To avoid damaging the 2301-20, only connect the 9764 HUMIDITY SENSOR to the TEMP and HUM terminals. Moreover, do not input other signals to these terminals.

Wiring

WARNING

- A qualified electrician shall perform the wiring to prevent electric shock.
- Avoid live-line electrical work to prevent electric shock and accidents due to short-circuiting.
- When tightening the screws, confirm that all screws are securely tightened. A loose screw may result in module errors, fire, or electric shock.
- Tighten the screws within the specified torque. Excessive torque may damage the terminals. Inadequate torque may result in module errors, fire, or electric shock.
- Ensure that the power supply module and input are OFF until all wiring work is finished. This will prevent module trouble and electric shock.
- Ensure that the power supply module and input are OFF when connecting or disconnecting the module to the system. This will prevent electric shock, errors, and malfunction.
- Avoid using an unused terminal for relaying or any other purpose to prevent electric shock, errors, and malfunction.

 CAUTION

-
- Connect the module to a power source that matches the rating in order to prevent fire.
 - Ensure that the power supply, input, and output are correctly wired according to the wiring diagram. (See the chapter on "Preparations" in the instructions manual for each module.) This will prevent fire, malfunction, and errors.
 - Use cables of the proper sizes for the rated current. This will prevent entire system errors and fire resulting from broken wire.
 - Use crimp connectors suitable for the cable sizes. This will prevent module errors and fire due to broken wires.
 - If power supply noise poses a problem, use of a noise filter is recommended.
 - When the power and signal lines may be subject to a lightning-induced surge, install a lightning arrester between another instrument or module connected to this module and line to protect the system.
 - Avoid stepping on or pinching cables, which could damage the cable insulation.
 - Keep the cables well away from heat sources, as bare conductors could be exposed if the insulation melts.
-

9764 HUMIDIDTY SENSOR

CAUTION

- If the sensor is used or stored outside the operating or storage ranges, sensor accuracy may be adversely affected and you may not get accurate measurements even within the one-year guaranteed period of accuracy.
 - Hioki is not liable for any problems caused by sensor use or storage outside the operating or storage ranges.
 - When not using the 9764 HUMIDIDTY SENSOR, seal it in a plastic bag and store it in a cool, dark place.
 - Be careful to avoid condensation on the sensor. If condensation occurs, you may not get accurate measurements. Condensation is likely to occur when the sensor is subject to rapid changes in temperature.
-

Preliminary Checks

WARNING

Before using the instrument, make sure that the insulation on the cables is undamaged and that no bare conductors are improperly exposed. Using the product in such conditions could cause an electric shock, so contact your dealer or Hioki representative for repair.

Before using the instrument the first time, verify that it operates normally to ensure that no damage occurred during storage or shipping. If you find any damage, contact your dealer or Hioki representative.

Overview

Chapter 1

1.1 Product Overview

- The 2301-20 is a measurement module of Hioki "Smart Site" (remote measurement system).
- This module measures and records temperature and humidity at regular intervals.
- The 2301-20 is used with the power supply module, communications module, and module base.

Number of measurement channels	Temperature 1 CH + Humidity 1 CH
Measurement range	-40.0 to 85.0°C, 0.0 to 100.0%RH



(Conceptual image)

1.2 Major Features

- ◆ The recording interval is selectable from 1 second to 60 minutes.
- ◆ The maximum, minimum, and average measurements during the recording interval can be recorded (with sampling once a second).
- ◆ The module has an alarm output terminal.
- ◆ The capacitive humidity sensor for this module has the following features relating to humidity measurement:
 - Stable characteristics
 - Wide measurement range
 - Long service life
 - Quick response
 - Resistance to condensation

Rough Estimate of Storable Data Quantity and Time

Action at memory full:

Continue recording (Endless)

	Recording Mode		
	Instantaneous Value	MAX/MIN/AVE	Instantaneous Value + MAX/MIN/AVE
Quantity of storable data	26000	13000	10000
Recording interval			
1 sec.	7.5 hours	3.5 hours	2.5 hours
2 sec.	14.5 hours	7 hours	5.5 hours
5 sec.	1.5 days	18 hours	14.5 hours
10 sec.	3 days	1.5 days	1 day
15 sec.	4.5 days	2 days	1.5 days
20 sec.	6 days	3 days	2 days
30 sec.	9 days	4.5 days	3.5 days
1 min.	18 days	9 days	7 days
2 min.	36 days	18 days	14 days
5 min.	92 days	46 days	36 days
10 min.	184 days	92 days	73 days
15 min.	277 days	138 days	110 days
20 min.	369 days	184 days	147 days
30 min.	554 days	277 days	221 days
60 min.	1109 days	554 days	443 days

NOTE

When the alarm log is ON, the higher the number of alarms generated, the smaller the recording period. (Approx. 1 of the data per alarm)

Action at memory full:

Stop recording (Memory full stop)

	Recording Mode		
	Instantaneous Value	MAX/MIN/AVE	Instantaneous Value + MAX/MIN/AVE
Quantity of storable data	30000	15000	12000
Recording interval			
1 sec.	8.5 hours	4 hours	3 hours
2 sec.	17 hours	8.5 hours	6.5 hours
5 sec.	1.5 days	21 hours	17 hours
10 sec.	3.5 days	1.5 days	1.5 days
15 sec.	5 days	2.5 days	2 days
20 sec.	7 days	3.5 days	2.5 days
30 sec.	10 days	5 days	4 days
1 min.	21 days	10 days	8 days
2 min.	42 days	21 days	17 days
5 min.	106 days	53 days	42 days
10 min.	213 days	106 days	85 days
15 min.	319 days	159 days	127 days
20 min.	426 days	213 days	170 days
30 min.	639 days	319 days	255 days
60 min.	1279 days	639 days	511 days

NOTE

When the alarm log is ON, the higher the number of alarms generated, the smaller the recording period. (Approx. 1 of the data per alarm)

1.3 Name and Function of the Parts

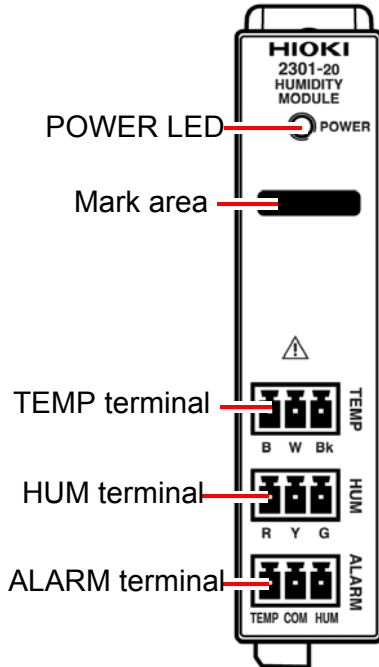
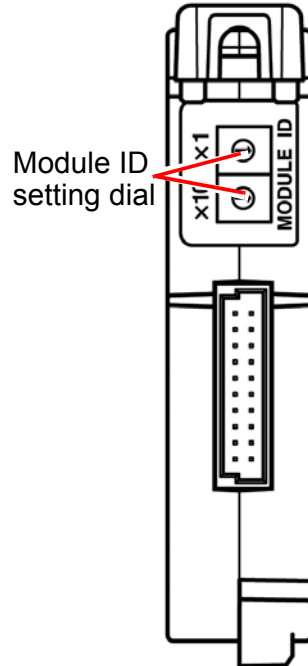
**Front****Back**

POWER LED	<p>Goes on or flashes when power is supplied to the module. Remains on, flashes, or changes to another color according to the state of the module.</p> <p>POWER LED indication</p> <p>Lit in green : Data being recorded. Flashing in green : Standing by. Lit in yellow : Alarm output. Flashing in yellow : Overrange detected. Lit in red : Non-recoverable error occurred. ^{*1} Flashing in red : Recoverable error occurred. ^{*2}</p>
Mark area	<p>Use this area to make a note of the object to measure or the module ID. Use an ink pen, since pencil lead may rub off.</p>
TEMP terminal	<p>Connect the temperature sensor to this terminal.</p>
HUM terminal	<p>Connect the humidity sensor to this terminal.</p>
ALARM terminal	<p>Connect the alarm output cable to this terminal.</p>
Module ID setting dial	<p>Use the dial to set the module's identification No.</p>

*1: The module needs repair. Contact your vendor (agent) or nearest Hioki office.

*2: The same module ID may be used by another module.

1.4 Dimension Diagrams

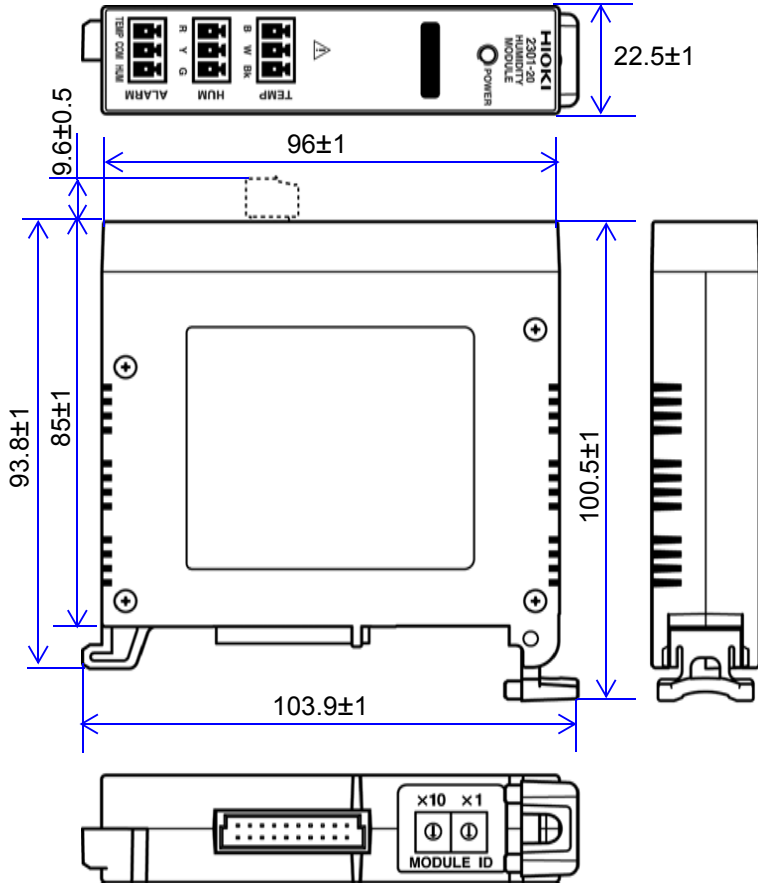

(Unit: mm)

Settings

Chapter 2

2.1 Setting the Module ID

You can connect up to 63 measurement modules to one communications module.

Setting Procedure

Use the module ID setting dial to set the ID No. of the module to a number from 01 and to 63. (You cannot set a number other than the above.)

NOTE

- Ensure that the set ID is not used for any other module connected to the same communications module.
- The ID numbers of modules need not be consecutive.
- Setting the ID to 99, then turning on the power resets all internal settings to the defaults.
- The module ID and COM ID are not related and can be set independently.

Preparations

Chapter 3

3.1 Installing the Module

3.1.1 Installing the Module Base



CAUTION Do not mount the module base on the ceiling where it may fall off.

Fasten the module base to a DIN rail or the wall according to the procedure described in the 2391 or 2392 series MODULE BASE instruction manual.

3.1.2 Mounting a Module on the Module Base

Mount a module on the module base as shown below. Ensure that the lever clicks.

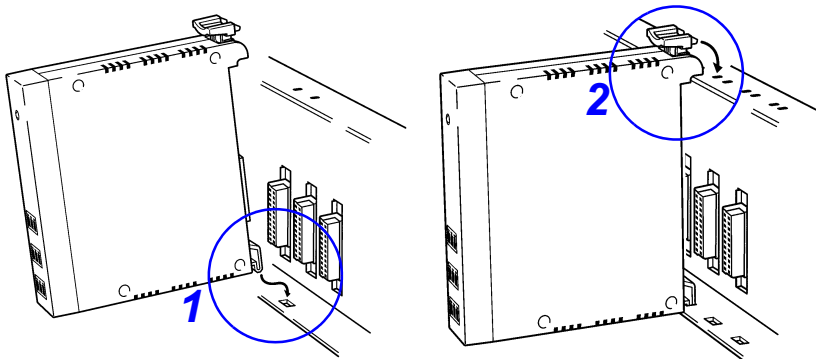

3.2 Connecting Input/Output Cables

3.2.1 Connecting Sensor Cables to the Terminal block

CAUTION

- The TEMP terminal and HUM terminal are not insulated from each other. Avoid short-circuiting.
- Be sure to connect the cables to matching connectors to prevent damage to the module or sensor.

Connect the 9764 HUMIDITY SENSOR to the module by following the procedure below.

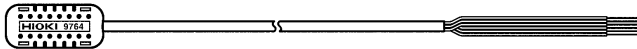

1. Use a flat blade screwdriver to loosen the screws on the terminal block.
2. Insert a cable into the terminal block, then tighten the screws (at a tightening torque of 0.25 N•m).

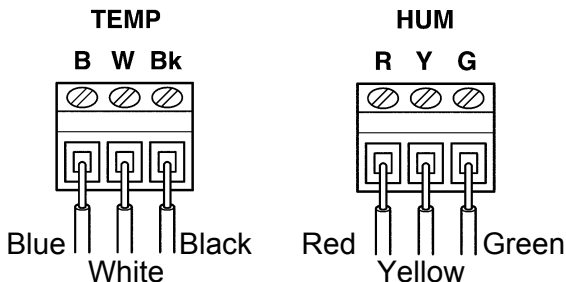

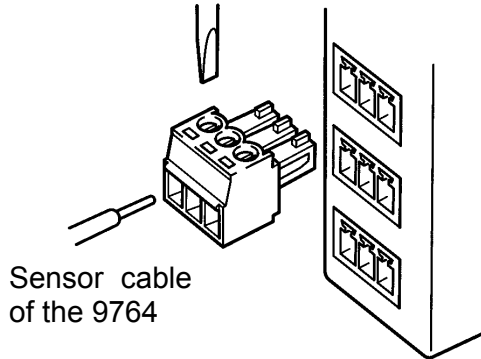
**NOTE**

- In case of external noise, wind the cable around the ferrite clamp supplied as an accessory as shown below.

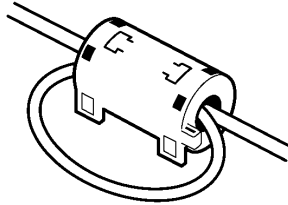

- Note that measurement may be adversely affected by external noise or the electromagnetic environment when using a cable longer than 3 meters.

3.2.2 Connecting Cables to the ALARM Terminal (Alarm output)

1. Use a flat blade screwdriver to loosen the screws on the terminal block.
2. Insert a cable for alarm output into the terminal block, then tighten the screws (at a tightening torque of 0.25 N•m).
3. Connect the terminal block to the ALARM terminal.

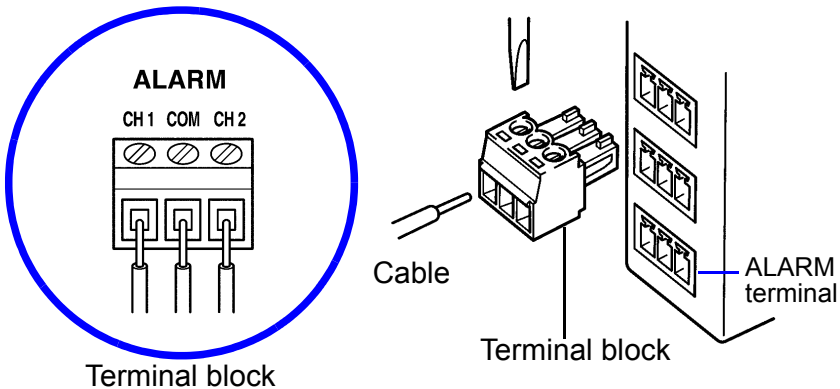

Connect the cable for CH1 output to CH1 and COM;
connect the cable for CH2 output to CH2 and COM.

Recommended Cable

Single-wire :0.14 to 1.5 mm²
 Stranded-wire :0.14 to 1.0 mm²
 AWG :26 to 16
 Cable strip length:5 mm (0.2")

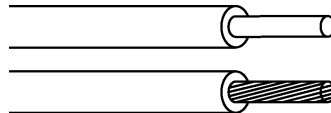

3.2.3 The Location of the Input/Output Cable

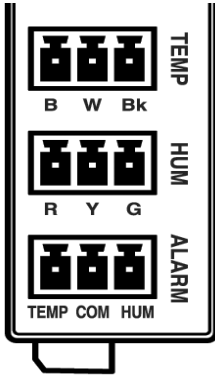

TEMP terminal (Input/output)	B	W	Bk
	Blue	White	Black
HUM terminal (Input/output)	R	Y	G
	Red	Yellow	Green
ALARM terminal (Input/output)	TEMP	COM	HUM
	Alarm output	Common	Alarm output

NOTE The TEMP and HUM terminals are used to connect the optional 9764 HUMIDITY SENSOR.

4.1 Alarm output



4.1.1 Output Rating



Ensure that the input does not exceed the maximum input voltage or current to avoid module damage, short-circuiting and electric shock resulting from heat building.

Output method	Open collector
Maximum input voltage / current	30 V, 20 mA max. (Allowable loss: 75 mW)
Signal logic	Enabled: ON Disabled: OFF

4.1.2 Internal Circuit

The alarm output circuit is configured as shown below.

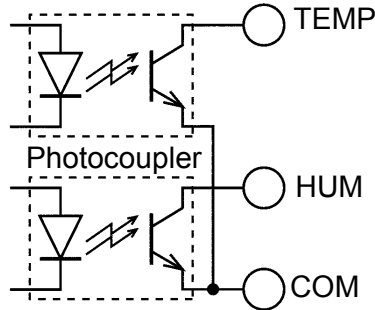

Internal circuit

NOTE

- Signal logic indicates the signal state in which a signal's function is enabled.
- The output transistor works as a switch between signal output and ground in the module. When output becomes enabled, the switch is turned on and current flows from the output signal to COM in the module. Therefore, a relay or LED lamp can be connected directly to the output terminal (page 28).

Circuit diagram

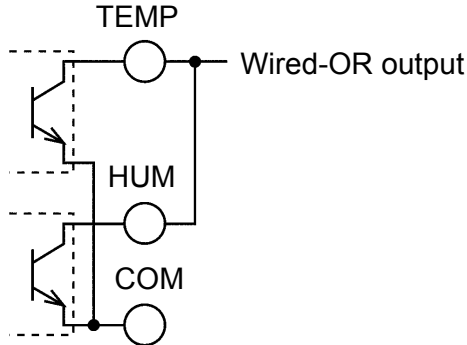
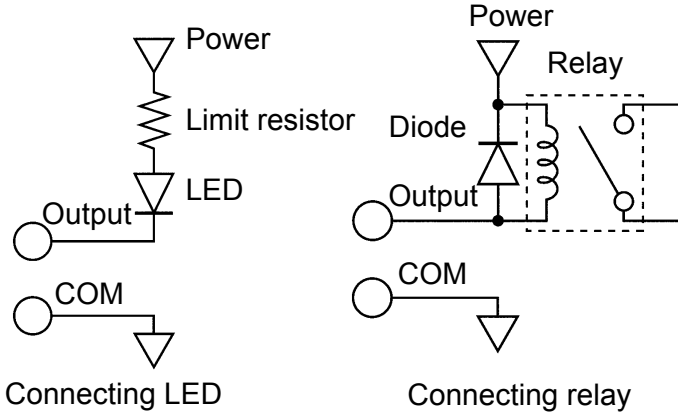

Using on Wired-OR Logic

NOTE

- When connecting a relay or LED lamp, ensure that the relay or lamp operates at up to 30 V and 20 mA (with allowable loss of 75 mW or less). When connecting a relay, be sure to use a diode to absorb counterelectromotive force.
- Open collector output operates on wired-OR logic by short-circuiting TEMP and HUM. Moreover, it enables the signal if an alarm occurs in either channel.

4.2 Insulation of Internal Circuit

In the 2301-20, the input circuit and alarm output are insulated from the CAN bus as shown in the block diagram below. (Withstand voltage: 1.4 kVAC, 50/60 Hz, Response current: 5 mA, 1 minute)

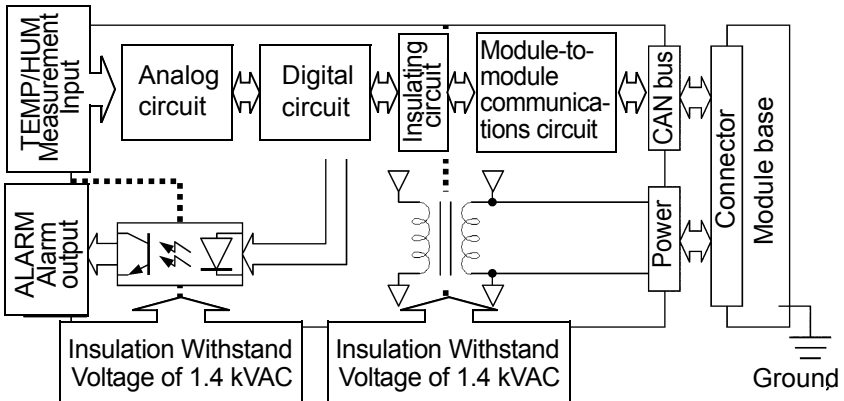
**NOTE**

The COM terminal of the alarm output terminal is used for both TEMP and HUM.

Specifications

Chapter 5

5.1 Basic Specifications

Sensor Type 9764 HUMIDIDTY SENSOR

Number of Inputs Temperature 1 CH + Humidity 1 CH

Measurement Range -40.0 to 85.0°C Resolution: 0.1°C
0.0 to 100.0%RH Resolution: 0.1%RH
(Display range: -10.0 to 110.0%RH)

Measurement Accuracy Temperature
-40.0 to -0.1°C $\pm 1.0^{\circ}\text{C}$
0.0 to 35.0°C $\pm 0.5^{\circ}\text{C}$
35.1 to 70.0°C $\pm 1.0^{\circ}\text{C}$
70.1 to 85.0°C $\pm 2.0^{\circ}\text{C}$
Humidity

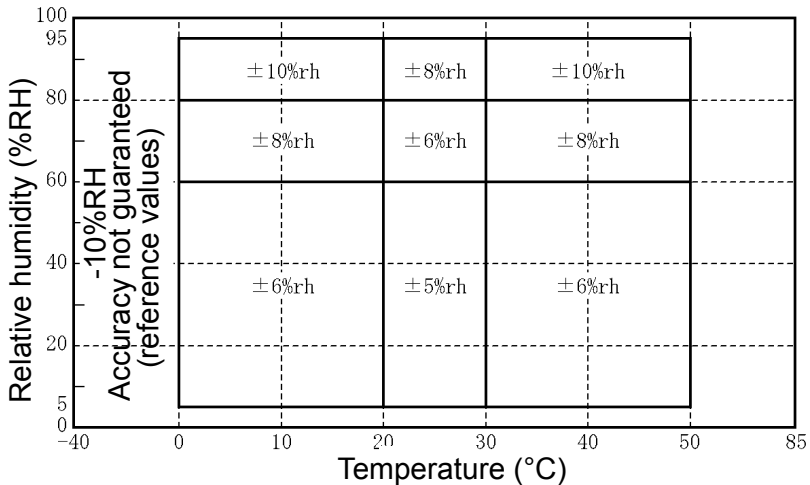

Period of Guaranteed Accuracy One year

Sampling 1 time / sec.

Input Terminal 3 Input terminal block \times 2

5.2 Function Specifications

Actual Time Management	Time management using PC application
Recording Start/End	Recording is started and ended by a command. (Immediate start, timed start, or timed end)
Recording Method	Interval recording (Measurements are recorded at a set recording interval.)
Recorded Data	One data set contains time, temperature, and humidity (for 1 channel each).
Recording Mode	<ul style="list-style-type: none"> • Instantaneous value • MAX/MIN/AVE • Instantaneous value + MAX/MIN/AVE Total 3 modes ◆Set the mode before the start of recording.
Recording End Condition	Memory full stop or indefinite ◆Set the condition before the start of recording.
Quantity of Recorded Data	512 k bytes Flash memory <ul style="list-style-type: none"> • Instantaneous value recording mode 30,000 data × 2 CH • MAX/MIN/AVE recording mode 15,000 data × 2 CH • Instantaneous value + MAX/MIN/AVE recording mode 12,000 data × 2 CH
Data Acquisition Method	All logging data, data before, at, and after the specified time, or the current instantaneous value (monitored value)
Recording Interval	1/2/5/10/15/20/30 sec. 1/2/5/10/15/20/30/60 min.
Alarm	Criterion threshold can be set to either Hi or Lo. The instantaneous value at every sampling is judged (effective in any measurement mode).

Alarm Output	Alarm output × 2 CH (Open collector: 30 VDC, 20 mA max., with allowable loss of 75 m Wmax.) ◆ Output is turned ON when an alarm (Hi or Lo) occurs. Whether to hold the alarm output can be selected. The reset switch or a command can be used to reset alarms.
Data Deletion	All items of data are deleted by a command. ◆ New data will be added to the previous data at the start of recording.
Power Outage Protection	After recovering from a power outage, the 2301-20 automatically returns to the state held before the outage.

5.3 General Specifications

Clock Accuracy	±100 ppm (Reference value at temperature from 0 to 50°C (32 to 122°F) without the communications module)
Backup	Recorded data (saved in flash memory) ◆ Data loss for up to 2 minutes before and after a power outage may occur.
Communication Interface	CAN bus
Maximum Rated Voltage to Earth	33 Vrms, 70 VDC
Rated Supply Voltage	5 V±0.3 VDC
Maximum Rated Power	1.4 W
Withstand Voltage	1.4 kVAC Between input and alarm output, Input/Output and CAN bus (50/60 Hz, Response current 5 mA, one minutes)
Dimensions	Approx. 22.5W × 96H × 85D mm (0.89"W × 3.78"H × 3.35"D) (excluding projections)
Mass	Approx. 120 g (4.2 oz.)

Accessories	Instruction manual.....	1
	Ferrite clamp	1
	Terminal block.....	3

Option	9764 HUMIDIDTY SENSOR
---------------	------------------------------

Operational Ranges for Temperature and Humidity	0 to 50°C (32 to 122°F), 80%RH or less (with no condensation)
---	---

Temperature and Humidity Ranges for Storage	-10 to 50°C (14 to 122°F), 80%RH or less (with no condensation)
---	---

Location for Use	Max. 2000 m (6562-ft.) height, indoors
------------------	--

Standards Applying	Safety	EN61010-1:2001 Pollution degree 2 Measurement Category I, (anticipated transient overvoltage 330 V),
	EMC	EN61326:1997+A1:1998+A2:2001 CLASS A

5.4 9764 HUMIDIDTY SENSOR Specifications

Operational Ranges for Temperature and Humidity	-40 to 85°C (-40 to 185°F), 0.0 to 100.0%RH (with no condensation)
---	--

Temperature and Humidity Ranges for Storage	-40 to 85°C (-40 to 185°F), 0.0 to 100.0%RH (with no condensation)
---	--

Response Time	Temperature : Approx. 100 sec. Humidity : Approx. 300 sec.
---------------	---

Temperature Sensor	Thermistor
--------------------	------------

Humidity Sensor	High polymer film (volume)
-----------------	----------------------------

Cord Length	Approx. 3 m
-------------	-------------

Dimensions	Sensor, Approx. 30W × 13H × 8D mm (1.18"W × 0.51"H × 0.31"D)
Long Time Stability	±1%RH (5 years at 25°C (77°F), 50%RH, reference value)

The 2301-20 may indicate a humidity measurement below zero or above 100%RH. These values indicate a change in low or high humidity levels, and do not indicate actual humidity (since values over 100% and lower than 0% are impossible).

Maintenance and Service

Chapter 6

6.1 Cleaning

To clean the instrument, wipe it gently with a soft cloth moistened with water or mild detergent. Never use solvents such as benzene, alcohol, acetone, ether, ketones, thinners or gasoline, as they can deform and discolor the case.

6.2 Service



Never modify the instrument. Only Hioki service engineers should disassemble or repair the instrument. Failure to observe these precautions may result in fire, electric shock, or injury.

- If the instrument seems to be malfunctioning, confirm that the cables are not open circuited before contacting your dealer or Hioki representative.
- When sending the instrument for repair, pack carefully to prevent damage in transit. Include cushioning material so the instrument cannot move within the package. Be sure to include details of the problem. Hioki cannot be responsible for damage that occurs during shipment.
- When transporting the 2301-20 or a system containing this module, tape the front of the module or take similar measures to avoid losing internal components.

HIOKI

DECLARATION OF CONFORMITY

Manufacturer's Name: HIOKI E.E. CORPORATION
Manufacturer's Address: 81 Koizumi, Ueda, Nagano 386-1192, Japan
Product Name: HUMIDITY MODULE
Model Number: 2301-20
Option: 9764 HUMIDITY SENSOR

The above mentioned products conform to the following product specifications:

Safety: EN61010-1:2001

EMC: EN61326:1997+A1:1998+A2:2001
Class A equipment
Equipment intended for use in industrial location

Supplementary Information:

The products herewith comply with the requirements of the Low Voltage Directive 73/23/EEC and the EMC Directive 89/336/EEC.

16 July 2004

HIOKI E.E. CORPORATION

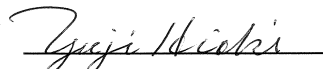

Yuji Hioki

President

2301A999-00



205 Westwood Ave
Long Branch, NJ 07740
1-877-742-TEST (8378)
Fax: (732) 222-7088
salesteam@Tequipment.NET