

# HIOKI

## 3127-10,3128-10

### CLAMP ON HIESTER

#### INSTRUCTION MANUAL

December 2004 Edition 1 Printed in Japan  
3127A981-00 04-12H

## HIOKI E. E. CORPORATION

### HEAD OFFICE

81 Koizumi, Ueda, Nagano 386-1192, Japan  
TEL +81-268-28-0562 / FAX +81-268-28-0568  
E-mail: os-com@hioki.co.jp URL http://www.hioki.co.jp/

### HIOKI USA CORPORATION

6 Corporate Drive, Cranbury, NJ 08512, USA  
TEL +1-609-409-9109 / FAX +1-609-409-9108

### Introduction

Thank you for purchasing the HIOKI "3127-10,3128-10 CLAMP ON HIESTER". To obtain maximum performance from the product, please read this manual first, and keep it handy for future reference.

## Inspection

When you receive the product, inspect it carefully to ensure that no damage occurred during shipping. If damage is evident, or if it fails to operate according to the specifications, contact your dealer or Hioki representative.

### Preliminary Checks

Before using the product the first time, verify that it operates normally to ensure that the no damage occurred during storage or transport. If you find any damage, contact your dealer or Hioki representative.

## Safety Information

### ⚠ DANGER

• Mishandling this product during use could result in injury or death, as well as damage to the product. Be certain that you understand the instructions and precautions in the manual before use. We disclaim any responsibility for accidents or injuries not resulting directly from product defects.

• To avoid short circuits and potentially life-threatening hazards, never attach the clamp to a circuit that operates at more than 750Vrms AC, or over bare conductors.

• In some cases, power lines may carry voltage spikes of several times the normal supply voltage. When measuring such power lines, there is a danger of electric accidents that may result in injury or death. For safety reasons, this tester should not be used to measure power lines carrying more than 250 V. When measuring such power lines, always use a tester with built-in overcurrent protection to guard against short circuits, such as models 3008 and a device showing the CAT III marking.

### NOTE

An industrial power line refers to a high-capacity supply circuit to equipment in factories or offices. A high-capacity supply circuit refers generally to a line carrying 20 A or more. This does not therefore include supply lines protected by overcurrent (fuse) or distribution breakers.

This manual contains information and warnings essential for safe operation of the instrument and for maintaining it in safe operating condition. Before using it, be sure to carefully read the following safety precautions.

### Safety Symbol

⚠ In the manual, the ⚠ symbol indicates particularly important information that the user should read before using the product.

The following symbols in this manual indicate the relative importance of cautions and warnings.

⚠ **DANGER** Indicates that incorrect operation presents an extreme hazard that could result in serious injury or death to the user.

⚠ **WARNING** Indicates that incorrect operation presents a significant hazard that could result in serious injury or death to the user.

⚠ **CAUTION** Indicates that incorrect operation presents a possibility of injury to the user or damage to the instrument.

NOTE Indicates advisory items related to performance or correct operation of the instrument.

## Specifications

Accuracy guaranteed for one year at 23±5°C(73±9°F), 80%RH or less

	3127-10	3128-10
AC A	6, 15, 60, 150, 300 A	15, 60, 150, 600, 1500 A 1000 A or more max. 2minutes
	The maximum permissible circuit voltage 750 Vrms AC (Insulated conductor) f.s. reading±3%	
AC V	150, 300, 750 V f.s. reading±3%	
DC V	75 V f.s. reading±3%	
Ω	0 to 1 kΩ Central scale 30 Ω, R100 Scale length±3%	
Temperature scale	-50°C to 200°C(standard, with optional probe) -50°F to 300°F(for USA only, with optional probe) Scale length±3%	
Protective system	Protection in Ω range up to 250 V AC commercial power input	
Core conductor diameter	33 mm 1.30"	55 mm, width 80mm 2.17", width 3.15"
Dimensions	Approx.78W×190H×34Dmm Approx.3.07"W×7.48"H ×1.34"D	Approx.99W×273H×34Dmm Approx.3.90"W×10.75"H ×1.34"D
Mass	Approx.340 g Approx.12.0 oz.	Approx.570 g Approx.20.1 oz.
The maximum permissible circuit voltage	AC750 V	
Drop proof	from one meter above concrete floor	
Operating temperature and humidity	0 to 40°C(32 to 104°F) 70%RH or less	
Storage temperature and humidity	-10 to 50°C(14 to 122°F) 70%RH or less	
Power source	Rated power voltage 1.5 VDC×1 R6P manganese battery×1	
Fuse	F0.5 A/250 V 30×6.4 dia. mm(non arcing type) Internal resistance 1.8	
Accessories	9067(Test lead) -----1 R6P manganese battery-----1 Spare fuse(F0.5 A/250 V)-----1 Strap band -----1 Instruction manual -----1	
Options	9351(Carrying case) --- 1 9148(Carrying case) ----1 CT-101A LINE SPLITTER 9021-01TEMPERATURE PROBE	

## Operating Precautions



Follow these precautions to ensure safe operation and to obtain the full benefits of the various functions.

### ⚠ DANGER

• This product should only be connected to the secondary side of a breaker, so the breaker can prevent an accident if a short circuit occurs. Connections should never be made to the primary side of a breaker, because unrestricted current flow could cause a serious accident if a short circuit occurs.

• To avoid electric shock, short circuits and damage to the instrument, observe the following precautions:  
Check the position of the range switch before taking measurements.  
Disconnect the test leads from the measurement object before switching ranges.

### ⚠ WARNING

• Do not allow the instrument to get wet, and do not take measurements with wet hands. This may cause an electric shock.  
• To avoid electric shock when measuring live lines, wear appropriate protective gear, such as insulated rubber gloves, boots and a safety helmet.  
• To avoid electrical shock accidents while measuring voltage, make sure that the metal parts of the clamp-on sensor do not contact the skin or other metallic objects.  
• To avoid electrical accidents while measuring current, do not connect the test leads to the instrument.  
• Before using the instrument, make sure that the insulation on the test leads is undamaged and that no bare conductors are improperly exposed. Using the instrument in such conditions could cause an electric shock, so contact your dealer or Hioki representative for replacements (Model 9067).

### ⚠ CAUTION

• Note that the instrument may be damaged if voltage or current the measurement range.  
• Do not store or use the instrument where it could be exposed to direct sunlight, high temperature or humidity, or condensation. Under such conditions, the instrument may be damaged and insulation may deteriorate so that it no longer meets specifications.

### NOTE

• Correct measurement may be impossible in the presence of strong magnetic fields, such as near transformers and high-current conductors, or in the presence of strong electromagnetic fields such as near radio transmitters.  
• To avoid corrosion from battery leakage, remove the batteries from the instrument if it is to be stored for a long time.  
• If the tester shows incorrect operation during use, discontinue use at once and contact your dealer or hioki representative.

## Parts Names

3127-10

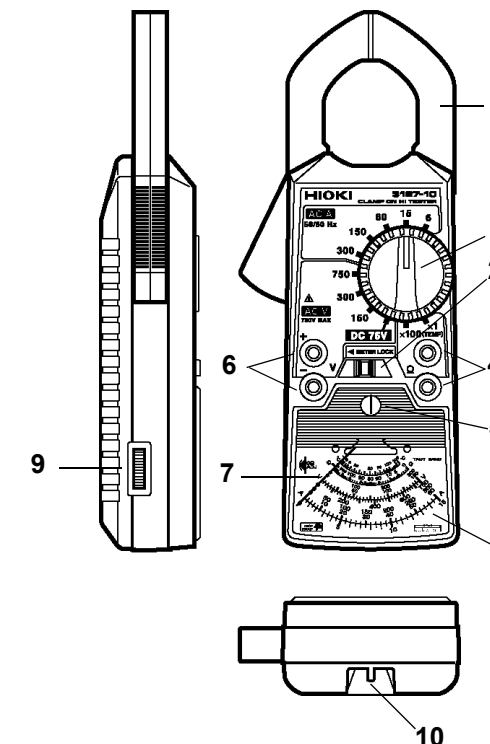

1 Jaws 2 Meter lock switch  
3 Range selector switch 4 Ohms( ) terminal  
5 Zero adjust screw 6 Voltage terminal  
7 Pointer 8 Meter scale 9 0 ADJ knob  
10 Carrying strap

3128-10

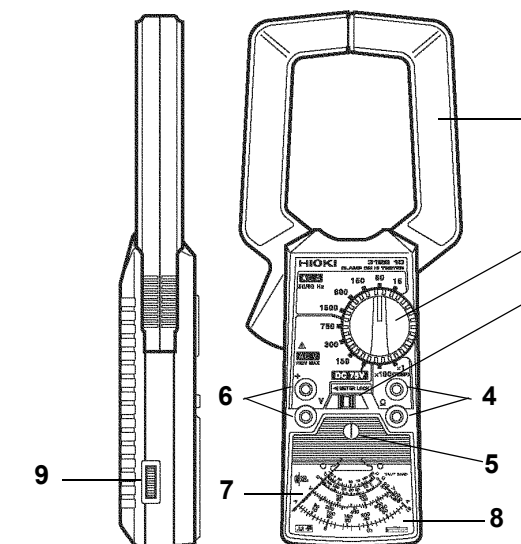

# Measurement Procedure

## Measurement Preparations

- Unlock the meter (switch the lock knob to the open position, the right).
- Check that the needle is aligned with 0, and adjust it with the zero adjust if it is not.
- Always check the fuses and zero adjust the meter before use.  
Set the meter to the range, short out the lead pins, and verify that the meter wobbles. In the event of a meter problem, check the fuse first.

## AC current Measurement (AC A)

### ! WARNING

- To avoid electrical accidents while measuring current, do not connect the test leads to the instrument.
- Current measurements exceeding 1000 A should be of short duration. Heat builds up in the clamp core proportionate to the current value, and will reach a dangerous level over a long period of time.(3128-10)

### NOTE

Attach the clamp around only one conductor. Single-phase (2-wire) or three-phase (3-wire) cables clamped together will not produce any reading.

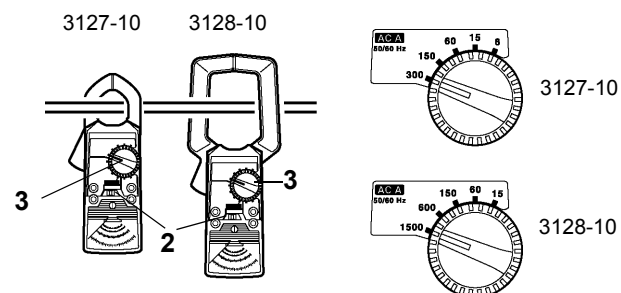

- Set the range selector 3 to the highest current range.
- Clamp one conductor inside the core.
- If the reading is low, lower the range one step at a time and check the reading.
- If measurement is performed where the meter is difficult to read, slide the meter lock to the left.

## Voltage Measurement (AC V / DC V)

### ! DANGER

- The maximum input voltage is 750V AC, 75V DC. Attempting to measure voltage in excess of the maximum input could destroy the instrument and result in personal injury or death.
- To avoid electric shock, short circuits and damage to the instrument, observe the following precautions:  
Check the position of the range switch before taking measurements.  
Disconnect the test leads from the measurement object before switching ranges.

### ! WARNING

To avoid possible electrical shock or damage to the clamp sensor, avoid touching the exposed metallic parts of the clamp sensor with your hands or any other metallic objects while measuring voltage.

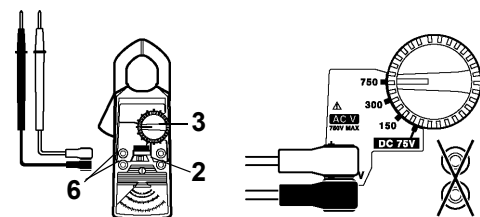

- Switch the range selector 3 to the highest range of AC V or DC V.
- Insert the test lead into the V terminal 6.
- Contact the tip of the test lead in parallel with the measurement unit.
- If the reading is low, lower the range one step at a time and check the reading.

## Resistance Measurement ( $\Omega$ )

### ! WARNING

Turn off the power and discharge the capacitors before measuring resistance in a circuit.

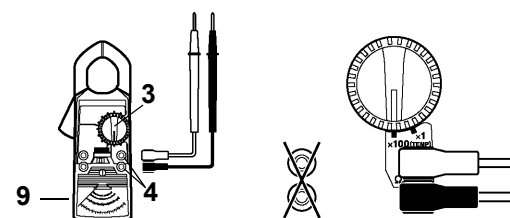

- Set the range selector 3 to  $\Omega$ .
- Connect the test lead to the  $\Omega$  terminal 4.
- Short out the tips of the test leads and adjust the 0  $\Omega$  ADJ knob 9 so that the needle reads zero. If it will not adjust to 0, the battery should be replaced.
- Contact the test leads to the test location and read the resistance directly.

## Temperature Measurement

When the optional 9021-01 temperature probe is used, the TEMP scale can be used for direct reading of temperature. The range used is "x100".

## Replacing the Battery 11 and Fuse 12

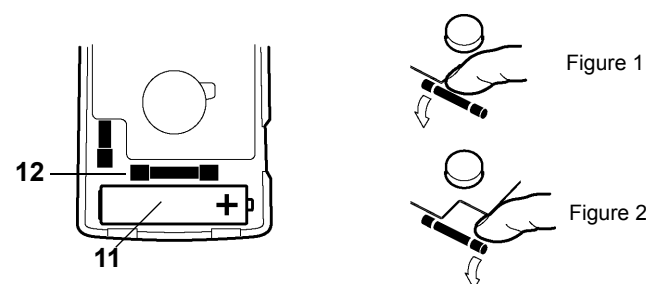

### ! WARNING

- To avoid electric shock when replacing the batteries and fuse, first disconnect the test leads from the object to be measured.
- After replacing the batteries or fuse, replace the cover and screws before using the instrument.

## Replacing the Battery

### ! WARNING

- Be sure to insert them with the correct polarity. Otherwise, poor performance or damage from battery leakage could result.
- To avoid the possibility of explosion, do not short circuit, disassemble or incinerate batteries.
- Handle and dispose of batteries in accordance with local regulations.

- Remove the back casing screw and take off the back casing.
- Replace the battery with new one.
- After replacing the battery, always replace the back casing and tighten the screw before using the unit.

## Replacing the Fuse

### ! WARNING

Replace the fuse only with one of the specified characteristics and voltage and current ratings. Using a non-specified fuse or shorting the fuse holder may cause a life-threatening hazard. Fuse type: F0.5 A/250 V (non-arcing) 6.4A~30 mm dia.

- Remove the back casing screw and take off the back casing.
- Replace the fuse with new one.

### NOTE

- Use the fuse is the one stored inside the main unit.
  - Be sure to replace the spare fuse with a new one if it is used to replace a blown fuse.
  - For removal refer to figure 1, and for insertion to figure 2.
- After replacing the fuse, always replace the back casing and tighten the screw before using the unit.

## Measurement of current and voltage in equipment with double-core cords

When current and voltage are measured in equipment with double-core cords, the optional CT-101A line splitter makes measurement easy.

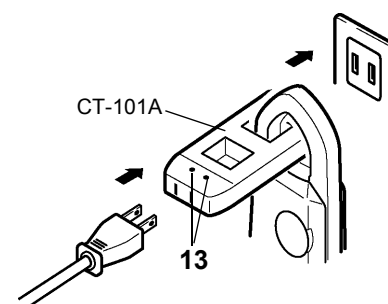

### ! WARNING

The maximum input voltage and current of the CT-101A is 100 VAC, 15 Arms. Ensure that the input does not exceed the maximum input voltage or current to avoid instrument damage, short-circuiting and electric shock resulting from heat building.

## measurement method

- Plug the power cord of the electrical equipment to be measured into the line splitter, and the line splitter plug into the power outlet.
- Current can be measured by running the clamp tester core through the line splitter window. x1 and x10 readings are provided.
- Voltage can be measured by inserting the test pin into the voltage measurement terminal 13.

# Maintenance

To clean the instrument, wipe it gently with a soft cloth moistened with water or mild detergent. Never use solvents such as benzene, alcohol, acetone, ether, ketones, thinners or gasoline, as they can deform and discolor the case.

# Service

- If the instrument seems to be malfunctioning, confirm that the batteries are not discharged, and that the test leads and fuse are not open circuited before contacting your dealer or Hioki representative.
- Pack the instrument so that it will not sustain damage during shipping, and include a description of existing damage. We cannot accept responsibility for damage incurred during shipping.