

HIOKI

INSTRUCTION MANUAL

3196

POWER QUALITY ANALYZER



HIOKI E. E. CORPORATION

Contents

Introduction.....	1
Symbols.....	1
Outlook of Operating Procedures.....	2
Chapter 1	
Overview	3
1.1 Product Overview	3
1.2 Features	4
Chapter 2	
Key Explanations and Screen Configuration	9
2.1 Key Explanations	9
2.2 Screen Names and Configurations	11
2.2.1 Common Display Areas	12
2.2.2 Screen Configurations	16
2.2.3 Screen Details	20
Chapter 3	
Connections	37
3.1 Connection Diagram	39
Chapter 4	
Making System Settings (SYSTEM Screen)	43
4.1 Using the SYSTEM Screen	43
4.2 Checking the Connection	45
4.2.1 Confirming the Connection Diagram	45
4.2.2 Checking the Connection	47
4.3 Making System Settings	49
4.3.1 Main Settings	49
4.3.2 Recording Settings	59
4.3.3 Hardware Settings	59
4.4 Event Settings Screen	63
4.4.1 Measurement Settings	63
4.5 Load/Save Screen	64

Chapter 5

Using Waveforms, Vectors, DMMs, and Bar Graphs (VIEW Screen) _____ 65

5.1	Using the VIEW Screen	65
5.2	Waveform Display	67
5.3	Vector Display	70
5.4	DMM Display	73
5.5	Harmonics Display	74
5.5.1	Harmonics Bar Graph	74
5.5.2	Harmonics List Screen	76

Chapter 6

Using the Time Series Graph (TIME PLOT Screen) 79

6.1	Using the TIME PLOT Screen	79
6.2	Time Plot Settings	81
6.3	Changes in RMS Value	89
6.4	Changes in Voltage	93
6.4.1	Graphing Voltage Fluctuations for Each Interval	93
6.4.2	Graphing Voltage Fluctuations for Events	96
6.5	Changes in Harmonics	100
6.6	Flicker	104
6.6.1	IEC Flicker Meter and ΔV_{10} Flicker Meter	104
6.6.2	IEC Flicker Graph	107
6.6.3	IEC Flicker List	110
6.6.4	ΔV_{10} Flicker Graph	111
6.6.5	ΔV_{10} Flicker List	114

Chapter 7

Using Events (EVENT Screen) _____ 115

7.1	Using the EVENT Screen	116
7.2	Event Detection Method	118
7.3	Event Settings	121
7.3.1	Voltage/Power Event Settings	122
7.3.2	Harmonics Event Setting	126
7.4	Event List Display	127
7.5	Analyzing Event Occurrences	130
7.6	Analyzing Transient Waveforms	131
7.7	Event Monitor Display	134







Chapter 8	
Using the External Control Terminals	135
8.1	Connecting to the External Control Terminal 136
8.2	Event Input Terminal (EVENT IN) 137
8.3	Event Output Terminal (EVENT OUT) 138
Chapter 9	
Loading and Saving Settings and Measured Data	141
9.1	Using the Internal Memory 142
9.2	Using a PC Card 143
9.2.1	Selecting a PC Card 143
9.2.2	Inserting and Removing the PC Card 144
9.2.3	File Types 145
9.2.4	Saving and Loading Files 147
Chapter 10	
Using a Printer	157
10.1	Setting the Printer 157
10.2	Printing Hard Copies 158
Chapter 11	
Using the PC	159
11.1	Remote Control and Monitoring Using an RS-232C Interface 160
11.1.1	Connecting a Modem 161
11.1.2	Setting the 3196 162
11.1.3	Setting the PC 163
11.2	Control and Monitoring Using a LAN Interface 167
11.2.1	Connecting the 3196 168
11.2.2	Setting the 3196 168
11.2.3	Setting the PC 172
11.3	HTTP Server Function 174
11.3.1	Overview 174
11.3.2	Setting the HTTP Server Function 175
Chapter 12	
Specifications	179
12.1	Product Specifications 179
12.2	Measurement Specifications 183
12.3	Setting Functions 194
12.4	Formulae 199

Appendix	213
Measurement Range and Nominal Voltage.....	213
TIME PLOT Recording Method	215
Event Waveform Recording Method.....	216
Detecting Anomalies and Phenomena Due to Drops in Power Quality	217
Terminology.....	218
ΔV_{10} Flicker Text Time-sequence Data-header Composition	226
IEC Flicker Text Time-sequence Data-header Composition .	226
Text Event Waveform Data Format Composition	226
Text Voltage Fluctuation Event Data Format Composition....	226
Text Event Data-format Composition	227
Contents of Automatic Setting of Events (thresholds)	228
Event Recording Sequence (Priority Order)	230
Block Diagram (Analog).....	231
Block Diagram (Digital).....	232

Introduction

- The 3196 Quick Start Manual accompanies this device. Refer to this guide for precautions, information about connecting peripheral devices, connection methods, and measurement methods.
- The present Instruction Manual mainly deals with how to make screen settings and how to set peripheral devices.
- A clamp-on sensor (optional) is required to measure electrical currents with this device. For more details, refer to the Instruction Manual of the clamp-on sensor that you are using.
- For detailed information on the EN50160, see the Instruction Manual for EN50160.

Symbols

	Indicates that incorrect operation presents a possibility of injury to the user or damage to the product.
	Indicates advice about product performance and operations.
	Indicates references.
	Indicates quick references for operations and troubleshooting remedies.
	Indicates that the explanation of a technical term is at the bottom of the page.
	Indicates the explanation of a technical term.

Outlook of Operating Procedures

Indicates the purpose of the settings.

Indicates the screen name selected with the DF key.

Indicates the name of an item displayed on the screen.

Connection method settings (CH 1, 2, 3)

Navigation: SYSTEM, DF 2, MEASURE, Wiring, ENTER (Select from pull-down menu), ENTER (Confirm), ESC (Cancel)

U.Reference	120 V
Frequency	50 Hz
PLC Source	UI
U. Calc. Type	PHASE-N

1P2W To measure single-phase two-wire power lines
1P3W To measure single-phase three-wire power lines
3P3W2M To measure single-phase three-wire power lines (using the 2 power meter method)
 (Use this when measuring three-phase power with 2-spot current measurement only.)
3P3W3M To measure three-phase three-wire power lines (using the 3 power meter method)
3P4W To measure three-phase four-wire power lines

Indicates operation keys.

Displays the item selected in the drop-down list box accompanied by an explanation.

Overview

Chapter 1

1.1 Product Overview

The 3196 POWER QUALITY ANALYZER detects power line anomalies and analyzes power line quality.

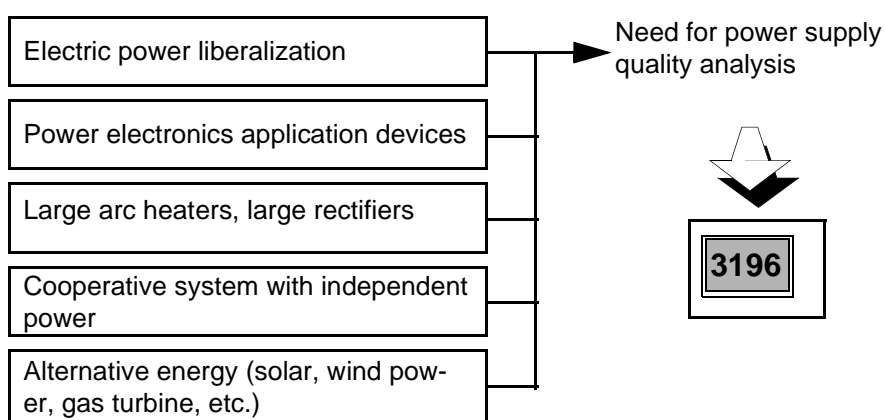

◆ Correctly analyze abnormal phenomena

Analysis can be performed by correlating measurement items with particular standard characteristics to ascertain the causes of power line anomalies.

◆ Continuous long-term monitoring and recording

Power line anomalies often occur intermittently, so they must be captured when an anomaly occurs, along with its type and intensity.

◆ Remote control

The type and time of occurrence of anomalies can be instantly determined through a variety of interfaces (RS-232C, LAN, printer and modem).

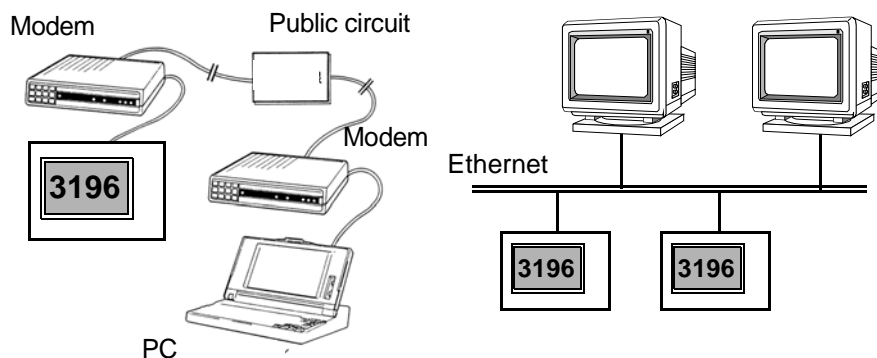

1.2 Features

- ◆ **Safe design**

Designed to comply with safety standard EN61010-1:2001.
- ◆ **Supports a variety of power lines**

Measures single-phase 2-wire, single-phase 3-wire, three-phase 3-wire and three-phase 4-wire systems.
An extra input channel is provided for uses such as measuring power lines of a second system, for direct voltage measurement or for measuring a neutral line.
- ◆ **Simultaneous measurement of multiple elements of power supply quality**

Multiple power supply quality parameters can be selected as desired for simultaneous measurement.

 1. High speed voltage quality parameter
Transient overvoltage (impulse)
 2. RMS voltage quality parameters
Voltage swell (surge), voltage dip (sag), voltage interruption
 3. Power quality parameters
Frequency, voltage, current, active power, apparent power, reactive power, power factor (displacement power factor)
 4. 3-Phase quality parameters
Voltage unbalance factor, current unbalance factor
 5. Harmonic quality parameters
Harmonic voltage, current and power; inter-harmonic voltage and current; harmonic voltage and current phase angle; total harmonic voltage and current distortion factors (THD-F, THD-R); total inter-harmonic voltage and current distortion factors (THD-F, THD-R)
 6. Other parameters
K factor, flicker
- ◆ **High-speed impulse detection and waveform display function**

Four voltage channels are sampled at 2 MS/s, so high-speed detection and waveform display can be performed at up to 0.5 μ s and high voltage (2000 Vpk transient overvoltage (impulse)).

- ◆ **Δ V10 Flicker, IEC flicker measurement**
Select either IEC flicker (Pst, Plt) regulated by international standards, or Δ V10 Flicker commonly used in Japan, and measure with power quality parameters.
- ◆ **Δ -Y and Y- Δ conversion functions provided**
 Δ -Y conversion can be performed on three-phase 3-wire systems, and Y- Δ conversion can be performed on three-phase 4-wire systems. In either case, line-to-line voltage or phase-to-neutral voltage display is available.
- ◆ **Up to one month continuous measurement**
Data is saved to internal memory during the measurement period. Use of a PC card enables continuous measurement for one month at maximum.
- ◆ **Time plot graph display**
Fluctuations in various power quality parameters are displayed in time plot graphs. Calculated maximum, average and minimum values for each interval are displayed.
- ◆ **Event detection functions**
 1. Event detection using preset threshold settings
Events exceeding thresholds are detected by setting thresholds for various power quality parameters.
Up to 100 events can be saved to internal memory.
Up to 1000 events can be saved on PC card.
Events that occur simultaneously are correlated and treated as a single event.
 2. Event Analysis
Confirm when and what kind of events have occurred from the Event List.
Each event can be analyzed using waveforms, vectors, harmonic bargraph and related parameter values.
 3. External input and output of events
A signal can be output when an event occurs. Also, an externally applied signal can be set to be recognized as an event.
- ◆ **Easy-to-see TFT color LCD**
The display is a 6.4-inch (640 x 480 dot) high-contrast, wide-viewing-angle TFT color liquid crystal display. The screen is easy to see in both bright and dark environments, and is capable of showing many power quality parameters at the same time.

- ◆ **RS-232C and LAN interfaces provided**
Connect a PC, printer or modem for remote control and data output.
- ◆ **PC Card interface provided**
Measurement and event data can be preserved by saving to a PC Card.
Setting conditions and measurement data can be stored and read back using a PC Card.
- ◆ **Seven selectable display languages**
Select the display language from Japanese, English, German, French, Spanish, Italian, or Chinese (Simplified).
- ◆ **Nickel-Metal-Hydride battery pack supplied**
The Ni-MH battery backs up internal data when power is off.
When fully charged, data is backed up for 30 minutes when power is turned off.
- ◆ **Compact and light weight**
The compact size and light weight allows installation even in limited space, such as in a cubicle.
- ◆ **Carrying case options for portability**
The optional cases allow measurements to be taken without removing the instrument. Choose from a light-weight soft case or water-resistant hard case.
- ◆ **A choice of optional clamp-on sensors**
Select either the 9660 CLAMP ON SENSOR (100 A rms rating), the 9661 CLAMP ON SENSOR (500 A rms rating), the 9667 FLEXIBLE CLAMP ON SENSOR (500/ 5000 A rms rating), or the 9669 CLAMP ON SENSOR (1000 A rms rating), 9694 CLAMP ON SENSOR (5 A rms rating).
The 9657-10 CLAMP ON LEAK SENSOR and 9675 CLAMP ON LEAK SENSOR also can be used.
- ◆ **Control instrument settings and data acquisition by Web browser**
HTTP server functions are built in
Instrument settings and data acquisition can be controlled by common Internet Web browsers like Internet Explorer or Netscape Navigator.

◆ **Control instrument settings and data acquisition by Web browser**

HTTP server functions are built in. Instrument settings and data acquisition can be controlled by common Internet Web browsers like Internet Explorer or Netscape Navigator.

◆ **PC application software (option) for analyzing a large volume of data**

By using the optional 9624 PQA-HiVIEW or 9624-10 PQA-HiVIEW PRO, a large volume of long-term measurement data recorded on a PC card can be analyzed.

◆ **Remotely downloaded application software provided**

By using the Down96 download application supplied with the product, data in the main unit can be downloaded from a distant location via LAN or RS-232C (modem).

◆ **EN50160-compliant evaluations**

Conforms to the European standard EN50160 (Voltage characteristics of electricity supplied by public distribution systems) and suitable for evaluation of the voltage quality of a power system.

◆ **Optional GPS BOX available for precisely timed measurements**

Using the XD112 GPS BOX, measurements can be precisely timed using communications satellites.

◆ **Measurement is possible on 400 Hz power lines**

Measure 400 Hz power such as that used for aircraft equipment and shipping tests.

Because the usual shipping tests do not include 400 Hz measurements, please advise when ordering if your application requires guaranteed accuracy at 400 Hz.

For detailed information on the EN50160, see the Instruction Manual for EN50160.



Key Explanations and Screen Configuration

Chapter 2

2.1 Key Explanations

Front Panel

Display

6.4-inch, TFT color LCD display

DF1 to DF4 keys

Press these Display Function DF keys to select the type of display.

- ❖ "Front Panel Enhanced View"(page 10)

SYSTEM/ VIEW/ TIMEPLOT/ EVENT key

Select the screen type according to the intended usage

- ❖ "Front Panel Enhanced View"(page 10)

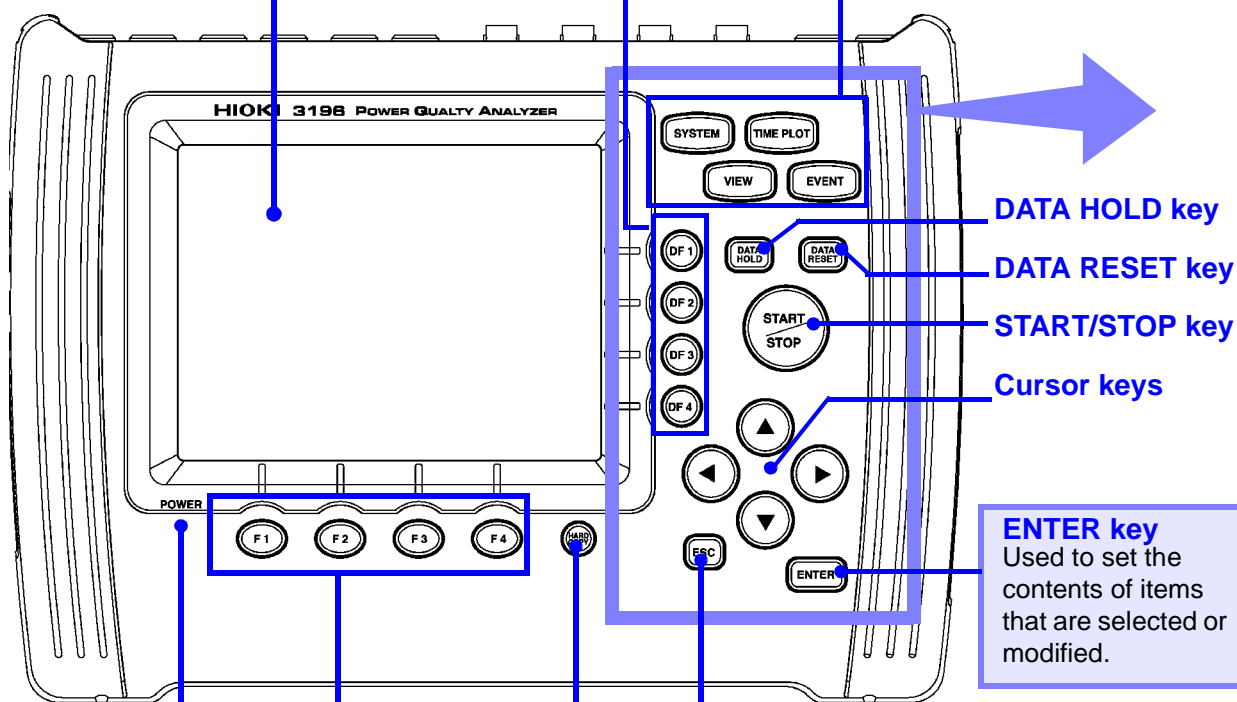

DATA HOLD key

DATA RESET key

START/STOP key

Cursor keys

ENTER key

Used to set the contents of items that are selected or modified.

F1 to F4 keys

Select or change display or setting items.

ESC key

Ignores selected or changed items and returns the original setting.

POWER LED

This lamp lights when the power is on.

Powered by AC adapter: Lit green
Powered by battery pack: Lit red

HARD COPY key

Prints a screen image, or outputs the screen image as a file to a PC Card.

Front Panel Enhanced View

SYSTEM key

Displays the **[SYSTEM]** screen (for selecting display of system settings).

VIEW key

Displays the **[VIEW]** screen (for selecting an Analysis view)

TIME PLOT key

Displays the **[TIME PLOT]** screen (for selecting the time plot graph).

EVENT key

Displays the **[EVENT]** screen (for selecting events).

DATA HOLD key

Temporarily stops display of measured values. Press again to cancel. While recording, display of the measured value can be stopped for confirmation.

DATA RESET key

All measurement data is erased from internal memory. Press this key to reset before restarting recording.

START/STOP key

Starts and stops recording. To start recording, press the DATA RESET key to reset the data, then press this key.

Cursor keys

These keys move the cursor on the screen. Use to scroll the TIME PLOT screen.

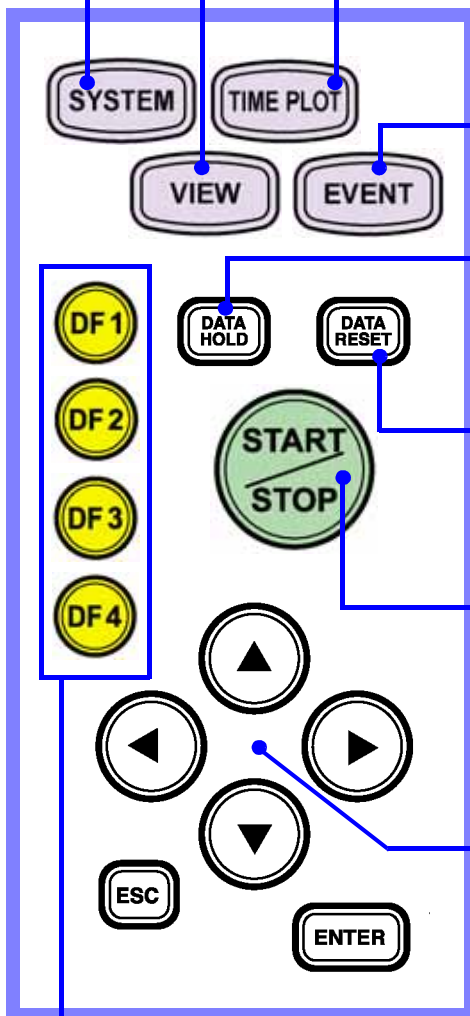

DF1 to DF4 keys (Display function)

Select a screen to display from the selected screen type: SYSTEM, VIEW, TIME PLOT or EVENT. The screen selections are as follows:

[SYSTEM] screen..... Wiring diagram, Main settings, Event settings, Load/Save, etc.

[TIME PLOT] screen..... RMS fluctuations, Voltage fluctuations, Harmonic fluctuations, Flicker display, etc.

[VIEW] screen..... Waveforms, Vectors, DMM, Harmonic display, etc.

[EVENT] screen..... List, Monitor, etc.

2.2 Screen Names and Configurations

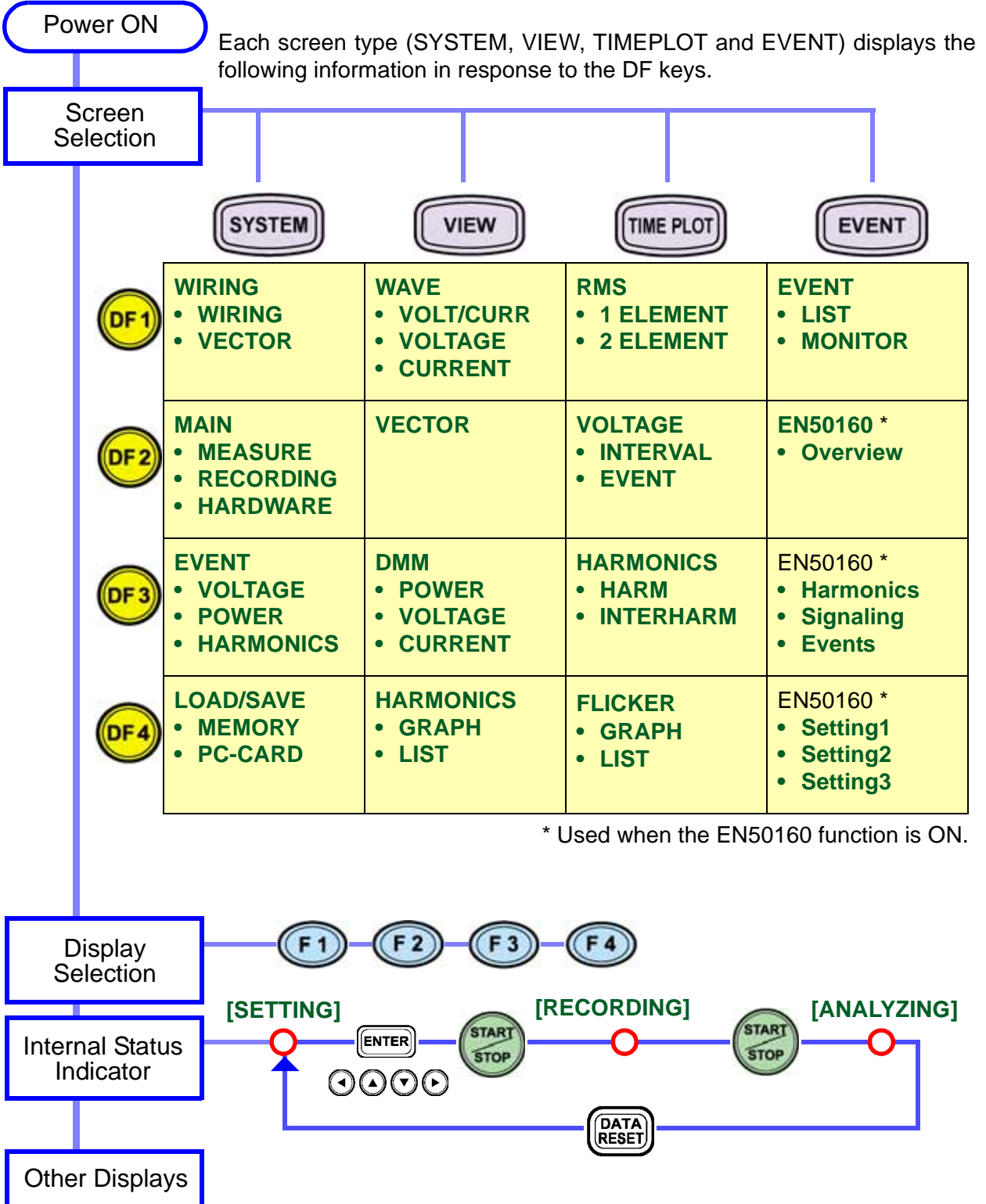

2.2.1 Common Display Areas

The display elements common to all screens on the 3196 are as follows.

Top of Screen

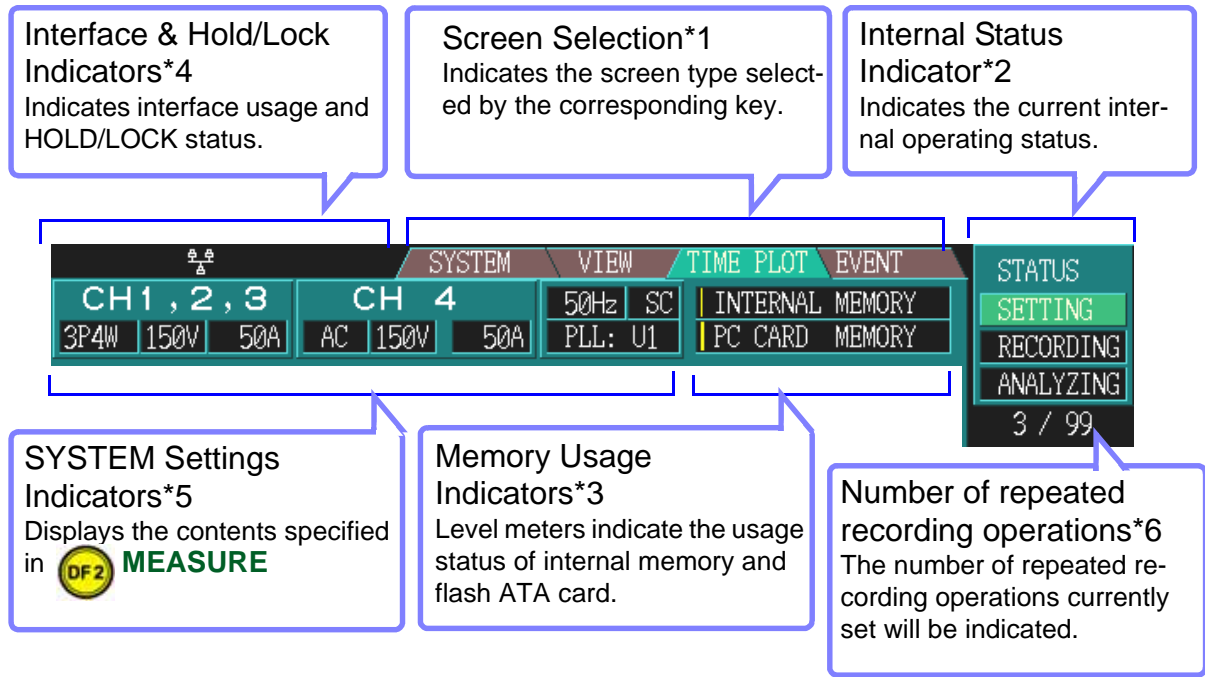

Bottom of Screen

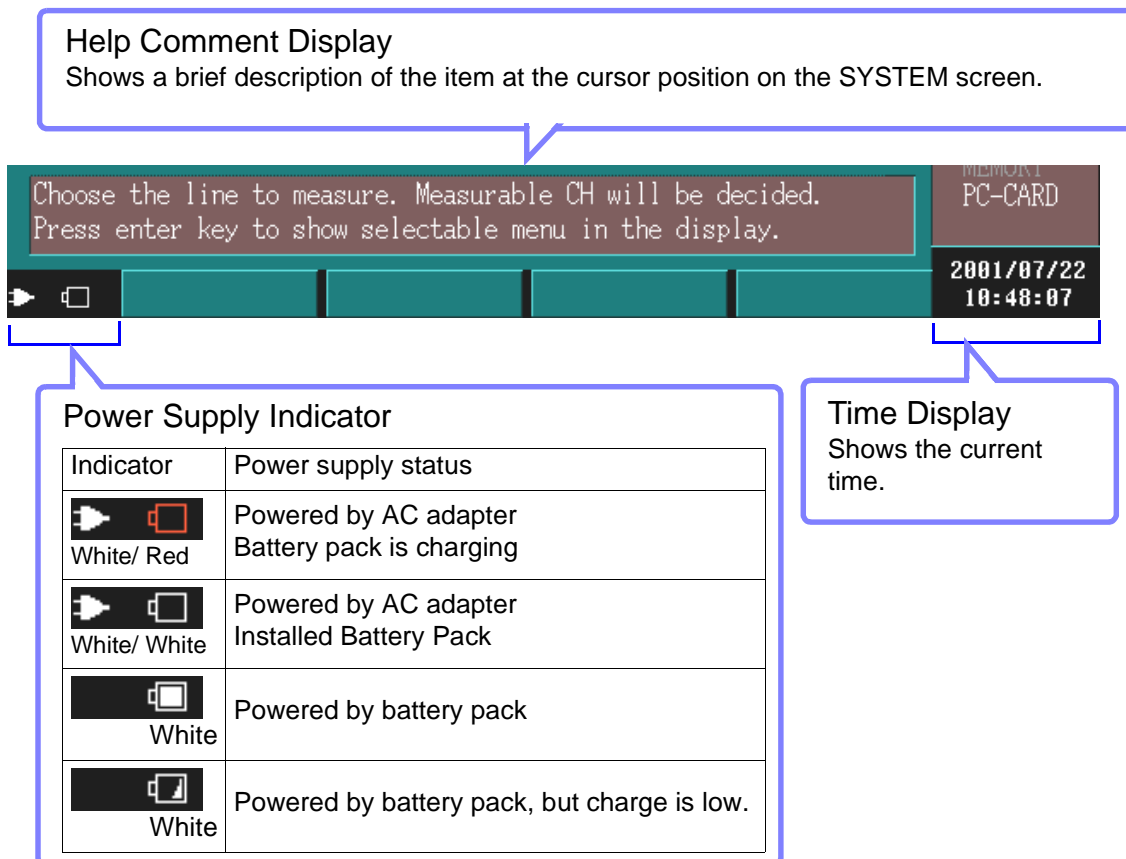

***1:Screen Selection Display**

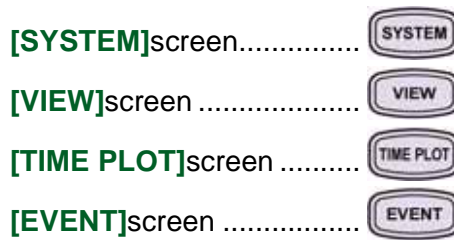
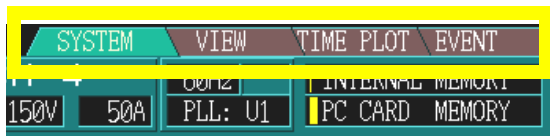

***2:Internal Operating Status Display**



One of [SETTING], [RECORDING], [WAITING] (until preset time to start measuring), or [ANALYZING] is displayed to indicate the internal status of the instrument. The internal status is changed by pressing **START/STOP** to start/stop recording.

Display	Internal status description	Real-time measurement	Recording status
[SETTING]	When turned on, there is no recorded data in the instrument	Possible	Preparation for recording (not recording)
[WAITING]	Waiting until a preset start time to begin measuring	Possible	
[RECORDING]	Recording has started and measurement data is being saved to the instrument's internal memory (and perhaps to a PC Card)	Possible	Recording in progress
[ANALYZING]	Recording has finished and the instrument is ready for analysis of the measurement data in internal memory	Possible	Recording finished

Normal Measurement

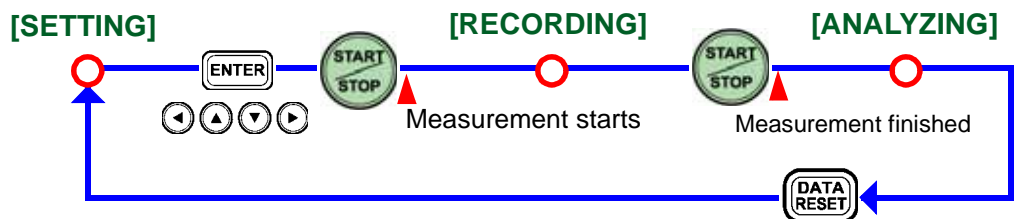

Measurement with Specified Time Settings

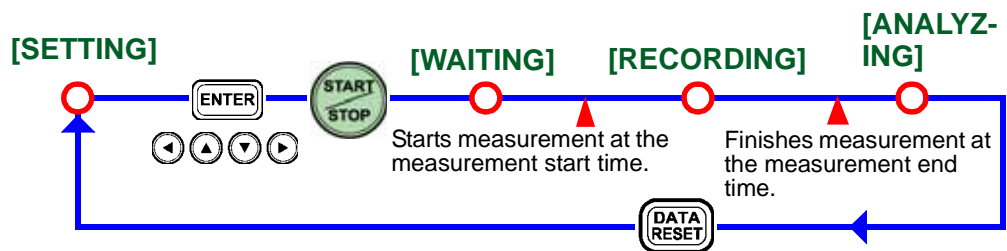

If the preset measurement start time has already passed, measurement starts immediately.

***3:Memory Usage Indicators**



INTERNAL MEMORY: Internal memory
PC CARD MEMORY: ATA flash card

TIME PLOT related data capacity
 Measurement stops when memory becomes full.
 (Selectable Stop/Continuous) Total capacity: 5 MB



Up to 100 EVENT data sets can be stored
 After 100 events are stored, the earliest are overwritten.
 Total capacity: 8 MB

***4:Status Icons**

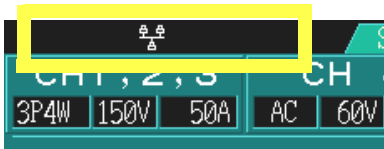

Interface usage status indicators	
	Indicates the printer is ready for use.
	Indicates the modem is ready for use.
	Indicates the LAN interface is ready for use.
HOLD/LOCK status indicators	
	Indicates the DATA HOLD key has been pressed to activate the Data Hold function.
	Indicates the KEY LOCK switch has set to lock the keys.
PC card status display	
	Lights when the PC Card is being accessed.

***5: SYSTEM settings display**

Voltage/Current Range

Red Indication: means out of range
 In this case, increase the range setting.

Frequency of Measured Line

Red Indication: means the measurement frequency is different from the line frequency

PT(VT)/CT Ratio

[SC] (scaling): Appears when the PT or CT ratio has been set.
 [(Not displayed)]: when the PT and CT ratios are both 1.

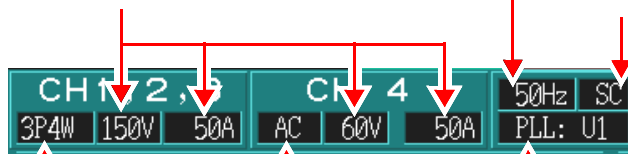

Measurement Line type
 Set on the SYSTEM screen

CH4 Voltage measurement function
 (AC/ DC/OFF)

PLL Sync Frequency source
 Indicates red when no input is applied at the selected source.

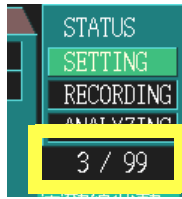
***6: Number of repeated recording operations**

When the repeated recording function is set, the number of repeated recording operations currently set will be indicated.

Repeated recording operations can be conducted up to 99 days at one-day measuring intervals, and up to 99 weeks at one-week measuring intervals.

The measured data file of repeated recording is saved as a separate binary file for each one-day or one-week period on the PC card.

2.2.2 Screen Configurations

For a detailed description of each screen, see 2.2.3 "Screen Details", and for information about how to make settings, see the references on the right.

SYSTEM Screen

DF1	WIRING		❖ 4.2 "Checking the Connection"(page 45)
	WIRING	Displays connection diagrams. You can confirm the connections of the voltage cord and clamp sensors.	❖ 4.2.1 "Confirming the Connection Diagram"(page 45)
	VECTOR	Displays voltage and current vector diagrams. You can check the oscillation and phase.	❖ 4.2.2 "Checking the Connection"(page 47)
DF2	MAIN		❖ 4.3 "Making System Settings"(page 49)
	MEASURE	Set the connection, voltage and current ranges, PT and CT ratios, and clamp sensors.	❖ 4.3.1 "Main Settings"(page 49)
	RECORDING	Make time settings, such as the measurement start and end times, and intervals.	❖ 6.2 "Time Plot Settings"(page 81)
	HARDWARE	Make hardware settings, such as the display language, beep, screen color, clock, as well as make RS-232C and LAN settings.	❖ 4.3.3 "Hardware Settings"(page 59)
DF3	EVENT		❖ 7.3 "Event Settings"(page 121)
	VOLTAGE	Set the threshold for events, such as transient, swell, dip, and interruption.	❖ 7.3.1 "Voltage/Power Event Settings"(page 122)
	POWER	Set the threshold for events, such as voltage, current, distortion factor for power and unbalance factor.	❖ 7.3.1 "Voltage/Power Event Settings"(page 122)
	HARMONICS	Set the threshold for harmonics events.	❖ 7.3.2 "Harmonics Event Setting"(page 126)
DF4	LOAD/SAVE		❖ Chapter 9 "Loading and Saving Settings and Measured Data"(page 141)
	MEMORY	You can read and save internal memory settings and measured data.	❖ 9.1 "Using the Internal Memory"(page 142)
	PC-CARD	You can read and save PC card settings and measured data.	❖ 9.2 "Using a PC Card"(page 143)

VIEW Screen

	WAVE	
	VOLT/CURR	Displays voltage and current waveforms. You can display entire waveforms or enlarged parts of waveforms.
	VOLTAGE	Displays 4 channels of voltage waveforms.
	CURRENT	Displays 4 channels of current waveforms.

❖ 5.2 "Waveform Display"(page 67)

	VECTOR	Displays voltage and current vector diagrams. Displays the numerical value for RMS and the unbalance factor.
---	---------------	--

❖ 5.3 "Vector Display"(page 70)





	DMM	
	POWER	Displays voltage, current, active power, reactive power, apparent power, and power factor values.
	VOLTAGE	Displays voltage, voltage unbalance factor, and total voltage distortion values.
	CURRENT	Displays current, current waveform peak value, current unbalance factor, and the total current distortion values.

❖ 5.4 "DMM Display"(page 73)

	HARMONICS	
	GRAPH	Displays the voltage, current, and active power bar graphs simultaneously.
	LIST	Displays the harmonics list selected from voltage, current, or active power.

❖ 5.5 "Harmonics Display"(page 74)

TIME PLOT Screen

	RMS		❖ 6.3 "Changes in RMS Value"(page 89)
	1 ELEMENT	You can select one measurement item and display RMS time series graphs for each measurement interval of 200 ms.	
	2 ELEMENT	You can select two measurement items and display RMS time series graphs for each measurement interval of 200 ms.	
	VOLTAGE		❖ 6.4 "Changes in Voltage"(page 93)
	INTERVAL	Displays a time series graph for the voltage measured in one waveform shifted over half a wave for each measurement interval.	
	EVENT	Displays a half cycle-shifted, 10-second time series graph for a voltage event in a single waveform.	
	HARMONICS		❖ 6.5 "Changes in Harmonics"(page 100)
	HARM	You can select 6 orders and display it in a harmonics time series graph.	
	INTERHARM	You can select 6 orders and display the inter-harmonics.	
	FLICKER		❖ 6.6 "Flicker"(page 104)
	GRAPH	Displays a time series graph for IEC flicker or ΔV_{10} flicker.	
	LIST	Displays a list of IEC flicker or ΔV_{10} flicker statistics.	

EVENT Screen

	EVENT	
	LIST	Displays the contents of events in the event list.
	MONITOR	Displays an LED on the monitor display when an event occurs.

❖ 7.4 "Event List Display"(page 127)

❖ 7.7 "Event Monitor Display"(page 134)

	EN50160	
	Overview	Displays judgment results for all measurement items, in accordance with the EN50160.

❖ See the Instruction Manual for the EN50160

	EN50160	
	Harmonics	Displays detailed judgment results for harmonics, in accordance with the EN50160.
	Signaling	Displays detailed judgment results for signaling voltage, in accordance with the EN50160.
	Events	Displays detailed judgment results for events, in accordance with the EN50160.

❖ See the Instruction Manual for the EN50160

	EN50160	
	Setting1	Sets the wiring, voltage range, PT ratio, nominal voltage, and thresholds of transient, swell, dip, and interruption, in accordance with the EN50160.
	Setting2	Sets the thresholds of frequency, voltage fluctuation, flicker, unbalance factor, THD, signaling voltage, in accordance with the EN50160.
	Setting3	Sets the thresholds of harmonic waveform, in accordance with the EN50160.

❖ See the Instruction Manual for the EN50160

2.2.3 Screen Details

SYSTEM WIRING SYSTEM Screen

Press **DF1** to switch the display screen.

DF1

WIRING

4.2.1 "Confirming the Connection Diagram"(page 45)

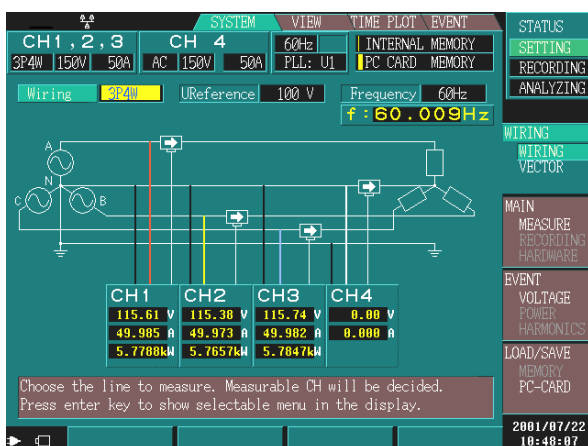

Connection diagram corresponding to the connection method

Displays (the connection methods for the voltage cord and clamp and) the voltage value, current value, and active power value for each channel.

❖ When the display value is wrong(page 46)

VECTOR

4.2.2 "Checking the Connection"(page 47)

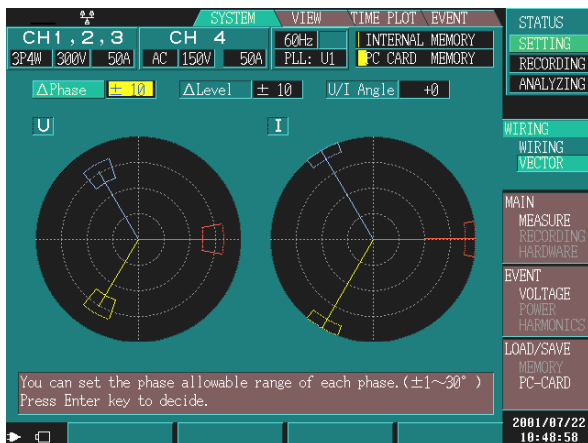

Displays the vector diagrams of voltage and current so that you can check the vectors.

This allows you to determine the RMS levels and phase differences between channels.

❖ Setting tolerance levels(page 47)
❖ Tolerance levels are wrong(page 48)

SYSTEM

MAIN

SYSTEM Screen

Press **DF2** to switch the display screen.

DF2

MEASURE

4.3.1 "Main Settings"(page 49)

SYSTEM		VIEW	TIME PLOT	EVENT	STATUS
CH 1, 2, 3	CH 4	60Hz	INTERNAL MEMORY		SETTING
3P4W 150V 50A	AC 150V 50A	PLL: U1	PC CARD	MEMORY	RECORDING
					ANALYZING
Wiring	123ch 4ch	UReference	120 V		WIRING
Clamp	1mV/A 9661 1mV/A 9661	Frequency	60Hz		WIRING VECTOR
U Range	150V 150V	PLL Source	U1		MAIN
PT Ratio	1 1	U CalcType	PHASE-N		MEASURE
I Range	50A 50A	Harm Calc	LEVEL		RECORDING
CT Ratio	1 1	THD Calc	THD F		HARDWARE
		PF Type	PF		EVENT
		Flicker	ΔV10		VOLTAGE
		TimePlot U	Urms		POWER
		Flicker CH	U1		HARMONICS
		EN50160	OFF		LOAD/SAVE
					MEMORY
					PC-CARD
Choose the line to measure. Measurable CH will be decided. Press enter key to show selectable menu in the display.					2001/07/22 11:30:53

You can make basic measurement settings for the following.

- Connection method
- Voltage and current ranges
- PT and CT ratios
- Clamp sensor
- Nominal voltage
- Measured frequency
- PLL source
- Calculation method
- Flicker
- EN50160
- and so on

RECORDING

6.2 "Time Plot Settings"(page 81)

SYSTEM		VIEW	TIME PLOT	EVENT	STATUS
CH 1, 2, 3	CH 4	60Hz	INTERNAL MEMORY		SETTING
3P4W 150V 500mA	AC 150V 50A	PLL: U1	PC CARD	MEMORY	RECORDING
					ANALYZING
Rec. Data	MIN DATA	MAX/MIN/AVE			WIRING
MemoryFull	STOP				WIRING VECTOR
Interval	1 sec	00 00:05:45			MAIN
Auto Save	BINARY				MEASURE
Time Start	OFF				RECORDING
RepeatSave	OFF	99 times			HARDWARE
Start Time	2002 Y 9 M 5 D 0 h 0 m				EVENT
Stop Time	2002 Y 9 M 11 D 23 h 59 m				VOLTAGE
You can decide items to save in Time Plot measurement. You can select one from Power, P&Harm, ALL.					LOAD/SAVE
					MEMORY
					PC-CARD
					2002/09/17 16:15:43

You can make recording settings for the following.

- TIME PLOT (time series) data selection
- Measurement interval
- Auto-save to the PC card
- Real-time control
- Measurement start and end times
- Repeated recording
- and so on

HARDWARE

4.3.3 "Hardware Settings"(page 59)

SYSTEM		VIEW	TIME PLOT	EVENT	STATUS
CH 1, 2, 3	CH 4	60Hz	INTERNAL MEMORY		SETTING
3P4W 300V 500A	AC 300V 500A	PLL: U1	PC CARD	MEMORY	RECORDING
					ANALYZING
Version	Ver 1.40				WIRING
Language	English				WIRING VECTOR
Beep	ON				MAIN
Color	COLOR 1				MEASURE
LCD Off	ON				RECORDING
Clock	2005 Y 9 M 2 D 11 h 0 m 56 s				HARDWARE
Smart Site	OFF				EVENT
RS-232C	OFF	57600bps			VOLTAGE
Timer	OFF	1 min			POWER
IP Address	192 . 168 . 0 . 1				HARMONICS
Net Mask	255 . 255 . 255 . 0	00:01:67:00:07:62			LOAD/SAVE
System Reset					MEMORY
You can decide the language to show.					PC-CARD
					2005/09/02 11:01:01

You can set the following hardware information.

- Display language
- Beep
- Screen color
- Clock settings
- RS-232C
- Automatic hard copy
- LAN
- and so on

SYSTEM

EVENT

SYSTEM Screen

Press **DF3** to switch the display screen.

DF3

VOLTAGE

7.3.1 "Voltage/Power Event Settings"(page 122)

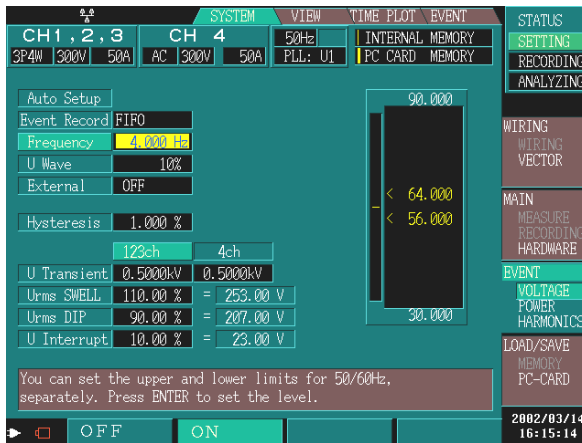

Select the event triggers and set the thresholds.

You can set the following as events.

- Transient
- Swell
- Dip
- Interruption
- Frequency
- Voltage waveform comparison

POWER

7.3.1 "Voltage/Power Event Settings"(page 122)



Select the event triggers and set the thresholds.

You can set the following as events.

- Voltage and current RMS values
- Voltage and current waveform peak values
- Active power
- Reactive power
- Apparent power
- Power factor
- K factor
- Voltage and current distortion factors
- Voltage and current unbalance factors

HARMONICS

7.3.2 "Harmonics Event Setting"(page 126)

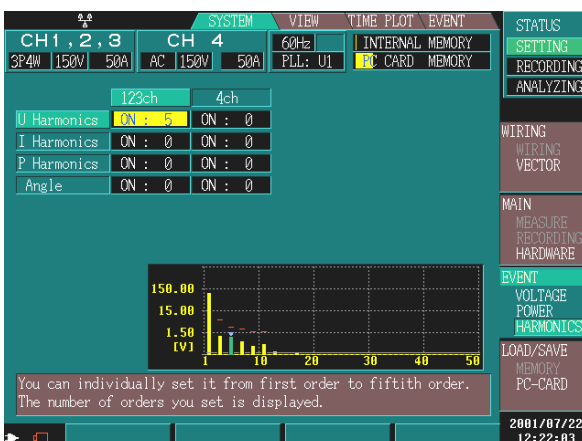

Select the event triggers and set the thresholds.

You can set the following as events.

- Voltage, current, and power harmonics
- Harmonics phase difference angle

SYSTEM **LOAD/SAVE** **SYSTEM Screen**

Press **DF4** to switch the display screen.



MEMORY

9.1 "Using the Internal Memory"(page 142)

No.	Date	Time	Name
1	06-24	11:47:09	TEST
2	06-24	11:47:25	A_LINE
3	06-24	11:47:51	B_LINE
4	06-24	11:48:08	C_LINE
5	06-24	11:55:45	AC_LOADS
6	06-24	11:51:50	TURBINE
7	06-24	11:52:06	UPS
8	06-24	11:53:25	CONTROL
9	06-24	11:54:21	UTILITY
10	06-24	11:58:43	ACSYSTEM

Displays the settings file list stored in this device's internal memory. You can load and save settings using this device's internal memory.

PC-CARD

9.2 "Using a PC Card"(page 143)

No.	File Name	Size	Date
1	B1110901	<DIR>	01-11-09 12:04
2	T1110902	<DIR>	01-11-09 12:04
3	H3196006	BMP 41742	01-11-09 12:03
4	TEST	SET 3904	01-11-09 12:03
5	TEXTWAVE	<DIR>	01-11-09 12:03

Displays the list of files stored on the PC card. You can load the measured data files and settings files stored on the PC card to the 3196, and then save them to the PC card again.

VIEW

WAVE

VIEW Screen

Press **DF1** to switch the display screen.

DF1

VOLT/CURR

5.2 "Waveform Display"(page 67)

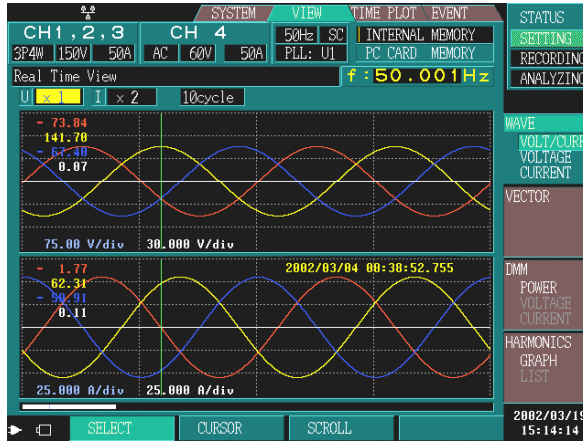

Displays voltage and current waveforms for channels, depending on how they are connected.

Displays 10 waveforms at 50 Hz, 12 waveforms at 60 Hz, and 80 waveforms at 400 Hz.

By scrolling when an event is selected, you can display 14 waveforms at 50 Hz, 16 waveforms at 60 Hz, and 112 waveforms at 400 Hz.

VOLTAGE

5.2 "Waveform Display"(page 67)

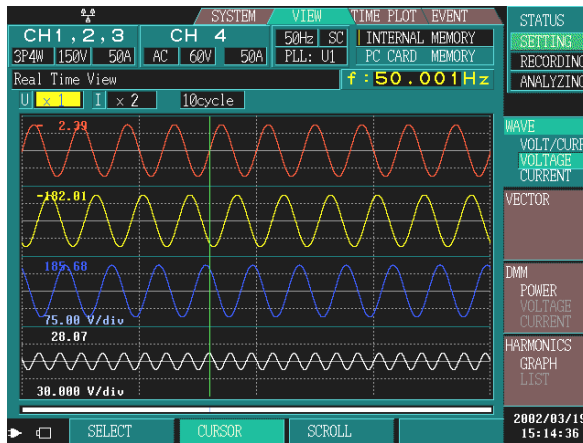

Displays voltage waveforms for channels, depending on how they are connected.

When three-phase 4-wire is selected, you can display voltage waveforms for 4 channels to identify the degree of phase rotation of each channel.

CURRENT

5.2 "Waveform Display"(page 67)

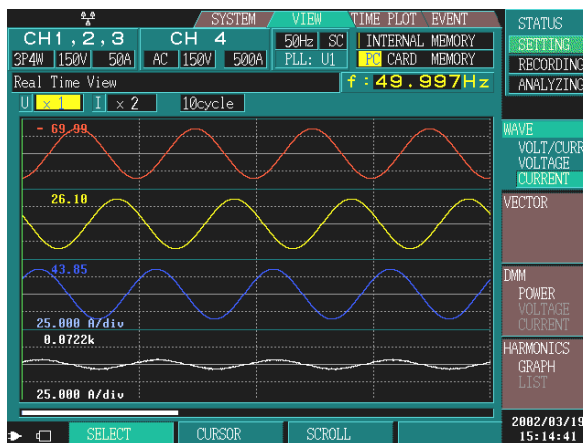

Displays current waveforms for channels, depending on how they are connected.

When three-phase 4-wire is selected, you can display current waveforms for 4 channels to identify the degree of phase rotation of each channel.

VIEW

VECTOR

VIEW Screen

Press **DF2** to switch the display screen.

DF2

VECTOR

5.3 "Vector Display"(page 70)

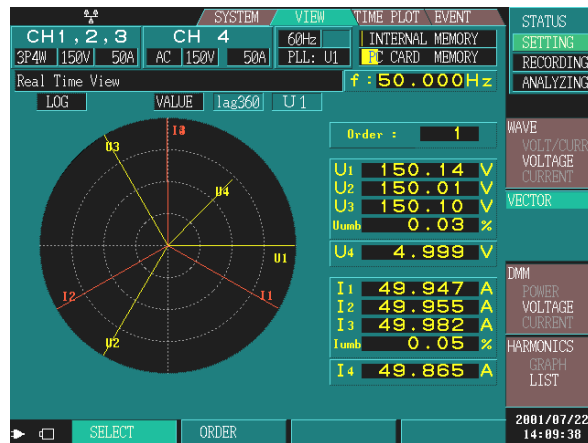

Displays voltage and current vectors for channels, depending on how they are connected.

You can display each order (1st to 50th order) for harmonic analysis as a vectors and simultaneously display the harmonic (RMS value or phase angle) and unbalance factors as numerical values.

For phase angle display, you can select $\pm 180^\circ$ display or 360° lag display. Up to 10th order harmonics can be displayed when measuring 400 Hz.

Example screen: Displays vectors for 4, 3P4W (three-phase four-wire) channels.

VIEW

DMM

VIEW Screen

Press **DF3** to switch the display screen.

DF3

POWER

5.4 "DMM Display"(page 73)

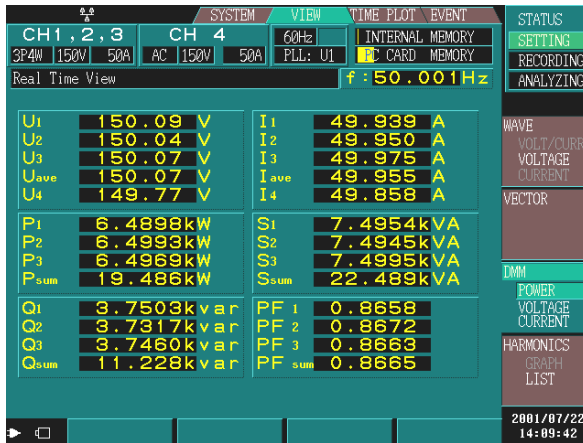

You can display the following items on the DMM display.

- Voltage (U)
- Current (I)
- Active power (P)
- Reactive power (Q)
- Apparent power (S)
- Power factor (PF) or displacement power factor (DPF)

Displays numerical values for channels, depending on how they are connected.

Example: Displays 4, 3P4W (three-phase four-wire) channels on the DMM display.

VOLTAGE

5.4 "DMM Display"(page 73)

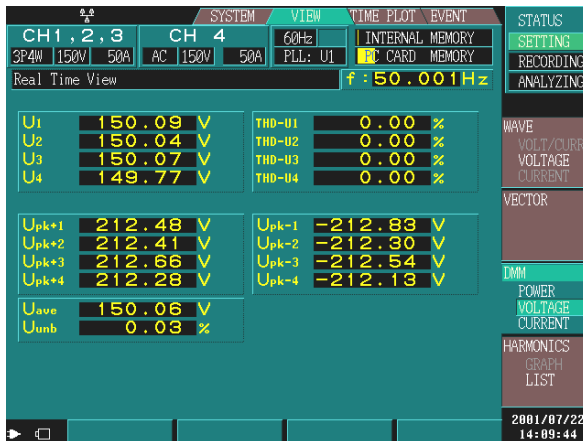

You can display the following items on the DMM display.

- Voltage
- Total voltage distortion
- Voltage waveform peak
- Average voltage value
- Voltage unbalance factor

Displays numerical values for channels on the DMM display, depending on how they are connected.

Example: Displays 4, 3P4W (three-phase four-wire) channels on the DMM display.

CURRENT

5.4 "DMM Display"(page 73)



You can display the following items on the DMM display.

- Current
- Total current distortion
- Current waveform peak
- Average current value
- Current unbalance factor

Displays numerical values for channels on the DMM display, depending on how they are connected.

Example: Displays 4, 3P4W (three-phase four-wire) channels on the DMM display.

VIEW

HARMONICS

VIEW Screen

Press **DF4** to switch the display screen.

DF4

GRAPH

5.5.1 "Harmonics Bar Graph"(page 74)



Displays a bar graph for the harmonics and inter-harmonics.

Displays three bar graphs for the voltage, current, and active power simultaneously.

Up to 10th order harmonics can be displayed when measuring 400 Hz.

LIST

5.5.2 "Harmonics List Screen"(page 76)

Order	Value	Order	Value	THD	
1:	96.55	2:	0.02	1.75	
3:	0.95	19:	0.09	35:	0.12
4:	0.00	20:	0.00	36:	0.01
5:	1.00	21:	0.03	37:	0.06
6:	0.01	22:	0.00	38:	0.00
7:	0.54	23:	0.09	39:	0.03
8:	0.01	24:	0.01	40:	0.00
9:	0.38	25:	0.18	41:	0.03
10:	0.01	26:	0.00	42:	0.00
11:	0.52	27:	0.10	43:	0.02
12:	0.00	28:	0.00	44:	0.00
13:	0.18	29:	0.16	45:	0.02
14:	0.00	30:	0.01	46:	0.00
15:	0.17	31:	0.16	47:	0.02
16:	0.01	32:	0.00	48:	0.00
17:	0.20	33:	0.09	49:	0.00
18:	0.00	34:	0.02	50:	0.00

Displays a list of the harmonics and inter-harmonics.

Displays the list and distortion of the selected display items simultaneously. Up to 10th order harmonics can be displayed when measuring 400 Hz.

TIME PLOT

RMS

TIME PLOT Screen

Press **DF1** to switch the display screen.

DF1

1 ELEMENT

6.3 "Changes in RMS Value"(page 89)

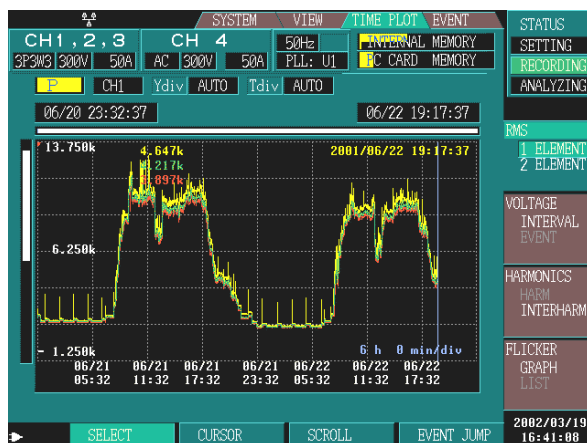

You can display the fluctuation graph of a single RMS value selected from the following.

- Frequency
- Voltage
- Voltage waveform peak
- Current
- Current waveform peak
- Active power
- Apparent power
- Reactive power
- Power factor
- K factor
- Voltage unbalance factor
- Current unbalance factor
- Harmonic voltage distortion factor
- Harmonic current distortion factor

RMS values are calculated ^{*1} in the 3196 at 200 ms intervals without gaps. The maximum, average, and minimum values are detected using the multiple 200 ms interval RMS values included in the set interval, and the display changes.

2 ELEMENT

6.3 "Changes in RMS Value"(page 89)

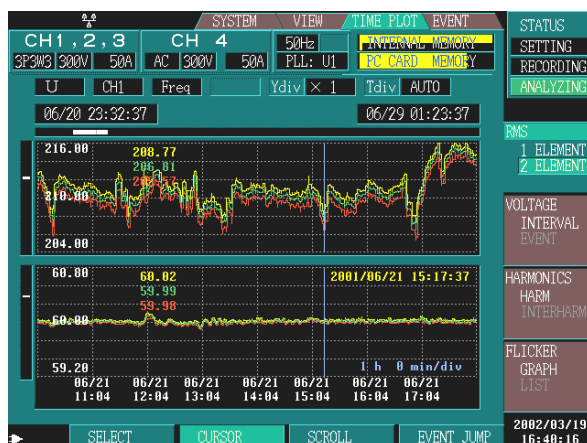

You can display a fluctuation graph for two RMS values selected from the following.

- Frequency
- Voltage
- Voltage waveform peak
- Current
- Current waveform peak
- Active power
- Apparent power
- Reactive power
- Power factor
- K factor
- Voltage unbalance factor
- Current unbalance factor
- Harmonic voltage distortion factor
- Harmonic current distortion factor

*1: Calculated without gaps. Continuous RMS value calculations at 200 ms intervals (50 Hz: 10 waveforms, 60 Hz: 12 waveforms, 400 Hz: 80 waveforms).

RMS values are calculated ^{*1} in the 3196 at 200 ms intervals without any gaps. The maximum, average, and minimum values are detected from the multiple 200 ms interval RMS values included in the set interval, and the display changes.

TIME PLOT

VOLTAGE

TIME PLOT Screen

Press **DF2** to switch the display screen.

DF2

INTERVAL

6.4 "Changes in Voltage"(page 93)

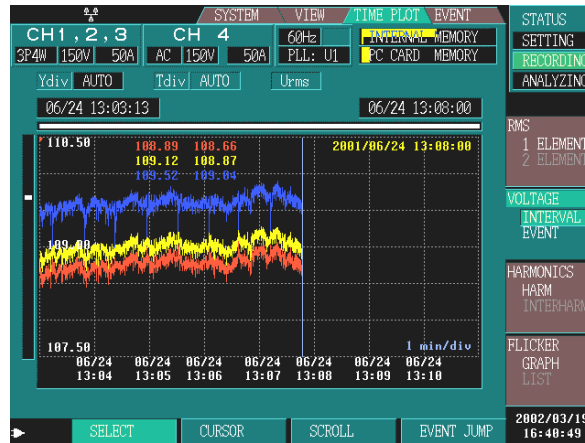

Displays a voltage fluctuation graph used to calculate the swell, dip, and interruption.

Voltage is calculated for one waveform shifted over half a wave.

The maximum and minimum values are detected from the multiple voltage values included in the set interval, and the display changes.

You can also display $S(t)$ (when IEC flicker is selected) or ΔU (when DV10 flicker is selected), either of which indicates the voltage deviation with respect to nominal voltage.

EVENT

6.4.2 "Graphing Voltage Fluctuations for Events"(page 96)

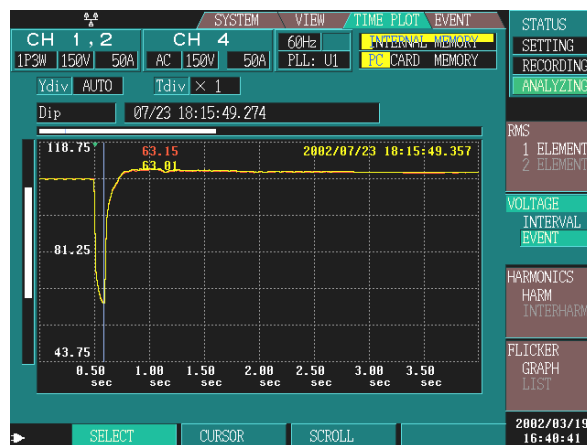

Displays the voltage fluctuation graph for a voltage swell, dip, or interruption event.

The result of calculation for a single half cycle-shifted waveform is displayed without alteration as a voltage fluctuation graph.

Pre-trigger is fixed to 0.5 second and recording length to 10 seconds.

Although only one fluctuation graph is stored in internal memory, you can read multiple fluctuation graphs by using a PC card.

TIME PLOT

HARMONICS

TIME PLOT Screen

DF3

HARM

6.5 "Changes in Harmonics"(page 100)

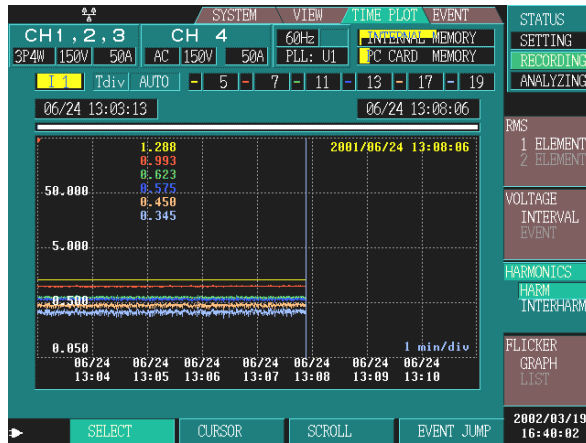

You can display a fluctuation graph for a single harmonic selected from the following.

- Harmonic voltage (RMS value, content percentage, and phase angle)
- Harmonic current (RMS value, content percentage, and phase angle)
- Harmonic power (RMS value and phase difference)

You can select 6 orders to be displayed simultaneously from orders 1 to 50 for the basic wave.

Recorded data is not displayed unless it is shown in P&Harm or ALL DATA in **[SYSTEM]-DF2[RECORDING]**.

Up to 10th order harmonics can be displayed when measuring 400 Hz.

INTERHARM

6.5 "Changes in Harmonics"(page 100)



You can display a fluctuation graph for a single inter-harmonic selected from the following.

- Inter-harmonic voltage (RMS value and content percentage)
- Inter-harmonic current (RMS value and content percentage)

This cannot be displayed when measuring 400 Hz.

You can select 6 orders to be displayed simultaneously from 0.5th to 49.5th order.

Recorded data is not displayed unless it is shown in P&Harm or ALL DATA in **[SYSTEM]-DF2[RECORDING]**.

2.2 Screen Names and Configurations

Flicker analysis is not available when measuring 400 Hz.

TIME PLOT

FLICKER

TIME PLOT Screen

DF 4

GRAPH

6.6 "Flicker"(page 104)

Displays a graph for IEC flicker or ΔV_{10} flicker
IEC Flicker

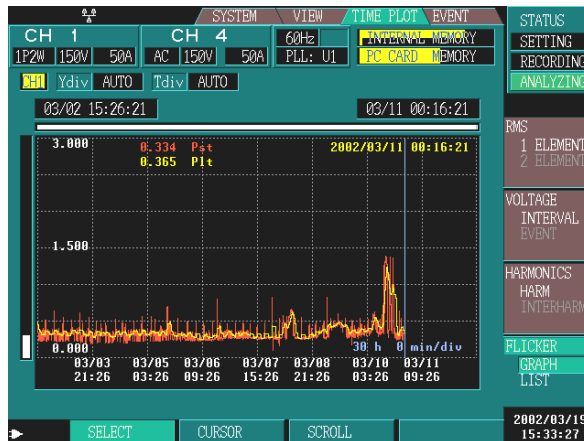

Displays a fluctuation graph for IEC flicker (Pst, Plt).

The graph is updated every 10-minute, regardless of the interval that is set for **[SYSTEM] - DF2 [MAIN] - [RECORDING]**.

This is only displayed if Pst, Plt is selected for flicker in **[SYSTEM] - DF2 [MAIN] - [MEASURE]**.

ΔV_{10} Flicker



Displays a fluctuation graph for ΔV_{10} flicker.

The graph is updated once a minute, regardless of the interval that is set for **[SYSTEM] - DF2 [MAIN] - [RECORDING]**.

This is only displayed if ΔV_{10} is selected for flicker in **[SYSTEM] - DF2 [MAIN] - [MEASURE]**.

2.2 Screen Names and Configurations

Flicker analysis is not available when measuring 400 Hz.



FLICKER

TIME PLOT Screen



LIST

6.6 "Flicker"(page 104)

Displays a list for IEC flicker or $\Delta V10$ flicker

IEC Flicker

No.	Date	Time	Pst	Plt
1196	03-10	22:46:21	0.238	0.411
1197	03-10	22:56:21	0.302	0.409
1198	03-10	23:06:21	0.337	0.413
1199	03-10	23:16:21	0.229	0.410
1200	03-10	23:26:21	0.304	0.369
1201	03-10	23:36:21	0.331	0.369
1202	03-10	23:46:21	0.318	0.365
1203	03-10	23:56:21	0.356	0.370
1204	03-11	00:06:21	0.620	0.386
1205	03-11	00:16:21	0.334	0.365

Displays the IEC flicker (Pst, Plt) values in a list.

- Pst (short interval voltage flicker)
- Plt (long interval voltage flicker)

The list is updated every 10-minute.

This is only displayed if Plt, Pst is selected for flicker in **[SYSTEM] - DF2 [MAIN] - [MEASURE]**.

$\Delta V10$ Flicker

No.	Date	Time	$\Delta V10_{max}$ [V]	$\Delta V10_{max4}$ [V]	ave [V]
1	10-12	19:40:00	0.127	0.096	0.081
2	10-12	20:40:00	0.100	0.081	0.074
3	10-12	21:40:00	0.092	0.081	0.073
4	10-12	22:40:00	0.081	0.079	0.072
5	10-12	23:40:00	0.080	0.073	0.068
6	10-13	00:40:00	0.077	0.070	0.063
7	10-13	01:40:00	0.069	0.063	0.056
8	10-13	02:40:00	0.072	0.054	0.050
9	10-13	03:40:00	0.076	0.052	0.049
10	10-13	04:40:00	0.054	0.051	0.047

TOTAL MAX 0.186 V

Displays the $\Delta V10$ statistics below in a list.

- The maximum value over one hour for $\Delta V10$ Flicker
- The fourth maximum value over one hour for $\Delta V10$ Flicker
- The average value over one hour for $\Delta V10$ Flicker
- Overall maximum value for $\Delta V10$ Flicker

The statistics are updated once an hour.

This is only displayed if $\Delta V10$ is selected for flicker in **[SYSTEM] - DF2 [MAIN] - [MEASURE]**.

EVENT **EVENT** **EVENT Screen**

DF1

LIST

7.4 "Event List Display"(page 127)

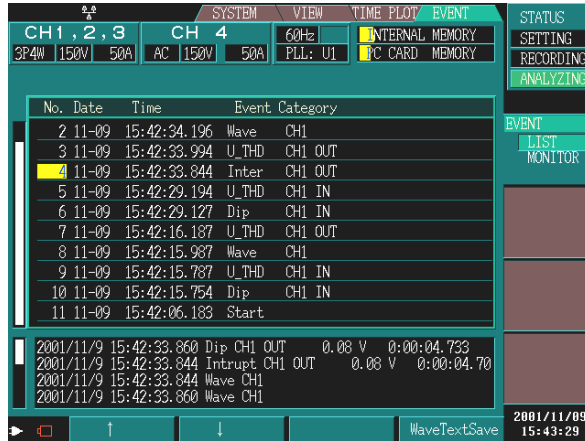

Displays events in a form list. You can confirm the time and type of event that occurred.

By selecting an event with the cursor, you can make a detailed analysis of the event in the VIEW Screen.

You can select the time sequence and priority sequence for the list display method.

MONITOR

7.7 "Event Monitor Display"(page 134)



You can monitor if any events occurred and how many of each type of event.

EN50160 display is not available when measuring 400 Hz.

EVENT **EN50160** **EVENT Screen**

DF2

Overview



Displays judgment results for all measurement items, in accordance with the EN50160.

2.2 Screen Names and Configurations

EN50160 display is not available when measuring 400 Hz.



EN50160

EVENT Screen



Harmonics

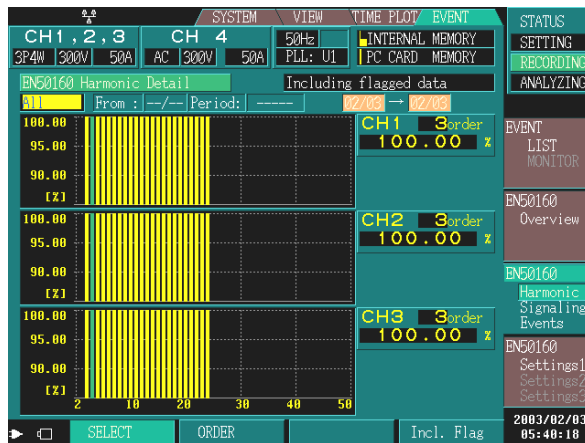

Displays detailed judgment results for harmonics, in accordance with the EN50160.

Signaling

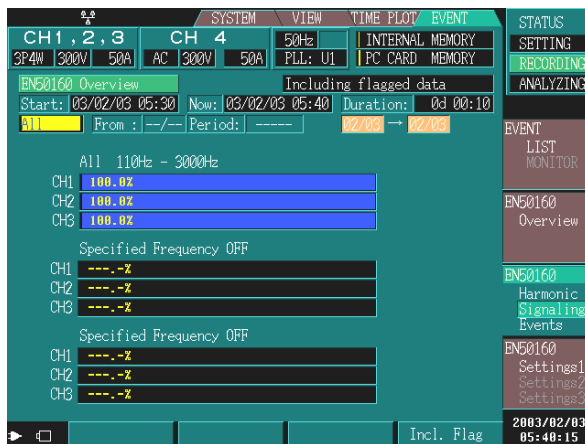

Displays detailed judgment results for signaling voltage, in accordance with the EN50160.

Events



Displays detailed judgment results for events, in accordance with the EN50160.

EN50160 display is not available when measuring 400 Hz.

EVENT **EN50160** **EVENT Screen**



Setting1

CH 1, 2, 3	CH 4	50Hz	INTERNAL MEMORY	STATUS
3P4W 300V 50A	AC 300V 50A	PLL: U1	PC CARD MEMORY	SETTING
Default				RECORDING
Wiring	3P4W			ANALYZING
U Range	300V			EVENT LIST MONITOR
PT Ratio	1			EN50160 Overview
UReference	230 V			EN50160 Harmonic Signaling Events
U Transient	180.00 %			EN50160 Settings1
Urms SWELL	110.00 % = 253.00 V			Settings2
Urms DIP	90.00 % = 207.00 V			Settings3
U Interrupt	1.000 % = 2.30 V			2002/12/25 11:47:36
Short int T	180.00 s			
All EN50160 settings have been reset to the default values. Press F1 key to decide.				
Default				

Sets the wiring, voltage range, PT ratio, nominal voltage, and thresholds of transient, swell, dip, and interruption, in accordance with the EN50160.

Setting2

CH 1, 2, 3	CH 4	50Hz	INTERNAL MEMORY	STATUS
3P4W 300V 50A	AC 300V 50A	PLL: U1	PC CARD MEMORY	SETTING
Threshold Good %				RECORDING
Freq. A(±)	1.000 %	99.50 %		ANALYZING
Freq. B +	6.000 %	100.00 %		EVENT LIST MONITOR
Freq. B -	-4.000 %	↑		EN50160 Overview
V Vari. A(±)	10.000 %	95.00 %		EN50160 Harmonic Signaling Events
V Vari. B +	10.000 %	100.00 %		EN50160 Settings1
V Vari. B -	-15.000 %	↑		Settings2
Flicker	1.000	95.00 %		Settings3
Unbalance	2.00 %	95.00 %		2002/12/25 11:47:38
THD	8.00 %	95.00 %		
Signaling p1	0.5000kHz	99.00 %		
Signaling p1	9.00 %	↑		
Signaling p2	1.0000kHz	↑		
Signaling p2	5.00 %	↑		
Signal spec1	OFF	↑		
Signal spec2	OFF	↑		

Sets the thresholds of frequency, voltage fluctuation, flicker, unbalance factor, THD, signaling voltage, in accordance with the EN50160.

Setting3

CH 1, 2, 3	CH 4	50Hz	INTERNAL MEMORY	STATUS						
3P4W 300V 50A	AC 300V 50A	PLL: U1	PC CARD MEMORY	SETTING						
EN50160 Harmonic Settings [% of Un]				RECORDING						
h 1	OFF	h11	3.50%	h21	0.50%	h31	OFF	h41	OFF	EVENT LIST MONITOR
h 2	2.00%	h12	0.50%	h22	0.50%	h32	OFF	h42	OFF	EN50160 Overview
h 3	5.00%	h13	3.00%	h23	1.50%	h33	OFF	h43	OFF	EN50160 Harmonic Signaling Events
h 4	1.00%	h14	0.50%	h24	0.50%	h34	OFF	h44	OFF	EN50160 Settings1
h 5	6.00%	h15	0.50%	h25	OFF	h35	OFF	h45	OFF	Settings2
h 6	0.50%	h16	0.50%	h26	OFF	h36	OFF	h46	OFF	Settings3
h 7	5.00%	h17	2.00%	h27	OFF	h37	OFF	h47	OFF	2002/12/25 11:47:59
h 8	0.50%	h18	0.50%	h28	OFF	h38	OFF	h48	OFF	
h 9	1.50%	h19	1.50%	h29	OFF	h39	OFF	h49	OFF	
h10	0.50%	h20	0.50%	h30	OFF	h40	OFF	h50	OFF	
Harm Good%				95.00 %						
OFF				ON						

Sets the thresholds of harmonic waveform, in accordance with the EN50160.

Connections

Chapter 3

For details about connection precautions, Refer to the Quick Start Manual.

1. Connecting to the 3196 POWER QUALITY ANALYZER

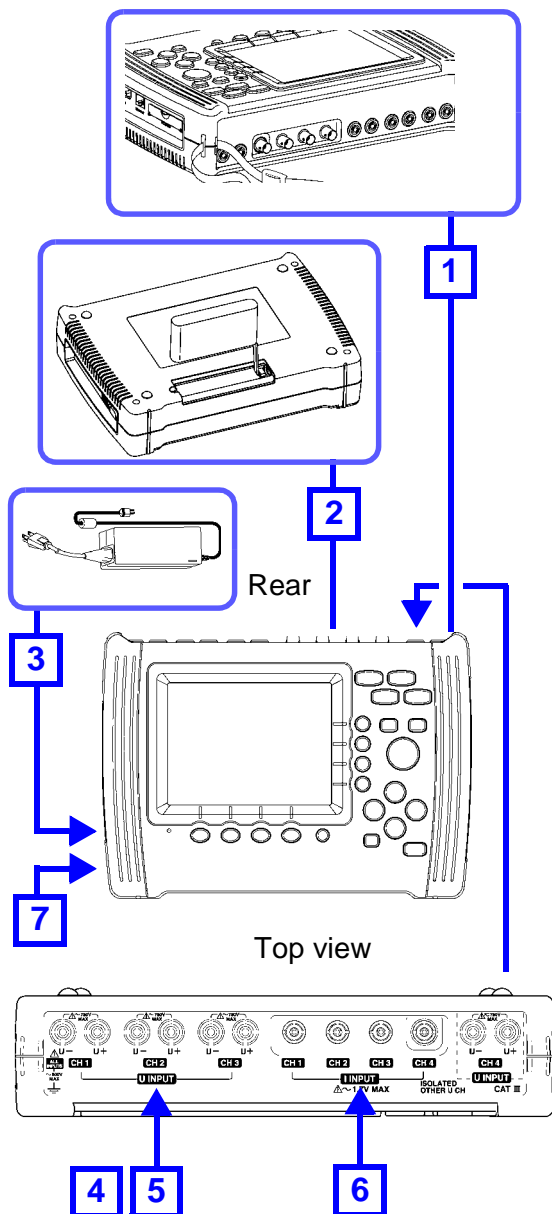

1 Attach the Strap.

*If unnecessary, go to step 2.

2 Install the battery pack.

3 Connect the AC adapter and power cord.

4 Connect the Wiring Adapter (optional). When not connecting the Wiring Adapter, go to step 5.

5 Connect the voltage cord. (Use the input cord label.)

6 Connect the clamp sensor. (Use the input cord label.)

7 Turn on the 3196.

Before connecting to the power line that you want to measure, make sure that you perform steps 1 to 7.

Connect to the power line that you want to measure. (to the next page)

2. Connecting to the target power line.

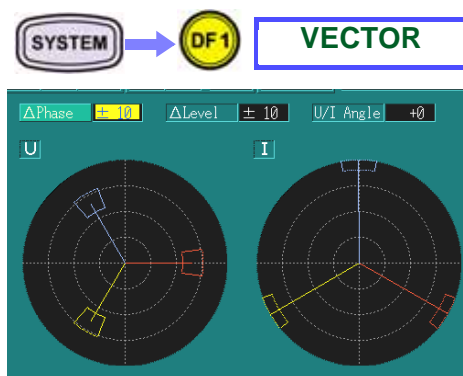
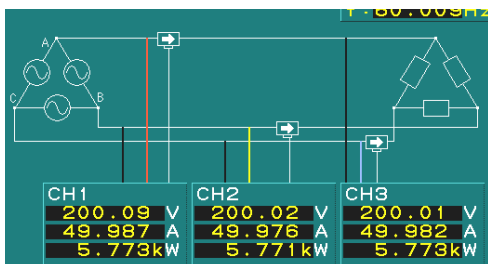
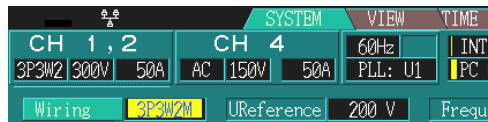

1 Set the connection method, nominal voltage, and frequency.

❖4.2 "Checking the Connection"(page 45)

2 While consulting the connection diagram, connect the voltage cord and clamp sensor to the power line that you want to measure.

3 Confirm the present connection status.

(voltage, current, and active power on each channel)

❖4.2.1 "Confirming the Connection Diagram"(page 45)

4 Check the connection status and set the tolerance levels.

(Check the oscillation and phase for the voltage and current in the vector.)

❖4.2.2 "Checking the Connection"(page 47)

5 Depending on your application, make recording and event settings.

Measurement/analysis

❖Chapter 4 "Making System Settings (SYSTEM Screen)"(page 43)

❖Chapter 5 "Using Waveforms, Vectors, DMMs, and Bar Graphs (VIEW Screen)"(page 65)

❖Chapter 6 "Using the Time Series Graph (TIME PLOT Screen)"(page 79)

❖Chapter 7 "Using Events (EVENT Screen)"(page 115)

3.1 Connection Diagram

Single-phase 2-wire (1P2W)

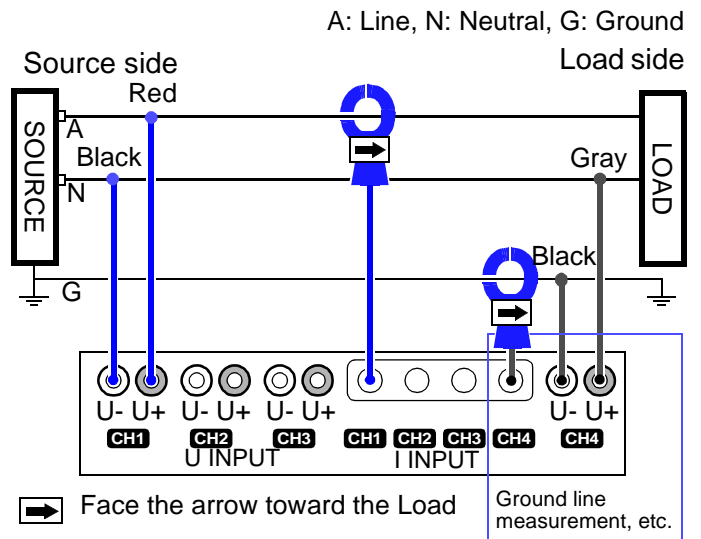
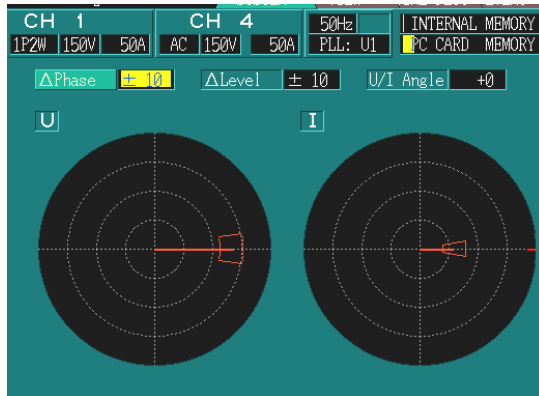
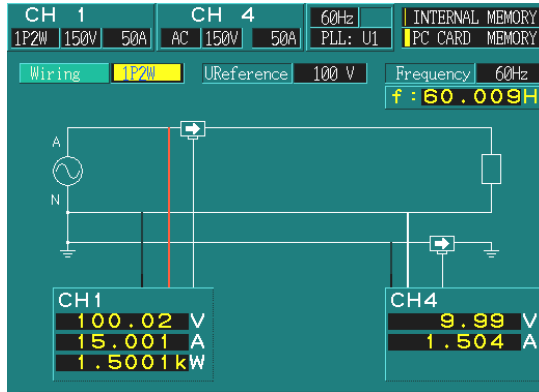

U1=100 V
 I1=15 A
 U4=10 V
 I4=1.5 A

Single-phase 3-wire (1P3W)

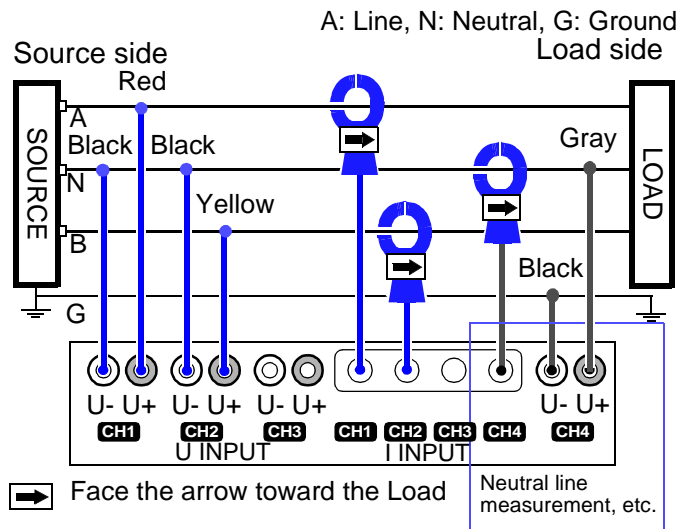
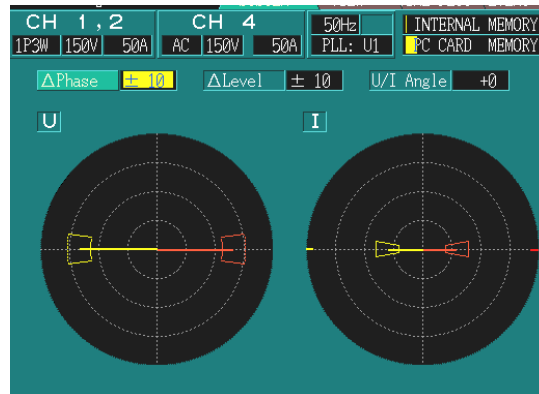
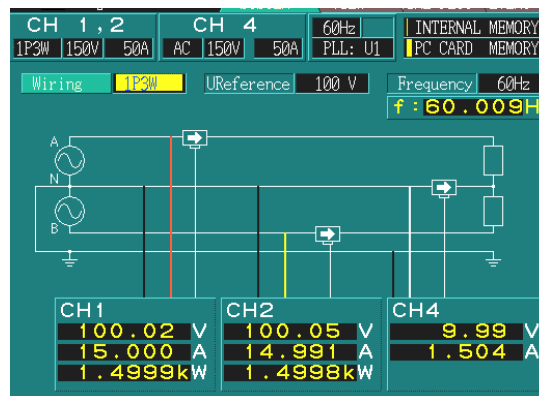

U1=U2=100 V
 I1=I2=15 A
 U4=10 V
 I4=1.5 A

3.1 Connection Diagram

Three-phase 3-wire (3P3W2M)

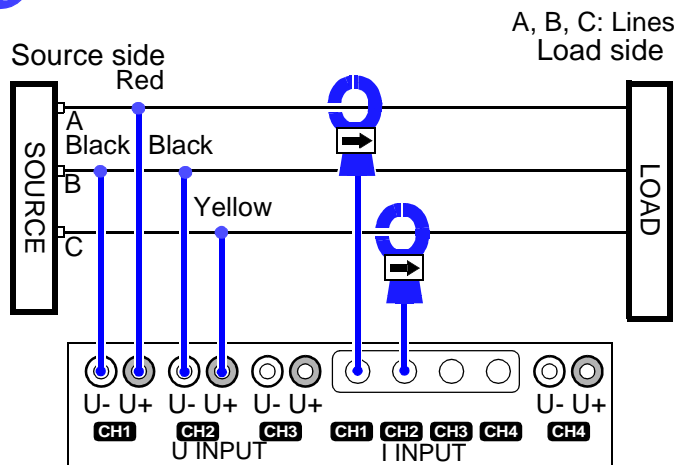
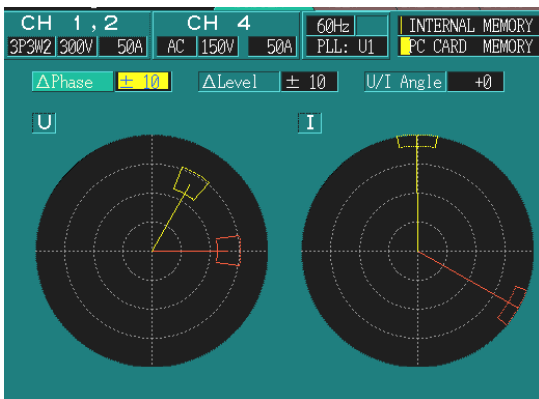
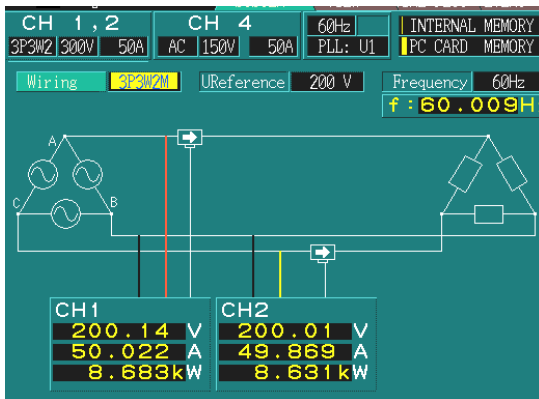

➔ Face the arrow toward the Load

$U1=U2=200\text{ V}$
 $I1=I2=50\text{ A}$

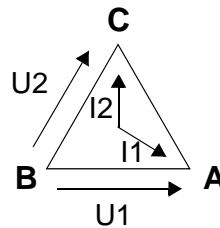

Three-phase 3-wire (3P3W3M)

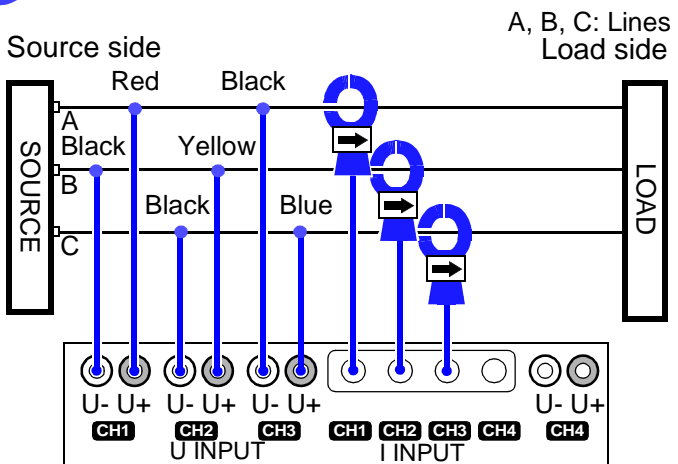
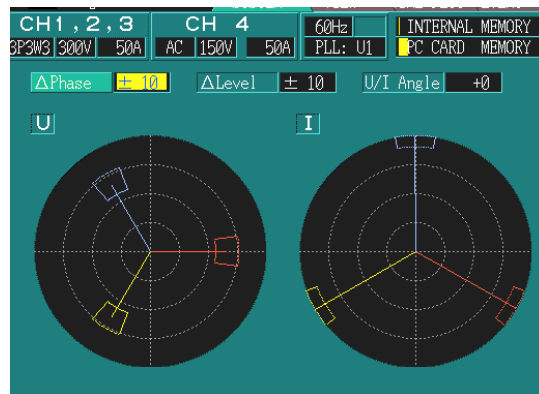
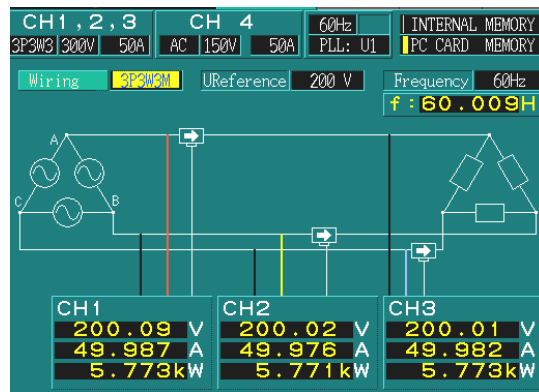

➔ Face the arrow toward the Load

$U1=U2=U3=200\text{ V}$
 $I1=I2=I3=50\text{ A}$

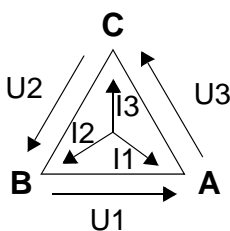

Three-phase 4-wire (3P4W)

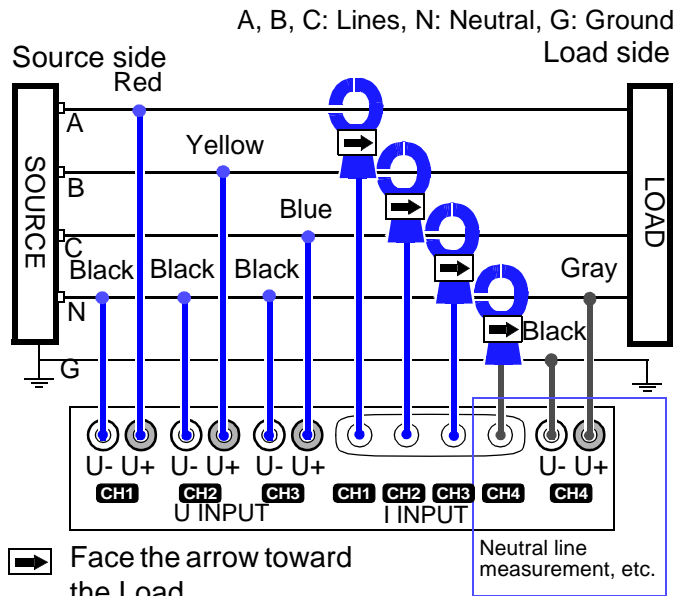
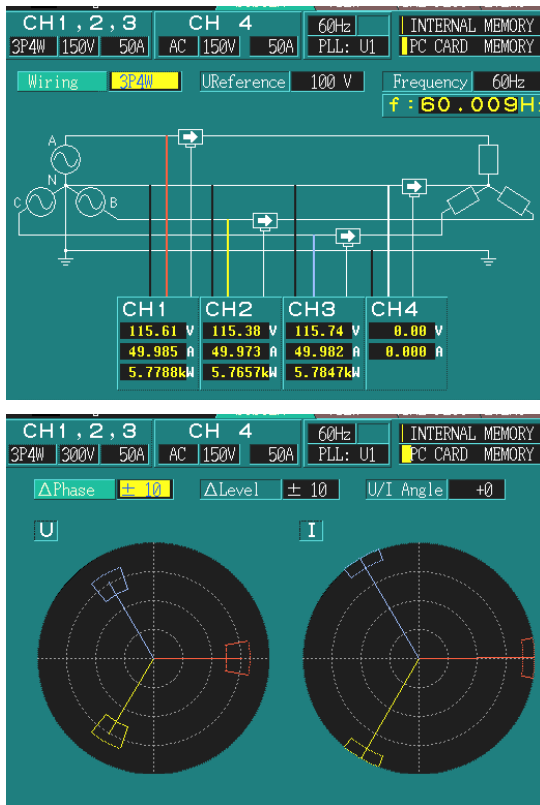

U1=U2=U3=115.5 V
I1=I2=I3=50 A
U4=0 V
I4=0 A

2 systems

1 system and DC power supply

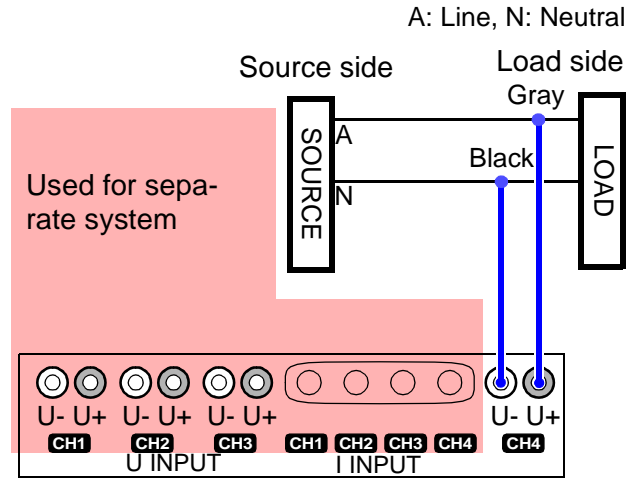
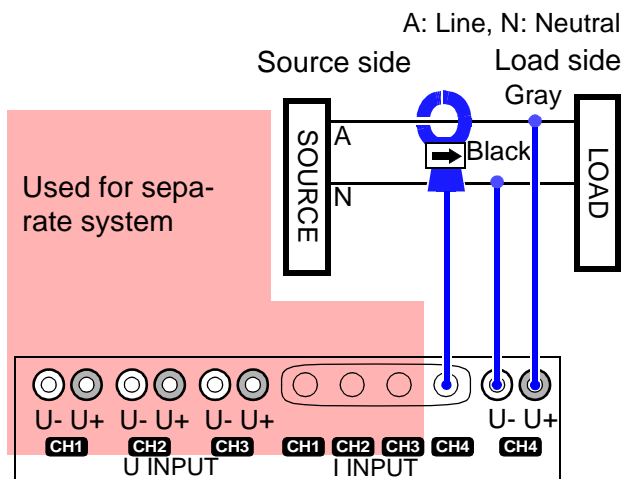

➡ Face the arrow toward the Load

Making System Settings

(SYSTEM Screen) *Chapter 4*

1. **Confirm the connection diagram.**
 - ❖ Confirming the Connection Diagram (page 45)
2. **Check the connection vectors.**
 - ❖ Checking the Connection (page 47)
3. **Make system settings.**
 - ❖ Making System Settings (page 49)

Make other settings in the SYSTEM screen.

- ❖ Event Settings Screen (page 63)
Using Events (EVENT Screen) (page 115)
- ❖ Load/Save Screen (page 64)
Loading and Saving Settings and Measured Data (page 141)

4.1 Using the SYSTEM Screen

Switching screen display

You can make settings for this device's system on the SYSTEM screen.

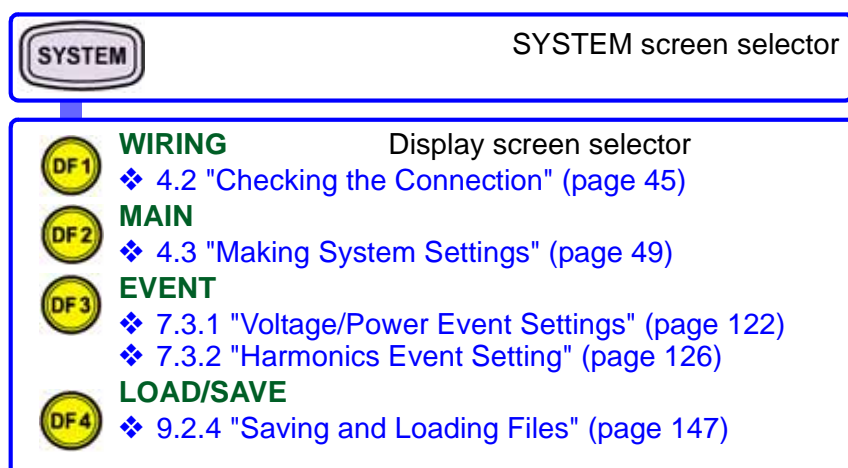

About the screen configuration

- ❖ 2.2.2 "Screen Configurations"(page 16)
- ❖ 2.2.3 "Screen Details"(page 20 to 23)

The SYSTEM screen is made up of a number of screens that correspond to the **DF1** to **DF4** (DF: display function) keys.

If you press a DF key, the screen corresponding to that key appears. Each time you press the same DF key, the display changes.

Screen operations depending on the internal operation status

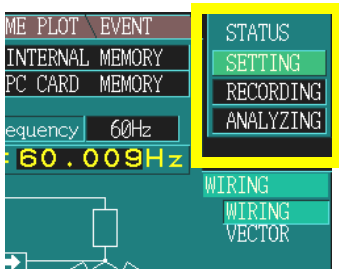

Screen operations are limited according to the internal operation status.

- : Possible on all screens
- *: Possible in some screens only

Internal operation status	Display	Settings
[SETTING]	●	●
[RECORDING]	●	*
[ANALYZING]	●	*



What is the relationship between the operation status and key operations?



The key does not start recording during [ANALYZING] operation!



Return to the setting mode from analysis Start recording

CAUTION!

Pressing erases all data stored in internal memory.



Changing settings while [RECORDING] or [ANALYZING] is displayed?

During [RECORDING] operation:



During [ANALYZING] operation:



In either case, data stored in internal memory is erased.

4.2 Checking the Connection

4.2.1 Confirming the Connection Diagram

SYSTEM



WIRING

WIRING

Example: 3P4W (three-phase four-wire)

CH1, 2, 3 CH 4 60Hz INTERNAL MEMORY
3P4W 150V 50A AC 150V 50A PLL: U1 PC CARD MEMORY

Wiring 3P4W UReference 100 V Frequency 60Hz
f : 60.009Hz

CH1 CH2 CH3 CH4
115.61 V 115.38 V 115.74 V 0.00 V
49.985 A 49.973 A 49.982 A 0.000 A

- ❖ Setting the connection method (page 45)
- ❖ Setting the nominal voltage (page 46)
- ❖ Setting the measured frequency (page 46)

Setting the connection method

SYSTEM

DF1

WIRING



Wiring

ENTER

Select from pull-down menu



ENTER

Confirm

ESC

Cancel

CH1, 2, 3 CH 4 60Hz INTERNAL MEMORY
3P4W 150V 50A AC 150V 50A PLL: U1 PC CARD MEMORY

Wiring 3P4W UReference 100 V Frequency 60Hz
f : 60.009Hz

1P2W

To measure single-phase two-wire power lines

1P3W

To measure single-phase three-wire power lines

3P3W2M

To measure single-phase three-wire power lines (using the 2 power meter method) (Use this when measuring three-phase power with 2-spot current measurement only.)

3P3W3M

To measure three-phase three-wire power lines (using the 3 power meter method)

3P4W

To measure three-phase four-wire power lines

Setting the nominal voltage



WIRING



U Reference

(Nominal voltage)



Select from pull-down menu



Confirm



Cancel

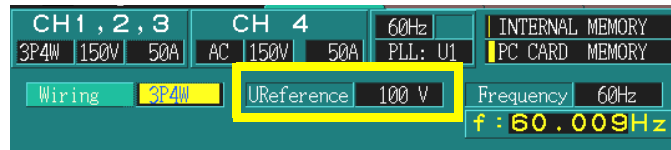

100 V, 101 V, 110 V, 120 V, 200 V, 202 V, 208 V, 220 V, 230 V, 240 V, 277 V, 346 V, 380 V, 400 V, 415 V, 480 V, 600 V, VARIABLE

Nominal voltage affects channels 1 to 3.

Setting the measured frequency



WIRING



Frequency

(Measured frequency)



Select from pull-down menu



Confirm



Cancel

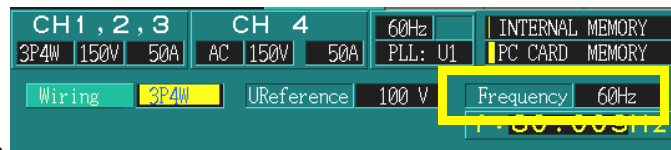

50 Hz, 60 Hz, 400 Hz

Inter-harmonics, flicker and EN50160 cannot be measured at 400 Hz.



When the display value is wrong

1. When the voltage or current display value is lower than expected

The voltage value is low:

- Is the voltage clip connected to the power line being tested?
- Is the voltage cord inserted in the voltage connector?

The current value is low:

- Is the clamp-on sensor inserted in the device's current connector?

2. When the active power display value is negative

- Is the voltage cord of the channel displaying the negative value connected properly?
- Is the arrow (printed on the clamp) on the clamp-on sensor for the channel displaying the negative value pointing to the loaded side?

3. When the voltage display value differs from the expected value of three-phase connections

- Are the phase-to-neutral voltage and line-to-line voltage (voltage calculation methods) selections different?

❖ "Voltage calculation method settings" (page 54)

4.2.2 Checking the Connection

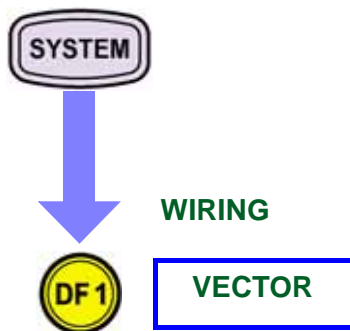

Example: 3P4W (three-phase four-wire)

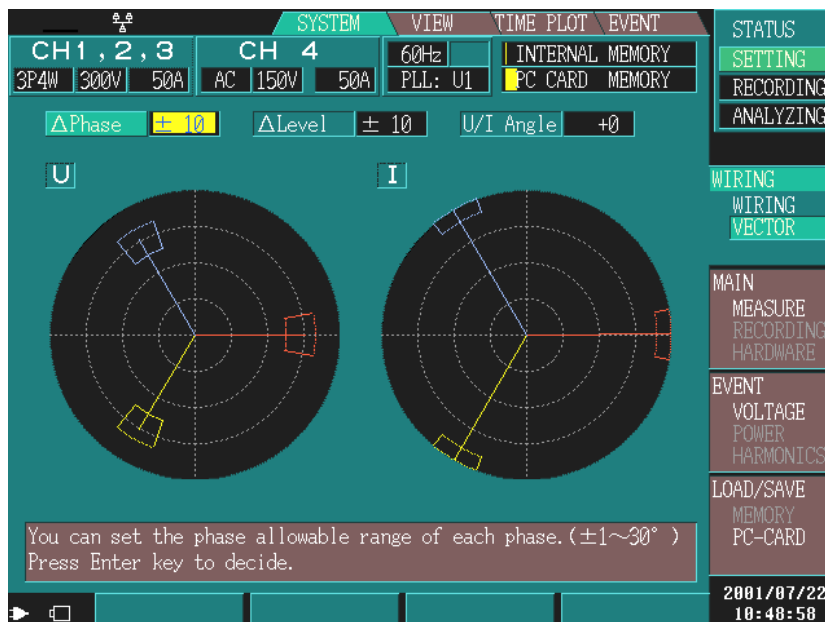

You can check the voltage and current vectors of each connection method.

When tolerance levels are set and the voltage or current falls outside these levels, check and correct the connection.

NOTE

When the input level is 50% or less of range, a marker is appended to the perimeter of the current vector to make it recognizable.

Setting tolerance levels

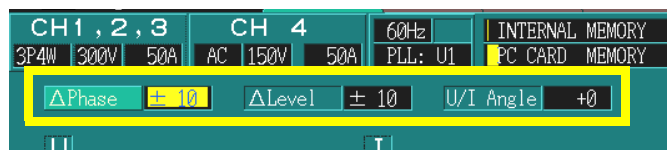
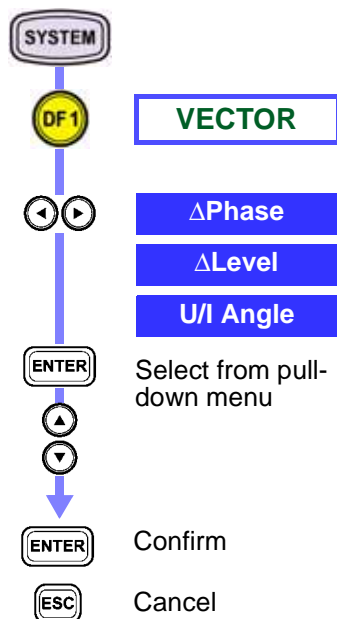

ΔPhase (Phase range)	Tolerance level of each phase in the phase range ±1 to 30°
ΔLevel (Oscillation range)	Tolerance level of each phase in the RMS value range ±1 to 30% Set the voltage relative to the nominal voltage, and the current relative to the range.
U/I Angle (UI phase differences)	Tolerance level of current phase differences in relation to voltage -60° to 60°



Tolerance levels are wrong

1. When the RMS voltage value is wrong

- Is the voltage clip properly connected to the power line being tested?
- Is the voltage cord inserted correctly in the voltage connector?

2. When the voltage phase angle is wrong

- Is the voltage cord connected properly?
- Are the colors on the voltage input terminal and the voltage cord the same?

3. When the RMS current value is wrong

- Is the clamp-on sensor properly inserted in the device's current connector?

4. When the current phase angle is wrong

- Is the arrow on the clamp sensor pointing towards the load?
- Are the current input terminal and clamp sensor connected properly?

4.3 Making System Settings

4.3.1 Main Settings

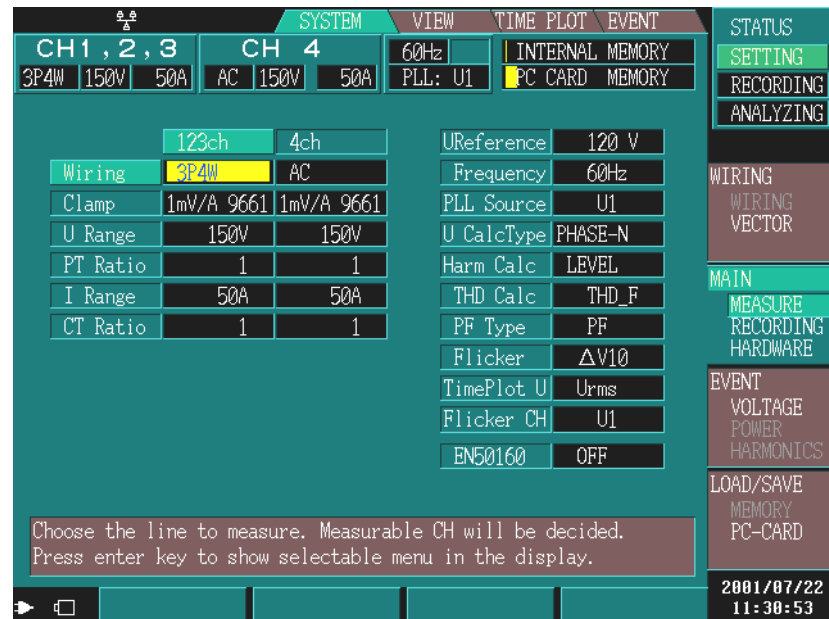
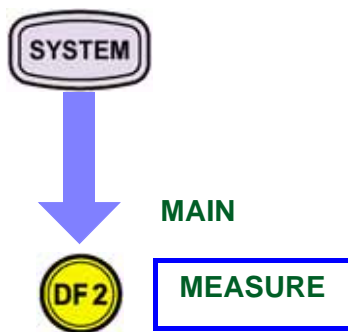

- ❖ Connection method settings (CH 1, 2, 3) (page 50)
- ❖ Connection method settings (CH 4) (page 50)
- ❖ Clamp sensor settings (page 51)
- ❖ Voltage and current range settings (page 51)
- ❖ PT and CT ratio settings (page 52)
- ❖ Nominal voltage settings (page 52)
- ❖ Measured frequency settings (page 53)
- ❖ PLL source settings (page 53)
- ❖ Voltage calculation method settings (page 54)
- ❖ Harmonic calculation method settings (page 54)
- ❖ THD calculation method settings (page 55)
- ❖ Power factor calculation method settings (page 55)
- ❖ Flicker calculation settings (page 56)
- ❖ Voltage recording method settings (page 56)
- ❖ IEC flicker filter settings (page 57)
- ❖ ΔV10 flicker measurement channel settings (page 57)
- ❖ EN50160 settings (page 58)

Connection method settings (CH 1, 2, 3)

SYSTEM

DF 2

MEASURE

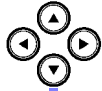

Wiring

ENTER

Select from pull-down menu

↑

↓

ENTER

Confirm

ESC

Cancel

123ch	4ch	UReference	120 V
Wiring	3P4W	Frequency	60Hz
Clamp	1mV/A 9661	PLL Source	U1
U Range	150V	U CalcType	PHASE-N

1P2W

To measure single-phase two-wire power lines

1P3W

To measure single-phase three-wire power lines

3P3W2M

To measure single-phase three-wire power lines (using the 2 power meter method)

(Use this when measuring three-phase power with 2-spot current measurement only.)

3P3W3M

To measure three-phase three-wire power lines (using the 3 power meter method)

3P4W

To measure three-phase four-wire power lines

Connection method settings (CH 4)

SYSTEM

DF 2

MEASURE

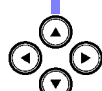

Wiring

ENTER

Select from pull-down menu

↑

↓

ENTER

Confirm

ESC

Cancel

123ch	4ch	UReference	120 V
Wiring	3P4W	Frequency	60Hz
Clamp	1mV/A 9661	PLL Source	U1
U Range	150V	U CalcType	PHASE-N

OFF

Set when you are not using channel 4.

AC

Set when measuring the voltage of neutral lines or other systems.

DC

Set when measuring DC power lines.

When set to DC, the voltage of a DC power line can be measured.

Regardless of the setting, current can be measured only in AC power lines.

Even when you set DC, the 0 order harmonic cannot be displayed.

Clamp sensor settings

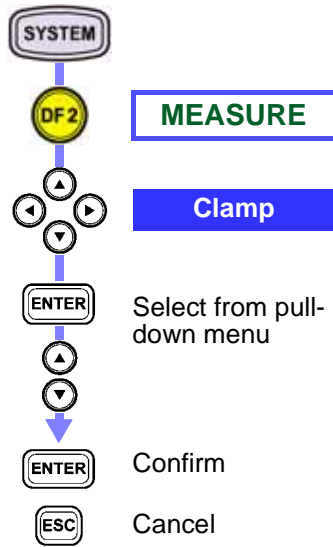

123ch	4ch	UReference	120 V
U Range	150V	Frequency	60Hz
Clamp	1mV/A 9661 1mV/A 9661	PLL Source	U1
U CalcType		U CalcType	PHASE-N
PT Ratio	1	Harm Calc	LEVEL

Set the output rate (the output voltage to input current ratio) of the clamp sensor you are using.

Settings of the optional clamp on sensor:

0.1mV/A, 1mV/A

9661 Use the 9661 CLAMP ON SENSOR

9660 Use the 9660, 9695-03 CLAMP ON SENSOR

10 mV/A 9694 Use the 9694, 9695-02 CLAMP ON SENSOR

100 mV/A Use the 9657-10, 9675 CLAMP ON LEAK SENSOR

5000A 9667 Use the 9667 FLEXIBLE CLAMP ON SENSOR (5000 A range)

500A 9667 Use the 9667 FLEXIBLE CLAMP ON SENSOR (500 A range)

1000A 9669 Use the 9669 CLAMP ON SENSOR

Voltage and current range settings

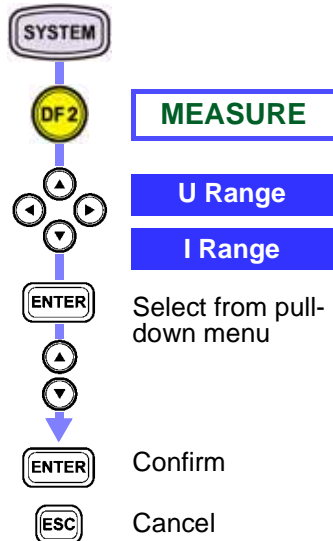

Clamp	1mV/A 9661 1mV/A 9661	PLL Source	U1
U Range	150V 150V	U CalcType	PHASE-N
PT Ratio	1	Harm Calc	LEVEL
I Range	50A 50A	THD Calc	THD_F
UI Ratio	1	PF Type	PF

Channel (Voltage range)
 123ch **150 V, 300 V, 600 V**
 4 ch (AC) **60 V, 150 V, 300 V, 600 V**
 4 ch (DC) **60 V, 600 V**

Clamp settings (Current range)
 0.1mV/A **500A, 5000A**
 1mV/A 9661 **50A, 500A**
 9660 **50A, 100A**
 10mV/A 9694 **5A, 50A**
 100mV/A **0.5A, 5A**
 5000A 9667 **500A, 5000A**
 500A 9667 **50A, 500A**
 1000A 9669 **100A, 1000A**

The range that can be selected depends on the clamp you choose.

NOTE

- The ranges of channels 1 to 3 (CH 1, 2, 3) are the same. You cannot set ranges separately for each channel.
- Set the voltage range higher than the set nominal voltage. The accuracy of this device is guaranteed for values measured within 1% to 110% of the set range.
- The 9694 is designed for 5 A. It can be used in the 50-A range, but the accuracy specification only applies to the 5-A range.

PT and CT ratio settings

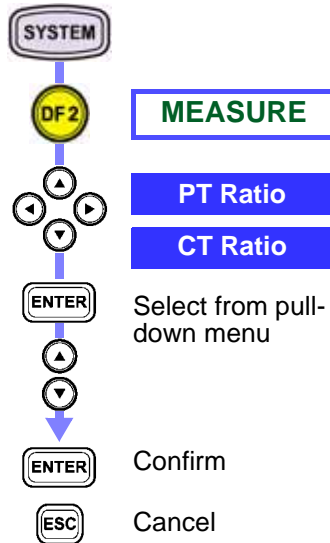

U Range	150V	150V	U CalcType	PHASE-N
PT Ratio	1	1	Harm Calc	LEVEL
I Range	50A	50A	THD Calc	THD_F
CT Ratio	1	1	PF Type	PF
			Flicker	ΔV10

V(PT) Ratio **VARIABLE, 1, 60, 100, 200, 300, 600, 700, 1000, 2000, 2500, 5000**

CT Ratio **VARIABLE, 1, 40, 60, 80, 120, 160, 200, 240, 300, 400, 600, 800, 1200**

You can set the optional PT(VT) and CT ratios within the 0.01 to 9999.99 range.

When setting Optional:

- Moving between values
: Moves up through the values : Moves down through the values
 Setting value
: Increases the value : Lowers the value

NOTE

When measuring on the secondary side of high-voltage and special high-voltage power lines, you can use this to convert the voltage and current values of the primary side.

Nominal voltage settings

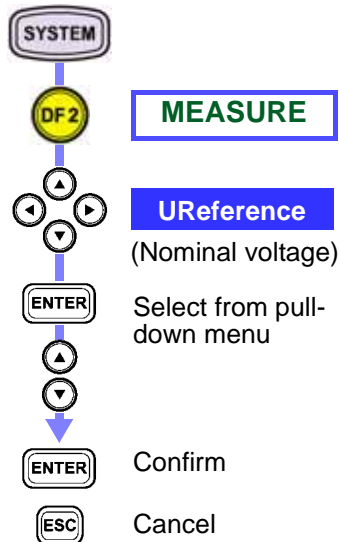

	123ch	4ch	UReference	120 V
Wiring	3P4W	AC	Frequency	60Hz
Clamp	1mV/A 9661	1mV/A 9661	PLL Source	U1
U Range	150V	150V	U CalcType	PHASE-N
PT Ratio	1	1	Harm Calc	LEVEL

100 V, 101 V, 110 V, 120 V, 200 V, 202 V, 208 V, 220 V, 230 V, 240 V, 277 V, 346 V, 380 V, 400 V, 415 V, 480 V, 600 V, VARIABLE

Nominal voltage is effective for channels 1 to 3.

You can set the optional nominal voltage within the 50 to 600 range.

When setting Optional:

- Moving between values
: Moves up through the values : Moves down through the values
 Setting value
: Increases the value : Lowers the value

NOTE

Nominal voltage settings use dip, swell, and interruption threshold settings as references and reference voltage for ΔU .

Measured frequency settings

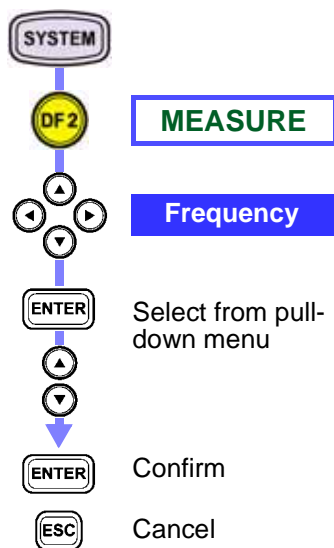

	123ch	4ch	UReference	120 V
Wiring	3P4W	AC	Frequency	60Hz
Clamp	1mV/A 9661	1mV/A 9661	PLL Source	U1
U Range	150V	150V	U CalcType	PHASE-N
PT Ratio	1	1	Harm Calc	LEVEL

50 Hz, 60 Hz, 400 Hz

Inter-harmonics, flicker and EN50160 cannot be measured at 400 Hz.

NOTE

- Set the frequency used for internal processing.
- Be sure to note that the calculation result, particularly for harmonics, will be incorrect, if the setting deviates from the nominal frequency of the measuring line.
- If set to 50 Hz, 10 waveforms are used to calculate harmonics, if set to 60 Hz, 12 waveforms are used to calculate harmonics, and , if set to 400 Hz, 80 waveforms are used to calculate harmonics.
- If the PLL unlocks due to power failure or another reason, sampling synchronous at the set frequency is internally generated for calculation.

PLL source settings

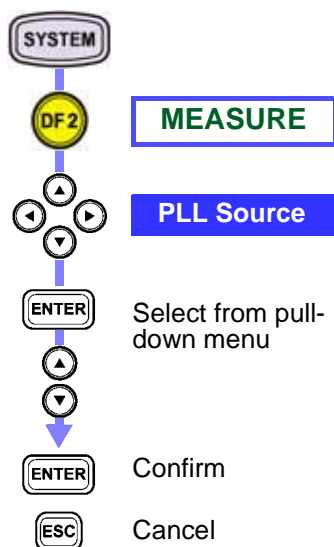

	123ch	4ch	UReference	120 V
Wiring	3P4W	AC	Frequency	60Hz
Clamp	1mV/A 9661	1mV/A 9661	PLL Source	U1
U Range	150V	150V	U CalcType	PHASE-N
PT Ratio	1	1	Harm Calc	LEVEL

U1, U2, U3

The PLL source is the source used to measure frequencies. The frequency measurement range is 42.500 Hz to 69.000 Hz.

When the 400 Hz measurement frequency is selected, the frequency measurement range is 360 to 440 Hz.

Voltage calculation method settings

SYSTEM

DF2

MEASURE

U CalcType

ENTER

Select from pull-down menu

ENTER

Confirm

ESC

Cancel

Clamp	1mV/A 9661	1mV/A 9661	PLL Source	U1
U Range	150V	150V	U CalcType	PHASE-N
PT Ratio	1	1	Harm Calc	LEVEL
I Range	50A	50A	THD Calc	THD_F
CT Ratio	1	1	PF Type	PF

PHASE-N (phase-to-neutral voltage)**LINE-LINE** (line-to-line voltage)

It is possible to switch to phase-to-neutral voltage or line-to-line voltage only when the connection method is 3P3W3M (three-phase three-wire three power meter method) or 3P4W (three-phase four-wire).

- With 3P3W3M:
Normally, line-to-line voltage (LINE-LINE) is measured, but this can be converted to phase-to-neutral voltage (PHASE-N) with internal processing on the 3196. The line-to-line voltage is processed so that the center of the triangle that created the three-phase line-to-line voltage becomes the neutral point.
- With 3P4W:
Normally, phase-to-neutral voltage (PHASE-N) is measured, but this can be converted to line-to-line voltage (LINE-LINE) with internal processing on the 3196.

Harmonic calculation method settings

SYSTEM

DF2

MEASURE

Harm Calc

(Harmonic calculation)

ENTER

Select from pull-down menu

ENTER

Confirm

ESC

Cancel

Clamp	1mV/A 9661	1mV/A 9661	PLL Source	U1
U Range	150V	150V	U CalcType	PHASE-N
PT Ratio	1	1	Harm Calc	LEVEL
I Range	50A	50A	THD Calc	THD_F
CT Ratio	1	1	PF Type	PF

LEVEL
(RMS value)

Displays the harmonic RMS voltage or the harmonic RMS current.

% of FND
(Proportions)

Displays the harmonic component of each order around the fundamental wave (the proportion of harmonic voltage or harmonic current).

THD calculation method settings

SYSTEM

DF2

MEASURE

THD Calc

(THD calculation)

ENTER

Select from pull-down menu

ENTER

Confirm

ESC

Cancel

Clamp	1mV/A 9661	1mV/A 9661	PLL Source	U1
U Range	150V	150V	U CalcType	PHASE-N
PT Ratio	1	1	Harm Calc	LEVEL
I Range	50A	50A	THD Calc	THD_F
CT Ratio	1	1	PF Type	PF

THD_F The ratio of total harmonics to fundamental wave.

THD_R The ratio of total harmonics to total harmonics, fundamental wave included.

The selected THD calculation method is valid for both harmonic voltage and harmonic current.

What is THD?

THD (Total Harmonic Distortion) indicates the total harmonic distortion factor.

Power factor calculation method settings

SYSTEM

DF2

MEASURE

PF Type

PF Type

ENTER

Select from pull-down menu

ENTER

Confirm

ESC

Cancel

Clamp	1mV/A 9661	1mV/A 9661	PLL Source	U1
U Range	150V	150V	U CalcType	PHASE-N
PT Ratio	1	1	Harm Calc	LEVEL
I Range	50A	50A	THD Calc	THD_F
CT Ratio	1	1	PF Type	PF
			Flicker	ΔV10

PF Power factor

DPF Displacement power factor

What is a power factor?

- The PF (power factor) is the active power to apparent power ratio. Since calculations include all the frequency components, the greater the harmonic current becomes, the smaller the power factor becomes.
- The DPF (displacement power factor) is the cosine of the phase difference between the fundamental wave voltage and the fundamental wave current. It is only calculated using fundamental wave components and does not include harmonic wave components.

Flicker calculation settings

SYSTEM

DF 2

MEASURE



Flicker

ENTER

Select from pull-down menu



ENTER

Confirm

ESC

Cancel

PT Ratio	1	1	Harm Calc	LEVEL
I Range	50A	50A	THD Calc	THD_F
CT Ratio	1	1	PF Type	PF
			Flicker	$\Delta V10$
			TimePlot U	Urms
			Flicker CH	U1

OFF Flicker measurement is not used.**Pst,Plt** IEC flicker is measured. **$\Delta V10$** $\Delta V10$ flicker is measured.

$\Delta V10$ flicker can only be measured on one of voltage channels U1, U2 or U3. The measurement source is the channel that is selected for flicker measurement.

Voltage recording method settings

SYSTEM

DF 2

MEASURE



TimePlot U

ENTER

Select from pull-down menu



ENTER

Confirm

ESC

Cancel

PT Ratio	1	1	Harm Calc	LEVEL
I Range	50A	50A	THD Calc	THD_F
CT Ratio	1	1	PF Type	PF
			Flicker	$\Delta V10$
			TimePlot U	Urms
			Flicker CH	U1

Urms Records the voltage rms value**S(t)** Records the flicker value instantly.
(Pst, Plt is selected for Flicker) **ΔU** Records the deviation with respect to the nominal RMS voltage.
($\Delta V10$ is selected for Flicker)

The data recorded is reflected in the voltage fluctuation time plot.

IEC flicker filter settings

SYSTEM

DF2

MEASURE



Filter

ENTER

Select from pull-down menu



ENTER

Confirm



Cancel

I Range	50A	50A	THD Calc	THD_F
CT Ratio	1	1	PF Type	PF
			Flicker	Pst, Plt
			TimePlot U	S(+)
			Filter	230V lamp

100 V lamp, 120 V lamp, 230 V lamp

Select a lamp system filter defined in IEC 61000-4-15. This setting is available only when "Pst, Plt" is selected for Flicker.

 Δ V10 flicker measurement channel settings

SYSTEM

DF2

MEASURE

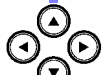

Flicker CH

ENTER

Select from pull-down menu



ENTER

Confirm



Cancel

I Range	50A	50A	THD Calc	THD_F
CT Ratio	1	1	PF Type	PF
			Flicker	Δ V10
			TimePlot U	Urms
			Flicker CH	U1
			EN50160	OFF

U1, U2, U3

Δ V10 flicker can only be measured on one of channels U1, U2 or U3.

This setting is available only when Δ V10 is selected for Flicker.

EN50160 settings

SYSTEM

DF2

MEASURE

EN50160

ENTER

Select from pull-down menu

↑

↓

ENTER

Confirm

ESC

Cancel

CT Ratio	1	1	PF Type	PF
			Flicker	ΔV10
			TimePlot U	Urms
			Flicker CH	U1
			EN50160	OFF

ON

Perform evaluations conforming to the EN50160.

OFF

Do not perform evaluations conforming to the EN50160.

The EN50160 (Voltage characteristics of electricity supplied by public distribution systems) is a voltage-quality evaluation method used in Europe. It supports evaluations of 230-V 50-Hz power systems only.

For detailed information on the EN50160, see the Instruction Manual for EN50160.

4.3.2 Recording Settings

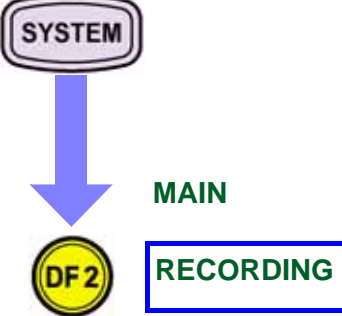

SYSTEM

↓ MAIN

DF 2

RECORDING

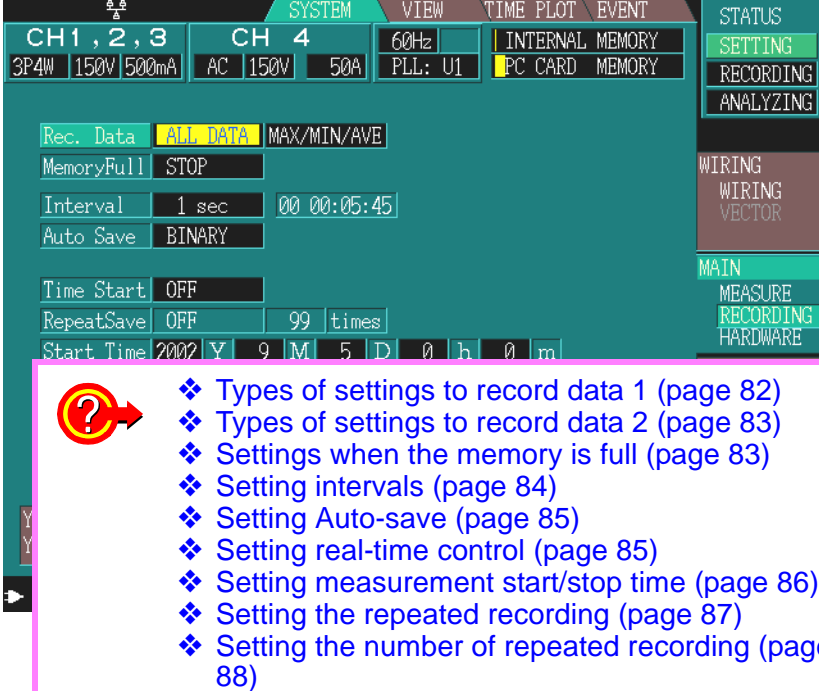

- ❖ Types of settings to record data 1 (page 82)
- ❖ Types of settings to record data 2 (page 83)
- ❖ Settings when the memory is full (page 83)
- ❖ Setting intervals (page 84)
- ❖ Setting Auto-save (page 85)
- ❖ Setting real-time control (page 85)
- ❖ Setting measurement start/stop time (page 86)
- ❖ Setting the repeated recording (page 87)
- ❖ Setting the number of repeated recording (page 88)

For details, see 6.2 "Time Plot Settings" (page 81).

4.3.3 Hardware Settings

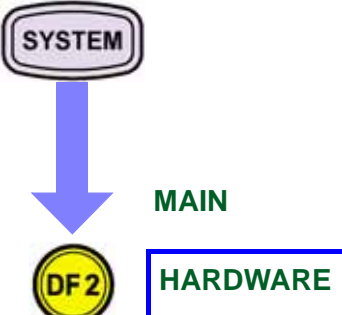

SYSTEM

↓ MAIN

DF 2

HARDWARE

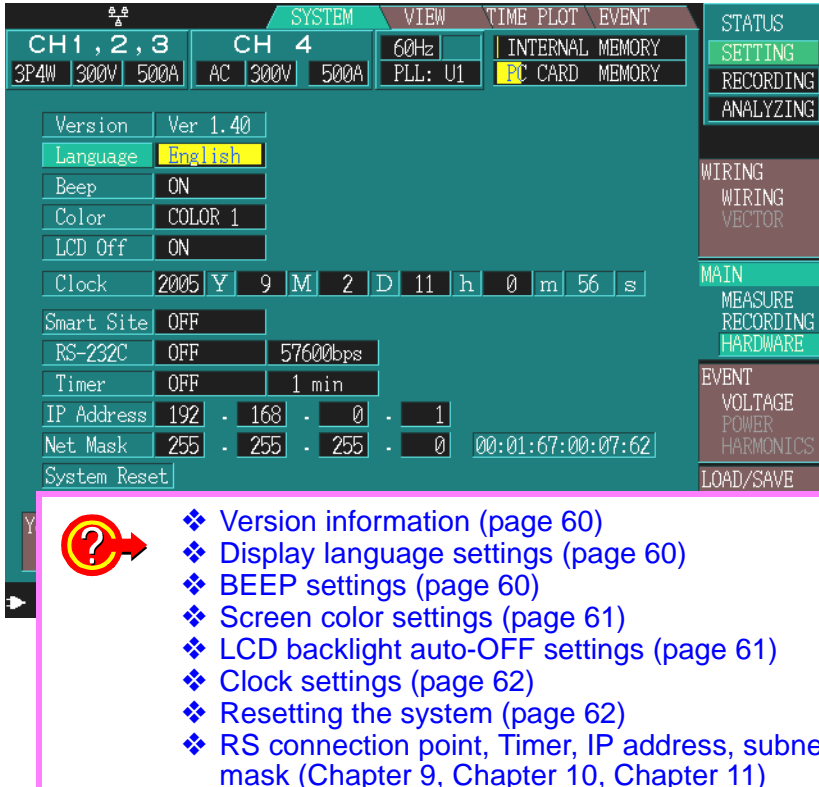

- ❖ Version information (page 60)
- ❖ Display language settings (page 60)
- ❖ BEEP settings (page 60)
- ❖ Screen color settings (page 61)
- ❖ LCD backlight auto-OFF settings (page 61)
- ❖ Clock settings (page 62)
- ❖ Resetting the system (page 62)
- ❖ RS connection point, Timer, IP address, subnet mask (Chapter 9, Chapter 10, Chapter 11)

Version information

SYSTEM

DF 2

HARDWARE

Version

Version	Ver 1.40
Language	English
Beep	ON

Indicates the version of this device.

Display language settings

SYSTEM

DF 2

HARDWARE

Language

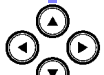

ENTER

Select from pull-down menu



ENTER

Confirm

ESC

Cancel

Version	Ver 1.40
Language	English
Beep	ON
Color	COLOR 1
LCD Off	ON

English, Japanese, Deutsch, Francais, Italiano, Espanol, Chinese (Simplified)

BEEP settings

SYSTEM

DF 2

HARDWARE

Beep



ENTER

Select from pull-down menu



ENTER

Confirm

ESC

Cancel

Version	Ver 1.40
Language	English
Beep	ON
Color	COLOR 1
LCD Off	ON

OFF, ON

Screen color settings

SYSTEM

DF2

HARDWARE

Color

Color

(Screen color)

ENTER

Select from pull-down menu

ENTER

Confirm

ESC

Cancel

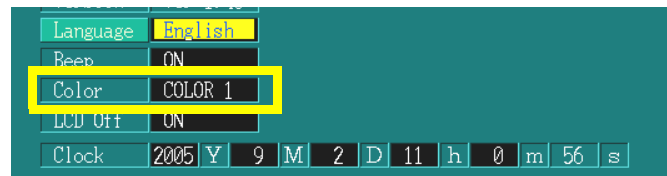

- COLOR 1** Default
- COLOR 2** Dark blue
- COLOR 3** Monochrome (characters are white)
- COLOR 4** Light blue
- MONO** Monochrome (characters are black)

LCD backlight auto-OFF settings

SYSTEM

DF2

HARDWARE

LCD Off

LCD Off

(LCD backlight)

ENTER

Select from pull-down menu

ENTER

Confirm

ESC

Cancel

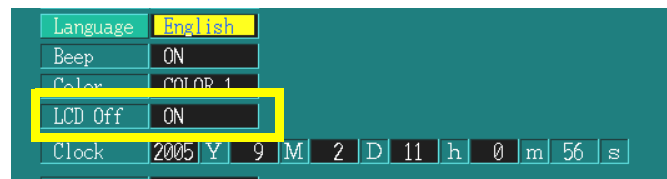

- ON** Ordinarily turns on the LCD backlight.
- 1 min, 5 min, 10 min, 30 min, 1 hour** Automatically turns off the backlight after the set time.

How do I turn the backlight on again?

If the backlight turns off automatically, press any key on the device to turn the backlight on again.

You can turn the backlight on again even when in KEYLOCK status.

NOTE

This helps to reduce the device's power consumption when using a battery pack without the AC adapter.

Clock settings

SYSTEM

DF 2

HARDWARE

Clock

ENTER



Numeric value settings



ENTER

Confirm

ESC

Cancel

Language	English
Beep	ON
Color	COLOR 1
LCD Off	ON
Clock	2005 Y 9 M 2 D 11 h 0 m 56 s
Smart Site	OFF

  Changes columns in the following order: year (Y), month (M), day (D), hour (h), and minutes (m).

NOTE

Make sure that you enter "00" in the seconds column. Press  the instant the seconds are 00.

Resetting the system

SYSTEM

DF 2

HARDWARE

System Reset

ENTER

ENTER

Smart Site	OFF	
RS-232C	OFF	57600bps
Timer	OFF	1 min
IP Address	192	· 168 · 0 · 1
Net Mask	255	· 255 · 255 · 0 00:01:67:00:07:62
System Reset		

NOTE

When you think that the device is not operating properly, you can reset the system. If you reset the system, display settings (except language, LAN, and clock settings) return to their defaults.

4.4 Event Settings Screen

4.4.1 Measurement Settings

SYSTEM

↓

EVENT

↓

DF 3

↓

VOLTAGE

↓

DF 3

↓

POWER

↓

DF 3

↓

HARMONICS

VOLTAGE

- ❖ Automatic setting of event thresholds (page 123)
- ❖ Turning off all event thresholds (page 123)
- ❖ Setting the event recording sequence (page 124)
- ❖ Event ON/OFF settings (page 124)
- ❖ Setting of event thresholds (page 125)
- ❖ Setting of event thresholds (voltage waveform comparison) (page 125)

POWER

- ❖ Event ON/OFF settings and threshold settings (page 126)

For details, see 7.3 "Event Settings" (page 121).

4.5 Load/Save Screen

The diagram illustrates the navigation path from the SYSTEM menu to the DF4 (MEMORY) screen, and then to the DF4 (PC-CARD) screen. A blue arrow points from the SYSTEM menu to the DF4 (MEMORY) screen, and another blue arrow points from the DF4 (MEMORY) screen to the DF4 (PC-CARD) screen.

LOAD/SAVE

MEMORY

PC-CARD

The top screenshot shows the SYSTEM menu with the following data:

CH 1, 2, 3	CH 4	VIEW	TIME PLOT	EVENT	STATUS
3P4W 150V 50A	AC 150V 50A	60Hz	INTERNAL MEMORY		SETTING
		PLL: U1	CARD MEMORY		RECORDING
					ANALYZING

The table below shows the list of data files:

No.	Date	Time	Name
1	06-24	11:47:09	TEST
2	06-24	11:47:25	A_LINE
3	06-24	11:47:51	B_LINE
4	06-24	11:48:08	C_LINE
5	06-24	11:55:45	AC_LOADS
6	06-24	11:51:50	TURBINE
7	06-24	11:52:06	UPS
8	06-24	11:53:25	CONTROL
9	06-24	11:54:21	
10	06-24	11:58:43	

The bottom screenshot shows the SYSTEM menu with the following data:

CH 1, 2, 3	CH 4	VIEW	TIME PLOT	EVENT	STATUS
3P4W 300V 50A	AC 300V 50A	50Hz	INTERNAL MEMORY		SETTING
		PLL: U1	PC CARD MEMORY		RECORDING
					ANALYZING

The table below shows the list of files on the PC card:

No.	File Name	Size	Date
1	B1110901	<DIR>	01-11-09 12:04
2	T1110902	<DIR>	01-11-09 12:04
3	H3196006	BMP	41742 01-11-09 12:03
4	TBST	SET	3904 01-11-09 12:03
5	TEXTWAVE	<DIR>	01-11-09 12:03

9.1 "Using the Internal Memory" (page 142)

9.2 "Using a PC Card" (page 143)

For details, see Chapter 9 "Loading and Saving Settings and Measured Data" (page 141).

Using Waveforms, Vectors, DMMs, and Bar Graphs

(VIEW Screen)

Chapter 5

1. Check measurement data on the waveform display.
 - ❖ Waveform Display (page 67)
2. Check measurement data on the vector display.
 - ❖ Vector Display (page 70)
3. Check measurement data on the DMM display.
 - ❖ DMM Display (page 73)
4. Check measurement data with harmonics.
 - ❖ Harmonics Bar Graph (page 74)
 - ❖ Harmonics List Screen (page 76)
5. Check event data on the VIEW display.
 - ❖ Analyzing Event Occurrences (page 130)
 - ❖ Analyzing Transient Waveforms (page 131)

5.1 Using the VIEW Screen

Switching screen display

You can confirm such items as waveform data and the measurement status on the VIEW screen.

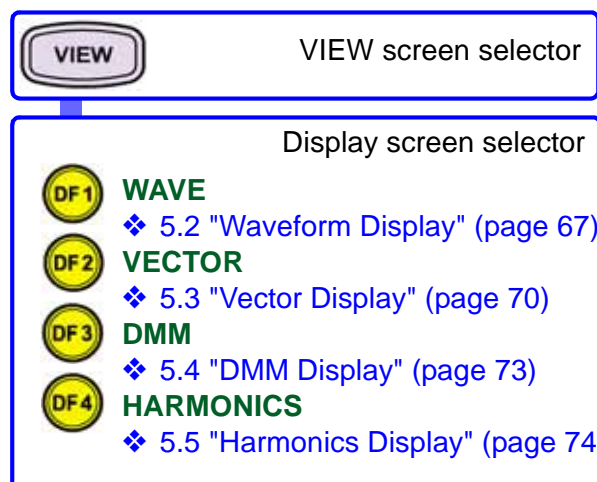

The VIEW screen is composed of a number of screens corresponding to the **DF1** to **DF4** (DF: display function) keys.

When you press a DF key, the screen corresponding to that key appears.

Each time you press the same DF key, the display changes.

About screen configuration

- ❖ 2.2.2 "Screen Configurations"(page 17)
- ❖ 2.2.3 "Screen Details"(page 24 to 27)

Screen operations depending on the internal operation status

The screens that can be displayed differ depending on the internal operation status.

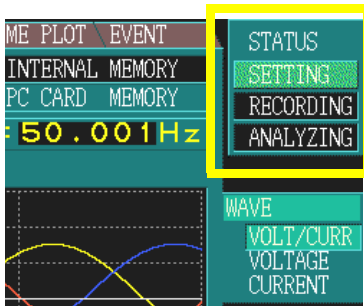

Internal operation status	Display	Display update
[SETTING]	Contents of the display update during setting.	Approximately 1 second
[RECORDING]	Contents of the latest display update during measurement.	
[ANALYZING]	Contents of the display update during analysis, or contents at the moment an event selected in TIME PLOT or EVENT occurs.	

Screen display during [SETTING] or [RECORDING]:

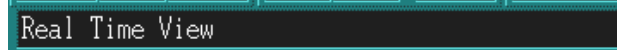

Indicates the screen being displayed for the current measurement.

Screen display during [ANALYZING]:

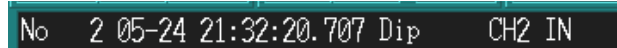

Indicates the analysis screen being displayed for the selected event.

? What is the relationship between the operation status and key operations?

? The key does not start recording during [ANALYZING] operation!

? Changing settings while [RECORDING] or [ANALYZING] is displayed?

During [RECORDING] operation: → → [SETTING]

During [ANALYZING] operation: → [SETTING]

In either case, data stored in internal memory is erased.

CAUTION! Pressing erases all data stored in internal memory.

Return to the setting mode from analysis: → → [RECORDING]

Start recording: → [RECORDING]

5.2 Waveform Display

Example: 4-channel waveform with a 3P4W (three-phase four-wire) configuration

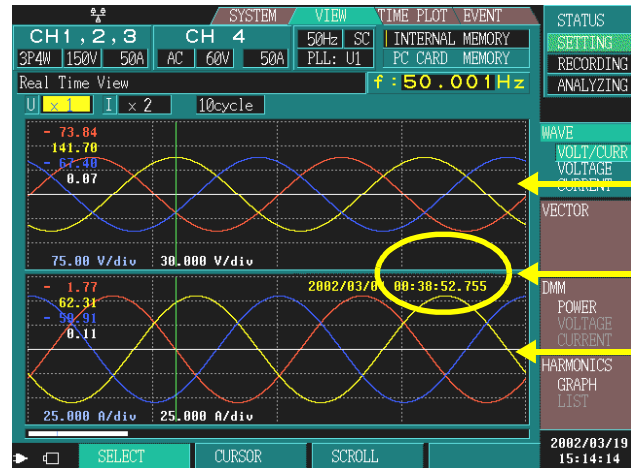
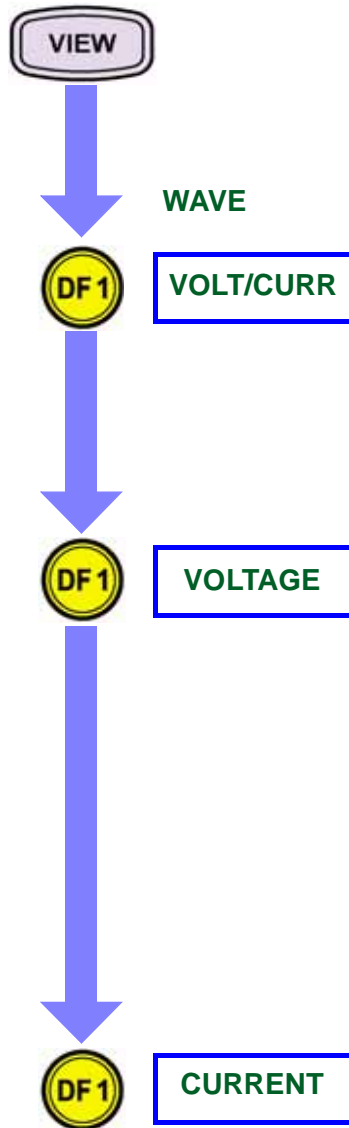

Superimposes and displays 4 channels of the voltage waveform.

Cursor value (time)

Superimposes and displays 4 channels of the current waveform.

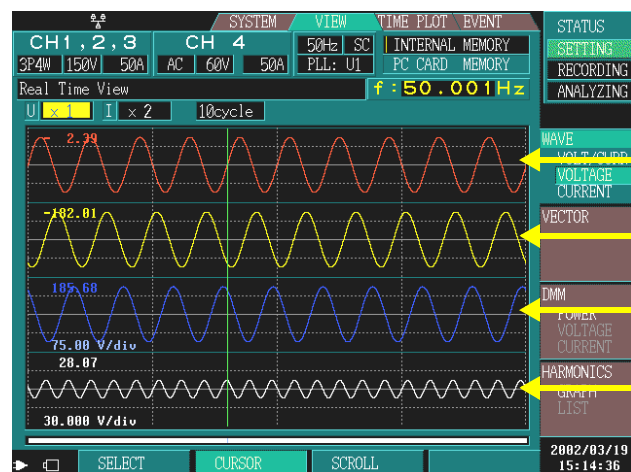

Voltage waveform
Red: CH1

Yellow: CH2

Blue: CH3

White: CH4

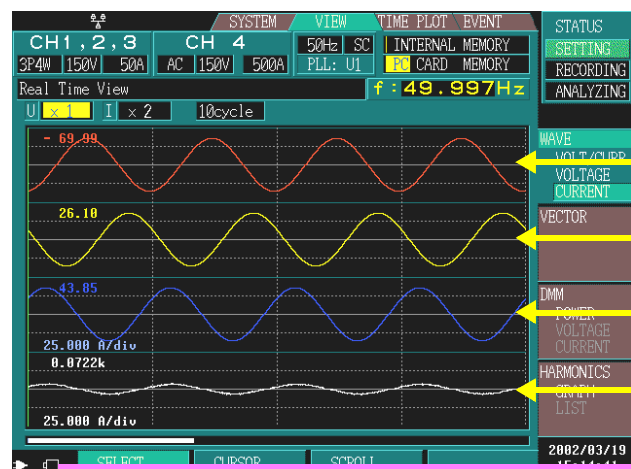

Current waveform
Red: CH1

Yellow: CH2

Blue: CH3

White: CH4

- ❖ Enlarging waveforms (page 68)
- ❖ Changing the Y-axis scale of waveforms (page 68)
- ❖ Changing the X-axis scale of waveforms (page 68)
- ❖ Reading the cursor value (cursor measurement) [VOLTAGE], [CURRENT] (page 69)
- ❖ Scrolling through waveforms (page 69)

Enlarging waveforms Changing the Y-axis scale of waveforms

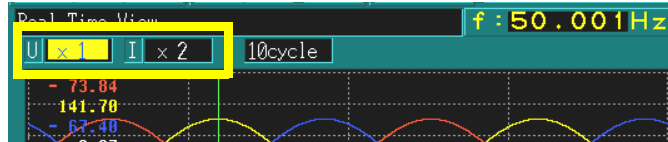
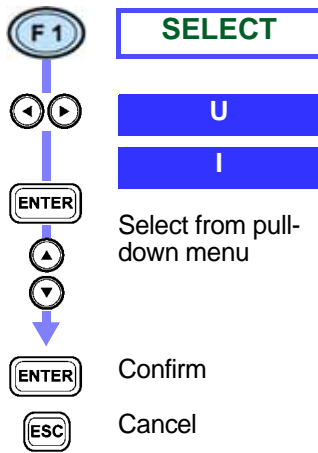

x1/3, x1/2, x1, x2, x5, x10

When you want to reduce the waveform, make the scale smaller.
When you want to enlarge the waveform, make the scale larger.

Changing the X-axis scale of waveforms

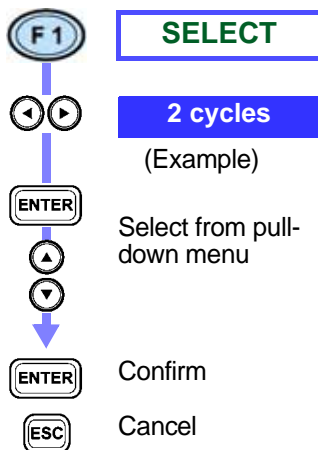

For 50 Hz **2 cycles, 4 cycles, 10 cycles**
For 60 Hz **2 cycles, 4 cycles, 10 cycles, 12 cycles**
For 400 Hz **16 cycles, 32 cycles, 80 cycles**

The waveforms are displayed over the entire screen in the

Reading the cursor value (cursor measurement) [VOLT/CURR]

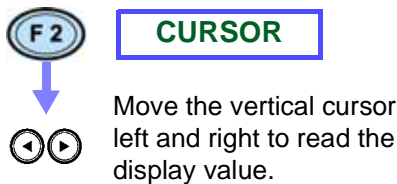

Cursor position



The cursor on the scroll bar indicates where the cursor is positioned on the saved waveform.

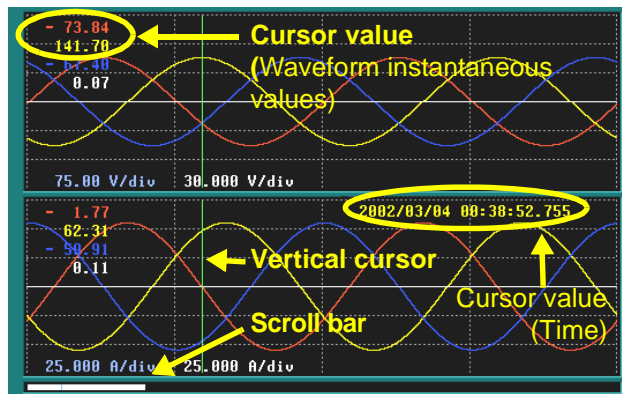

You can read waveform instantaneous values and time with the cursor.

Normally, the cursor is located at the beginning of the waveform.

Reading the cursor value (cursor measurement) [VOLTAGE], [CURRENT]

F 2

CURSOR



Move the vertical cursor left and right to read the display value.

Cursor position



The cursor on the scroll bar indicates where the cursor is positioned on the saved waveform.

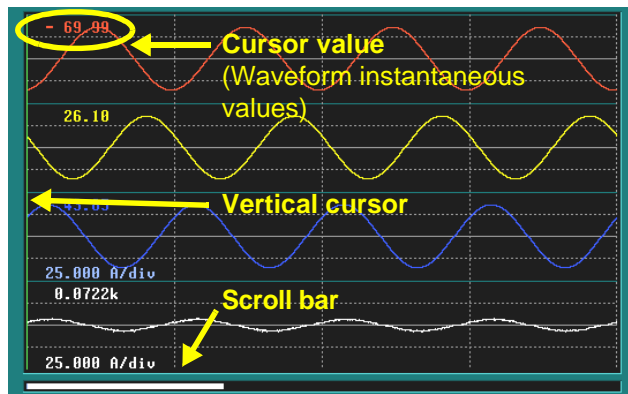

You can read waveform instantaneous values with the cursor.

Normally, the cursor is located at the beginning of the waveform.

Scrolling through waveforms

F 3

SCROLL

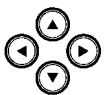

Scroll through the waveform

Normally, displays the beginning of saved waveforms (50 Hz: 10 waveforms, 60 Hz: 12 waveforms, 400 Hz: 80 waveforms).

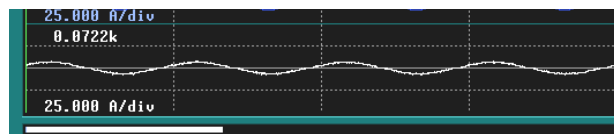

Scroll bar

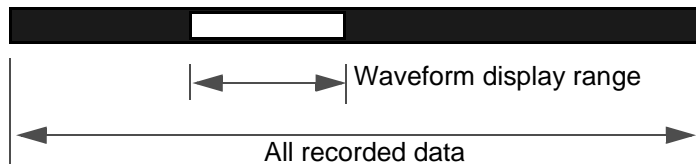

The waveform display range (white belt) on the scroll bar indicates what interval of recorded data is displayed on the screen.

When you scroll horizontally, you can check all the saved waveform.

When you scroll vertically, you can change the offset position of the displayed waveform.

NOTE

If you select an event and display a waveform, you can scroll horizontally to analyze 14 waveforms at 50 Hz, 16 waveforms at 60 Hz, or 112 waveforms at 400 Hz.

5.3 Vector Display

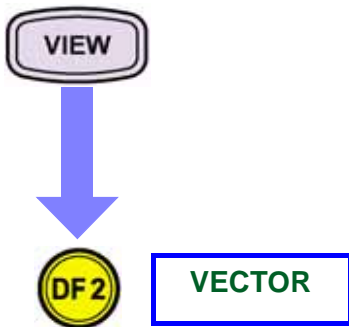

Example: 3P4W (three-phase four-wire)

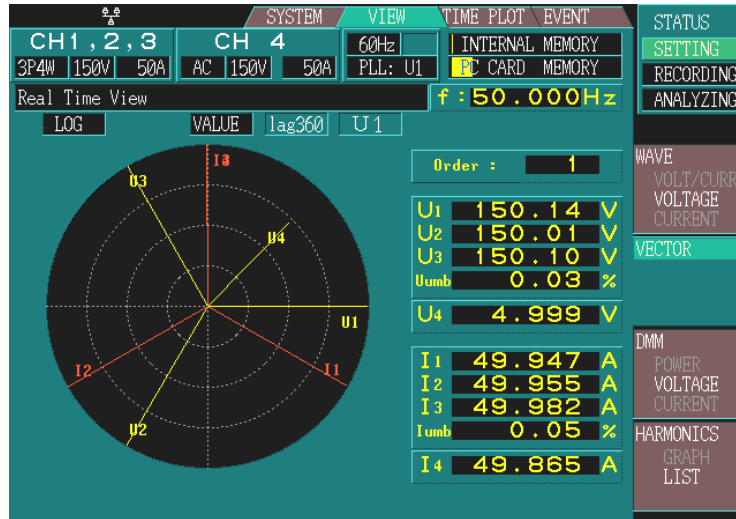

- ❖ Changing the axis display (page 70)
- ❖ Changing the RMS value/phase angle display (page 71)
- ❖ Changing the phase angle display method (page 71)
- ❖ Changing the phase angle reference source (page 71)
- ❖ Changing harmonic number of orders (page 72)

Changing the axis display

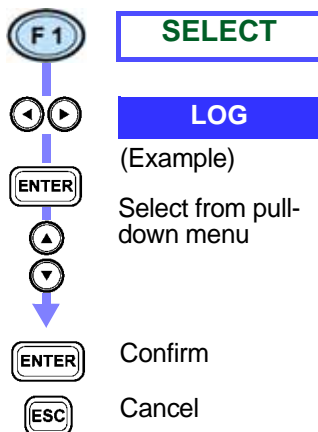

LINEAR (linear display)
LOG (logarithmic display)

You can select whether to use a linear display (LINEAR) or logarithmic display (LOG) for the vector axis.

If you select the logarithmic display method, the vector is easy to see even at low levels.

NOTE

When the 400 Hz measurement frequency is selected, harmonic analysis is performed up to the 10th order, and inter-harmonic analysis is not available.

Changing the RMS value/phase angle display

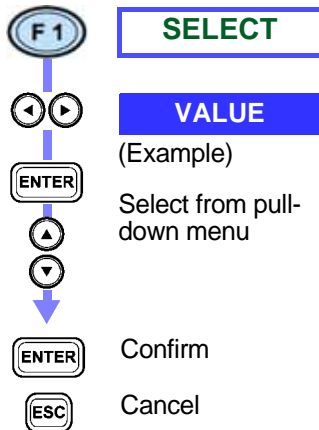

VALUE (RMS value)
PHASE (phase angle)

You can select what value to display (RMS value display or phase angle display).
When **PHASE** is selected, see "Changing the phase angle display method" (page 71).

Changing the phase angle display method

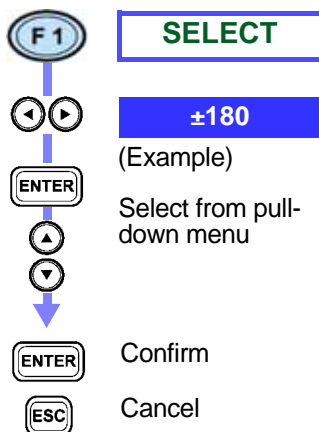

±180 (lead: 0 to 180°, lag: 0 to -180°)
lag360 (lag 0 to 360°)

You can select the type of phase angle display.
By selecting **lag360**, you can display 0 to 360°.
When **lag360** is selected, see "Changing the phase angle reference source" (page 71).

The selection affects only numerical results, and vector display remains unchanged.

Changing the phase angle reference source

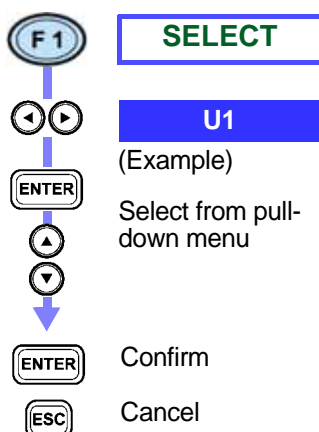

U1, I1, U2, I2, U3, I3

You can select the reference source (0°) to display the phase angle value
The selection affects only numerical results, and vector display remains unchanged.

Changing harmonic number of orders

F2

ORDER



Change the number of orders



You can select what value to display.

When you change the number of orders, the values change along with the vector.

In this case, the voltage and current unbalance factors remain the same as the values calculated using the fundamental wave (1st order).

5.4 DMM Display

Example: 3P4W (three-phase four-wire) 4-channel DMM display



POWER



VOLTAGE



CURRENT

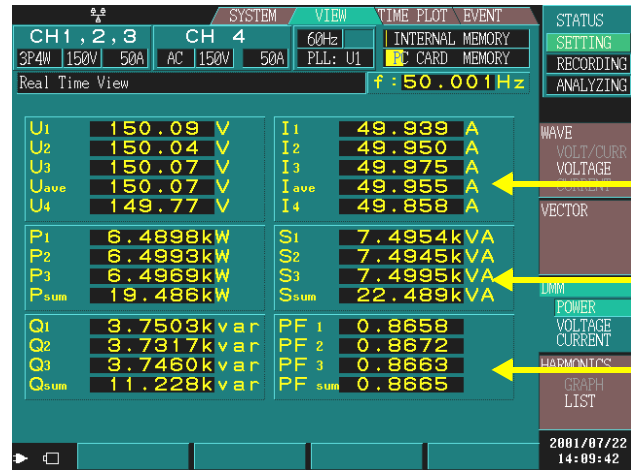

Voltage, current

Active power, apparent power

Reactive power, power factor (displacement power factor)

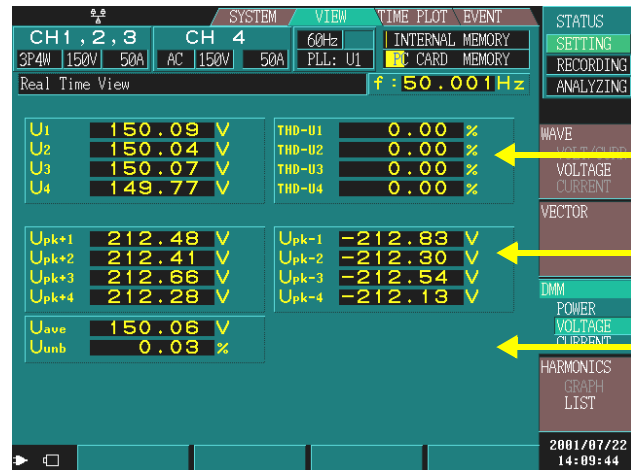

Voltage, total voltage distortion

Voltage waveform peak monitor value (+, -)

Voltage average value, Voltage unbalance factor

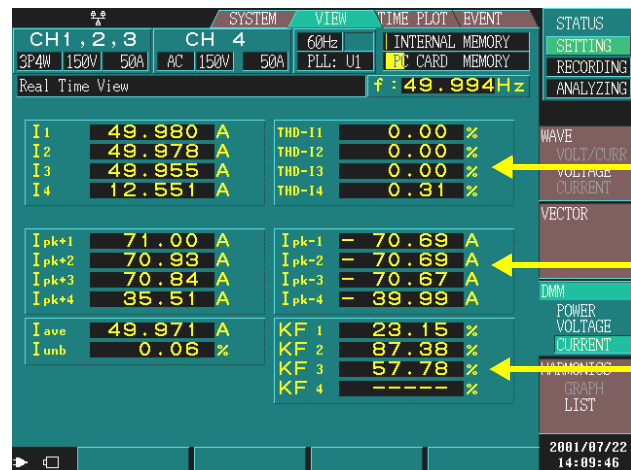

Current, total current total distortion factor

Current waveform-peak monitor value (+, -)

Current average value, K factor, and current unbalance factor



- ❖ Voltage calculation method settings (page 54)
- ❖ THD calculation method settings (page 55)
- ❖ Power factor calculation method settings (page 55)

5.5 Harmonics Display

5.5.1 Harmonics Bar Graph

VIEW



HARMONICS

GRAPH

Example: 3P4W (three-phase four-wire)

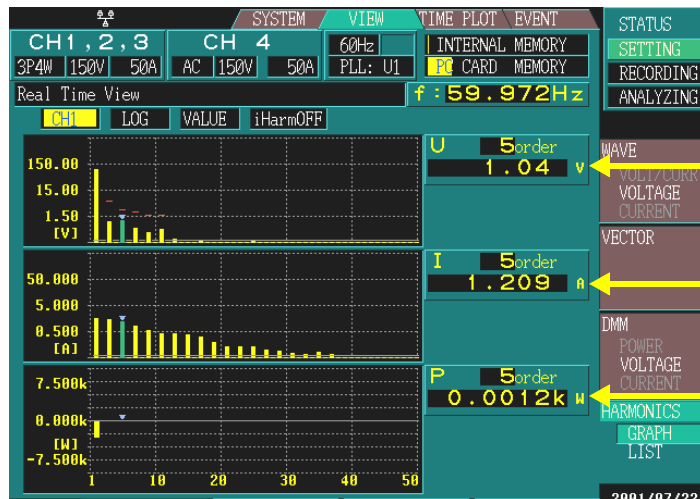

For the selected channel:
 Harmonic voltage
 Harmonic current
 Harmonic power



- ❖ Changing the display channel (page 74)
- ❖ Changing the axis display (page 75)
- ❖ Changing the RMS value/phase angle display (page 75)
- ❖ Displaying inter-harmonics (page 75)
- ❖ Changing the order number displayed (page 76)

Changing the display channel

F1

SELECT



CH1

(Example)

ENTER

Select from pull-down menu



ENTER

Confirm

ESC

Cancel

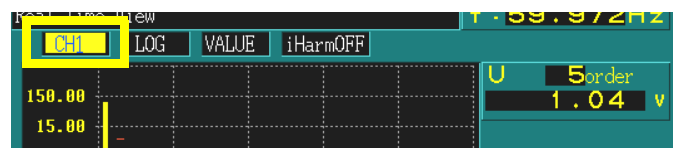

CH1, CH2, CH3, CH4

NOTE

When the 400 Hz measurement frequency is selected, harmonic analysis is performed up to the 10th order, and inter-harmonic analysis is not available.

Changing the axis display

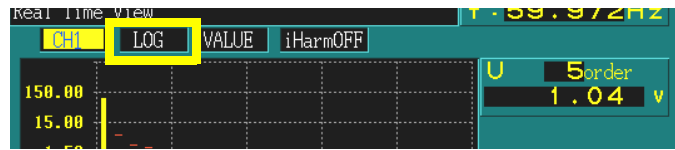
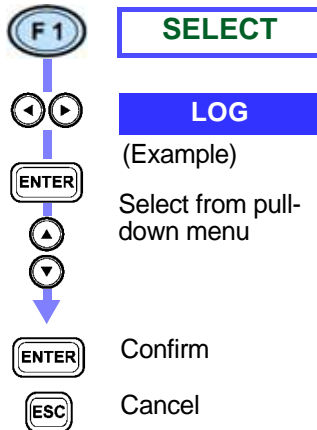

LINEAR (linear display)
LOG (logarithmic display)

When you select the logarithmic display, the vector is easy to see even at low levels.

Changing the RMS value/phase angle display

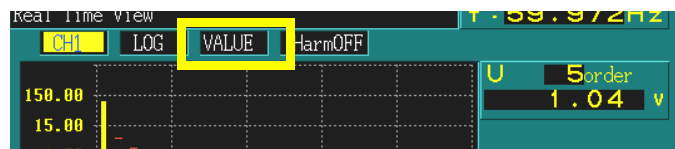
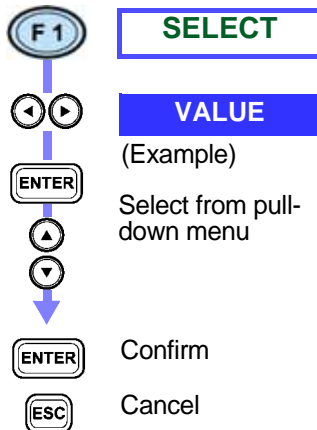

VALUE (RMS value)
PHASE (phase angle)

You can select whether RMS values or phase angles are displayed in the harmonic bar graph. The harmonic power phase angle indicates the harmonic voltage-current phase difference.

Displaying inter-harmonics

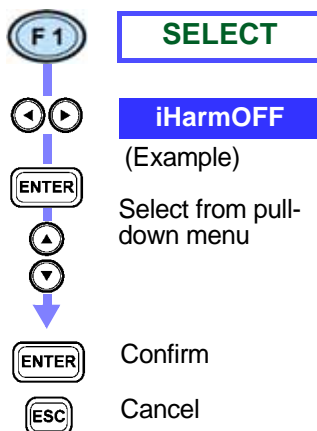

iHarmOFF, iHarmON

If you display inter-harmonics (iHarmON), the screen changes as follows.

Turquoise: inter-harmonics components

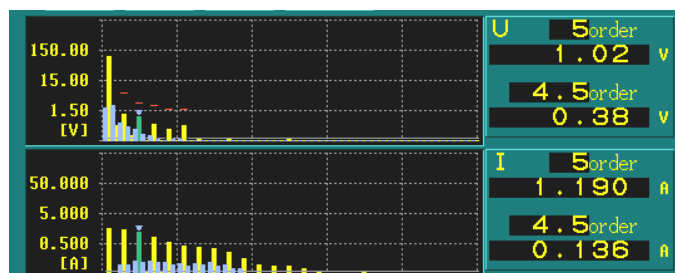

Changing the order number displayed



ORDER



Change the order number

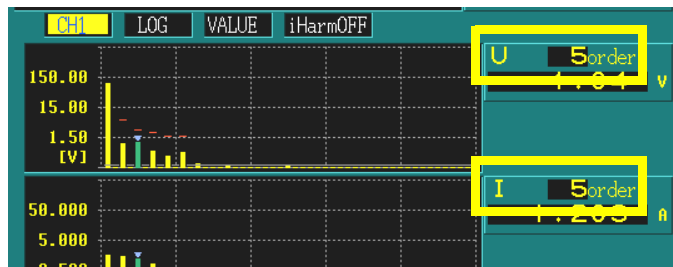

The selected order number becomes green on the bar graph. If you change the order number, the values change along with the bar graph.

5.5.2 Harmonics List Screen



HARMONICS



LIST

Example: 3P4W (three-phase four-wire)

CH1	U	VALUE	iHarmOFF
1:	96.55	2:	0.02
3:	0.95	19:	0.09
4:	0.00	20:	0.00
5:	1.00	21:	0.03
6:	0.01	22:	0.00
7:	0.54	23:	0.09
8:	0.01	24:	0.01
9:	0.38	25:	0.18
10:	0.01	26:	0.00
11:	0.52	27:	0.10
12:	0.00	28:	0.00
13:	0.18	29:	0.16
14:	0.00	30:	0.01
15:	0.17	31:	0.16
16:	0.01	32:	0.00
17:	0.20	33:	0.09
18:	0.00	34:	0.02



- ❖ Changing the display channel (page 77)
- ❖ Changing the display item (page 77)
- ❖ Changing the RMS value/phase angle display (page 77)
- ❖ Displaying inter-harmonics (page 78)

The 1st to 50th harmonic orders and 0.5 to 49.5 inter-harmonic orders are displayed in a list for the selected item.

NOTE

When the 400 Hz measurement frequency is selected, harmonic analysis is performed up to the 10th order, and inter-harmonic analysis is not available.

Changing the display channel

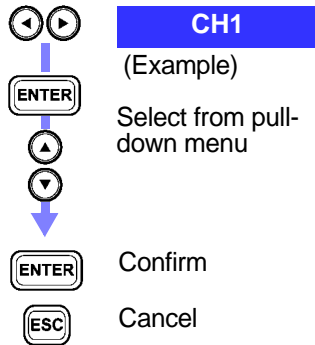

CH1	U	VALUE	iHarmOFF
1:	96.55	2:	0.02 THD 1.75
3:	0.95	19:	0.09 35: 0.12
4:	0.00	20:	0.00 36: 0.01
5:	1.00	21:	0.03 37: 0.06

CH1, CH2, CH3, CH4

Changing the display item

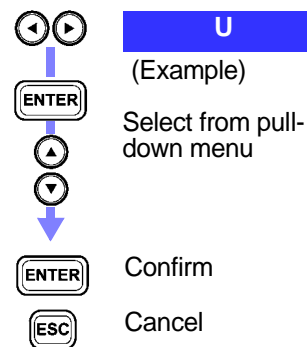

CH1	U	VALUE	iHarmOFF
1:	96.55	2:	0.02 THD 1.75
3:	0.95	19:	0.09 35: 0.12
4:	0.00	20:	0.00 36: 0.01
5:	1.00	21:	0.03 37: 0.06

U, I, P

Changing the RMS value/phase angle display

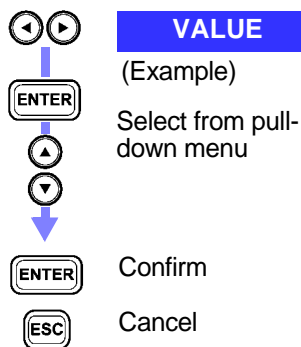

CH1	U	VALUE	iHarmOFF
1:	96.55	2:	0.02 THD 1.75
3:	0.95	19:	0.09 35: 0.12
4:	0.00	20:	0.00 36: 0.01
5:	1.00	21:	0.03 37: 0.06

VALUE (RMS value)

PHASE (phase angle)

You can select whether RMS values or phase angles are displayed in the harmonic list.

The harmonic power phase angle indicates the harmonic voltage-current phase difference.

Displaying inter-harmonics



iHarmOFF

(Example)



Select from pull-down menu



Confirm



Cancel

CH1	U	VALUE	iHarmOFF	THD
1:	96.55	2:	0.02	1.75
3:	0.95	19:	0.09	0.12
4:	0.00	20:	0.00	0.01
5:	1.00	21:	0.03	0.06

iHarmOFF, iHarmON

When active power (P) is selected as the display item, inter-harmonics are not displayed.

If you display inter-harmonics (iHarmON), the screen changes as follows.

CH1	U	VALUE	iHarmON	THD		
1:	96.93	0.23	2:	0.05 0.27	1.79 0.39	
3:	0.98	0.05	19:	0.08 0.01	35:	0.09 0.02
4:	0.02	0.05	20:	0.00 0.01	36:	0.01 0.02
5:	1.06	0.04	21:	0.02 0.01	37:	0.05 0.01
6:	0.02	0.03	22:	0.00 0.01	38:	0.00 0.02
7:	0.56	0.02	23:	0.07 0.01	39:	0.03 0.01
8:	0.01	0.01	24:	0.00 0.01	40:	0.00 0.00
9:	0.36	0.02	25:	0.18 0.00	41:	0.01 0.00
10:	0.00	0.02	26:	0.01 0.02	42:	0.00 0.01
11:	0.52	0.02	27:	0.09 0.02	43:	0.01 0.00
12:	0.00	0.02	28:	0.00 0.01	44:	0.00 0.00

The left side of the example shows harmonics and the right inter-harmonics.

Inter-harmonics order numbers are 0.5 less than the order numbers of harmonics in the same line.

(Example)

The order of inter-harmonics on the right of the 21st harmonic is 20.5.

Using the Time Series Graph

(TIME PLOT Screen) *Chapter 6*

1. Make time series settings

- ❖ Time Plot Settings (page 81)

2. Perform measurements

Press  to record data.

3. Analyze time series data

- ❖ Changes in RMS Value (page 89)
- ❖ Changes in Voltage (page 93)
- ❖ Changes in Harmonics (page 100)
- ❖ Flicker (page 104)

6.1 Using the TIME PLOT Screen

Switching screen display

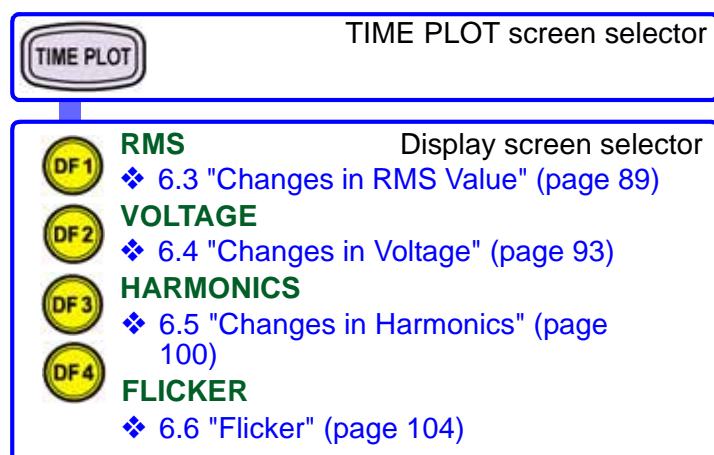

About screen configuration

- ❖ 2.2.2 "Screen Configurations"(page 18)
- ❖ 2.2.3 "Screen Details"(page 28 to 32)

The TIME PLOT screen is composed of a number of screens that correspond to the **DF1** to **DF4** (DF: display function) keys.

When you press a DF key, the screen corresponding to that key appears. Each time you press the same DF key, the display changes.

6.1 Using the TIME PLOT Screen

Screen operations depending on the internal operation status

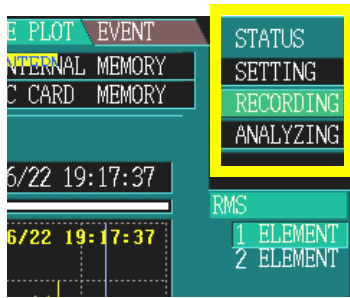

When measurement starts, the time series graph is displayed on the TIME PLOT screen.

The Y-axis and X-axis are automatically scaled so that all the time series graphs are displayed on the screen.

To change the scale of the Y-axis or X-axis, end measurement.

When measurement stops, the time series graph is no longer displayed.

Status	Display	Display update
[SETTING]	No time series graph display data.	-----
[RECORDING]	The time series graph display is updated.	At each set interval
[ANALYZING]	The time series graph display is stopped.	-----

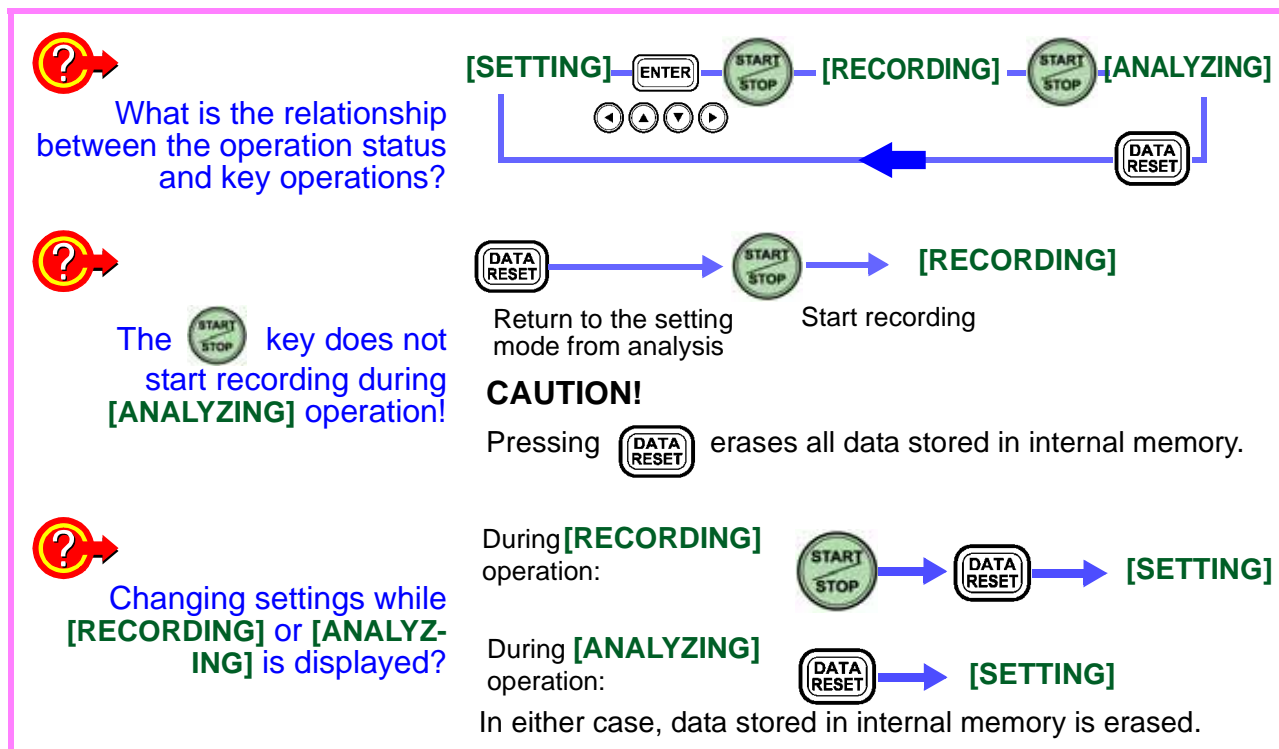

Memory status display



INTERNAL MEMORY: Internal memory
PC CARD MEMORY: ATA flash card

TIME PLOT related data capacity
 Measurement stops when memory becomes full.
 (Selectable Stop/Continuous)



Up to 100 EVENT data sets can be stored
 After 100 events are stored, the earliest are overwritten.

6.2 Time Plot Settings

To display the time series graph, make the following settings in the SYSTEM screen.



MAIN



RECORDING



- ❖ Types of settings to record data 1 (page 82)
- ❖ Types of settings to record data 2 (page 83)
- ❖ Settings when the memory is full (page 83)
- ❖ Setting intervals (page 84)
- ❖ Setting Auto-save (page 85)
- ❖ Setting real-time control (page 85)
- ❖ Setting measurement start/stop time (page 86)
- ❖ Setting the repeated recording (page 87)
- ❖ Setting the number of repeated recording (page 88)

Time series graph for TIME PLOT-DF1[RMS], TIME PLOT-DF3[HARMONICS]:

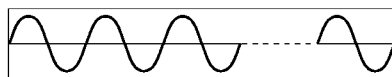

50 Hz:10 waveforms, 60 Hz:12 waveforms,
400 Hz: 80 waveforms



RMS calculation
Harmonic calculation

You can display all recorded RMS values with voltage (calculated for a single half cycle-shifted waveform) and flicker excluded.

These RMS values are based on calculations that are performed every 200 ms.

Based on these values, you can record the MAX, MIN, and AVE within the interval period, or the AVE by itself.

Example:

When the interval is set to 1 sec, 5 calculations are performed in the 1-second interval. From these, the MAX, MIN, and AVE or the AVE by itself are recorded.

Time series graph for TIME PLOT-DF2[VOLTAGE]:

At 50 Hz or 60 Hz measurement

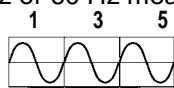

1 2 3 4 5

Voltage RMS calculation

At 400 Hz measurement

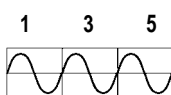

1 2 3

Voltage RMS calculation

You can display recorded voltage (value calculated for one waveform shifted over half a wave).

When measuring at 50 Hz or 60 Hz, since this voltage is calculated for each single half cycle-shifted waveform, it contains a calculated value for every half cycle.

When measuring at 400 Hz, this voltage value is calculated from a full cycle.

Based on these values, you can record the MAX and MIN within the interval period.

Example:

When the interval is set to 1 sec, 100 calculations are performed in the 1-second interval for 50 Hz current. Of these, only the MAX and MIN values are recorded.

- ❖ Recording method of Timeplot graph: (page 215)

Types of settings to record data 1



DF2

RECORDING



Rec. Data



Select from pull-down menu



Confirm



Cancel

Rec. Data	ALL DATA	M X/MIN/AVE
Memory Full	STOP	
Interval	1 sec	00 00:05:45
Auto Save	BINARY	

ALL DATA

Records all the calculation values.

P&Harm

Records all calculation values except inter-harmonics.

Power

Records all calculation values except harmonics and inter-harmonics.

If 400 Hz is selected, ALL DATA can not be selected.

1: Power/ 2: P&Harm/ 3: ALL DATA

Recorded item	Pattern	1	2	3
Voltage (one wave shifted over half a wave)		●	●	●
Frequency		●	●	●
RMS voltage value		●	●	●
RMS current value		●	●	●
Voltage waveform peak		●	●	●
Current waveform peak		●	●	●
Active power		●	●	●
Apparent power		●	●	●
Reactive power		●	●	●
Power factor/Displacement power factor		●	●	●
Voltage unbalance factor		●	●	●
Current unbalance factor		●	●	●

1: Power/ 2: P&Harm/ 3: ALL DATA

Recorded item	Pattern	1	2	3
Harmonic voltage		×	●	●
Harmonic current		×	●	●
Harmonic power		×	●	●
Harmonic voltage-current phase difference angle		×	●	●
Inter-harmonic voltage		×	×	●
Inter-harmonic current		×	×	●
Total harmonic voltage distortion factor		●	●	●
Total harmonic current distortion factor		●	●	●
Total inter-harmonic voltage distortion factor		×	×	●
Total inter-harmonic current distortion factor		×	×	●
K factor		●	●	●
Flicker (ΔV_{10} or Pst, PLt)		●	●	●

Types of settings to record data 2

SYSTEM

DF2

RECORDING



MAX/MIN/AVE

(Example)

ENTER

Select from pull-down menu



ENTER

Confirm

ESC

Cancel

**AVE**

Records the average value only.

MAX/MIN/AVE

Records the maximum, minimum, and average values.

You can display the values (MAX, MIN, and AVE values) selected in the Change in RMS value or Change in harmonics time series graphs.

The MAX, MIN, and AVE values are the maximum, minimum, and average calculated values calculated from calculated values included in the interval period.

NOTE

You can always record and display the MAX and MIN values in the change in voltage time series graph, regardless of the selection made here.

❖ [TIME PLOT Recording Method \(page 215\)](#)

Settings when the memory is full

SYSTEM

DF2

RECORDING



Memory Full

ENTER

Select from pull-down menu



ENTER

Confirm

ESC

Cancel

**STOP**

When the internal memory where time series data is saved becomes full, measurement stops.

LOOP

(Continue)

When the internal memory where time series data is saved is exceeded, measurement continues. (Maximum: 1 month) In this case, the oldest time series data in memory is deleted and the new data saved.

Relationship between the internal memory and PC card when the memory is full:

❖ [When the memory is full \(page 153\)](#)

Setting intervals



RECORDING



Interval



Select from pull-down menu



Confirm



Cancel

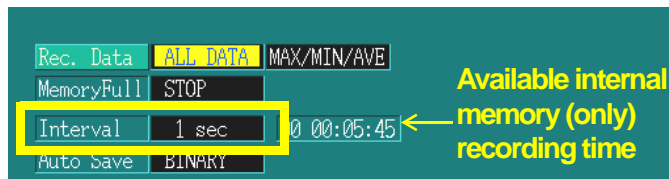

1, 3, 15, or 30 sec, 1, 5, 10, 15, or 30 min, 1/2 hour

Depending on the data recorded and interval settings, the time series graph's possible recording time changes.

- ❖ Types of settings to record data 1 (page 82)
- ❖ Types of settings to record data 2 (page 83)

Possible recording time of the time series graph

Interval	ALL DATA (Saves all data)		P&Harm (Saves RMS values and harmonics)		Power (Saves RMS values only)	
	MAX/MIN/AVE	AVE	MAX/MIN/AVE	AVE	MAX/MIN/AVE	AVE
1 s	5 m 45 s	17 m 12 s	8 m 29 s	25 m 18 s	2 h 1 m 51 s	5 h 32 m 21 s
3 s	17 m 15 s	51 m 36 s	25 m 27 s	1 h 15 m 54 s	6 h 5 m 33 s	16 h 37 m 3 s
15 s	1 h 26 m 15 s	4 h 18 m	2 h 7 m 15 s	6 h 19 m 30 s	1 day 6 h 27 m 45 s	3 days 11 h 5 m 15 s
30 s	2 h 52 m 30 s	8 h 36 m	4 h 14 m 30 s	12 h 39 m	2 days 12 h 55 m 30 s	6 days 22 h 10 m 30 s
1 m	5 h 45 m	17 h 12 m	8 h 29 m	1 day 1 h 18 m	5 days 1 h 51 m	13 days 20 h 21 m
5 m	1 day 4 h 45 m	3 days 14 h	1 day 18 h 25 m	5 days 6 h 30 m	25 days 9 h 15 m	31 days
10 m	2 days 9 h 30 m	7 days 4 h	3 days 12 h 50 m	10 days 13 h	31 days	31 days
15 m	3 days 14 h 15 m	10 days 18 h	5 days 7 h 15 m	15 days 19 h 30 m	31 days	31 days
30 m	7 days 4 h 30 m	21 days 12 h	10 days 14 h 30 m	31 days	31 days	31 days
1 h	14 days 9 h	31 days	21 days 5 h	31 days	31 days	31 days
2 h	28 days 18 h	31 days	31 days	31 days	31 days	31 days

Harmonics order data is not saved for Power, but it is saved in THD.



Measuring for an extended period of time.

Use a Flash ATA card and set the "Auto Save" item to "BINARY."

- When using a 32-MB Flash ATA card: above interval x approximately 2.5
- When using a 64-MB Flash ATA card: above interval x approximately 5

(However, you can only measure for up to 31 days.)

- ❖ Measuring for an extended period of time more than 1 month. Setting the repeated recording (page 87), Setting the number of repeated recording (page 88)

Setting Auto-save



DF2

RECORDING



Auto Save



Select from pull-down menu



Confirm



Cancel

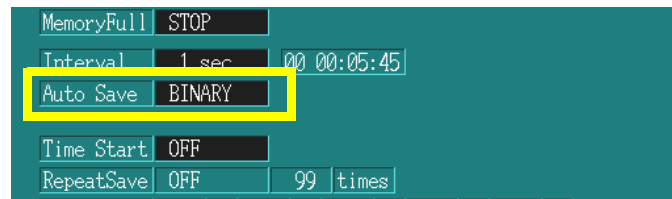

OFF, BINARY, TEXT

You can set the 3196 to save data automatically to the PC card.

- ❖ File Types (page 145)
- ❖ Saving and Loading Files (page 147)

When BINARY or TEXT is selected, measurement data is recorded to PC card as well as internal memory.

NOTE

After measurement, the measurement data in internal memory can be saved manually in binary or text format.

- ❖ Manual saving of the measured data files 1 (Binary format: all data) (page 149)
- ❖ Manual saving of the measured data files 2 (Text format: time-series/ event list/ flicker data) (page 150)

Setting real-time control



DF2

RECORDING

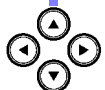

Time Start

(Real-time control)



Select from pull-down menu



Confirm



Cancel

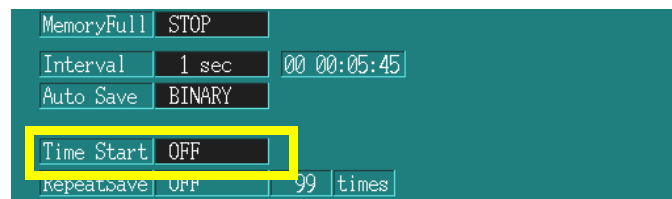

OFF Measurement starts or stops when you press the START/STOP key.

ON Measurement starts or stops at the set measurement start/stop time.

When ON is selected:

[SETTING] [WAITING] [RECORDING] [ANALYZING]

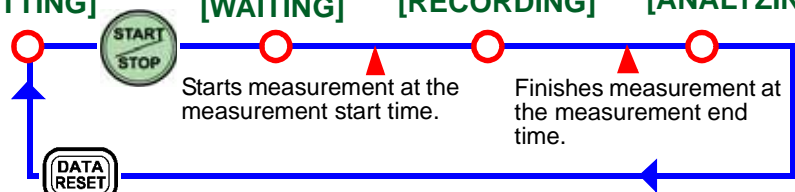

When you want to stop measurement:

Press the button again.



Setting measurement start/stop time

SYSTEM

DF2

RECORDING



Start Time

Stop Time

ENTER



Numeric value settings



Change columns

ENTER

Confirm

ESC

Cancel

Time Start	OFF
Repeat/Save	OFF 00 Times
Start Time	2002 Y 9 M 5 D 0 h 0 m
Stop Time	2002 Y 9 M 11 D 23 h 59 m

When Manual setting: Set the values

When Automatic settings:

Start time Set to the current time.

Stop time Set to **1 hour** after the start time.

Set to **1 day** after the start time.

Set to **1 week** after the start time.

An error message appears when is pressed and the set measurement start time has already passed.

Setting the repeated recording

Repeated recording operations can be conducted up to 99 days at one-day measuring intervals, and up to 99 weeks at one-week measuring intervals.

The measured data file of repeated recording is saved as a separate binary file for each one-day or one-week period on the PC card.

The repeated recording function utilizes “continuous measurement with full internal memory,” “real time control,” and “auto-save on PC card.”

To set the repeated recording function, make the following settings. Without these settings, the repeated recording function cannot be used.

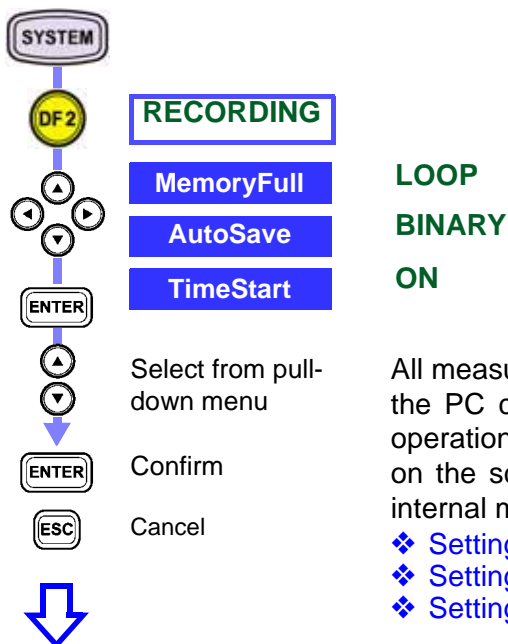

All measured data collected by repeated recording is stored on the PC card, but previous data is cleared in each recording operation and not retained in internal memory (data displayed on the screen). Therefore, only the latest data is retained in internal memory at any given time.

- ❖ [Settings when the memory is full \(page 83\)](#)
- ❖ [Setting Auto-save \(page 85\)](#)
- ❖ [Setting real-time control \(page 85\)](#)

Make repeated recording settings

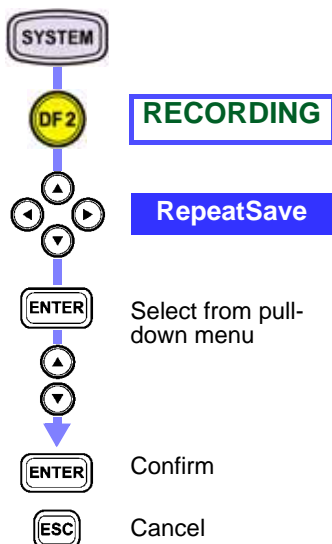

Time Start	OFF										
RepeatSave	OFF	99	times								
Start Time	2002	Y	9	M	5	D	0	h	0	m	
Stop Time	2002	Y	9	M	11	D	23	h	59	m	

- OFF** No repeated recording
- 1 Day** Repeated recording at one-day intervals
- 1 Week** Repeated recording at one-week intervals

Time Start	ON										
RepeatSave	1 Week	99	times	137	MB+events						
Start Time	2002	Y	9	M	5	D	0	h	0	m	
Stop Time	2002	Y	9	M	11	D	23	h	59	m	

Setting the number of repeated recording

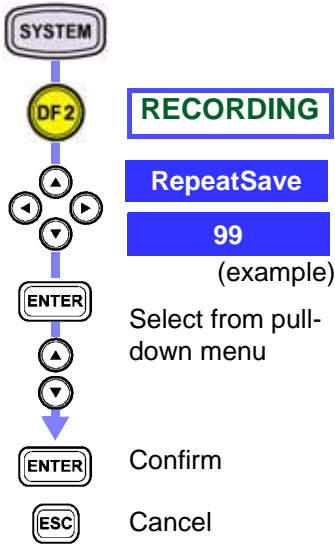

Indicates required PC card file capacity.

1 to 99

- ⬆ Increases the value
- ⬇ Lowers the value

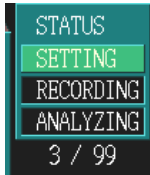

When the repeated recording function is set, the number of repeated recording operations currently set will be indicated.

(Example)

When number of repeated recording operations is set to "99"

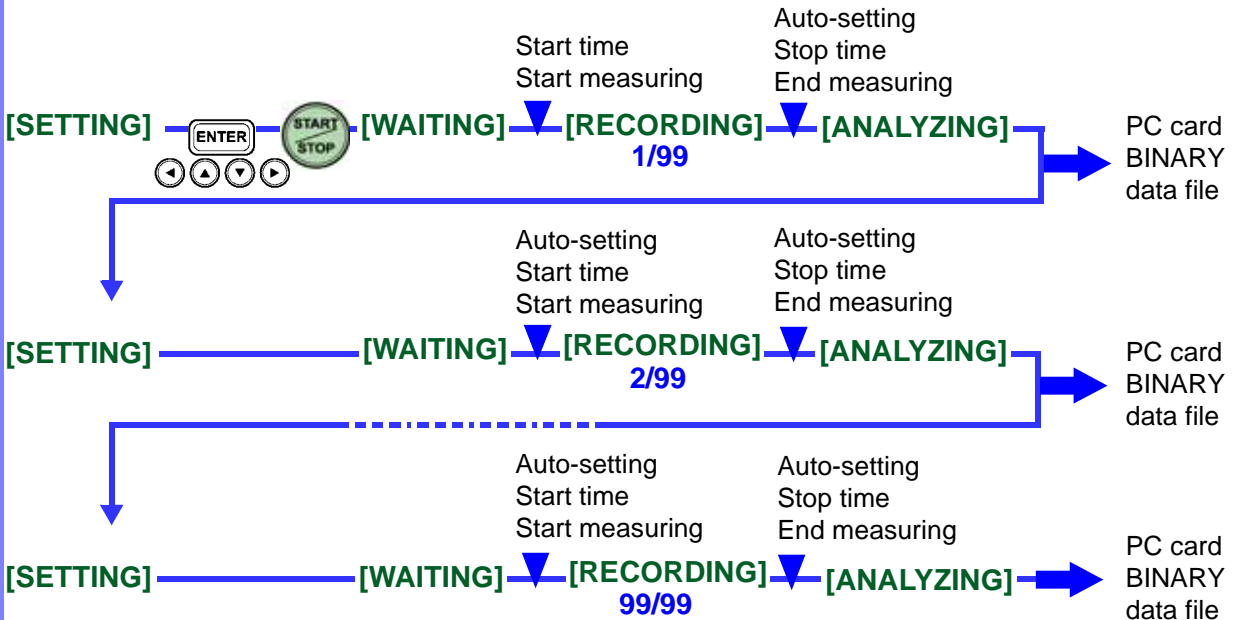

NOTE

To set the start time, enter the start time of the first recording operation in repeated recording. The start and end times of subsequent repeated recording operations are then set automatically. Note that each repeated recording operation results in a measuring deviation of one minute.

6.3 Changes in RMS Value

Display items calculated by the 3196 at 200 ms intervals can be displayed in a time series for each interval.

Example: 3P4W (three-phase four-wire)

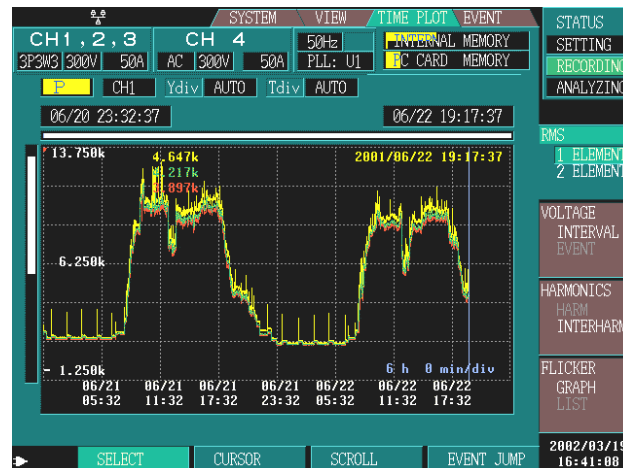
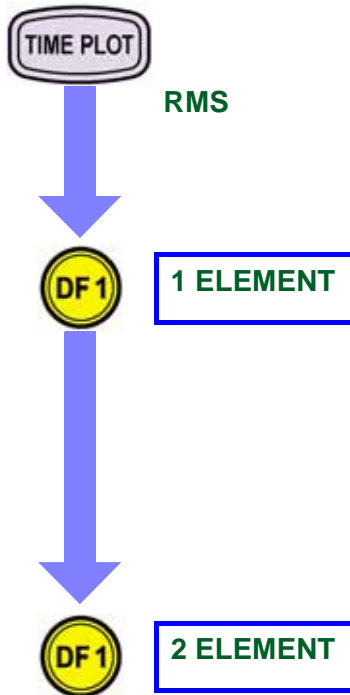

You can select a single item from the display items to be displayed in the time series graph.

Yellow: MAX value
Green: AVE value
Red: MIN value



You can select two items from the display items to be displayed in the time series graph.

Yellow: MAX value
Green: AVE value
Red: MIN value



- ❖ Changing the display item (page 90)
- ❖ Changing the display channel (page 90)
- ❖ Changing the Y-axis scale (page 91)
- ❖ Changing the X-axis scale (page 91)
- ❖ Cursor measurements (page 91)
- ❖ Scrolling through waveforms (page 92)
- ❖ Searching for events (page 92)

MAX, MIN, and AVE indicate the maximum, minimum, and average during the interval.

NOTE

- When you select **AVE** in the data type settings as the recorded data ([SYSTEM]-DF2[RECORDING]), a time series graph is displayed for the AVE value only instead of three types of time series graphs being displayed for the MAX, AVE, and MIN values as above.
- When using the time series graph to observe swells, dips, and interruptions, and to record ΔU deviation with respect to the nominal voltage, use



VOLTAGE.

Changing the display item



SELECT



Freq

(Example)



Select from pull-down menu



Confirm



Cancel

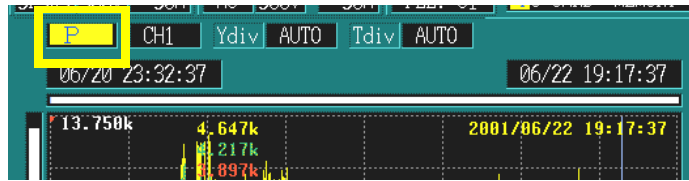

Freq	Frequency	Q	Reactive power
U	Voltage	PF	Power factor
Upeak+	Voltage waveform peak (+)	KF	K factor
Upeak-	Voltage waveform peak (-)	Uunb	Voltage unbalance factor
I	Current	Iunb	Current unbalance factor
Ipeak+	Current waveform peak (+)	U-THD	Total harmonic voltage distortion factor
Ipeak-	Current waveform peak (-)	I-THD	Total harmonic current distortion factor
Uave	Average voltage value	U-iTHD	Total inter-harmonic voltage distortion factor
Iave	Average current value	I-iTHD	Total inter-harmonic current distortion factor
P	Active power		
S	Apparent power		

peak: waveform peak, ave: average value between channels.

NOTE

Depending on the following settings, some items cannot be selected.

Setting item	Settings	Selection not possible
Recorded data	Power or P&Harm	U-iTHD, I-iTHD
Connection	1P2W	Uave, Iave, Uunb, Iunb
	1P3W, 3P3W2M	Uunb, Iunb

If the PLL unlocks due to a momentary power outage or another reason, the set frequency is displayed and recorded during the momentary power outage.

Changing the display channel



SELECT



CH1

(Example)



Select from pull-down menu



Confirm



Cancel



CH1, CH2, CH3, CH4: Channel
sum: Total for all channels

NOTE

If the connection method settings (4 channels) are off, you cannot select CH4.

Changing the Y-axis scale

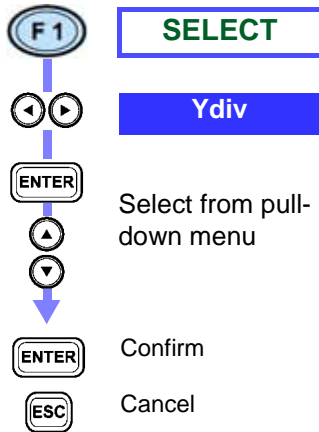

AUTO, x1, x2, x5, x10, x25, x50

When you want to reduce the graph, make the scale smaller. When you want to enlarge the graph, make the scale larger.

When recording, use AUTO.

Changing the X-axis scale

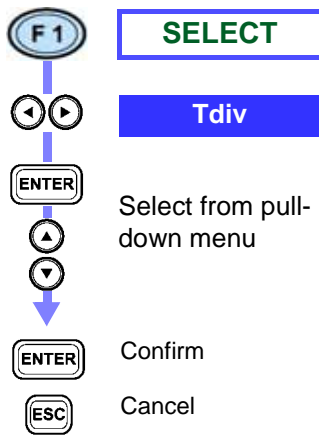

AUTO, x1, x1/2, x1/4, x1/8, x1/16, x1/32, x1/64

When you want to reduce the graph, make the scale smaller. When you want to enlarge the graph, make the scale larger.

When recording, use AUTO.

Cursor measurements

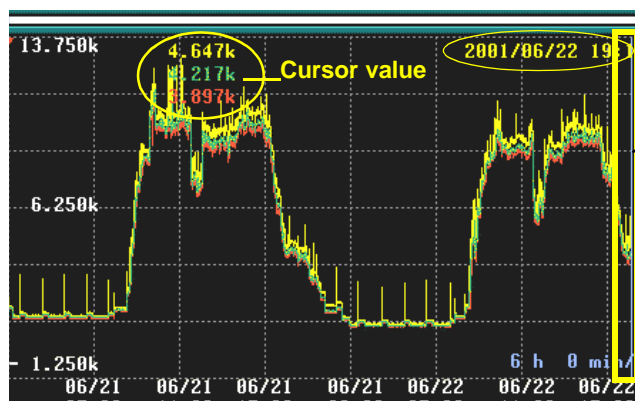
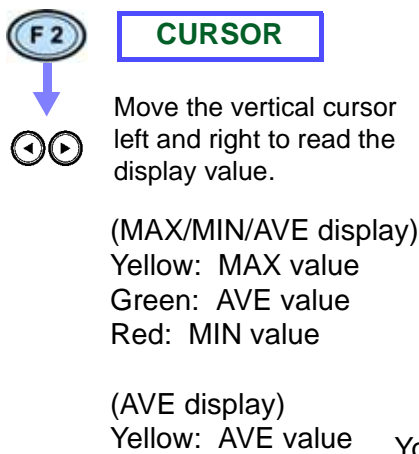

You can read the value above the cursor and the time on the time series graph.

Scrolling through waveforms

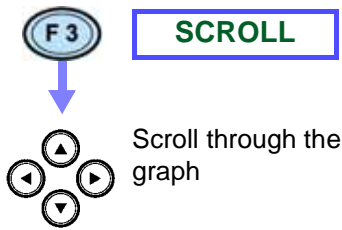

Waveform display range

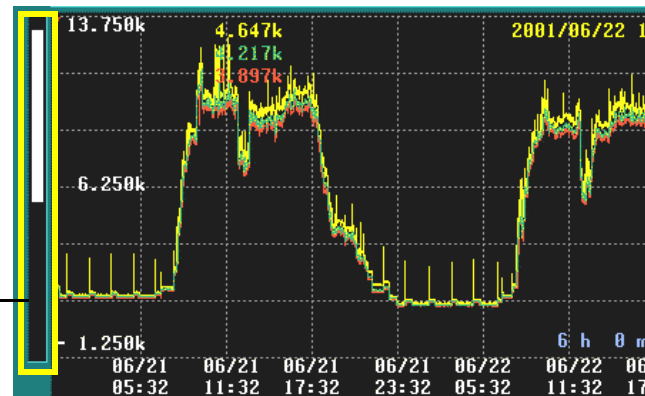

Scroll bar

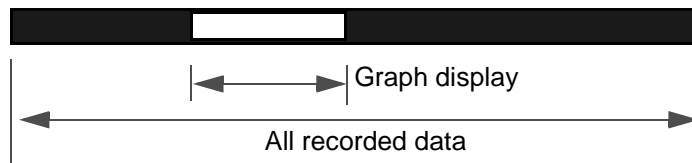

The waveform display range (white belt) on the scroll bar indicates what interval of recorded data is displayed on the screen.

When AUTO is set during recording, the X-axis and Y-axis are automatically scaled so that all the time series graphs are displayed on the screen.

When measurement stops, if you change the X-axis scale, you can scroll through the time series graph in every direction.

Searching for events



Skips sideways through the event markers.

Analyzing events using waveforms

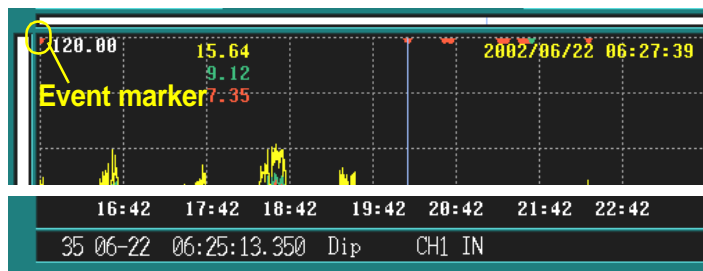

Synchronization is achieved with an event selected from the event list.

You can search for the time the event occurred (event marker ▼).

The start time and stop time event markers are always displayed.

Event marker

▼ (red): Indicates an ordinary event.

▼ (blue): Indicates an event for which an event voltage fluctuation graph is recorded.

6.4 Changes in Voltage

6.4.1 Graphing Voltage Fluctuations for Each Interval



VOLTAGE

INTERVAL

You can display interval-by-interval time series graphs of voltages ($\Delta U, S(t)$) as well as Urms) internally calculated from single half cycle-shifted waveforms

Example: 3P4W (three-phase four-wire)

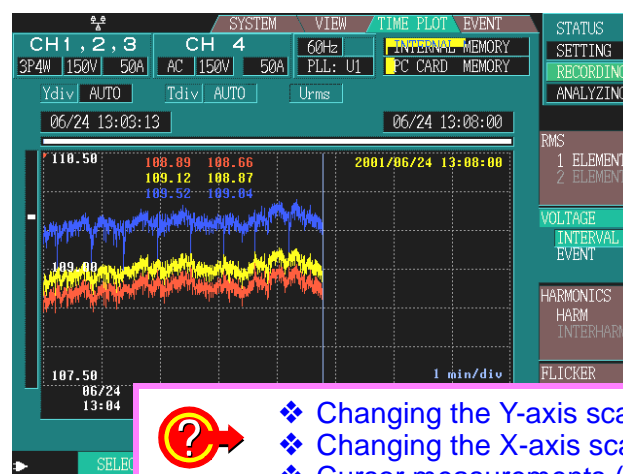

Displays a time series graph for U1, U2, and U3.

Modified values are displayed as MAX and MIN values.

Red: U1

Yellow: U2

Blue: U3



- ❖ Changing the Y-axis scale (page 94)
- ❖ Changing the X-axis scale (page 94)
- ❖ Cursor measurements (page 94)
- ❖ Scrolling through waveforms (page 95)
- ❖ Searching for events (page 95)

- When Urms is selected as the voltage recording setting (SYSTEM-DF2[MEASURE]):
The RMS voltage detected for swell, dip, and interruption is displayed.
The cursor value of the event marker area on the time series graph is the same as the swell, dip, or interruption value.
- When Pst, Plt is selected
The instantaneous flicker defined in IEC 61000-4-15 is displayed.
- When ΔU is selected as the voltage recording setting (SYSTEM-DF2[MEASURE]):
The deviation in RMS voltage to nominal voltage (positive and negative voltage waveform peaks for nominal voltage) is displayed.

MAX and MIN indicate the maximum and minimum during the interval.

NOTE

When you select **MAX/MIN/AVE** or **AVE** in the data type settings as recorded data ([SYSTEM]-DF2[RECORDING]), the MAX and MIN values are displayed in a time series graph.

Note that the MAX and MIN values are displayed in a single graph for changes in voltage instead of the MAX, MIN, and AVE values displayed in three graphs as for changes in RMS value.

Changing the Y-axis scale

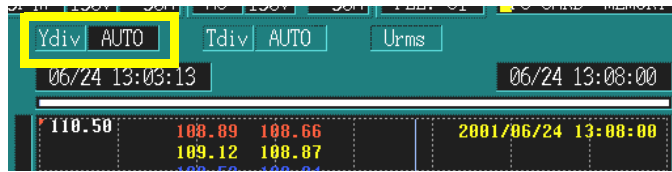
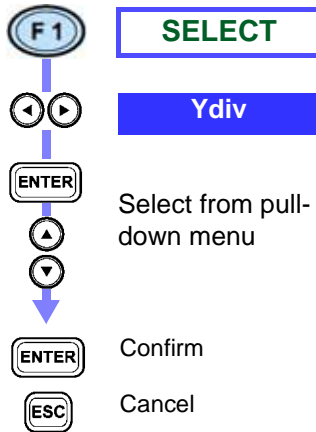

AUTO, x1, x2, x5, x10, x25, x50

When you want to reduce the graph, make the scale smaller. When you want to enlarge the graph, make the scale larger.

AUTO scaling is used during recording.

Changing the X-axis scale

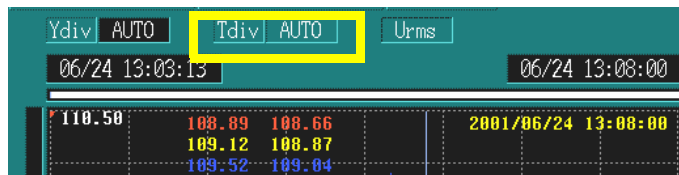
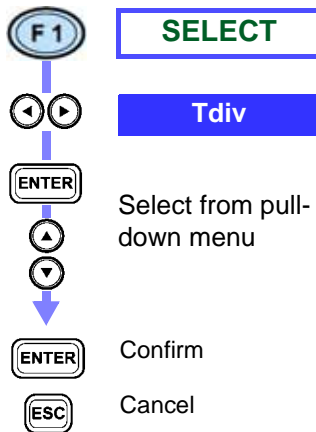

AUTO, x1, x1/2, x1/4, x1/8, x1/16, x1/32, x1/64

When you want to reduce the graph, make the scale smaller. When you want to enlarge the graph, make the scale larger.

AUTO scaling is used during recording. This cannot be changed.

Cursor measurements

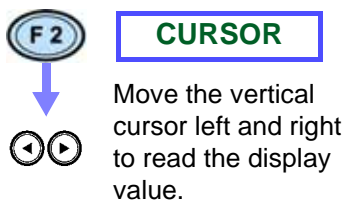

- Left side (MAX value)
 - Red: U1
 - Yellow: U2
 - Blue: U3
- Right side (MIN value)
 - Red: U1
 - Yellow: U2
 - Blue: U3

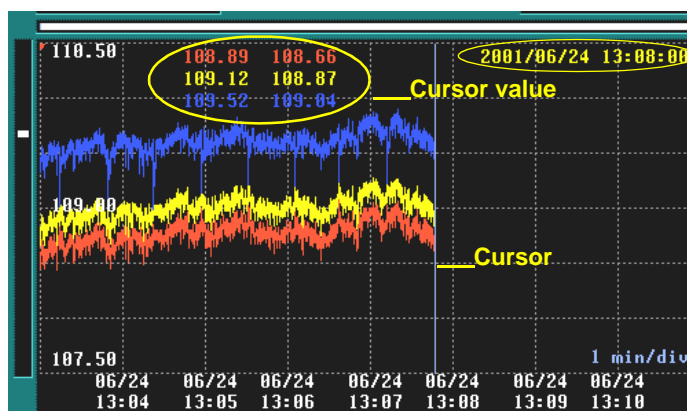

You can read the value above the cursor and the time on the time series graph.

Scrolling through waveforms

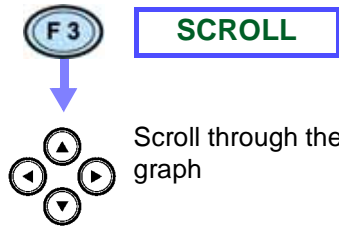

Waveform display range

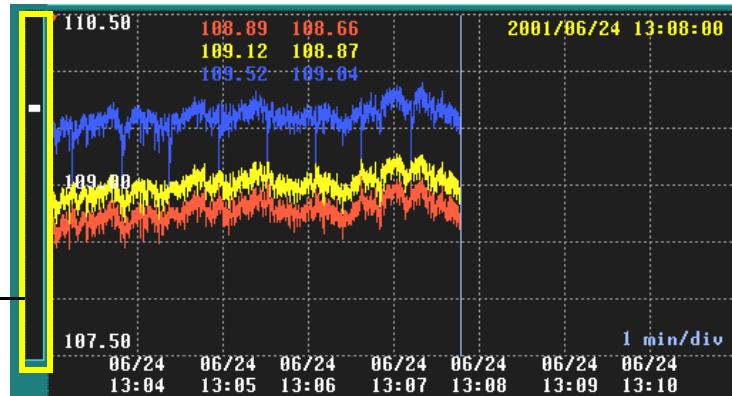

Cursor position

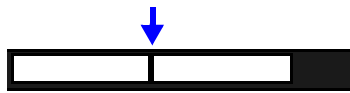

The cursor on the scroll bar indicates where the cursor is positioned on the all recorded data.

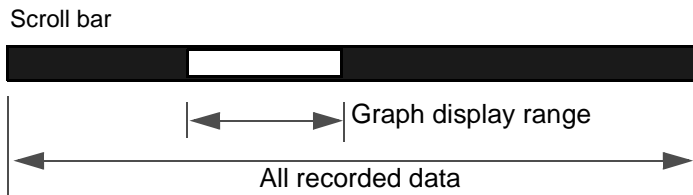

The graph display range (white belt) on the scroll bar indicates what interval of recorded data is displayed on the screen.

When AUTO is set during recording, the X-axis and Y-axis are automatically scaled so that all the time series graphs are displayed on the screen.

If you change the X/Y-axis scale, you can scroll through the time series graph in every direction.

Searching for events

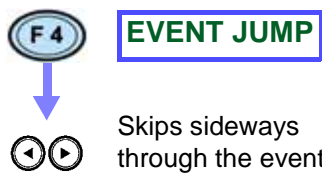

Analyzing events using waveforms

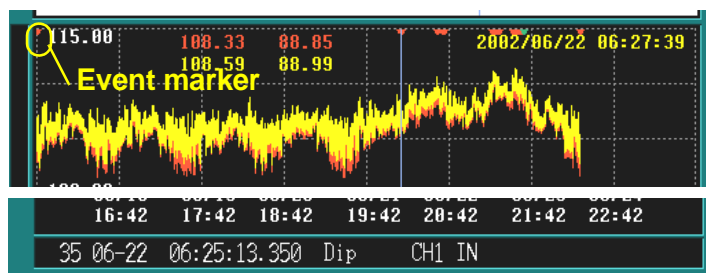

Synchronization is achieved with an event selected from the event list.

You can search for the time the event occurred (event marker ▼).

The start time and stop time event markers are always displayed.

Event marker

- ▼ (red): Indicates an ordinary event.
- ▼ (blue): Indicates an event for which an event voltage fluctuation graph is recorded.

6.4.2 Graphing Voltage Fluctuations for Events

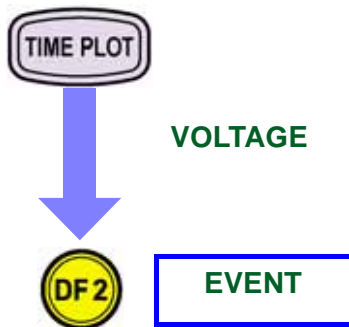

When an event occurs, the voltage calculated by the 3196 for a single waveform shifted half a wave can be displayed in a time series graph spanning 10 seconds.

Example: 1P2W (single-phase two-wire)

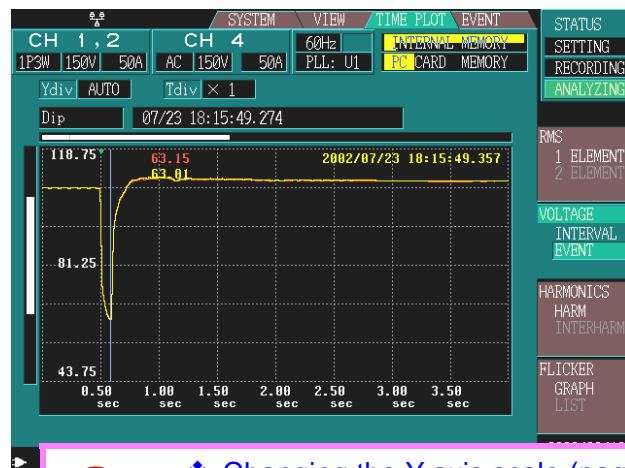

Displays a time series graph for U1, U2, and U3.

Pre-trigger is fixed to 0.5 second and overall recording length to 10 seconds.

Red: U1
Yellow: U2
Blue: U3



- ❖ Changing the Y-axis scale (page 97)
- ❖ Changing the X-axis scale (page 97)
- ❖ Cursor measurements (page 97)
- ❖ Scrolling through waveforms (page 98)
- ❖ Displaying voltage fluctuation event graphs stored on a PC card (page 98)
- ❖ Automatically recording multiple voltage fluctuation event graphs on a PC card (page 99)

The only events that are valid for recording are voltage swells, voltage dips, and voltage interruptions.

Only one voltage fluctuation event graph is recorded in internal memory.

By using a PC card, you can record and display multiple voltage fluctuation event graphs.

NOTE

- Recording is possible regardless of the recording data type settings and interval setting (SYSTEM-DF2[RECORDING]).
- When measuring at 400 Hz, maximum and minimum values are calculated from every eight data values at each cycle.

Changing the Y-axis scale

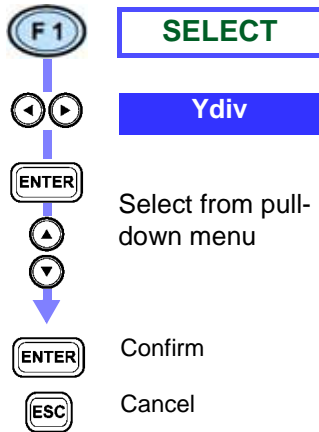

AUTO, x1, x2, x5, x10, x25, x50

When you want to reduce the graph, make the scale smaller. When you want to enlarge the graph, make the scale larger.

AUTO scaling is used during recording.

Changing the X-axis scale

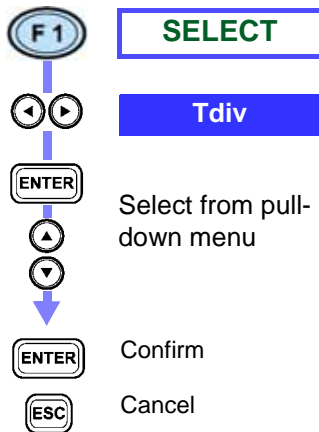

AUTO, x5, x2, x1, x1/2, x1/4, x1/8, x1/16, x1/32, x1/64

When you want to reduce the graph, make the scale smaller. When you want to enlarge the graph, make the scale larger.

AUTO scaling is used during recording. This cannot be changed.

Cursor measurements

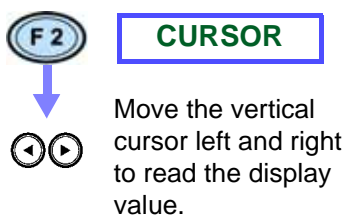

Red: U1
Yellow: U2
Blue: U3

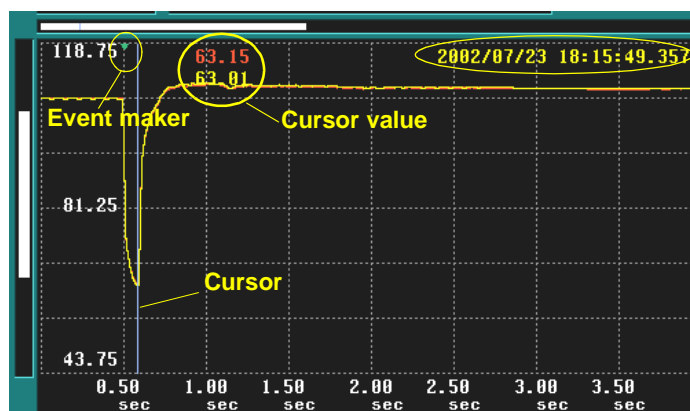

You can read the value above the cursor and the time on the time series graph.

Scrolling through waveforms

F3

SCROLL

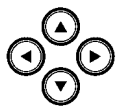

Scroll through the graph

Waveform display range

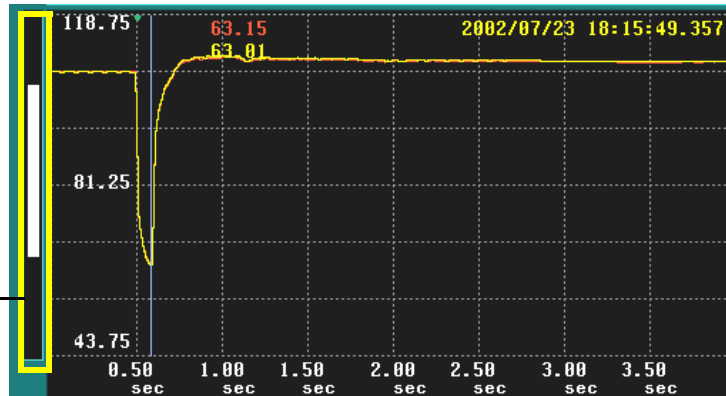

Cursor position

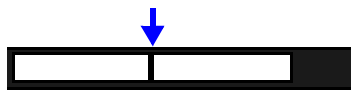

The cursor on the scroll bar indicates where the cursor is positioned on the all recorded data.

Scroll bar

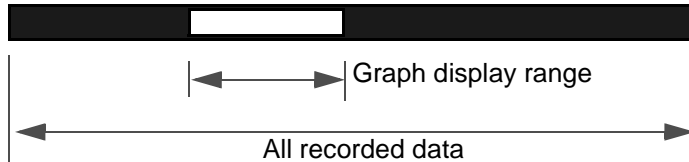

The graph display range (white belt) on the scroll bar indicates what interval of recorded data is displayed on the screen.

When AUTO is set during recording, the X-axis and Y-axis are automatically scaled so that all the time series graphs are displayed on the screen.

If you change the X/Y-axis scale, you can scroll through the time series graph in every direction.

Displaying voltage fluctuation event graphs stored on a PC card

F4

NEXT FILE

You can read and display voltage fluctuation event graphs recorded on a PC card.

Each depression of this key reads the next in a series of voltage fluctuation event graph on the PC card.

This operation is only possible in the following circumstances.

- When a PC card is inserted during analysis
- When voltage fluctuation event data is recorded on the PC card in binary format

It is also possible to analyze data stored on the PC card after loading all binary measurement files into the analyzer. (However, the PC card must be left in the analyzer during operation as data is read at each stage.)

Automatically recording multiple voltage fluctuation event graphs on a PC card

Only one voltage fluctuation event graph is recorded in internal memory.

By using a PC card, you can record multiple voltage fluctuation event graphs.

When BINARY (binary format) or TEXT (text format) is selected as the auto save option, measurement files are automatically recorded on the PC card.

Method of Auto-save settings:

- ❖ [Measured data files Auto-save \(binary format\) settings \(page 152\)](#)
- ❖ [Auto-save measured data file \(text format\) settings \(page 154\)](#)

6.5 Changes in Harmonics

You can select six orders and display them in a harmonics time series graph.

Example: 3P4W (three-phase four-wire)

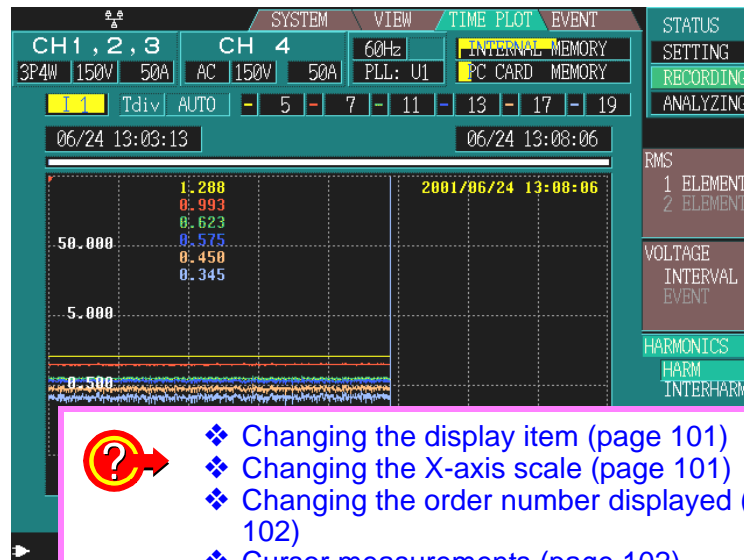
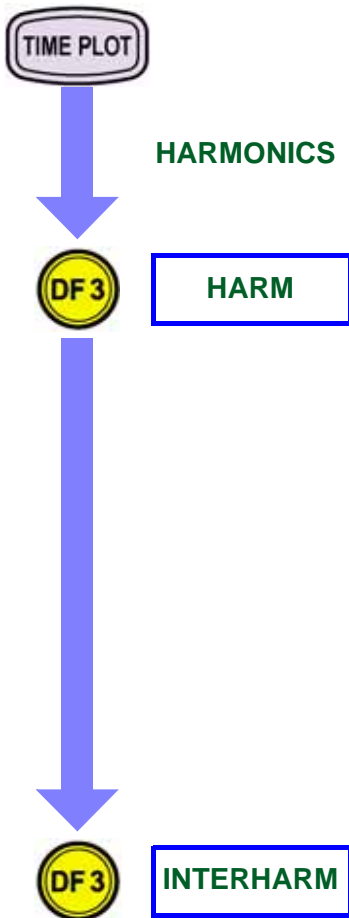

- ❖ Changing the display item (page 101)
- ❖ Changing the X-axis scale (page 101)
- ❖ Changing the order number displayed (page 102)
- ❖ Cursor measurements (page 102)
- ❖ Scrolling through waveforms (page 103)
- ❖ Searching for events (page 103)



NOTE

- When **Power** is selected in the recorded item settings (SYSTEM-DF2[RECORDING]) as recorded data, you cannot display the harmonics time series graph. Also, when **Power** or **P&Harm** is selected, you cannot display the changes in harmonics time series graph for inter-harmonics.
- When you select **MAX/MIN/AVE** in the data type settings (SYSTEM-DF2[RECORDING]) as recorded data, the MAX and MIN values are displayed in a single graph.
- When the 400 Hz measurement frequency is selected, harmonic analysis is performed up to the 10th order, and inter-harmonic analysis is not available.

Changing the display item

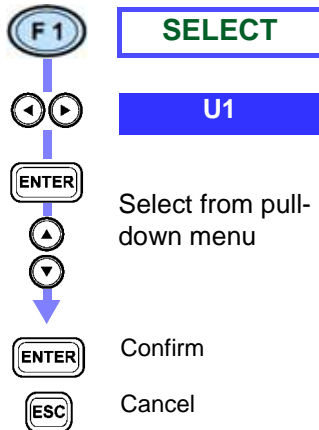

U1, U2, U3, U4	Voltage (CH1/2/3/4)
I1/I2/I3/I4	Current (CH1/2/3/4)
P1/P2/P3	Active power (CH1/2/3/)
Psum	Total active power
θ1/θ2/θ3	Phase difference (CH1/2/3)
θsum	Total phase difference

The display items that can be selected differ depending on the connection method.

θ indicates the phase difference between the voltage and the current for that channel.

NOTE

You can only select U1, U2, U3, U4, I1, I2, I3, and I4 in the inter-harmonic time series graph.

Changing the X-axis scale

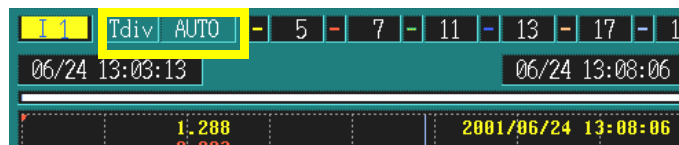
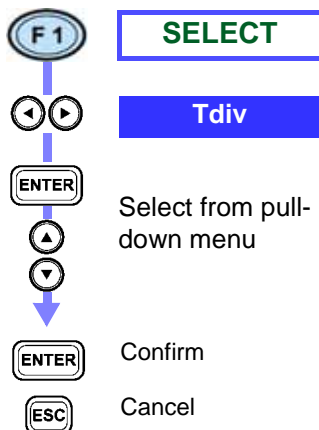

AUTO, x1, x1/2, x1/4, x1/8, x1/16, x1/32, x1/64

When you want to reduce the graph, make the scale smaller. When you want to enlarge the graph, make the scale larger.

AUTO scaling is used during recording. This cannot be changed.

NOTE

The Y-axis scale cannot be changed. The maximum value for the Y-axis is the same as the full-scale range value.

Changing the order number displayed

F1

SELECT

← →

1

(Example)

ENTER

Select from pull-down menu

↑

↓

ENTER

Confirm

ESC

Cancel



OFF, 1 to 50 (When harmonics DF3[HARM] is selected)
OFF, 0.5 to 49.5 (When Inter-harmonics DF3[INTERHARM] is selected)

You can select up to six orders and display them simultaneously.

Cursor measurements

F2

CURSOR

← →

Move the vertical cursor left and right to read the display value.

The cursor value is the same color as the selected order.

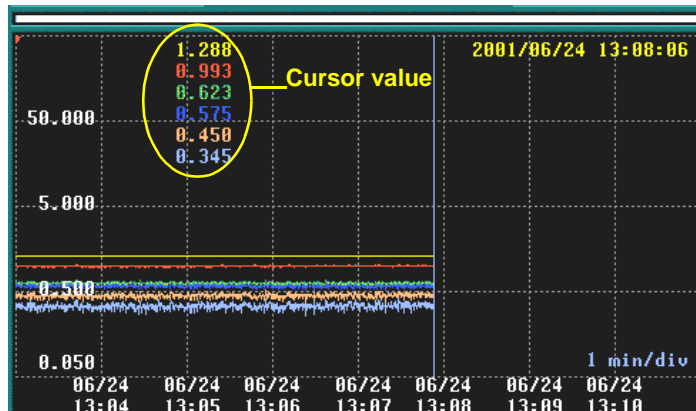

You can read the value above the cursor and the time on the time series graph.

NOTE

When **MAX/MIN/AVE** is selected in the data type settings (SYSTEM-DF2[RECORDING]) as recorded data, the cursor values indicate MAX values, and when **AVE** is selected, AVE values are indicated.

Scrolling through waveforms



SCROLL



Scroll through the graph

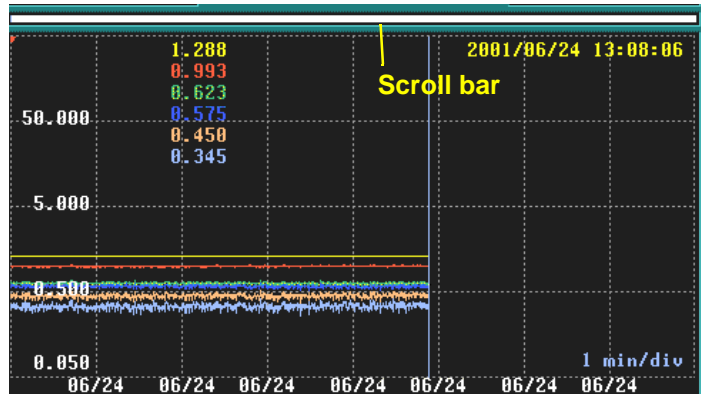

Cursor position

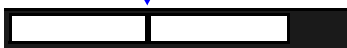

The cursor on the scroll bar indicates where the cursor is positioned on the all recorded data.

Scroll bar

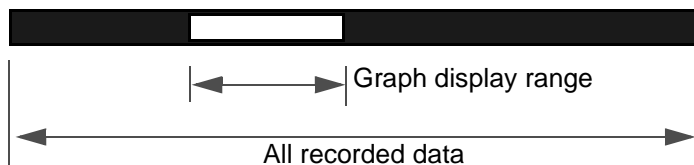

The graph display range (white belt) on the scroll bar indicates what interval of recorded data is displayed on the screen.

During measurement, the Y-axis is automatically scaled so that all the time series graphs are displayed on the screen.

When measurement stops, if you change the X-axis scale, you can scroll the time series graph right and left.

Searching for events



EVENT JUMP



Skips sideways through the event markers.

Analyzing events using waveforms



Synchronization is achieved with an event selected from the event list.

You can search for the time the event occurred (event marker ▼).

The start time and stop time event markers are always displayed.

Event marker

▼ (red): Indicates an ordinary event.

▼ (blue): Indicates an event for which an event voltage fluctuation graph is recorded.

6.6 Flicker

NOTE

Flicker analysis is not available when measuring 400 Hz.

6.6.1 IEC Flicker Meter and $\Delta V10$ Flicker Meter

A flicker meter is a device for measuring perceived instability in light resulting from variations in lighting brightness and wavelength. There are two types of flicker meters: the IEC flicker meter (UIE flicker meter), which is based on the IEC standard; and the $\Delta V10$ flicker meter, which is used primarily in Japan. Both types of flicker meter observe fluctuations in voltage and display a numeric value as an objective measure of flicker.

IEC Flicker Meter

The IEC flicker function is based on international standard IEC61000-4-15, "Flickermeter - Functional and design specifications".

Functional diagram of the IEC flicker meter

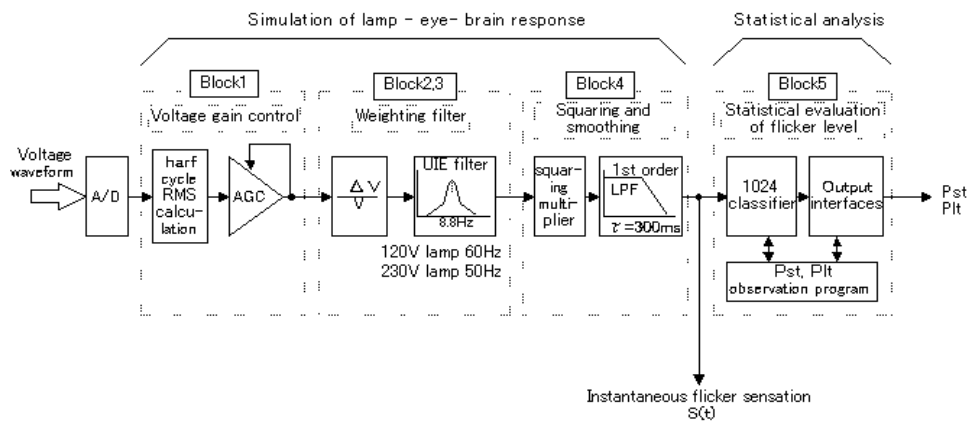

RMS value

Urms

The RMS voltage (U_{rms}) that is used by the IEC flicker meter is calculated every half cycle.

Auto Gain Controller

AGC

This circuit adjusts the input RMS voltage (U_{rms}) to a constant level without affecting the variable voltage component. The circuit has a 60-second response time (the time over which the fluctuation width changes from 10% to 90%) with respect to stepped variations in U_{rms} .

Weighting Filter

Processing uses one of three selectable weighting filters, a filter for 230 V lamp, 50 Hz systems, a filter for 120 V lamp, 60 Hz systems, and a filter for 100 V lamp, 50 Hz or 60 Hz systems.

$$\frac{k\omega_1 s}{\omega^2 + 2\lambda S + \omega_1^2} \cdot \frac{1 + s/\omega_2}{(1 + s/\omega_3)(1 + s/\omega_4)}$$

- 230 V lamp 50 Hz system
 - k = 1.74802
 - $\lambda = 2\pi 4.05981$
 - $\omega_1 = 2\pi 9.15494$
 - $\omega_2 = 2\pi 2.27979$
 - $\omega_3 = 2\pi 1.22535$
 - $\omega_4 = 2\pi 21.9$
- 120 V lamp 60 Hz system
 - k = 1.6357
 - $\lambda = 2\pi 4.167375$
 - $\omega_1 = 2\pi 9.077169$
 - $\omega_2 = 2\pi 2.939902$
 - $\omega_3 = 2\pi 1.394468$
 - $\omega_4 = 2\pi 17.31512$
- 100 V lamp 50 Hz or 60 Hz system
 - k = 1.52067
 - $\lambda = 2\pi 4.05217$
 - $\omega_1 = 2\pi 9.01508$
 - $\omega_2 = 2\pi 4.12991$
 - $\omega_3 = 2\pi 1.68945$
 - $\omega_4 = 2\pi 18.9417$

Statistical Processing

Statistics on flicker are compiled by applying the cumulative probability function (CPF) to 1,024 logarithmic divisions of instantaneous flicker values S(t) in the range from 0.0001 to 10000 P.U. to obtain cumulative probabilities P0.1, P1s, P3s, P10s, and P50s.

Short Interval Flicker Value

Pst

This indicates degree of perceptibility (severity) of flicker measured over a 10-minute period.

Calculation:

$$Pst = \sqrt{0.0314P0.1 + 0.0525P1s + 0.0657P3s + 0.28P10s + 0.08P50s}$$

$$P50s = (P30 + P50 + P80)/3$$

$$P10s = (P6 + P8 + P10 + P13 + P17)/5$$

$$P3s = (P2.2 + P3 + P4)/3$$

$$P1s = (0.7 + P1 + P1.5)/3$$

P0.1 is not smoothed

Long Interval Flicker Value

Plt

Indicates the degree of perceptibility (severity) of flicker determined from successive Pst measurements over a 2-hour period.

To calculate a moving average of Pst, the displayed value is updated every 10 minutes.

Calculation:

$$Plt = \sqrt[3]{\frac{\sum Psti^3}{N}}$$

ΔV_{10} Flicker Meter

ΔV_{10} Flicker

The ΔV_{10} flicker function is calculated using the “perceived flicker curve” calculation method, which is based on digital Fourier transformation.

Calculation:

$$\Delta V_{10} = \sqrt{\sum_{n=1}^{\infty} (a_n \cdot \Delta V_n)^2}$$

ΔV_n : RMS value [V] for voltage fluctuations in frequency f_n .

a_n : Luminosity coefficient for f_n where 10 Hz is 1.0.
(0.05Hz to 30Hz)

Evaluation period: for 1 minute

ΔV_{10} Perceived flicker curve

ΔV_{10} Perceived flicker coefficient

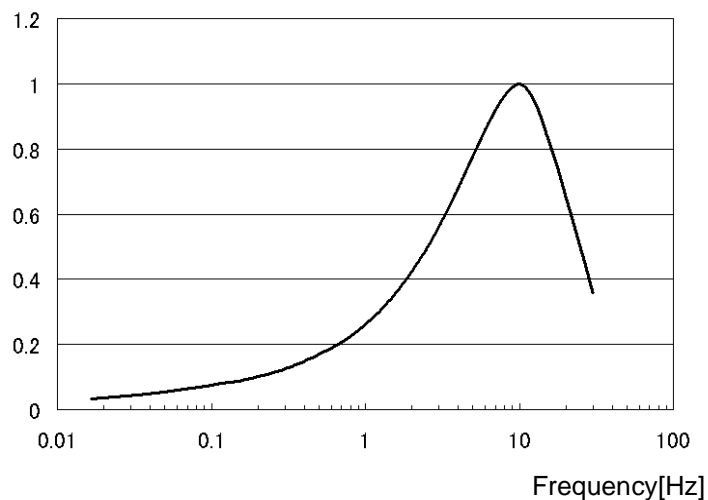

To measure the IEC Flicker or ΔV_{10} Flicker

Set the flicker calculation, voltage recording method, IEC flicker filter, and ΔV_{10} flicker measurement channel in **SYSTEM - DF2[MEASUREMENT]**.

- ❖ [Flicker calculation settings \(page 56\)](#)
- ❖ [Voltage recording method settings \(page 56\)](#)
- ❖ [IEC flicker filter settings \(page 57\)](#)
- ❖ [\$\Delta V_{10}\$ flicker measurement channel settings \(page 57\)](#)

6.6.2 IEC Flicker Graph

Displays the IEC flicker graph.

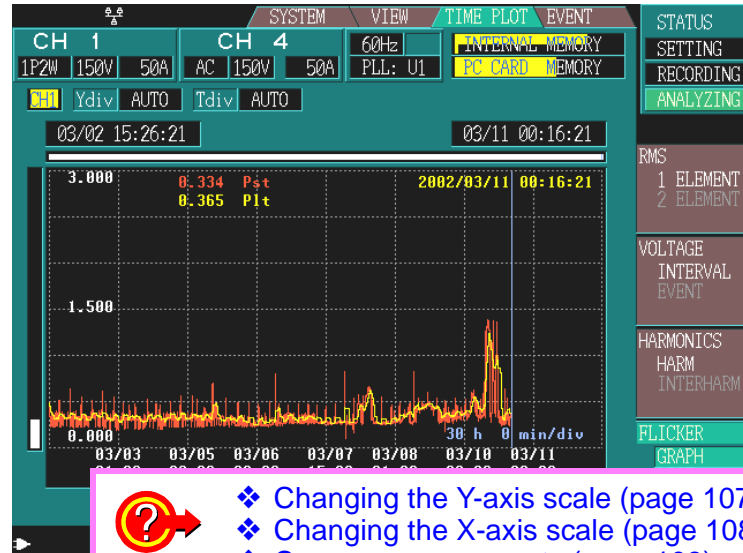
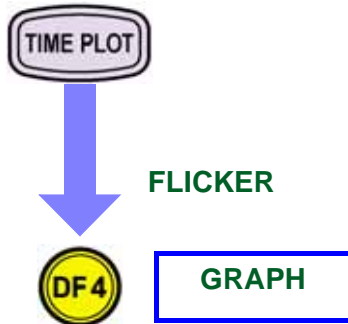

- ❖ Changing the Y-axis scale (page 107)
- ❖ Changing the X-axis scale (page 108)
- ❖ Cursor measurements (page 108)
- ❖ Scrolling through waveforms (page 109)

NOTE

- The graph is updated every 10-minute, regardless of the interval that is set for **[SYSTEM]-DF2[MAIN]-[RECORDING]**.
- After you press , the clock displays "00" seconds and measurement starts.
- This is only displayed if Pst,Plt is selected for Flicker in **[SYSTEM]-DF2[MAIN]-[MEASURE]**.
- A fluctuation graph of S(t) is displayed in the **DF2[VOLTAGE]** screen. However, this graph is not displayed unless S(t) is selected for voltage recording with **[SYSTEM]-DF2[MAIN]-[MEASURE]**.

Changing the Y-axis scale

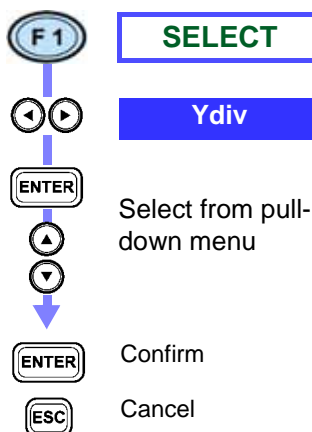

Select from pull-down menu

Confirm

Cancel



AUTO, x1, x2, x5, x10, x25, x50

When you want to reduce the graph, make the scale smaller.
When you want to enlarge the graph, make the scale larger.

AUTO scaling is used during recording.

Changing the X-axis scale

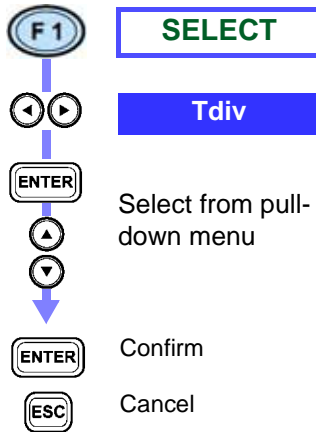

Select from pull-down menu

Confirm

Cancel



AUTO, x1, x1/2, x1/4, x1/8, x1/16, x1/32, x1/64

When you want to reduce the graph, make the scale smaller. When you want to enlarge the graph, make the scale larger.

AUTO scaling is used during recording. This cannot be changed.

Cursor measurements

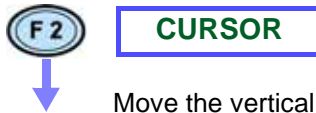

Move the vertical cursor left and right to read the display value.

Upper: Pst measured value
Lower: Plt measured value

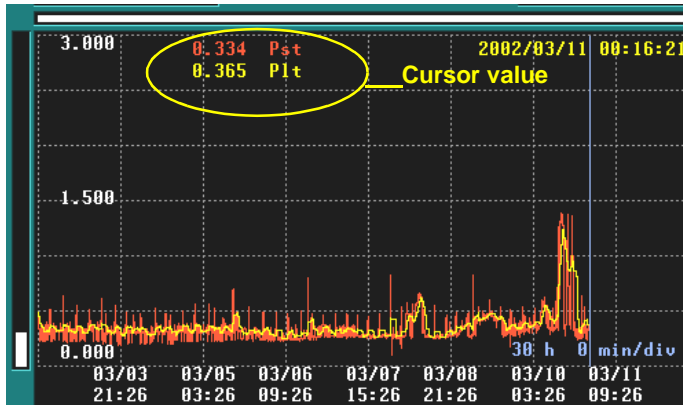

Measured values of Pst and Plt can be read every 10 minutes.

Scrolling through waveforms

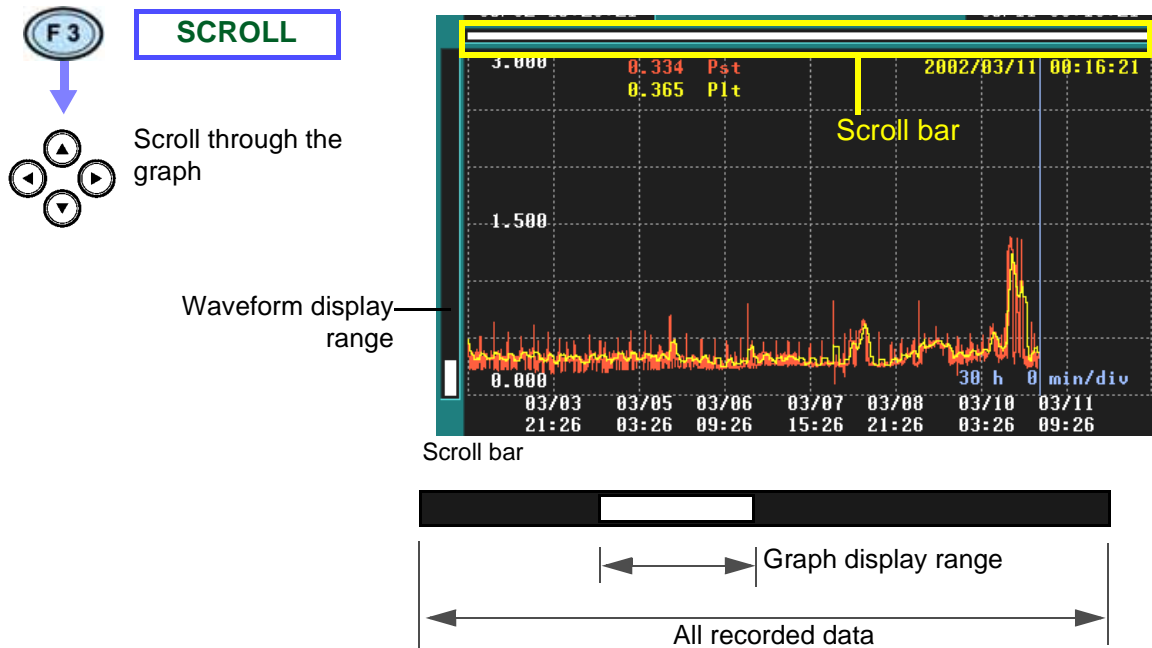

The waveform display range (white belt) on the scroll bar indicates what interval of recorded data is displayed on the screen.

When AUTO is set during recording, the X-axis and Y-axis are automatically scaled so that all the time series graphs are displayed on the screen.

If you change the X/Y-axis scale, you can scroll through the time series graph in every direction.

6.6.3 IEC Flicker List

Statistics on Pst and Plt are displayed every 10 minutes, along with the date and time.

- Pst: short interval flicker value
- Plt: long interval flicker value

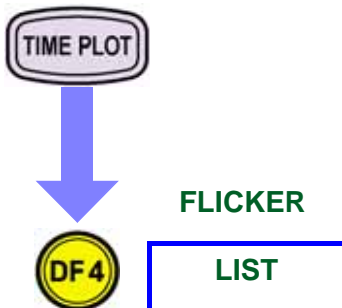

CH 1		CH 4		60Hz	INTERNAL MEMORY	STATUS		
1P2W	150V	50A	AC	150V	50A	PLL: U1	PC CARD MEMORY	SETTING
							RECORDING	
							ANALYZING	
No.	Date	Time	P s t	P l t				
1196	03-10	22:46:21	0.238	0.411	RMS			
1197	03-10	22:56:21	0.302	0.409	1 ELEMENT			
1198	03-10	23:06:21	0.337	0.413	2 ELEMENT			
1199	03-10	23:16:21	0.229	0.410	VOLTAGE			
1200	03-10	23:26:21	0.304	0.369	INTERVAL			
1201	03-10	23:36:21	0.331	0.369	EVENT			
1202	03-10	23:46:21	0.318	0.365	HARMONICS			
1203	03-10	23:56:21	0.356	0.370	HARM			
1204	03-11	00:06:21	0.620	0.386	INTERHARM			
1205	03-11	00:16:21	0.334	0.365	FLICKER			
							GRAPH	
							LIST	
CH1							2002/03/19	
							15:33:37	

NOTE

- The displayed statistics are for IEC flicker (Pst and Plt), and are displayed in the list every 10 minutes together with the date and time.
- This is only displayed if Pst, Plt is selected for flicker in **[SYSTEM]-DF2 [MAIN]-[MEASURE]**.
- EN50160, "Voltage characteristics of electricity supplied by public distribution systems", specifies a limit of $Plt \leq 1$ during 95% of a 1-week period.

6.6.4 ΔV_{10} Flicker Graph

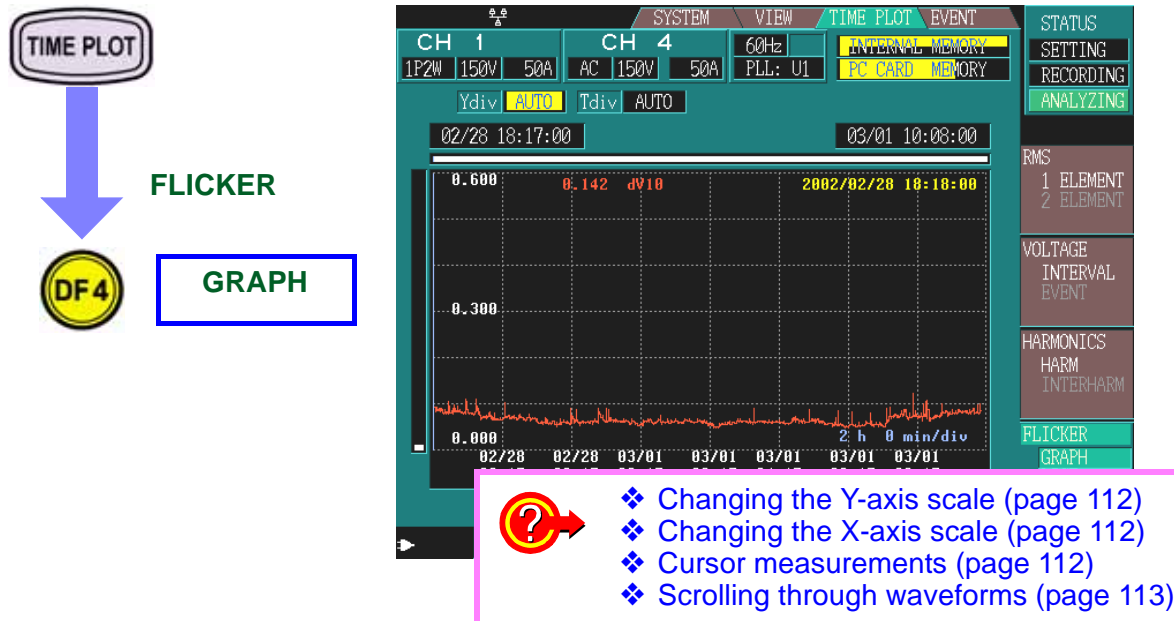

NOTE

- The graph is updated once a minute, regardless of the interval that is set for [SYSTEM]-DF2[MAIN]-[RECORDING].



- After you press , the clock displays "00" seconds and measurement starts.
- This is only displayed if ΔV_{10} is selected for flicker in [SYSTEM]-DF2[MAIN]-[MEASURE].
- ΔV_{10} flicker can only be measured on one of the voltage channels U1, U2, or U3.
- The measurement source is the same as the PLL source.

Reference voltage for ΔV_{10} flicker

With ΔV_{10} flicker measurement, the reference voltage is automatically set internally using AGC (automatic gain control). Once the fluctuating voltage value has stabilized, the reference voltage is automatically changed to that value.

Therefore, unlike conventional ΔV_{10} flicker meters, there is no need to switch supply voltage settings.

Example:

Fluctuating voltage: Stabilizes at 96 V rms reference voltage is automatically changed to 96 V rms

Fluctuating voltage: Stabilizes at 102 V rms reference voltage is automatically changed to 102 V rms

Due to the effect of the high pass filter used with ΔV_{10} flicker, if you begin measuring ΔV_{10} immediately after making settings, the ΔV_{10} flicker measurement value may be unstable, causing the first and second settings to display large values.

After making settings on the [SYSTEM] screen, it is recommended that you wait about 3 minutes before you start measuring.

Changing the Y-axis scale

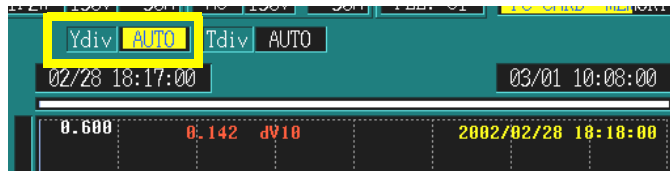
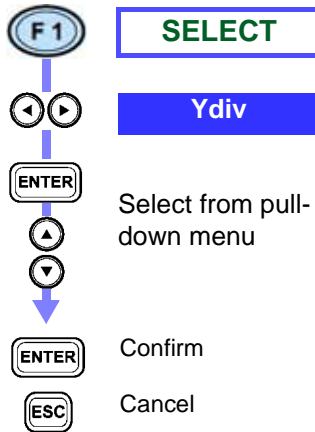

AUTO, x1, x2, x5, x10, x25, x50

When you want to reduce the graph, make the scale smaller.
When you want to enlarge the graph, make the scale larger.

AUTO scaling is used during recording.

Changing the X-axis scale

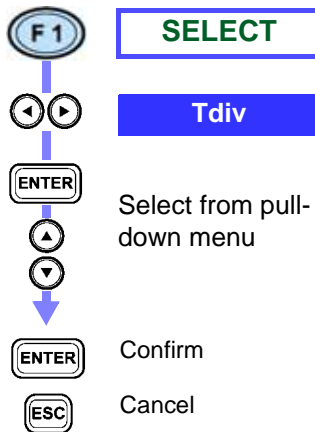

AUTO, x1, x1/2, x1/4, x1/8, x1/16, x1/32, x1/64

When you want to reduce the graph, make the scale smaller.
When you want to enlarge the graph, make the scale larger.

AUTO scaling is used during recording. This cannot be changed.

Cursor measurements

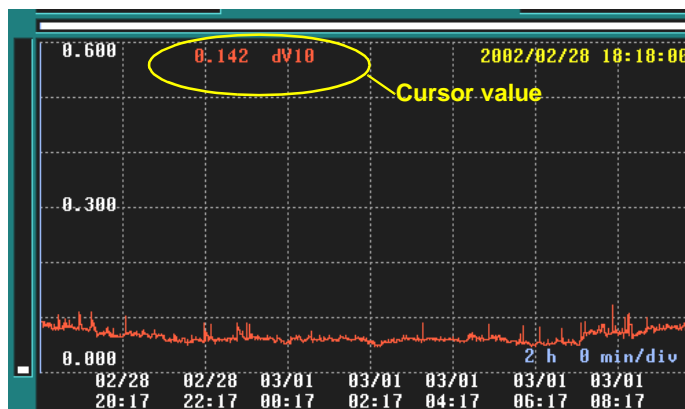
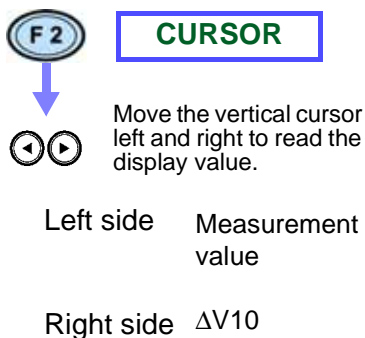

The measured value of ΔV_{10} flick can be read every 1 minute.

Scrolling through waveforms

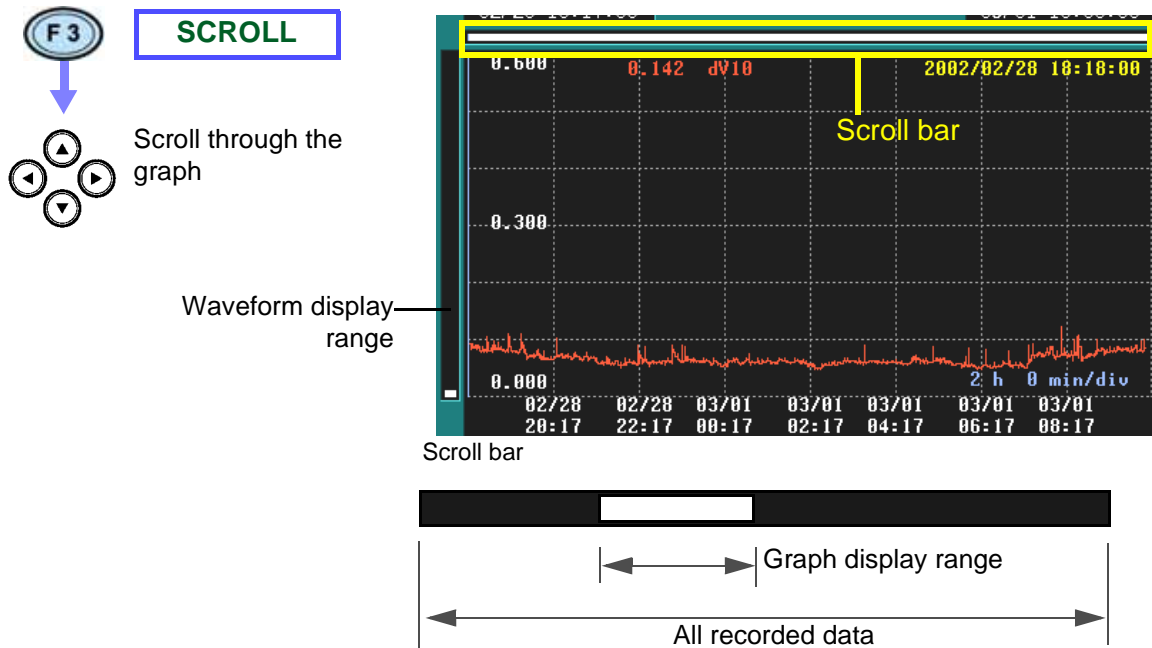

The waveform display range (white belt) on the scroll bar indicates what interval of recorded data is displayed on the screen.

When AUTO is set during recording, the X-axis and Y-axis are automatically scaled so that all the time series graphs are displayed on the screen.

If you change the X/Y-axis scale, you can scroll through the time series graph in every direction.

6.6.5 ΔV_{10} Flicker List

The following ΔV_{10} flicker statistics are updated every hour and displayed in the list together with the date and time.

- The maximum value over one hour for ΔV_{10} Flicker
- The fourth maximum value over one hour for ΔV_{10} Flicker
- The average value over one hour for ΔV_{10} Flicker

The ΔV_{10} flicker statistics are displayed for the measurement period. ΔV_{10} values are updated once a minute.

- Overall maximum value for ΔV_{10} Flicker

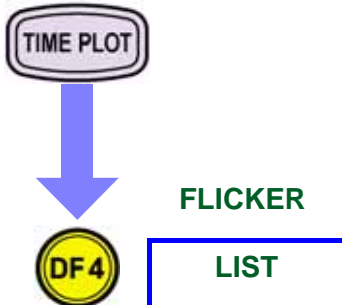

CH 1		CH 4		60Hz	INTERNAL MEMORY	STATUS
1P2W	150V	50A	AC	150V	50A	SETTING
				PLL: U1	PC CARD MEMORY	RECORDING
						ANALYZING
No.	Date	Time	ΔV_{10max} [V]	ΔV_{10max4} [V]	ave [V]	RMS 1 ELEMENT 2 ELEMENT VOLTAGE INTERVAL EVENT HARMONICS HARM INTERHARM FLICKER GRAPH LIST
1	10-12	19:40:00	0.127	0.096	0.081	
2	10-12	20:40:00	0.100	0.081	0.074	
3	10-12	21:40:00	0.092	0.081	0.073	
4	10-12	22:40:00	0.081	0.079	0.072	
5	10-12	23:40:00	0.080	0.073	0.068	
6	10-13	00:40:00	0.077	0.070	0.063	
7	10-13	01:40:00	0.069	0.063	0.056	
8	10-13	02:40:00	0.072	0.054	0.050	
9	10-13	03:40:00	0.076	0.052	0.049	
10	10-13	04:40:00	0.054	0.051	0.047	
TOTAL MAX			0.186 V			
CH1						2002/03/19 15:33:37

NOTE

- The statistics are updated once an hour, and the overall maximum value for ΔV_{10} flicker is updated once a minute.
- This is only displayed if ΔV_{10} is selected for flicker in [SYSTEM]-DF2 [MAIN]-[MEASURE].

Using Events

(EVENT Screen)

Chapter 7

1. Make event settings

❖ [Event Settings \(page 121\)](#)

By setting thresholds in advance, information regarding internal calculations that exceed the thresholds can be captured as events. Since thresholds are ordinarily set as the rated limits of the electrical facilities being used, the occurrence of an event can be interpreted as a power supply anomaly.

2. Check event thresholds

❖ [Event Monitor Display \(page 134\)](#)

You can check whether specified event thresholds are appropriate by looking at the event monitor screen. This is possible even without pressing the START key to start recording.

3. Perform measurements

Press  to record.

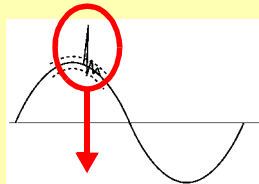

Event occurrence

As each event occurs, it is displayed on the EVENT screen.

4. Analyze events

❖ [Event List Display \(page 127\)](#)

❖ [Analyzing Event Occurrences \(page 130\)](#)

❖ [Analyzing Transient Waveforms \(page 131\)](#)

❖ [Event Monitor Display \(page 134\)](#)

Events displayed by the 3196

- Measurement start events
- Measurement stop events
- Calculation events (events for which thresholds can be specified)

NOTE

When measuring using events, be sure to enable event settings in the SYSTEM screen.



- ❖ [Event Settings \(page 121\)](#)

7.1 Using the EVENT Screen

Switching screen display

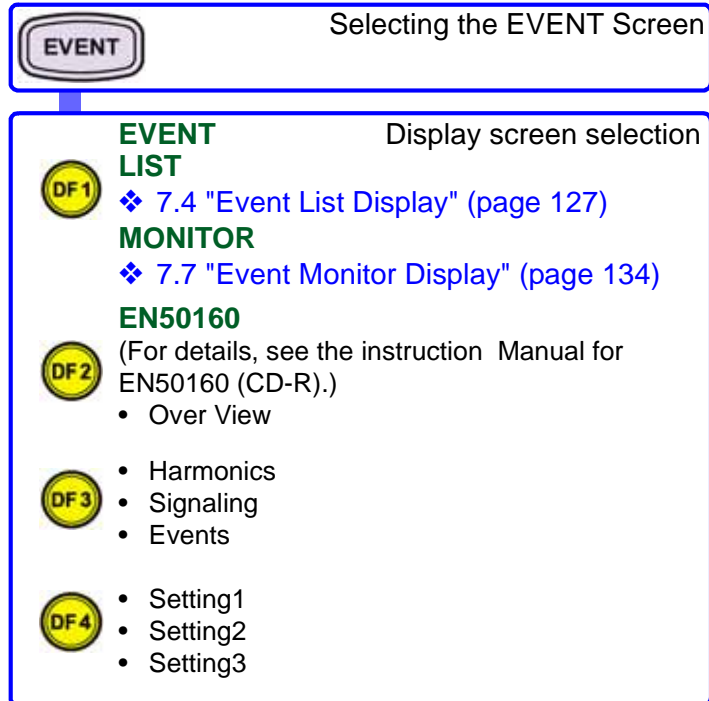

About screen configuration

- ❖ 2.2.2 "Screen Configurations"(page 19)
- ❖ 2.2.3 "Screen Details"(page 33 to 35)

The EVENT screen is made up of a number of screens that correspond to the **DF1** to **DF4** (DF: display function) keys.

When you press a DF key, the screen corresponding to that key appears. Each time you press the same DF key, the display changes.

Screen operations depending on the internal operation status



Screen operations are limited according to the internal operation status.

Status	Display update
[SETTING]	None
[RECORDING]	Each time an event occurs
[ANALYZING]	Stop

Can be used in the SETTING status only with the event monitor.

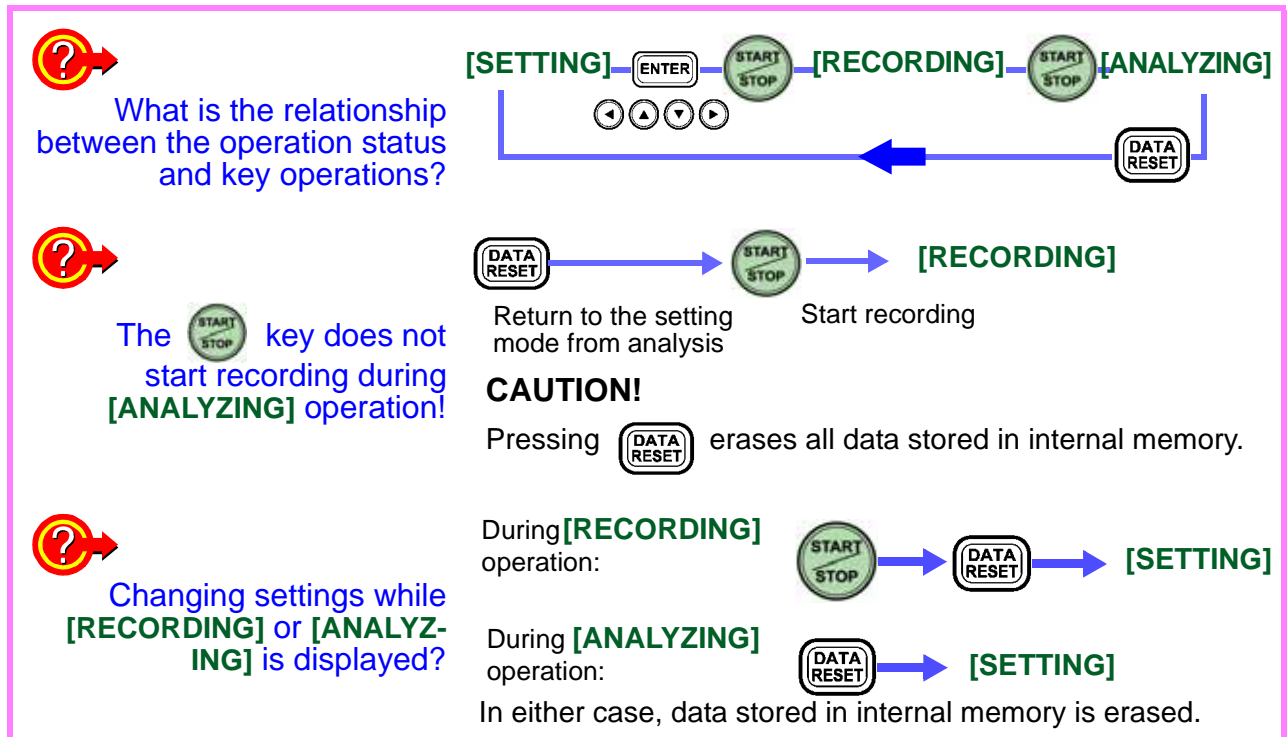

Memory status display



INTERNAL MEMORY: Internal memory
PC CARD MEMORY: ATA flash card

TIME PLOT related data capacity
 Measurement stops when memory becomes full.
 (Selectable Stop/Continuous)



Up to 100 EVENT data sets can be stored
 After 100 events are stored, the earliest are overwritten.

NOTE

While only 100 events can be recorded in internal memory, up to 1,000 events can be stored on a PC card.

7.2 Event Detection Method

Transient overvoltage

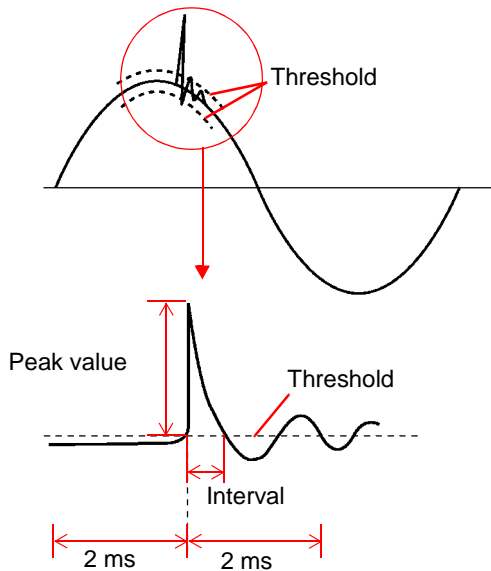

Detection method:

The voltage channels (U1 to U4) are sampled at 2 MHz and transients exceeding the absolute value of the threshold are detected.

Threshold determines the variance from the voltage waveform.

The waveform that is saved is the one that has the largest positive or negative transient peak.

Recorded contents:

1. Peak value:
Maximum absolute value (2000 Vmax)
2. Interval:
Period over which the threshold is exceeded (4 msmax)
3. Waveform:
Waveform centered around the peak value

Voltage swells, voltage dips, and interruptions

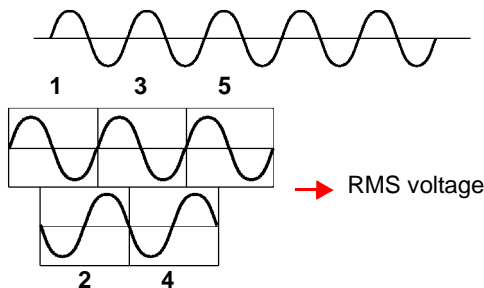

Swell

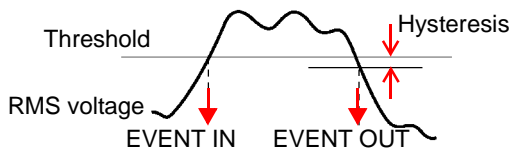

Dips and interruptions

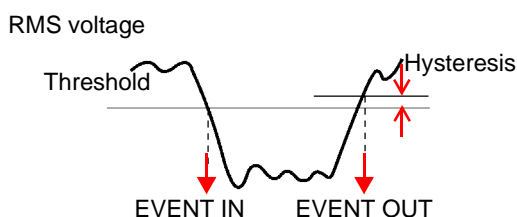

Detection method:

When measuring at 50 Hz or 60 Hz, events are detected using the RMS voltage of sampling data for a single wave (256 points) from a voltage waveform that is shifted by a half cycle.

When measuring at 400 Hz, events are detected using the RMS voltage of the sampling data for one full cycle (32 points).

Detection is based on the line-to-line voltage with three-phase three-wire connection, and on the phase-to-neutral voltage with three-phase four-wire connection.

Swell is detected when the RMS voltage RMS exceeds the threshold in the positive direction.

Dips and **interruptions** are detected when the RMS voltage exceeds the threshold in the negative direction.

(Hysteresis is applied for detection in both cases.)

Recorded contents:

1. Height, depth:
For swell, the threshold is the height, and is displayed as swell to %.
For dips, the threshold is the depth, and is displayed as dip to %.
For interruptions, the threshold is the depth, and is displayed as interruption to %.
2. Interval:
Period over which the threshold is exceeded

Frequency

Detection method:

Reciprocal detection (sampling at 2 MHz) with measurement and detection approximately every 200 ms (about once every 10 cycles at 50 Hz, every 12 cycles at 60 Hz, or every 80 cycles at 400 Hz)
The measurement source is U1, U2, or U3 (same as the PLL synchronization source)

Voltage waveform peaks, current waveform peaks, RMS voltage (upper limit, lower limit, SENSE), RMS current, active power, reactive power, apparent power, power factor, and displacement power factor

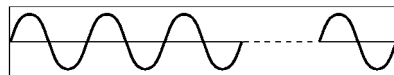

50 Hz: 10 cycles, 60 Hz: 12 cycles,
400 Hz: 80 cycles

RMS calculation

With RMS voltage (upper limit)

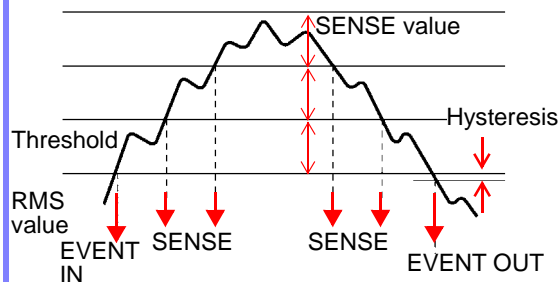

Detection method:

Measurement and detection at 256 points per cycle approximately every 200 ms (about once every 10 cycles at 50 Hz, every 12 cycles at 60 Hz, or every 80 cycles at 400 Hz)

With three-phase connection, the voltage calculation method (either phase-to-neutral voltage or line-to-line voltage) can be specified for **RMS voltage** detection.

Voltage waveform peaks, current waveform peaks, active power, reactive power, power factor, and displacement power factor are detected using thresholds specified as absolute values.

Voltage unbalance factor, current unbalance factor, harmonic voltage, harmonic current, harmonic power, harmonic voltage-current phase difference, total harmonic voltage distortion factor, total harmonic current distortion factor, and K factor

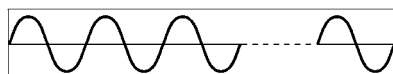

50 Hz: 10 cycles, 60 Hz: 12 cycles,
400 Hz: 80 cycles

Harmonic calculation in a rectangular window

With 3rd order harmonic voltage

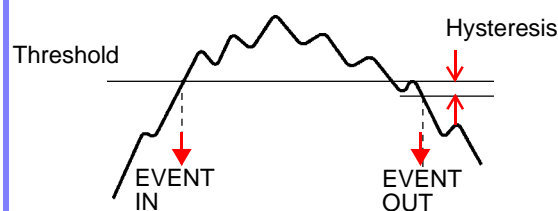

Detection method:

Measurement and detection are performed in a 2048-point rectangular window containing 10 cycles at 50 Hz, 12 cycles at 60 Hz, or 80 cycles at 400 Hz. Thresholds can be specified individually for each harmonic order for **harmonic voltage, harmonic current, harmonic power, and harmonic voltage current phase difference**.

For **harmonic voltage, harmonic current, and harmonic power**, detection can be performed using either of two selectable harmonic calculation methods (effective value or content percentage).

For **total harmonic voltage distortion factor** and **total harmonic current distortion factor**, detection can be performed using either of two selectable THD calculation methods (RMS based or fundamental wave based).

Harmonic power and **harmonic voltage current phase difference** are detected using thresholds specified as absolute values.

Harmonic voltage distortion

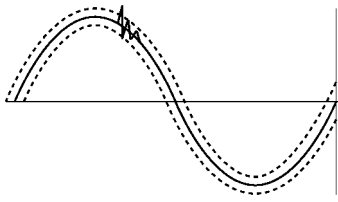

Reference waveforms are formed above and below the voltage waveform with an interval of 200 ms and with an offset equivalent to the threshold value, then detection is performed by comparing the measured waveform with these reference values.

External event

External events are detected either when the external control terminal (EVENT IN) is shorted, or at the falling edge of the input pulse signal.

Voltage and current waveforms can be recorded along with measured values upon occurrence of external events.

❖ (See Chapter 8.)

Manual event

Manual events are detected when **ESC** and **EVENT** are pressed simultaneously.

Voltage and current waveforms can be recorded along with measured values upon occurrence of manual events.

Activates when the external event is set to ON.

❖ For details on the Event waveform recording method: Event Waveform Recording Method (page 216)

Timer event

A trigger event occurs after each specified interval, and is recorded as an external event.

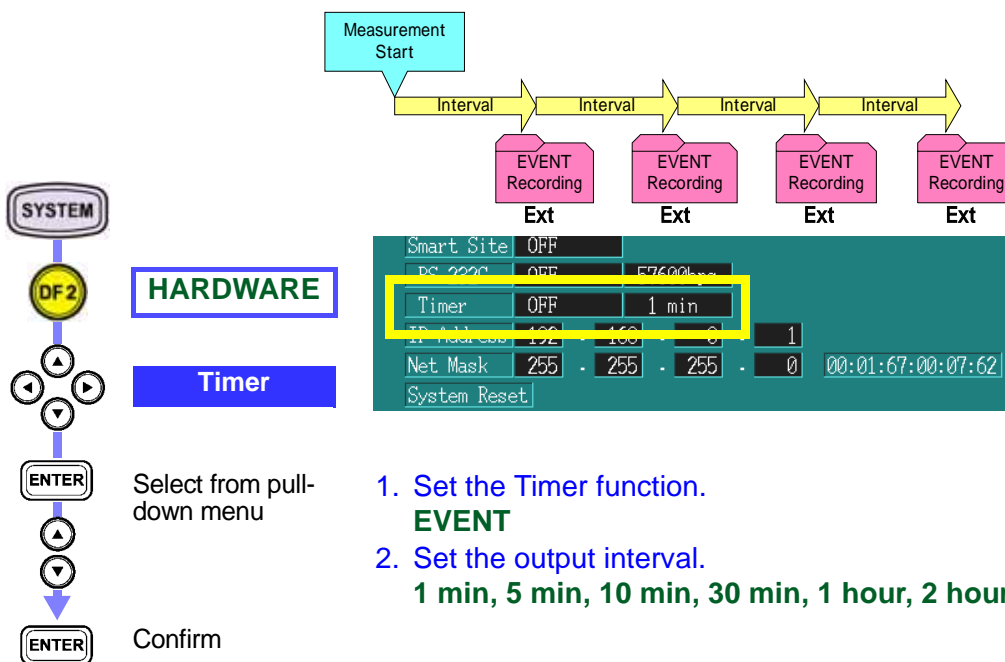

Upon starting measurement, timer events are recorded at the predetermined intervals (output interval setting) from the start time.

When the event timer is selected, external event setting is forced ON.

7.3 Event Settings

Events and thresholds are set in the SYSTEM screen.

- ❖ Voltage/Power Event Settings (page 122)
- ❖ Harmonics Event Setting (page 126)

Item	Order selection*2	Measurement selection*3	Positive and negative*4	Channel selection*5			Threshold*1
				PLL source	-	OFF	
Voltage frequency			Approximately	PLL source	-	OFF	0 to 30 Hz
Voltage waveform comparison*6				1,2,3	-	OFF	0 to 100%
External event*7				External	-	OFF	None
Voltage transient			±	1,2,3,4	-	OFF	0 to 2000 Vpk
Voltage swell				1,2,3	-	OFF	Threshold: 0 to 200%
Voltage dip				1,2,3	-	OFF	Threshold: 0 to 100%
Voltage interruption				1,2,3	-	OFF	Threshold: 0 to 100%
RMS voltage value	Upper limit/ Lower limit	Phase-to-n/ line-to-line		1,2,3	4	OFF	0 to 600 Vrms
RMS voltage (SENSE)		Phase-to-n/ line-to-line		1,2,3	4	OFF	0 to 60 Vrms
RMS current				1,2,3	4	OFF	0 to 500 A
Voltage waveform peak (±)			±	1,2,3	4	OFF	0 to 1.8 kV
Current waveform peak (±)			±	1,2,3	4	OFF	0 to 2.0 kA
Active power			±	1,2,3	sum	OFF	0 to 3 MW
Reactive power			±	1,2,3	sum	OFF	0 to 3 Mvar
Apparent power				1,2,3	sum	OFF	0 to 3 MVA
Power factor/Displacement power factor		PF/DPF	±	1,2,3	sum	OFF	0 to 1
K factor				1,2,3	4	OFF	0 to 500%
Total harmonic voltage distortion factor		-F/-R		1,2,3	4	OFF	0 to 500%
Total harmonic current distortion factor		-F/-R		1,2,3	4	OFF	0 to 500%
Voltage unbalance factor				-	sum	OFF	0 to 100%
Current unbalance factor				-	sum	OFF	0 to 100%
Harmonic voltage	1st to 50th orders*8	RMS/%		1,2,3	4	OFF	0 to 600 Vrms/0 to 100%
Harmonic current	1st to 50th orders*8	RMS/%		1,2,3	4	OFF	0 to 5 kA/0 to 100%
Harmonic power	1st to 50th orders*8	RMS/%	±	1,2,3	sum	OFF	0 to 3 MW/0 to 100%
Harmonic voltage-current phase difference	1st to 50th orders*8		±	1,2,3	sum	OFF	0 to 180

*1: The recorded threshold is the multiplication result when the PT ratio and CT ratio are set.

*2: For harmonics, settings can be made individually for each harmonic order.

*3: Measurement settings can be selected for each type of measurement (inter-phase or line-to-line and -F or -R).

*4: Plus and minus (±) indicates that the threshold is specified as an absolute value.(Events are detected using absolute values regardless of whether they are positive or negative.)

*5: You can set the thresholds individually for channels that are separate and not off.

*6: Hysteresis is selected as a percentage value common to all thresholds in the range 0 to 10%. Frequency hysteresis is fixed at 0.1 Hz.

*7: External events can be signals at any external event terminal, manual events or timer events.

*8: Harmonic voltage, current, power and harmonic voltage-current phase difference are available up to the 10th order during 400 Hz measurements.

7.3.1 Voltage/Power Event Settings

Make the following settings in the SYSTEM screen.

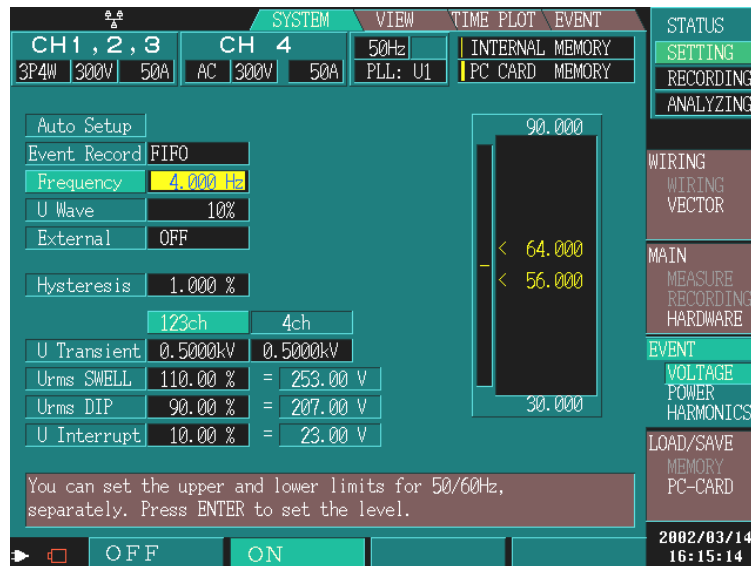
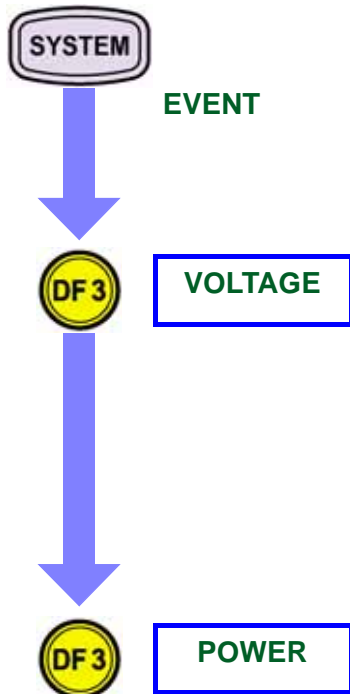

- ❖ Automatic setting of event thresholds (page 123)
- ❖ Turning off all event thresholds (page 123)
- ❖ Setting the event recording sequence (page 124)
- ❖ Event ON/OFF settings (page 124)
- ❖ Setting of event thresholds (page 125)
- ❖ Setting of event thresholds (voltage waveform comparison) (page 125)

Automatic setting of event thresholds

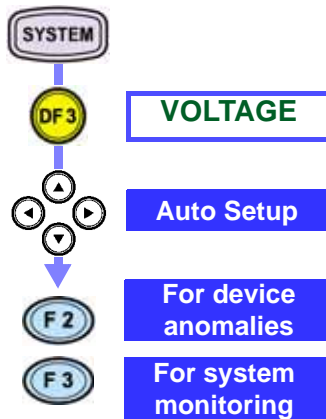

Auto Setup	
Event Record FIFO	
Frequency	2.000 Hz
U Wave	5%
External	ON

Event thresholds (voltage, power, and harmonic) are set automatically, taking the current measurement as the normal value.

It is recommended that thresholds be individually adjusted, using the thresholds set automatically for reference.

NOTE

The thresholds set will be meaningless if automatic setting is used when no input is present.

See the Appendix for parameters and levels that are automatically set with automatic event setting.

❖ [Contents of Automatic Setting of Events \(thresholds\) \(page 228\)](#)

Turning off all event thresholds

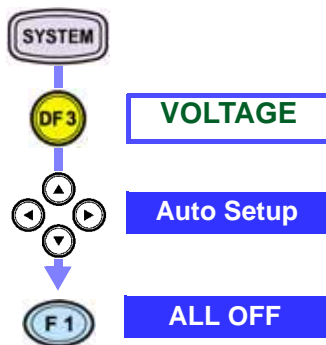

Auto Setup	
Event Record FIFO	
Frequency	2.000 Hz
U Wave	5%
External	ON

All event thresholds for voltage, power, and harmonics are turned OFF.

Setting the event recording sequence

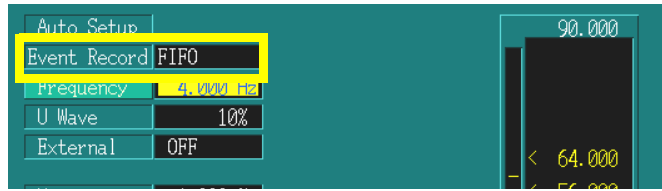
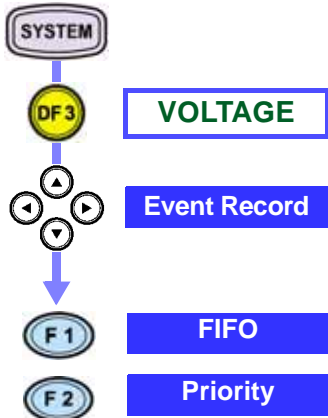

Set the order in which events (voltage, power, and harmonic) are displayed in the event list screen.

FIFO (Time order) Events are listed in the order in which they occurred.

Priority (Priority order) Events are listed in worst-case order (according to severity).

NOTE

The event recording sequence cannot be changed during post-measurement analysis.

The order of event priority cannot be changed.

See the Appendix regarding the internal setting of the event priority order.

❖ [Event Recording Sequence \(Priority Order\) \(page 230\)](#)

Event ON/OFF settings

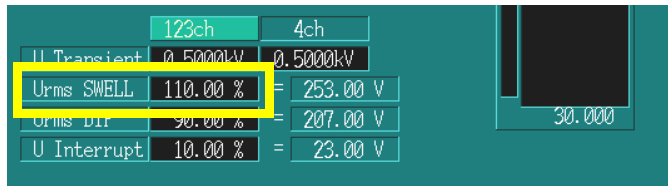
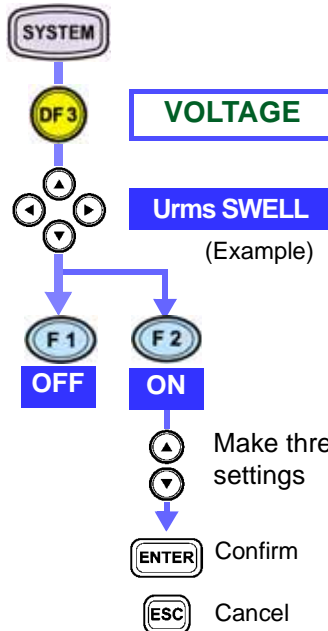

OFF Disables voltage swell event functions

ON Enables voltage swell event functions
Make threshold settings

NOTE

The thresholds for voltage swell, voltage dip, and voltage interruption are set as percentages of the nominal voltage.

❖ [Nominal voltage settings \(page 52\)](#)

Voltage equivalents of percentage values are displayed on the right side.

Setting of event thresholds

SYSTEM

DF3

VOLTAGE

Frequency

Frequency

(Example)

F2

ON

Make threshold settings

Make threshold settings

ENTER

Confirm

ESC

Cancel

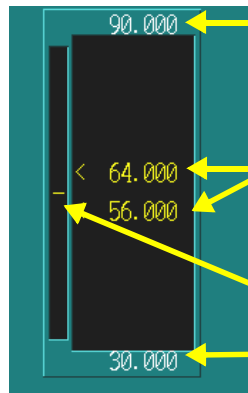

Upper settable threshold limit

Currently set threshold

Current measurement value

Lower settable threshold limit

Thresholds can be set while viewing the current measurement values.

Events set are stored internally regardless of the event ON/OFF setting.
Event triggers are not effective until the event setting is set to ON.

Setting of event thresholds (voltage waveform comparison)

SYSTEM

DF3

VOLTAGE

U wave

U wave

(waveform comparison)

ENTER

Make threshold settings

Make threshold settings

ENTER

Confirm

ESC

Cancel

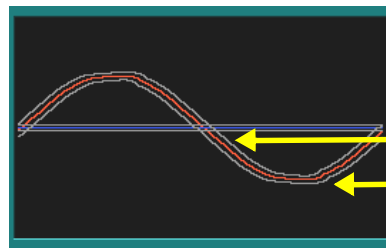

Waveform currently being measured

Upper side of waveform envelope level

Lower side of waveform envelope level

When the measured waveform exceeds the waveform envelope level, a voltage waveform comparison event is generated.

Events set are stored internally regardless of the event ON/OFF setting.
Event triggers are not effective until the event setting is set to ON.

7.3.2 Harmonics Event Setting

Make the following settings in the SYSTEM screen.

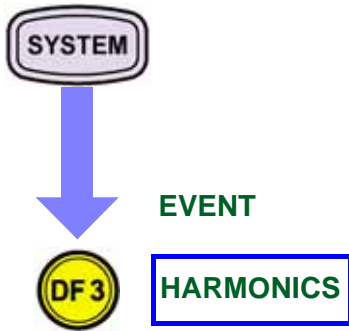

The screenshot shows the 'SYSTEM' screen with the following settings:

	123ch	4ch
U Harmonics	ON : 5	ON : 0
I Harmonics	ON : 0	ON : 0
P Harmonics	ON : 0	ON : 0
Angle	ON : 0	ON : 0

Below the table is a graph showing voltage levels over time. A callout box with a question mark icon contains the text: 'Event ON/OFF settings and threshold settings (page 126)'.

Event ON/OFF settings and threshold settings

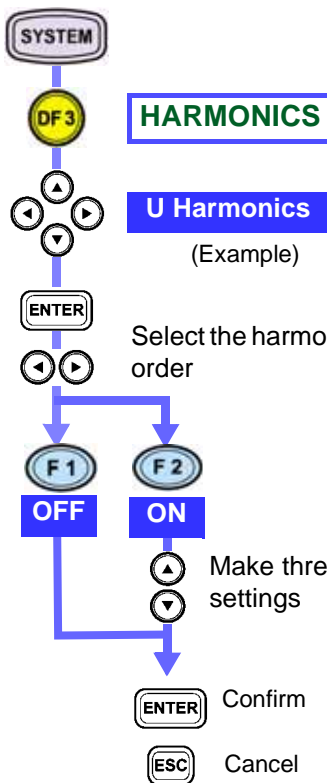

	123ch	4ch
U Harmonics	ON : 5	ON : 0
I Harmonics	ON : 0	ON : 0
P Harmonics	ON : 0	ON : 0
Angle	ON : 0	ON : 0

Set ON or OFF for each harmonic order.
 (ON: numeric value)
 The numeric value indicates the total number of harmonic orders set to ON.

- OFF** Disables voltage harmonic event functions
- ON** Enables voltage harmonic event functions

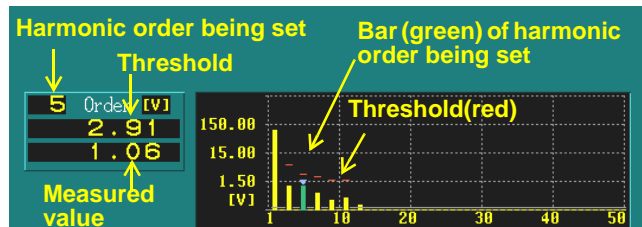

Events set are stored internally regardless of the event ON/OFF setting.
 Event triggers are not effective until the event setting is set to ON.

7.4 Event List Display

Displays events in a list.

The diagram illustrates the navigation path from the **EVENT** menu to the **DF1** menu, which then displays the **LIST** screen. The **LIST** screen shows a table of event data with columns for No., Date, Time, Event, and Category. A yellow box highlights the event details for event 4.

No.	Date	Time	Event	Category
2	11-09	15:42:34.196	Wave	CH1
3	11-09	15:42:33.994	U_THD	CH1 OUT
4	11-09	15:42:33.844	Inter	CH1 OUT
5	11-09	15:42:29.194	U_THD	CH1 IN
6	11-09	15:42:29.127	Dip	CH1 IN
7	11-09	15:42:16.187	U_THD	CH1 OUT
8	11-09	15:42:15.987	Wave	CH1
9	11-09	15:42:15.787	U_THD	CH1 IN
10	11-09	15:42:15.754	Dip	CH1 IN
11	11-09	15:42:06.183	Start	

Annotations:

- ❖ Correspondence between event settings and event category display (page 128)
- ❖ Displaying events (page 127)
- ❖ Scrolling through the event list (page 128)
- ❖ Scrolls the event details list. (page 128)

Information that is recorded as the event includes the start time, stop time, the 3196 message, and event parameters set in the SYSTEM screen.

A total of 100 events can be recorded.

If different multi-parameter events occur within the same 200 ms span, they are grouped and displayed together as one event.

The contents of the multi-parameter events are displayed in the lower part of the screen.



Changing the list display sequence

❖ Setting the event recording sequence (page 124)

The display sequence cannot be changed while the status is **[RECORDING]** or **[ANALYZING]**.

Change the display sequence while in the **[SETTING]** status.

Displaying events



LIST



Select an event



Confirm

No.	Date	Time	Event	Category
2	11-09	15:42:34.196	Wave	CH1
3	11-09	15:42:33.994	U_THD	CH1 OUT
4	11-09	15:42:33.844	Inter	CH1 OUT
5	11-09	15:42:29.194	U_THD	CH1 IN
6	11-09	15:42:29.127	Dip	CH1 IN
7	11-09	15:42:16.187	U_THD	CH1 OUT

You can select an event and display detailed event information and the contents of multi-parameter events.

Scrolling through the event list



Scrolls the event list up or down.

Scrolls the event details list.



Scroll the event details list up or down.

```

2001/11/9 15:42:33.860 Dip CH1 OUT 0.08 V 0:00:04.733
2001/11/9 15:42:33.844 Inrupt CH1 OUT 0.08 V 0:00:04.70
2001/11/9 15:42:33.844 Wave CH1
2001/11/9 15:42:33.860 Wave CH1
  
```

See the specifications for details.

❖ [Measurements \(page 183\)](#)

Correspondence between event settings and event category display

Event setting		Event category	
Others	Start	Start	
	Stop	Stop	
Voltage	Frequency	Freq	
	Voltage waveform comparison	Wave	
	External event, manual event	Ext	
	Voltage transient	Tran	
	Voltage swell	Swell	
	Voltage dip	Dip	
	Voltage interruption	Inter	
	Power	Voltage RMS upper limit	Urms
Voltage RMS lower limit		Urms	
Current RMS value		Irms	
Voltage waveform peak		U peak+	U peak-
Current waveform peak		I peak+	I peak-
Active power		P	
Reactive power		Q	
Apparent power		S	
Power factor		PF	
K factor		KF	
Voltage distortion factor		U_THD	
Current distortion factor		I_THD	
Voltage unbalance factor		U_UNB	
Current unbalance factor		I_UNB	
Harmonic	Voltage harmonic	U_HARM	
	Current harmonic	I_HARM	
	Power harmonic	P_HARM	
	Harmonic phase difference	PHASE	

For details on events displayed in the last column of the event list, see Text Event Data-format Composition (page 227)

About the event list sequence

Time order

Example: When 35 events have occurred

No.1 Dip CH1 OUT Indicates the event that occurred last.
(Events ended with occurrence of a voltage dip.

No.35 Start Indicates the event that occurred first. (Start event occurred.

Priority order

Example: When 100 or more events have occurred

No.1 Dip CH1 OUT Indicates the highest priority. (Events ended with occurrence of a voltage dip.

No.100 Wave CH1 Indicates an event with low priority. (Voltage waveform distortion occurred.

About the event list display contents

List display

Example: 96 06-16 12:47:58:253 U_THD CH1 IN

96 Sequence number

06-16 Month - Day

12:47:58:253 Hour:minute:second:1/1000th sec

U_THD Total voltage distortion factor.

CH1 Channel 1

IN Measurement start and end times

Details display

Example: 2001/6/16 12:48:06.845 Swell CH1 OUT 108.52V 0:00:04.642

2001/6/16 Year/Month/Day

12:48:06.845 Hour:minute:second:1/1000th sec

Swell Voltage swell

CH1 Channel 1

OUT End of occurrence

108.52V The worst value

0:00:04.642 Time from start of occurrence to end of occurrence

7.5 Analyzing Event Occurrences

Analyzing event occurrences

EVENT

DF1

LIST

Select an event

ENTER

Confirm

ESC

Return to event list

3	08-04	15:45:05.600	Dip	CH1 IN
4	07-23	18:15:49.383	Dip	CH1 OUT
5	07-23	18:15:49.274	Dip	CH1 IN
6	07-17	06:30:48.744	Dip	CH1 OUT
7	07-17	06:30:48.627	Dip	CH1 IN
8	07-09	18:28:22.068	Start	

2002/8/4	19:07:17.631	Dip	CH1 IN	90.00%
2002/8/4	19:07:17.747	Dip	CH1 OUT	56.75 V 0:00:00.116
2002/8/4	19:07:17.631	Dip	CH2 IN	90.00%
2002/8/4	19:07:17.747	Dip	CH2 OUT	56.84 V 0:00:00.116

Event details

Select an event to display a corresponding waveform analysis.

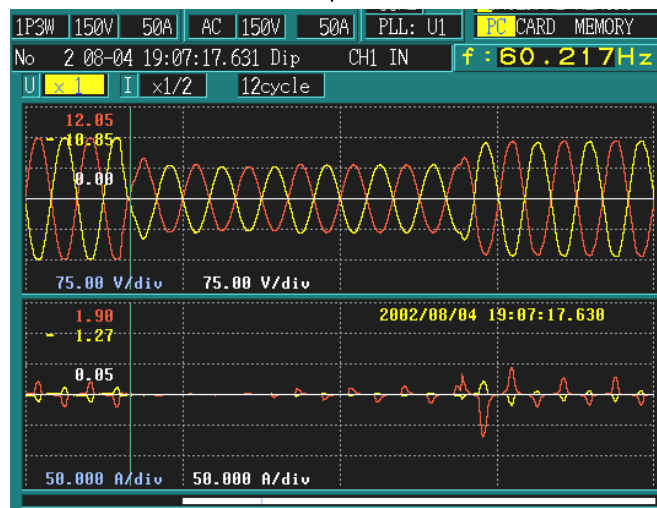

NOTE

From the event details screen (the event waveform screen), you can switch to the other screens related to event occurrence (**DF1[WAVE]**, **DF2[VECTOR]**, **DF3[DMM]**, and **DF4[HARMONICS]**) by pressing the DF key.

- ❖ For details on the Event waveform recording method; Event Waveform Recording Method (page 216)

7.6 Analyzing Transient Waveforms

Displaying transients

EVENT

DF1

LIST

No.	Date	Time	Event Category
1	06-24	13:46:58.099	Stop
2	06-24	13:46:50.553	Tran CH1 IN
3	06-24	13:46:06.250	Tran CH1 IN
4	06-24	13:45:21.047	Tran CH1 IN
5	06-24	13:44:31.929	Tran CH1 IN
6	06-24	13:43:47.194	Start

Select an event category from the event list or an event indicated with "Tran" in the detailed event list.

ENTER

Confirm
(Display changes to the VIEW screen waveform display.)

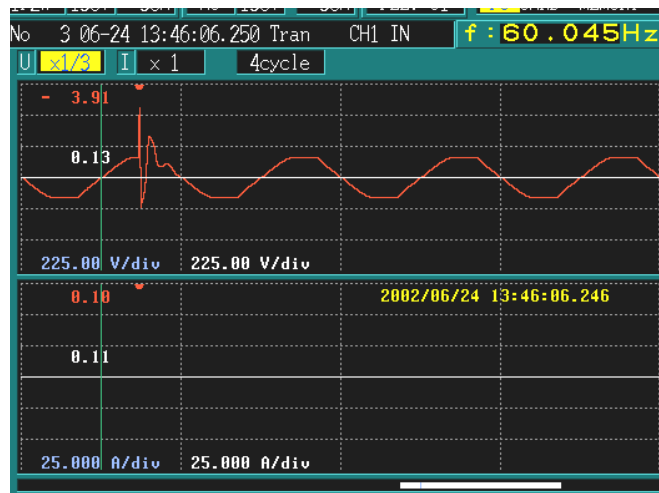

F4

TRANSIENT

Voltage waveform

Transient waveform

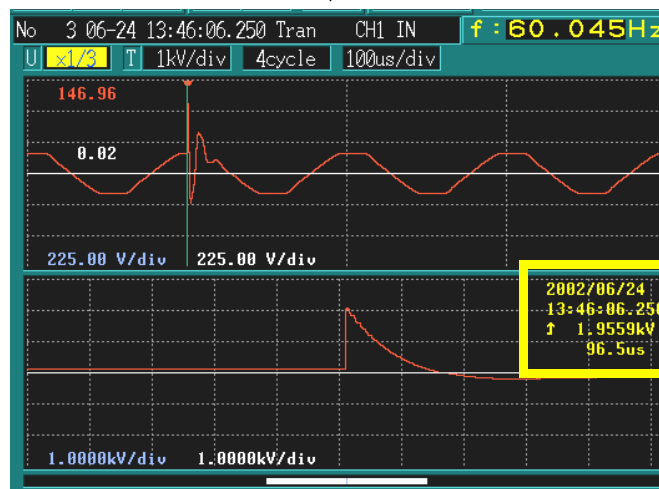

Transient data
year/month/
day, time,
rising edge,
peak value,
duration

Display switches between the voltage/current waveform display and the voltage/transient waveform display each time you press **F4**.

ESC

Return to event list

Enlarging transient waveforms Changing the Y-axis range of waveforms

F1

SELECT

← →

T

ENTER

Select from pull-down menu

↑

↓

ENTER

Confirm

ESC

Cancel

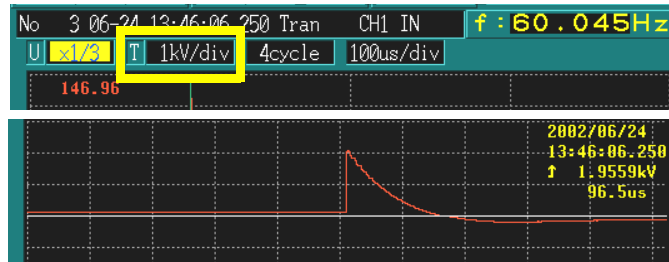

1kV/div, 600V/div, 300V/div, 150V/div, 60V/div, 30V/div

To reduce the waveform, make the voltage value larger.
To enlarge the waveform, make the voltage value smaller.

Changing the X-axis range of waveforms

F1

SELECT

← →

50 μ s/div

ENTER

Select from pull-down menu

↑

↓

ENTER

Confirm

ESC

Cancel

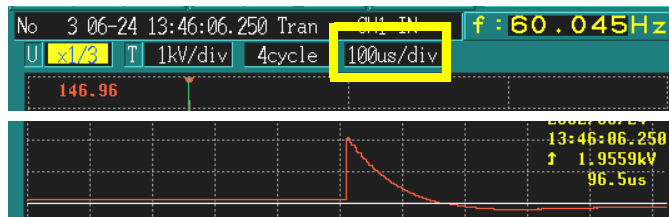

25 μ s/div, 50 μ s/div, 100 μ s/div, 200 μ s/div, 400 μ s/div

To reduce the waveform, make the X-axis range value smaller.
To enlarge the waveform, make the X-axis range value larger.

Searching for transients

F2

TRANS SEARCH

(Search for transients)

← →

Select transient from voltage waveform

ESC

Return to event list

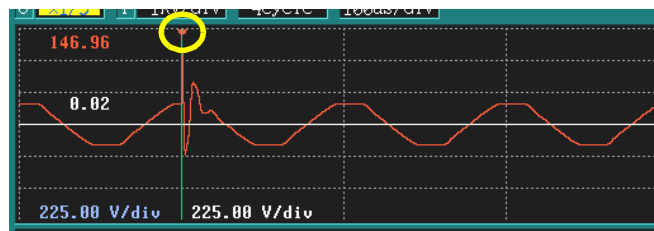

If the voltage waveform contains multiple transients, you can select one of them.

Scrolling through transient waveforms

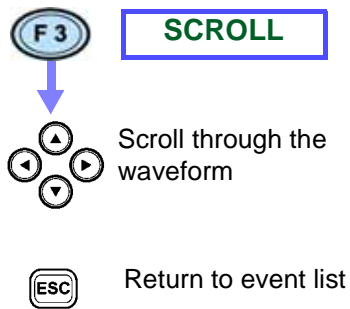

Scroll bar

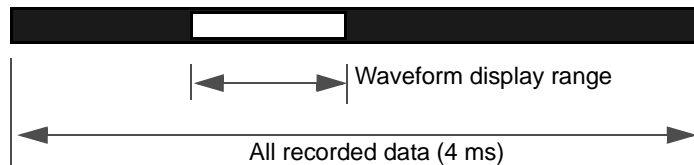

The waveform display range (white belt) on the scroll bar indicates what interval of recorded data is displayed on the screen.

When you scroll horizontally, you can check all the saved waveform.

When you scroll vertically, you can change the offset position of the displayed waveform.

7.7 Event Monitor Display

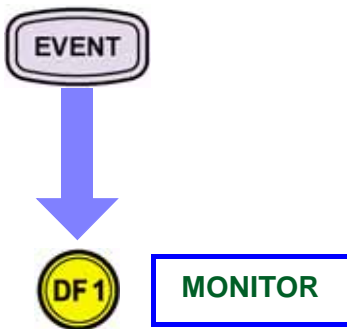

You can monitor all events to determine whether and how many occurred.

If there are no events, 0 is displayed

If there are events, they are indicated in when and a count shows the number of occurrences.

Voltage fluctuation event

Transient Swell	Transient overvoltage
Dip	Voltage swell (rise in RMS voltage)
Interruption	Voltage dip (drop in RMS voltage)
Waveform:	Interruption (voltage interruption)
	Voltage waveform comparison

Other events

External	Start, stop, external event, manual event
----------	---

Basic RMS event

Frequency	Frequency
Voltage	RMS voltage, voltage waveform peak
Current	RMS current, current waveform peak
Power	Active power, reactive power, apparent power
Power factor	Power factor (or displacement power factor)
Unbalance	Voltage unbalance factor, current unbalance factor

Harmonic event

Voltage	Voltage harmonic
Current	Current harmonic
Power	Power harmonic, harmonic phase difference
Voltage distortion	Voltage THD-F (or voltage THD-R)
Current distortion	Current THD-F (or current THD-R)
KF	K factor

NOTE

- You can use this function even when the internal operation status is **[SETTING]**. Threshold settings can be changed and you can check for occurrence of events in the event monitor by making event settings with **[SYSTEM]-DF3[EVENT]**.
- When recording is started and the internal operation status changes to **[RECORDING]**, event monitoring starts after first clearing all events displayed.
- When recording is started, the start event occurs and External in Other Events always changes to 1. Similarly, when recording is stopped, the stop event occurs and External in Other Events always changes to 2.

Using the External Control Terminals

Chapter 8

You can enter events and output event occurrence times with the external control terminals.

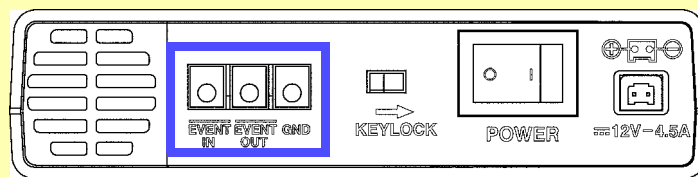

EVENT IN GND

Anomaly search device

Event input terminal (EVENT IN)

Synchronized with an external device, analyzes anomalies. When you connect the search signal of an anomaly search device such as an overcurrent relay to the event input terminal, you can analyze anomalies using this device according to anomaly operations.

- ❖ 8.2 "Event Input Terminal (EVENT IN)" (page 137)

EVENT OUT GND

Trigger input terminal

HIOKI MEMORY HiCORDER

Event output terminal (EVENT OUT)

This informs an external device when anomalies occur within the 3196. When you connect the event output terminal to a trigger input terminal on a waveform recording device such as the HIOKI MEMORY HiCORDER, you can record waveforms on the MEMORY HiCORDER when events occur.

- ❖ 8.3 "Event Output Terminal (EVENT OUT)" (page 138)

CAUTION

To avoid damaging this device, do not input voltages outside the ranges -5 V to +10 V (EVENT IN) or 0 to +50 V (EVENT OUT) to the external control terminals.

NOTE

When using the external control terminals, to use the external event function, set the external event to **ON**.



8.1 Connecting to the External Control Terminal



To avoid electric shocks, use the specified material only.

Connecting to the external control terminals



Electric wires that conform with:

single line $\phi 1.0$ mm (AWG 18) or twisted line 0.75 mm²

Supported electric wires:

single wire $\phi 0.4$ to 1.0 mm (AWG 26 to 18)

twisted wire 0.3 to 0.75 mm² (AWG 22 to 20)

diameter of search wire: more than $\phi 0.18$ mm

Standard direction wire length: 10 mm

Tools that conform to button operations:

flat head screwdriver (width of blade-tip: 2.6 mm)

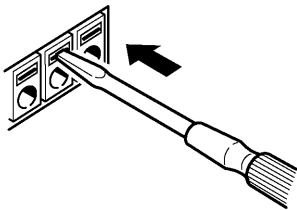

1. Press down on the terminal button using a tool, such as a flat head screwdriver.

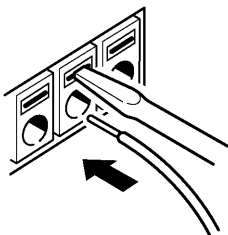

2. While the button is depressed, insert the wire into the electric wire connection hole.

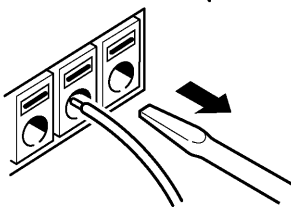

3. Release the button.

The electric wire is locked in place.

8.2 Event Input Terminal (EVENT IN)

By inputting a signal to the event input terminal externally, you can make the 3196 determine that an external event has occurred when that event was input. Similar to other events, you can record the voltage and current waveforms, and the measurement values of external events.

Using this device, you can analyze power anomalies that occur in other electrical equipment.



To avoid damaging this device, do not input voltages outside the range -5 V to +10 V to the external control terminals.

Signal input methods

Short-circuit the terminal or input a pulse signal.

Use the event input terminal (EVENT IN) and the ground terminal (GND).

You can control the event input terminal by short-circuiting the terminal (active LOW) or dropping the pulse signal (2.5 V).

Input voltage range	HIGH level: 3.0 to 5.0 V LOW level: 0 to 1.0 V
Maximum input voltage	-5 to 10 V

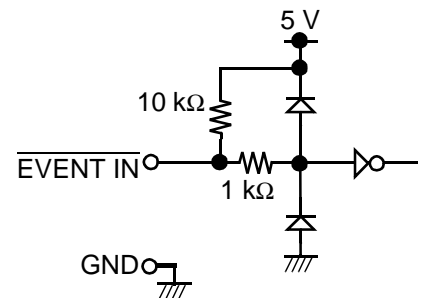
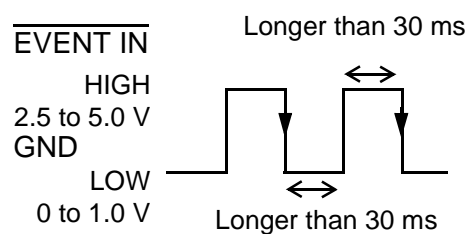

8.3 Event Output Terminal ($\overline{\text{EVENT OUT}}$)

This indicates events occurring externally that were synchronized with events occurring internally for this device.

Usage method 1.

Connect a warning device.

This is a good way to output warnings when events such as interruptions occur.

Usage method 2.

Connect to the trigger input terminal of a MEMORY HiCORDER.

This allows you to record waveforms on the MEMORY HiCORDER when events occur on the 3196.

You can record between 14 and 16 waveforms on the 3196 when events occur. When you want to record waveforms for a longer period of time, use the 3196 in parallel with a MEMORY HiCORDER.



To avoid damaging this device, do not input voltages outside the 0 V to +50 V range to the external control terminal.

Signal output method

If an event occurs in the 3196, a pulse signal is output.

Use the event output terminal ($\overline{\text{EVENT OUT}}$) and the ground terminal (GND).

Output signal	Open collector output (includes voltage output) Active LOW
Output voltage range	HIGH level: 4.5 to 5.0 V LOW level: 0 to 0.5 V
Pulse width	LOW level: longer than 10 ms
Maximum input voltage	0 to 50 V, max. 50 mA, 200 mW

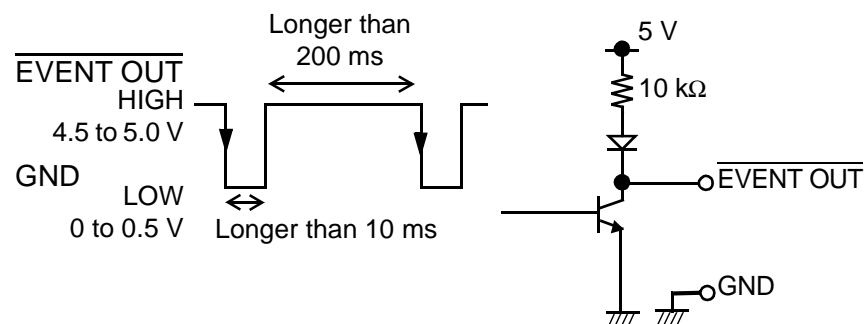

8.3 Event Output Terminal (EVENT OUT)

Event output can be set for Smart Site.

The screenshot shows the 'SYSTEM' menu with various settings. The 'Smart Site' option is currently set to 'OFF' and is highlighted with a yellow box. The menu also displays system information such as 'Version Ver 1.40', 'Language English', and 'Clock 2005 Y 9 M 2 D 11 h 0 m 4 s'. On the right side, there are several menu categories like 'STATUS', 'SETTING', 'RECORDING', 'ANALYZING', 'WIRING', 'WIRING VECTOR', 'MAIN', 'MEASURE', 'RECORDING', 'HARDWARE', 'EVENT', 'VOLTAGE', 'POWER', 'HARMONICS', 'LOAD/SAVE', 'MEMORY', 'PC-CARD', and a date/time display '2005/09/02 11:00:10'.

Set Smart Site to ON.
ON

NOTE

- When the START event occurs, no pulse signal (Low pulse) is output from the event output terminal.
 - The pulse signal from the event output terminal is held Low for about 1.5 seconds.
- When events occur continuously (but for not more than 1.5 seconds each), the signal goes Low at the first event, and remains Low until about 1.5 seconds after the last event occurs (see diagram below).

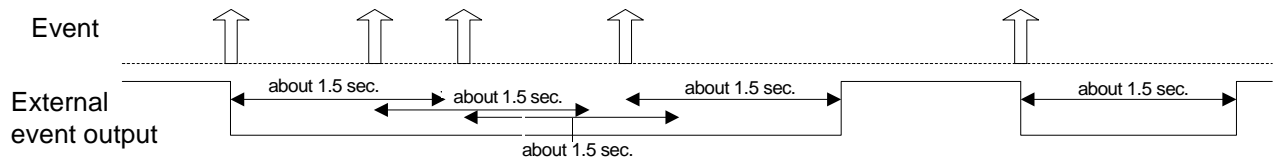

Loading and Saving Settings and Measured Data

Chapter 9

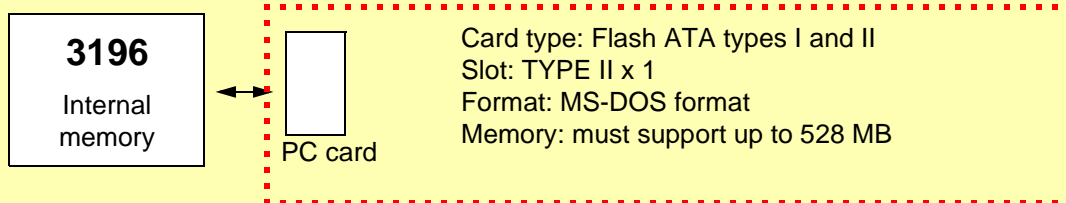

●: Possible/ ×: Not possible

Saving and loading data	Using the internal memory ❖ (page 142)	Using a PC card ❖ (page 143)
Saving setting conditions	● (up to 10 files)	●
Loading setting conditions	●	●
Saving measured data	×	● (binary format/text format)
Loading measured data	×	● (binary format only)
Saving screen data	×	● (BMP files)

The PC card interface installed in this device conforms to PCMCIA (Personal Computer Memory Card International Association) and JEIDA (Japan Electronic Industry Development Association) PC card standards.

9.1 Using the Internal Memory

You can only save or load setting conditions in the internal memory.

Save setting conditions

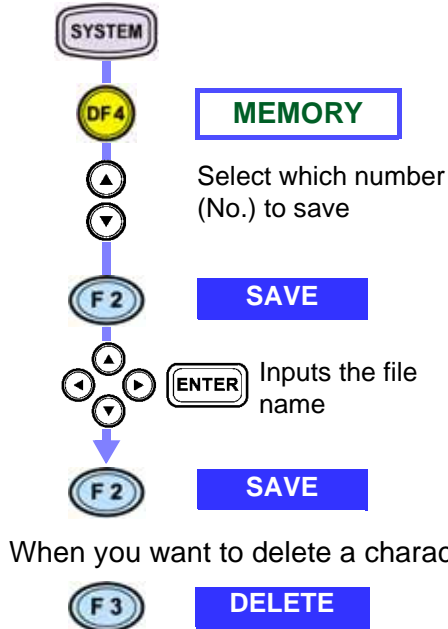

No.	Date	Time	Name
1	06-24	11:47:09	TEST
2	06-24	11:47:25	A_LINE
3	06-24	11:47:51	B_LINE
4	06-24	11:48:08	C_LINE
5	06-24	11:55:45	AC_LOADS

The setting conditions currently set on the 3196 are saved.

Settings file names: up to 8 alphanumeric characters

: Selects characters

: Confirms the selected character

: Backspace (deletes the selected character)

The date and time are recorded automatically.

NOTE

If you do not input a file name, the setting conditions are not saved.

Loading setting conditions

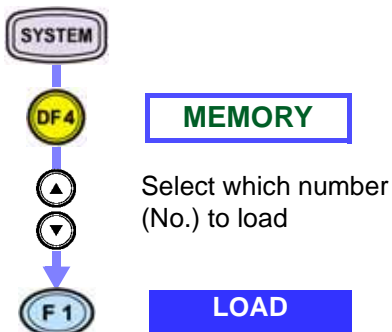

No.	Date	Time	Name
1	06-24	11:47:09	TEST
2	06-24	11:47:25	A_LINE
3	06-24	11:47:51	B_LINE
4	06-24	11:48:08	C_LINE
5	06-24	11:55:45	AC_LOADS

The selected setting conditions are loaded.

Even if you save 10 condition settings, the possible recording time of the time series graph (page 84) does not change.

NOTE

You can only use the internal memory when the operation status is **[SETTING]**.

9.2 Using a PC Card

9.2.1 Selecting a PC Card



Use only PC Cards sold by Hioki.

Compatibility and performance are not guaranteed for PC cards made by other manufacturers. You may be unable to read from or save data to such cards.



- Make sure that you format your PC card before using it. (Format the PC card using this device or the PC.)
- When formatting a PC card on a PC, use the FAT-16 format. Formatting a card in FAT-32 format may result in incompatibility problems.
- Do not use the device where oil permeates the air or in dusty places. Doing so can cause the deterioration of connector contacts.

PC card capacity

The 3196 has an internal memory of 13 MB. Therefore, to transfer all the data recorded in the internal memory to a PC card, you need a PC card with a capacity of 13 MB. We recommend that you use a PC card with a capacity of 13 MB or more.

Hioki options

PC cards (includes adapter)

- 9726 PC CARD 128M
- 9727 PC CARD 256M
- 9728 PC CARD 512M

9.2.2 Inserting and Removing the PC Card

CAUTION

- Trying to force the PC card upside down or to insert the wrong end into the PC card slot, you can damage the PC card and/or this device.
- When you are not using a PC card, keep the cover closed.
- While the PC card is in use, **CARD** is displayed on the upper left of this device. Do not remove the PC card from the device while this mark is present. Doing so can damage the data on the PC card.
- When transporting this device, remove the PC card and close the cover.

Inserting the PC card

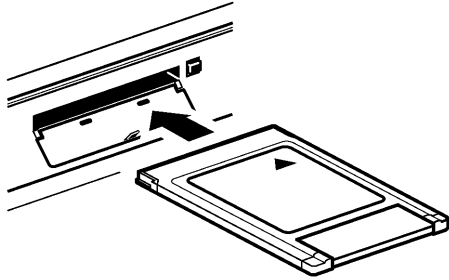

Open the cover and insert the PC Card with the arrow facing up and in the direction of the PC card slot, as far as it will go.

Removing the PC card

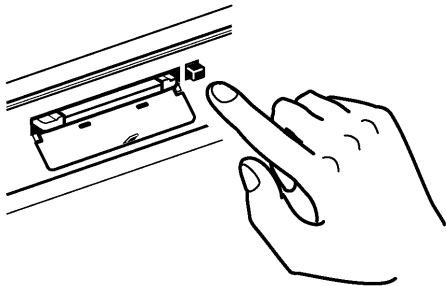

Press the eject button and pull out the PC card.

9.2.3 File Types

Three types of data can be saved to PC cards, including settings, measured data (binary and text format), and screen copy files.

When using Model 9624 PQA HiVIEW or 9624-10 PQA HiVIEW PRO software, save in binary format.

●: Possible/ ×: Not possible

File and Format			Directory name	File name	[SYSTEM]-DF4[PC-CARD]		Open- ing files on a PC	Using with the 9624, 9624-10
					SAVE	LOAD		
Setting Files			_____	#####.SET	●	●	×	×
			B+Date+No.*8	3196SET.SET	●	●	×	●
Measurement Data Files	Binary format	Time-series data *4	_____	96INTVL.ITV	●	●	×	●
		Event data *1, *3		96EVT000.EVT to 96EVT999.EVT	●	●	×	●
		Transient waveform data *1		00000000.TRN to 99999999.TRN	●	●	×	●
		ΔV10/ IEC Flicker data *1		96FLICK.FLC	●	●	×	●
		Voltage fluctuation event data *3,*7		96DV000.WDU to 96DV999.WDU	●	●	×	●
		Time-series data *1		T+Date+No.*8	96INTVL.CSV	●	×	●
	Event list data *1, *5	_____	96EVENT.TXT	●	×	●	×	
	ΔV10/ IEC Flicker data *1	_____	96FLICK.TXT	●	×	●	×	
	Voltage fluctuation event data *3,*7	_____	HHMM000.CSV to HHMM999.CSV	●	×	●	×	
	Event waveform data *2, *6	TEXTWAVE	HHMM000.CSV to HHMM999.CSV *9	●*10	×	●	×	
Screen Hard Copy Files			_____	H3196000.BMP to H3196999.BMP	●	×	●	×
<p>Storage method</p> <p>*1: Files can be saved automatically every interval, or saved manually after measurement is finished (when analyzing).</p> <p>*2: After measurement is finished (when analyzing), you can select an event number and save files manually.</p> <p>*3: Data is saved automatically each time an event occurs.</p> <p>Creating event files</p> <p>*4: A file is created for each event (event data for all of the contents, including waveforms).</p> <p>*5: All of the events in the list are created within a single file.</p> <p>*6: A file is created for each event waveform.</p> <p>*7: A file is created for each voltage fluctuation event graph.</p> <p>Creating a directory and file name</p> <p>*8: A number is appended to files each time measurement data is saved. Binary format: B (1 digit)+ Date (5 digits: year, month, day) + Number (2 digits: 01 to 99) Text format:T (1 digit)+Date (5 digits: year, month, day) + Number (2 digits: 01 to 99) The year is indicated using the lowest digit. (Example: The year 2002 is represented as "2".) 3196SET.SET is also saved in the text format directory.</p> <p>*9: HH indicates hours, and MM indicates minutes.</p> <p>*10: EVENT_DF1[LIST] is used to save event waveform data in text format.</p>								

Binary format file capacity

Time-series data Indicates the capacity of a time-series data file (.ITV) that can be saved at one interval.

	Power	P&Harm	ALL DATA
MAX/MIN/AVE	720 bytes	10320 bytes	15216 bytes
AVE	264 bytes	3464 bytes	5096 bytes

The capacity of data attached to one file is 128 bytes.

Example of calculation:

Capacity of data file acquired in one-hour measurement with recorded data set to Power, MAX/MIN/AVE; and interval to 1 second

File capacity = 128(bytes) + 720(bytes) × 60(sec) × 60(min) = 2,532K bytes

Flicker data Indicates the capacity of a flicker data file (.FLC) saved in one calculation operation.

	Data capacity per calculation operation
ΔV10 Flicker	4 bytes (every minute)
IEC Flicker	24 bytes (every ten minutes)

The capacity of data attached to one file is 136 bytes.

Example of calculation:

Capacity of a data file acquired in one-hour measurement of ΔV10 flicker

File capacity = 136(bytes) + 4(bytes) × 60(min) = 376 bytes

**Event data,
Transient waveform
data,
Voltage fluctuation
event data** Indicates the capacity per each.

Type of data	Capacity per each
Event data (.EVT)	81K bytes
Transient waveform data (.TRN)	17K bytes 34K bytes [For two transient waveforms (positive and negative) within one waveform]
Voltage fluctuation event data (.WDU)	15K bytes

Setting files The setting file (3196SET.SET) capacity is 3.81 Kbytes.

Formatting PC cards



PC-CARD

FORMAT

During formatting, "Now Formatting!" is displayed.
When the message disappears, formatting is finished.

NOTE

Note that formatting a PC card deletes all the files it contains and that they cannot be retrieved.

9.2.4 Saving and Loading Files



- ❖ Loading files (page 147)
- ❖ Deleting files (page 147)
- ❖ Manual saving of the settings files (page 149)
- ❖ Manual saving of the measured data files 1 (Binary format: all data) (page 149)
- ❖ Manual saving of the measured data files 2 (Text format: time-series/ event list/ flicker data) (page 150)
- ❖ Manual saving of the measured data files 3 (Text format: event waveform data) (page 152)
- ❖ Measured data files Auto-save (binary format) settings (page 152)
- ❖ Auto-save measured data file (text format) settings (page 154)
- ❖ Screen hard copies (auto-copy) (page 155)
- ❖ Screen hard copy (manual copy) (page 155)

NOTE

Before saving or loading data using a PC card, insert the PC card. When you select the PC card and there is no PC card present, the following error message appears.

“No card”

To make this error message disappear, press any key.

Loading files

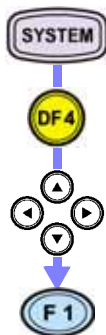

PC-CARD

Select which number (No.) to load

LOAD

No.	File Name	Size	Date
1	B1110901	<DIR>	01-11-09 12:04
2	T1110902	<DIR>	01-11-09 12:04
3	H3196006	BMP 41742	01-11-09 12:03
4	TEST	SET 3904	01-11-09 12:03
5	TEXTWAVE	<DIR>	01-11-09 12:03

When loading settings files, select.SET files.

When loading measured data files, select a directory <DIR> that begins with “B”.

NOTE

- You cannot load text files, BMP files, or file of a type not supported by this device to the 3196.
- When loading binary files, the maximum time it takes to load a file is approximately 5 min.
- The 3196 cannot read binary format files that exceed 13MB in size.
- We recommend the use of the 9624 PQA-HiVIEW to analyze binary format files.

Deleting files

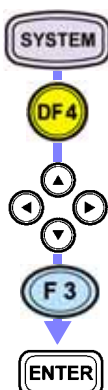

PC-CARD

Select a number (No.)

DELETE

No.	Date	Time	Name
1	06-24	11:47:09	TEST
2	06-24	11:47:25	A_LINE
3	06-24	11:47:51	B_LINE
4	06-24	11:48:08	C_LINE

About file types and saving

Settings file	
Manual save	Auto-save
<p>When the operation status is [SETTING]:</p>  <p>When the operation status is [ANALYZING]:</p>  <p>❖ Manual saving of the settings files (page 149)</p>	
Measured data file	
Manual save	Auto-save
<p>(Binary format: Time-series, Event data)</p> <p>When the operation status is [ANALYZING]:</p>  <p>(Saves all data in the internal memory, including settings files.)</p> <p>❖ Manual saving of the measured data files 1 (Binary format: all data) (page 149)</p>	<p>Saving when the operation status is [RECORDING]: (Auto-save settings required)</p> <p>❖ Measured data files Auto-save (binary format) settings (page 152)</p>
<p>(Text format: Time-series, Event list data)</p> <p>When the operation status is [ANALYZING]:</p>  <p>❖ Manual saving of the measured data files 2 (Text format: time-series/ event list/ flicker data) (page 150)</p>	<p>Saving when the operation status is [RECORDING]: (Auto-save settings required)</p> <p>❖ Auto-save measured data file (text format) settings (page 154)</p>
<p>(Text format: Event waveform data)</p> <p>When the operation status is [ANALYZING]:</p>  <p>❖ Manual saving of the measured data files 3 (Text format: event waveform data) (page 152)</p>	
Screen copy file	
Manual save	Auto-save
 <p>Saving is possible when the operation status is [SETTING], [RECORDING], [ANALYZING].</p>	<p>Saving when the operation status is [RECORDING]: (Auto-save settings required)</p>

Manual saving of the settings files

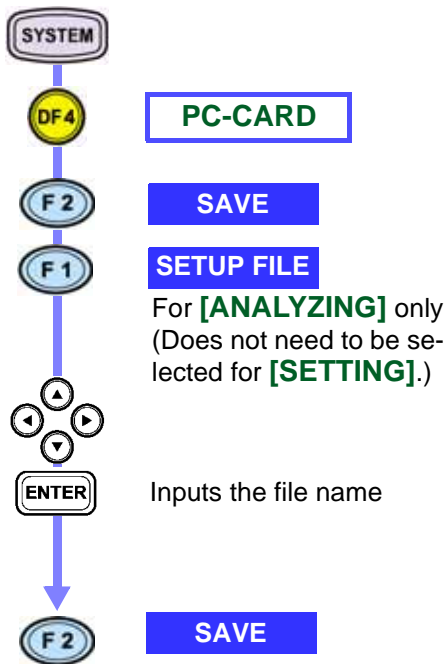

You can save or delete settings files when the operation status is [SETTING] or [ANALYZING].

No.	File Name	Size	Date
1	H3196000 BMP	512	
2	H3196001 BMP	512	

The setting conditions currently set on the 3196 are saved.

Settings file names: up to 8 alphanumerical characters



:Selects characters



: Confirms the selected character



: Backspace (deletes the selected character)

The date and time are recorded automatically.

NOTE

If you do not input a file name, the setting file is not saved.

Manual saving of the measured data files 1 (Binary format: all data)

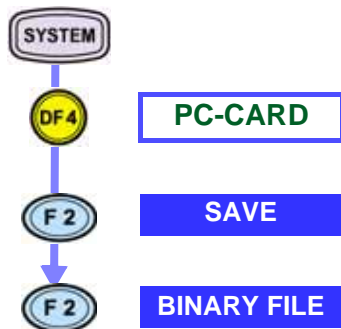

You can save files when the operation status is [SETTING].

No.	Date	Time	Name
1	06-24	11:47:09	TEST
2	06-24	11:47:25	A_LINE
3	06-24	11:47:51	B_LINE
4	06-24	11:48:08	C_LINE

Measured data files contain all data files, and can be saved with settings files in the directory.

Files are saved automatically, with "B" (indicates binary format) and the date and No. used as the directory name.

NOTE

- When saving files in binary format, the maximum time it takes to save files is 4 min 30 s.
When data is saved in binary format, all data in the analyzer's memory is saved to PC card.
- Up to 13 MB in internal memory can be used to store data.
(Time-series data capacity: 5 MB + event data capacity: 8 MB)

Manual saving of the measured data files 2 (Text format: time-series/ event list/ flicker data)

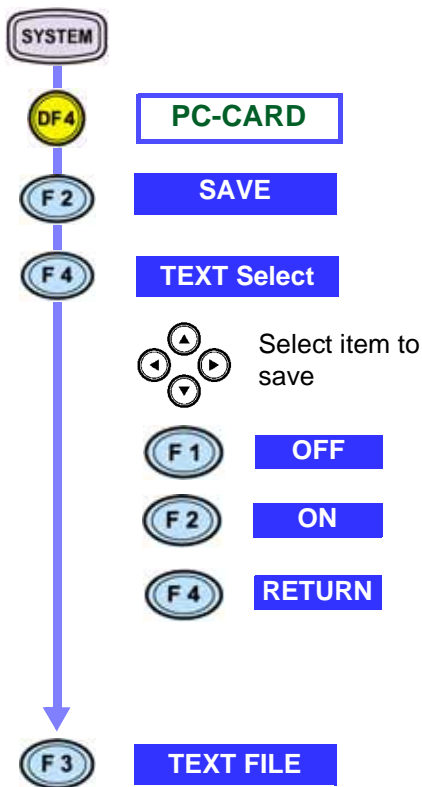

You can save files when the operation status is **[ANALYZING]**.

If you want to change or confirm the files that have been saved, make settings in the text item selection screen.

In [SYSTEM]-DF2[RECORDING], the item selected for the AutoSave setting is the same as the item selected to be saved in the TEXT setting.

Text Save Item Page		3803 item					
Normal Item	Freq	Urms	Upk	Irms	Ipk	Uave	Iave
	ON	ON	ON	ON	ON	ON	ON
Power Item	P	S	Q	PF	KF	Uunb	Iunb
	ON	ON	ON	ON	ON	ON	ON
CH Select	CH 1	CH 2	CH 3	CH 4	sum		
	ON	ON	ON	ON	ON		
Harmonics	U	I	P	angl	iU	iI	iUth
	ON	ON	ON	ON	ON	ON	ON
CH Select	CH 1	CH 2	CH 3	CH 4	sum		
	ON	ON	ON	ON	ON		
Max Order	50						

No.	Date	Time	Name
1	06-24	11:47:09	TEST
2	06-24	11:47:25	A_LINE
3	06-24	11:47:51	B_LINE
4	06-24	11:48:08	C_LINE

Measured data files contain time series graph data, event list data, and flicker data files, and can be saved with settings files in the directory.

Files are saved automatically, with "T" (indicates text format) and the date and No. used as the directory name.

NOTE

In this case, the only measurement data that can be saved to PC card in text format is time series data and event list data.

Event list data and flicker data are saved manually regardless of the TEXT save options.

- ❖ [Text Time-sequence Data-header Composition \(page 223\)](#)
- ❖ [ΔV10 Flicker Text Time-sequence Data-header Composition \(page 226\)](#)
- ❖ [IEC Flicker Text Time-sequence Data-header Composition \(page 226\)](#)
- ❖ [Text Voltage Fluctuation Event Data Format Composition \(page 226\)](#)
- ❖ [Text Event Data-format Composition \(page 227\)](#)

The following table lists the items saved by settings (ON) made on the [Text Select] screen.

	Item	RMS fluctuation graph	Voltage fluctuation graph
Normal Item	Freq	Frequency	—
	Urms	RMS voltage value	RMS voltage value (Voltage fluctuation)
	Upk	Voltage waveform peak	—
	Irms	RMS current value	—
	Ipk	Current waveform peak	—
	Uave	Average RMS voltage value	—
	Iave	Average RMS current value	—
Power Item	P	Active power	—
	S	Apparent power	—
	Q	Reactive power	—
	PF	Power factor/Displacement power factor	—
	KF	K factor	—
	Uunb	Voltage unbalance factor	—
	Iunb	Current unbalance factor	—
	UTHD	Total harmonic voltage distortion factor	—
	ITHD	Total harmonic current distortion factor	—
Harmonics	U	Harmonic voltage	—
	I	Harmonic current	—
	P	Harmonic power	—
	angl	Harmonic voltage-current phase difference	—
	iU	Inter-harmonic voltage	—
	il	Inter-harmonic current	—
	iUth	Total Inter-harmonic voltage distortion factor	—
	ilth	Total Inter-harmonic current distortion factor	—

Manual saving of the measured data files 3 (Text format: event waveform data)

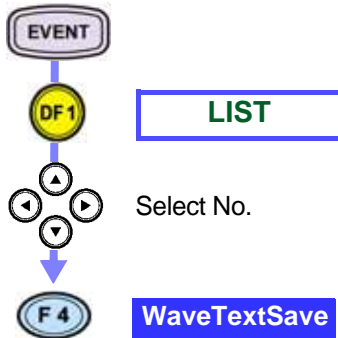

To save multiple event waveforms, select a number (No.) and repeat the process.

You can save files when the operation status is **[ANALYZING]**.

No.	Date	Time	Event	Category
2	11-09	15:42:34.196	Wave	CH1
3	11-09	15:42:33.994	U_THD	CH1 OUT
4	11-09	15:42:33.844	Inter	CH1 OUT
5	11-09	15:42:29.194	U_THD	CH1 IN
6	11-09	15:42:29.127	Di...	CH1 IN

Waveforms that can be saved differ depending on the connection method setting.

(Wiring method)

1P2W U1, I1
 1P3W U1, U2, I1, I2
 3P3W2M U1, U2, I1, I2
 3P3W3M U1 to U3, I1 to I3
 3P4W U1 to U3, I1 to I3
 4ch:AC/DC.... U4, I4

❖ [Text Event Waveform Data Format Composition \(page 226\)](#)

NOTE

Transient waveform data cannot be saved in text format.

Measured data files Auto-save (binary format) settings

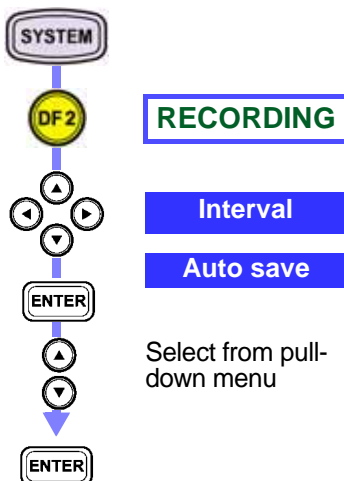

Interval

Auto save

Select from pull-down menu

Measured data files are automatically saved to the PC card with the internal memory.

1. Set the interval. (page 84)
1, 3, 15, or 30 sec, 1, 5, 10, 15, or 30 min, 1/2 hour
2. Set the auto-save format.
BINARY

NOTE

- Measured data files are saved automatically during recording. While auto-save is in progress, do not remove the PC card from the 3196.
- In binary format, all measurement data of the 3196 can be saved to a PC card.

When the memory is full

When the memory is full: **STOP**

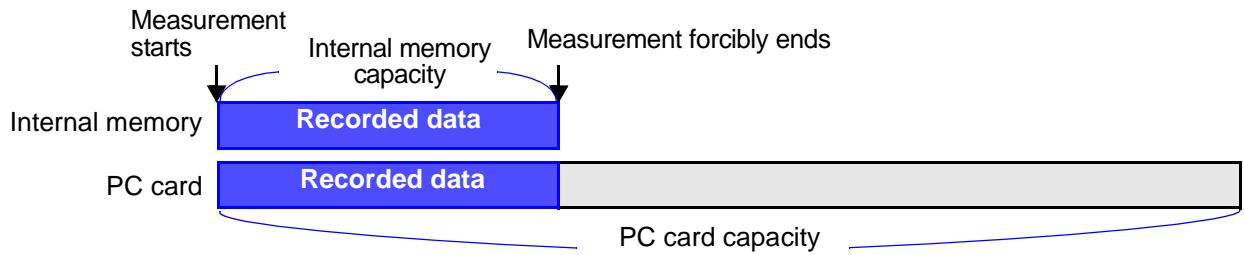

When the memory is full: **LOOP**

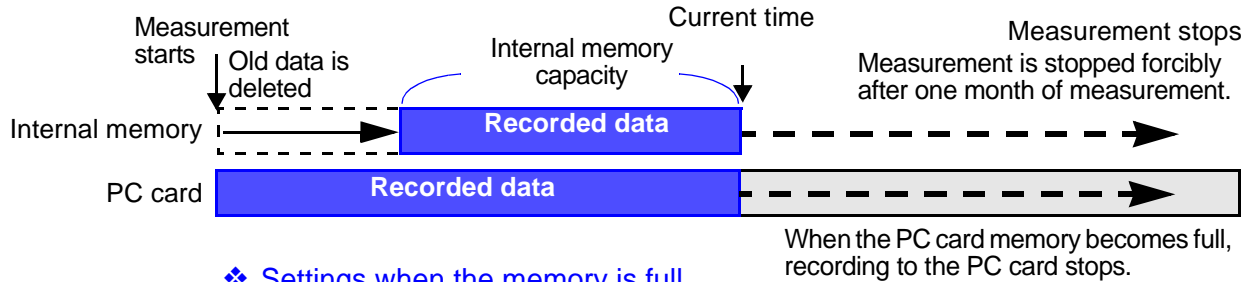

❖ Settings when the memory is full (page 83)

Auto-save measured data file (text format) settings

SYSTEM

DF2

RECORDING

Interval

Auto Save



ENTER



Select from pull-down menu

ENTER

F1

SELECT



Select the item to be saved.

F1

OFF

F2

ON

F4

RETURN

Measured data files are saved to the PC card with the internal memory automatically.

1. Set the interval. (page 84)
1, 3, 15, or 30 sec, 1, 5, 10, 15, or 30 min, 1/2 hour
2. Set the auto-save format.
TEXT

Rec. Data	ALL DATA	MAX/MIN/AVE
MemoryFull	STOP	
Interval	1 sec	00:00:05:45
Auto Save	TEXT	7 item
Time Start	OFF	

Text Save Item Page		3303 item							
	Freq	Urms	Upk	Irms	Ipk	Uave	Iave		
Normal Item	ON	ON	ON	ON	ON	ON	ON		
	P	S	Q	PF	KF	Uunb	Iunb	UTHD	ITHD
Power Item	ON	ON	ON	ON	ON	ON	ON	ON	ON
	CH 1	CH 2	CH 3	CH 4	sum				
CH Select	ON	ON	ON	ON	ON				
	U	I	P	angl	iU	iI	iUth	iIth	
Harmonics	ON	ON	ON	ON	ON	ON	ON	ON	
	CH 1	CH 2	CH 3	CH 4	sum				
CH Select	ON	ON	ON	ON	ON				
Max Order	50								

Select the item to be saved.

The item currently selected appears to the right of the auto-save settings.

OFF: Not selected as an item to be saved as text.

ON: Selected as an item to be saved as text.

Files are saved automatically when the internal operation status becomes **[RECORDING]**.

Measured data files are saved automatically during recording.

NOTE

- While auto-save is in progress, do not remove the PC card from the 3196.
- In this case, the only measurement data that can be saved to PC card in text format is time series data, event list data, flicker data, and voltage fluctuation event data.
- Event list data, flicker data, and voltage fluctuation event data are automatically saved as text, regardless of the TEXT save options.
- Settings selected in the text save options also apply when manually saving text data.
- ❖ Manual saving of the measured data files 2 (Text format: time-series/ event list/ flicker data) (page 150)

Screen hard copies (auto-copy)

SYSTEM

DF 2

HARDWARE

▲
▼

RS-232C

1. Set the RS connection point.

OFF or **MODEM**

ENTER

Timer

2. Set to Timer.

COPY

▲
▼

Select from pull-down menu

3. Set the interval.

1 min, 5 min, 10 min, 30 min, 1 hour, 2 hour

ENTER

Files are automatically copied to the PC card when the internal operation status becomes **[RECORDING]**.

Display the screen that you want to hard copy.

Screen hard copy (manual copy)

Display the screen that you want to hard copy.

You can copy screens as BMP files to the PC card manually. The RS connection point settings are the same as for auto-copy.



Saves the displayed screen when pressed.

NOTE

In addition to being able to save screen images to the PC card, hard copies allow you to output them to a printer.

When the RS connection point is set to PRINTER, a hard copy of the screen image is sent to the printer. For other settings, the hard copy of the screen image is sent to the PC card.

Using a Printer *Chapter 10*

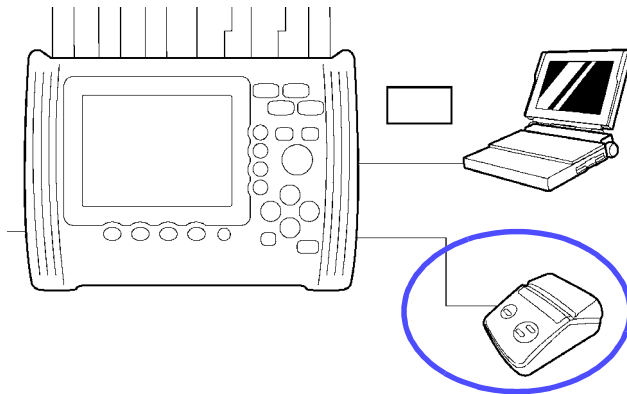

Using the device's RS-232C interface, you can create hard copies of the 3196 screen with the 9670 PRINTER.

For details about the printer and printer connection methods, Refer to the Quick Start Guide.

10.1 Setting the Printer

Setting the RS-232C connection point on the printer

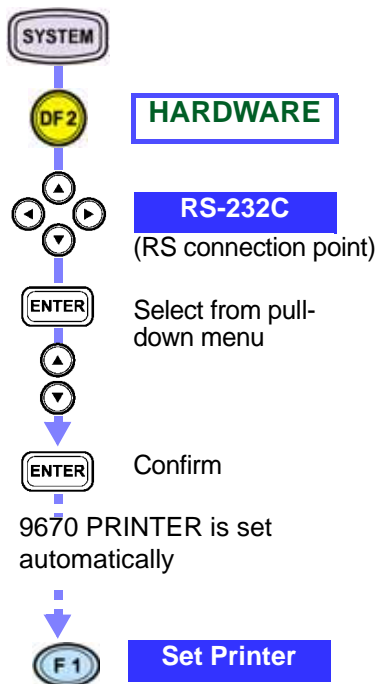

Smart Print	OFF			
RS-232C	OFF	57600bps		
Timer	OFF	1 min		
IP Address	192	168	0	1
Net Mask	255	255	255	0
System Reset				00:01:67:00:07:62

1. Set the RS connection point to **PRINTER**.
2. Set the appropriate baud rate.
9600 bps (slow printing), **19200 bps** (mid-speed printing), **38400 bps** (fast printing)

When this is set to PRINTER,  lights on the upper left of the screen.

The baud rate and language set on this device as well as the auto-power off function (OFF) are set automatically in the 9670 PRINTER.

After the printer is set automatically, turn off the printer and turn it on again before using it.

10.2 Printing Hard Copies

The two methods to create screen hard copies with the printer are to output them automatically at each set interval or to output them manually by pressing the HARD COPY key.

Printing screen images automatically

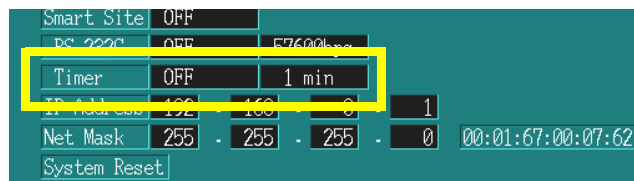
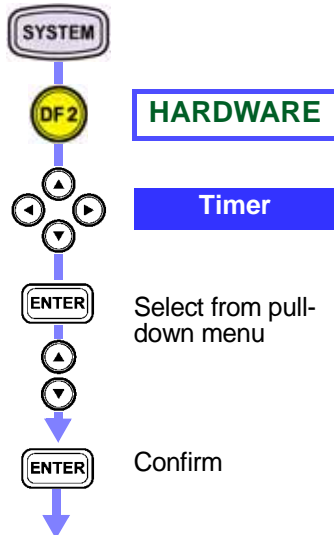

1. Set the Timer function.
COPY
2. Set the output interval.
1 min, 5 min, 10 min, 30 min, 1 hour, 2 hour
3. Set the connection point to **PRINTER**.

Display the screen that you want to hard copy.

Screen images are output automatically when the internal operation status becomes **[RECORDING]**.

Printing screen images manually

Display the screen that you want to hard copy.

Set the RS connection point to **PRINTER**.



Prints the displayed screen when pressed.

NOTE

- In addition to being able to print screen images, hard copy allows you to save screen images to the PC card.
- When the RS connection point is set to PRINTER, a hard copy of the screen image is output by the printer. (When screen images can be output to the printer,  lights on the upper left of the screen.) For all other settings, the screen image is saved to the PC card.

Using the PC *Chapter 11*

This device is equipped with an RS-232C and a LAN interface.

This section describes how to use the device with a personal computer (hereafter, PC) and a modem. You can use the HTTP server function *1 installed on this device or "Down96" (CD-R) with all the connection methods outlined above.

1 Connecting the 3196 to a modem using the RS-232C cable and controlling/observing the 3196 from a PC connected to the modem

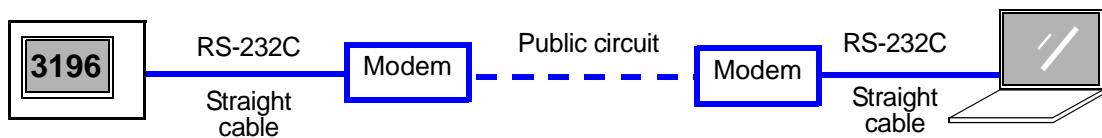

❖ [11.1 "Remote Control and Monitoring Using an RS-232C Interface" \(page 160\)](#)

2 Connecting the 3196 to a hub using a LAN cable and controlling/observing the 3196 from a PC

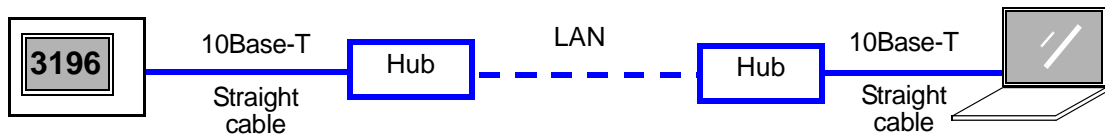

❖ [11.2 "Control and Monitoring Using a LAN Interface" \(page 167\)](#)

3 Connecting the 3196 to a PC with a LAN cable and controlling/observing the 3196

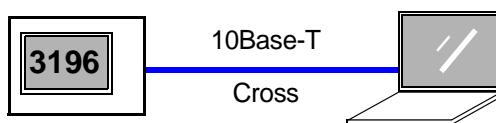

❖ [11.2 "Control and Monitoring Using a LAN Interface" \(page 167\)](#)

*1: The HTTP server function allows you to use any Internet browser, such as Internet Explorer, without having to install dedicated software on the PC to make settings for the 3196, acquire data, or observe screens.

❖ [HTTP Server Function \(page 174\)](#)

*2: The Down96 download application software downloads data files stored in internal memory of the main unit or on the PC card to a PC.

For details, see the Down96 Instruction manual (CD-R version)

- Both the RS-232C and LAN interfaces use TCP/IP. The connection protocol to use TCP/IP with an RS-232C interface is PPP (Point-to-Point Protocol). Note that you cannot use programs such as Visual Basic to send commands or receive data on the PC.
- Windows, MS-Excel, MS-Word are either registered trademarks of Microsoft Corporation in the United States and other countries.

11.1 Remote Control and Monitoring Using an RS-232C Interface

- 1** The instrument can be connected by RS-232C cable to a modem for remote control and monitoring from a PC at another location using a public circuit or cellular phone.

When the modem is directly connected to a public circuit:

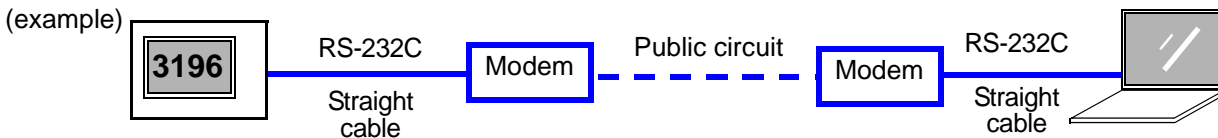

When the modem is connected to a cellular phone:

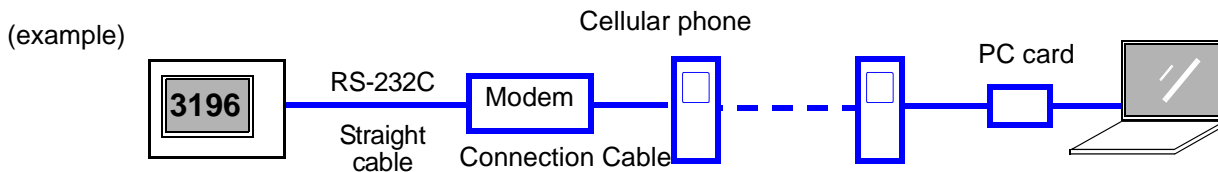

Procedure

- 1.** Connect the instrument to the modem using an RS-232C cable (straight cable).
Connecting method: Refer to the Quick Start Manual.
❖ 11.1.1 "Connecting a Modem" (page 161)
- 2.** Make connection point settings on the 3196
❖ 11.1.2 "Setting the 3196" (page 162)
- 3.** Make 3196 settings using the PC
❖ 11.1.3 "Setting the PC" (page 163)

NOTE

- The settings of the modem connected to this device are made automatically by the 3196. After reading the user's guide of the PC and modem, set the modem connected to the PC.
- Make the same connection and settings even when using the HTTP server function or Down96 download application software.

11.1.1 Connecting a Modem

Connecting method: Refer to the Quick Start Manual.

When the modem is directly connected to a public circuit:

Prepare the following:

Modem for this instrument	A computer modem capable of speeds of 28.8 kbps or more is recommended. A modem that connects to an RS-232C terminal (modems that connect to a USB port or PC card slot cannot be used). Operationally confirmed model: DFML-560E, made by I-O Data Note: Models that do not have an "E" appended to the end of their model number use a USB connection, and cannot be used.
RS-232C cable	Straight cable (supplied with the modem)
Modem for the PC	Any modem that can be used with the PC you are using. If your PC supports USB connections: USB connection-type modem If your PC does not support USB connection: RS-232C connection-type modem Notebook computer: PC card-type modem
Make sure that a phone line is available both at the place where you set up the 3196 and near your PC.	

When the modem is connected to a cellular phone:

Prepare the following:

Modem for connecting a cellular phone to the Instrument	Mobile communications adapter Model certified for use: TD-PHSAD, made by Telecom Electronics
RS-232C cable	Straight cable (supplied with the mobile communications adapter)
Cable for connecting a cellular phone to the modem	PHS cellular cable (when using a PHS cellular phone) PDC cable (when using a cellular phone) (these cables are supplied with the mobile communications adapter)
Modem for the PC	Any modem that can be used with the PC you are using. Model certified for use with a PC card when connecting the cellular phone to your PC: PCMA-9664P2, made by I-O Data
Further, to avoid using up the remaining battery life for your cellular phone during use, make sure you use the optional charger or AC adapter for the cellular phone you are using. When using the "remote control application" of the HTTP server function, it is recommended that you connect a PHS cellular phone with a fast communication speed to your PC instead of connecting a regular cellular phone.	

11.1.2 Setting the 3196

Configuring connection on the instrument

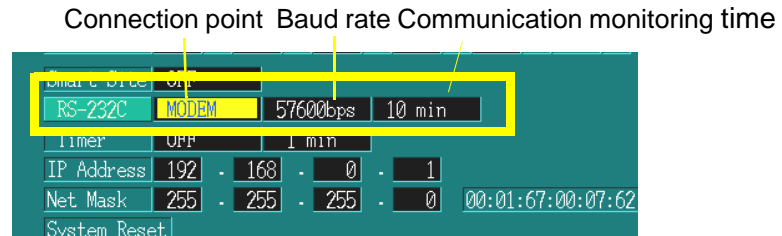
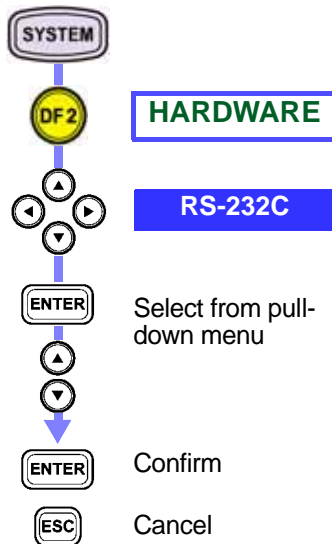

1. Set the connection point.

MODEM

When the connection point is set to **MODEM**,  lights on the upper left of the screen.

2. Set the baud rate.
57600 bps and so on
3. Set the communication monitoring time that applies to modem connection.
The analyzer is automatically disconnected after the selected amount of time (**OFF, 1 min, 5 min, 10 min, or 30 min**) elapses without communication.

Except for the baud rate, all RS-232C settings are set as follows.

Transfer method: Asynchronous communication method

Data length: 8 bits

Parity check: None (OFF)

Stop bit: 1

Flow control: None

Delimiter (sender, receiver): CR+ LF

As an example, assume the IP address is to be set to 192.168.0.1, and the subnet mask is to be set to 255.255.255.0.

❖ [TCP/IP settings on the computer \(page 165\)](#)

After you have finished making the instrument settings, turn on the modem's power.

11.1.3 Setting the PC

Example

Computer OS Windows 98
Modem When using the DFML-560E made by I-O Data

Dial-up settings

1 Open [Dial-Up Networking].



Double-click [Dial-Up Networking] in [My Computer], and open [Make New Connection].

2 Set the dial-up connection point.

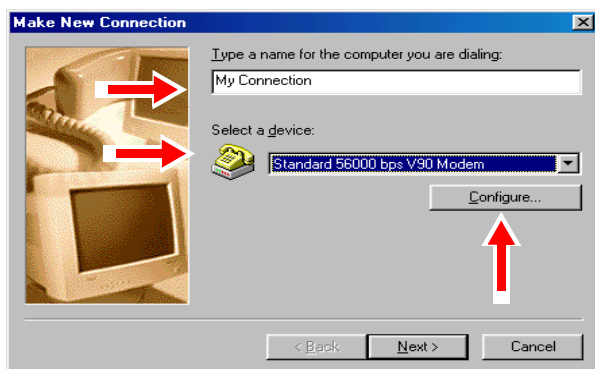

1. Type a name (example: [3196]) in the connection name entry box.
2. For the modem setting, select the modem that is to be used.
* If you cannot select the modem here, install the modem beforehand.
3. Press the [Configure...] button.

The Properties screen opens.

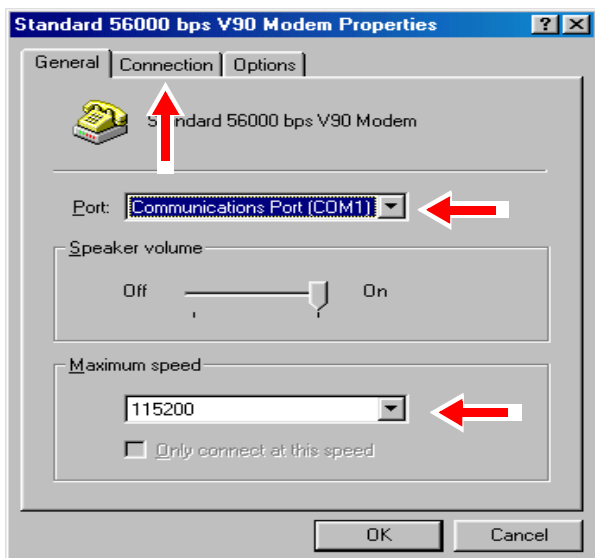

4. Check that the communications port is the same port that the modem is connected to.
5. Select [115200] bps (normal) as the maximum speed.
6. Check that the setting is correct, and click the [Connection] tab.

11.1 Remote Control and Monitoring Using an RS-232C Interface

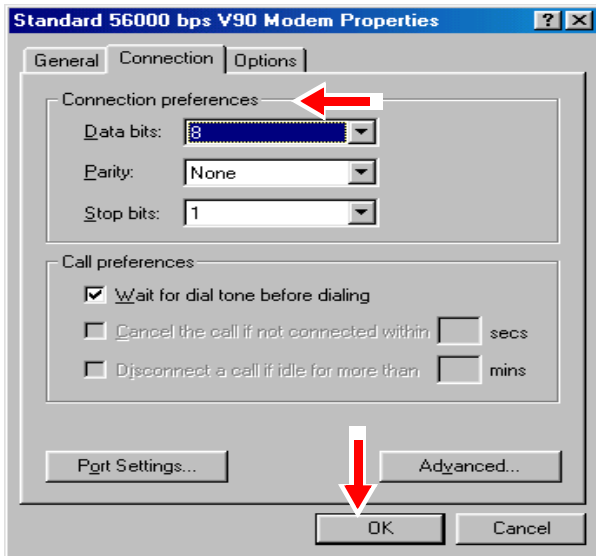

7. Set the [Connection preferences] as shown on the left.

* Normally, do not change [Call preferences] from the default setting.

If you are having trouble connecting using an internal line, remove the [Wait for dial tone before dialing] checkmark and try again.

8. Confirm that the settings are correct and press the [OK] button, then press the [Next] button in the original dialog box.

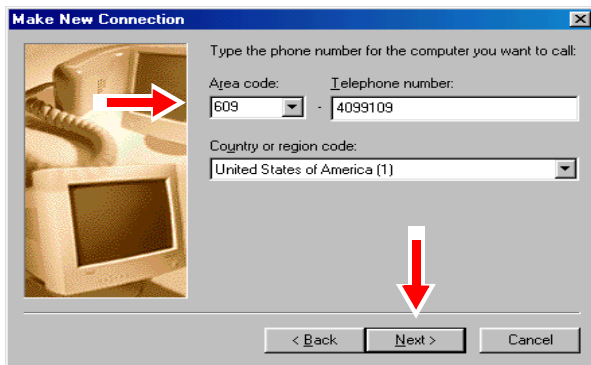

9. Type the telephone number that the instrument is connected to.

10. After you have entered the number, press the [Next] button. To complete Dial-Up Networking settings, press the [Finish] button on the final confirmation screen.

3 Set the connection properties.

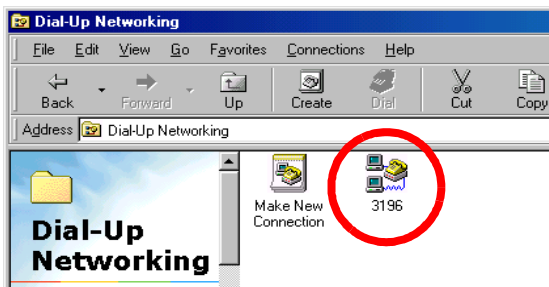

A "3196" connection icon is created.

Right-click the [3196] icon, or select [Properties] from the [File] menu.

A dialog box like the one in the diagram opens.

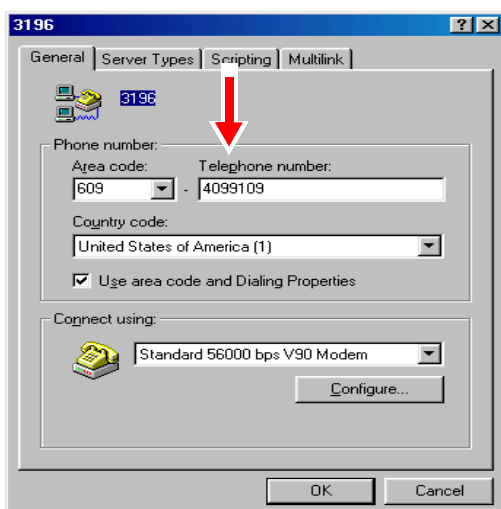

Confirm the telephone number for the 3196.

11.1 Remote Control and Monitoring Using an RS-232C Interface

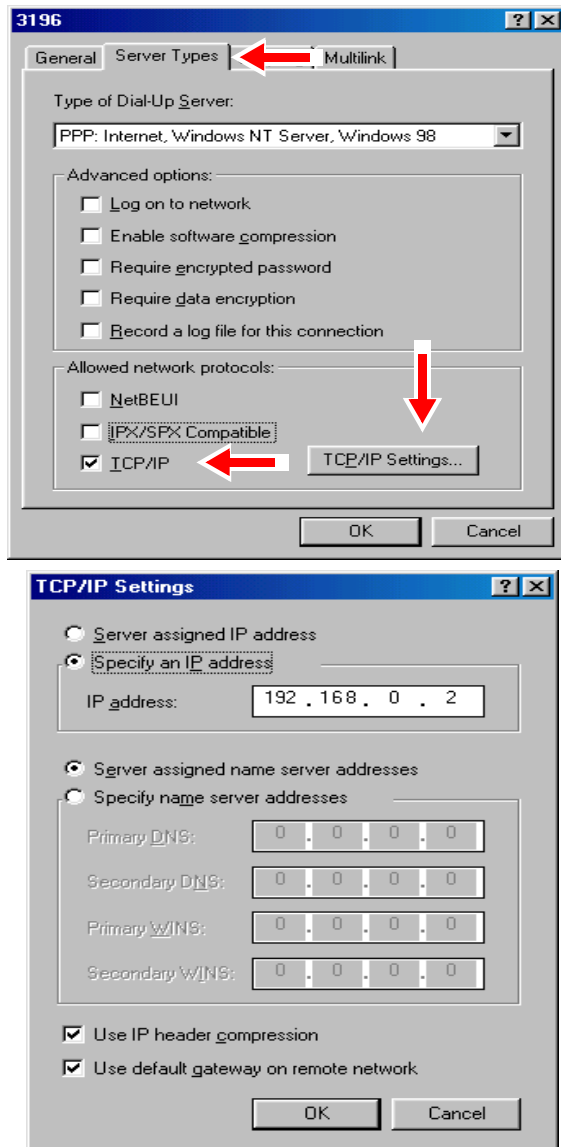

11. Select the [Server Types] tab, and make settings as shown in the diagram.

Select [TCP/IP] only.

12. Press the [TCP/IP Settings...] button.

* Leave options on other sheets set to their default settings.

13. Once the [TCP/IP Settings] dialog box opens, make settings as shown in the diagram.

* In [IP address], be careful not to set the same IP address as that set for the 3196. For example, if you find that the setting on the computer is 192.168.0.2, then you could set the address on the instrument to something like 192.168.0.1.

14. After you have finished making the settings, press the [OK] button.

* If you are having trouble making the connection, remove the [Use IP header compression] checkmark, and try again.

Connection to the instrument

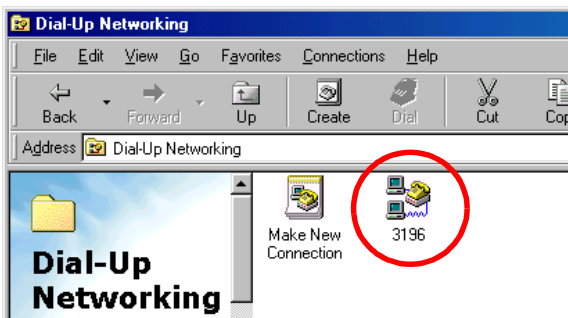

1. Double-click the [3196] icon.

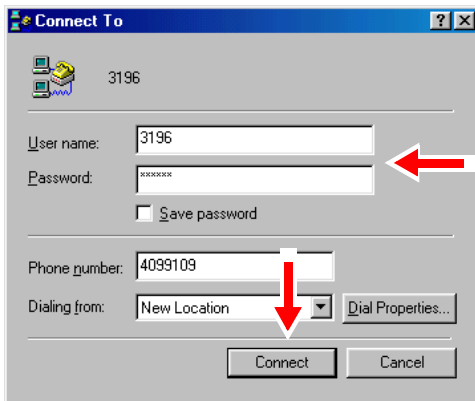

2. Type [3196] in the user name entry box, and [PASSWD] in the password entry box.

3. Check whether the telephone number for the instrument is correct, and press the [Connect] button.

The [Connecting to 3196] dialog box opens.

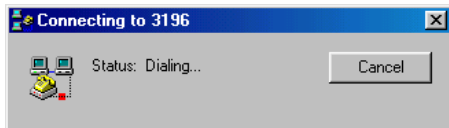

4. Start up Internet Explorer, and enter the IP address that you set for the instrument (such as http://192.168.0.1/) in the address column, then press the Enter key.

When a normal connection is established, the Main page for the instrument's HTTP server function opens.

Configure Internet Explorer so that it does not use a proxy server.

(You can configure the [Use proxy server] option by clicking [Internet Options] on Internet Explorer's [Tools] menu, then clicking the [Connections] tab.

11.2 Control and Monitoring Using a LAN Interface

2 Connecting the 3196 to a hub using a LAN cable and controlling/observing the 3196 from a PC

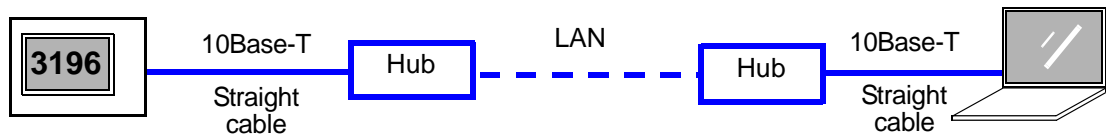

3 Connecting the 3196 to a PC with a LAN cable and controlling/observing the 3196

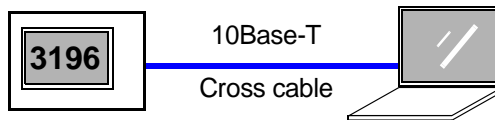

Procedure

1. **Connect the instrument to a hub or computer with a LAN cable.**
 When connecting to a hub: 10BASE-T terminal, straight cable
 When connecting to a computer: 10BASE-T terminal, cross cable

Connecting method: Refer to the Quick Start Manual.

❖ 11.2.1 "Connecting the 3196" (page 168)

2. **Make connection point settings on the 3196**

❖ 11.2.2 "Setting the 3196" (page 168)

3. **Make 3196 settings using the PC**

- Host name (up to 12 characters)
- IP address (**.***.***.***) **:3 characters
- Subnet mask (**.***.***.***) **:3 characters
- Default gateway **ON** or **OFF**
- Gateway (**.***.***.***) **:3 characters

❖ 11.2.3 "Setting the PC" (page 172)

NOTE

Make the same connection and settings even when using the HTTP server function or Down96 download application software.

11.2.1 Connecting the 3196

Connecting method: Refer to the Quick Start Manual.

When connecting the instrument and computer through a hub:

Prepare the following:

Hub	A commercially sold hub.
10BASE-T cable	Straight cable (9642 LAN cable, you cannot use the supplied cross conversion cable)

When connecting the instrument and computer directly:

Prepare the following:

10BASE-T cable	Cross cable (9642 LAN cable, using the supplied cross conversion cable)
----------------	---

11.2.2 Setting the 3196

Configure connection on the instrument.

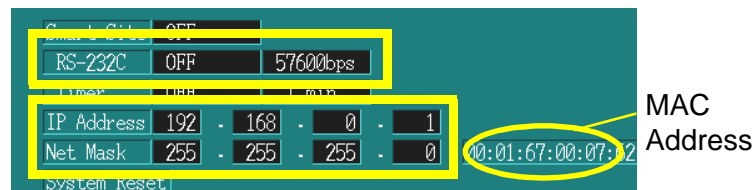
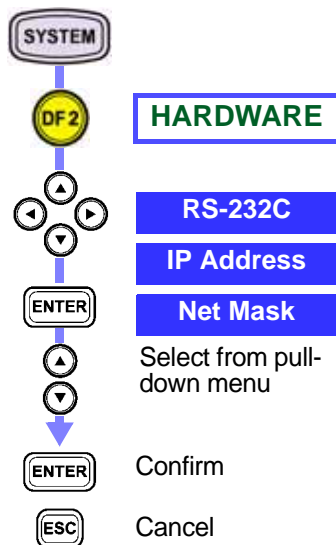

1. Set the connection point.
OFF or **PRINTER**
2. Set the IP address.
..***
3. Set the subnet mask.
..***

When the connection point is set to OFF or PRINTER,  lights on the upper left of the screen.

Example:

How to Set the Instrument's IP Address and Subnet Mask
When the computer's IP address and subnet mask are as follows:

IP address: 192.168.0.2

Subnet mask: 255.255.255.0

IP address of the 3196: 192.168.0.1

Set the last numerical value only in the computer's IP address to a different number.

Subnet mask of the 3196: 255.255.255.0

Set to the same value as the computer's subnet mask.

NOTE

- The number displayed to the right of the “Net Mask” is the MAC Address. This is the same as on the MAC Address label on the back panel.
- When you set the printer as the RS connection point, you can use the printer and LAN simultaneously. When you set the modem as the connection point, you cannot use the LAN.
- When communicating with this device and a PC through a LAN, make the proper network settings on this device.
- When connecting to an existing LAN network, consult your system administrator.
- This device does not support DHCP (an IP address automatic acquisition function).

About the settings**IP address**

The TCP/IP used for LAN communications with this device uses an IP address to differentiate each device.

With IP version 4 (IPv4), widely used at present, IP addresses consist of 32-bit numbers. Normally, decimal notation is used to express each octet (8 bits) of the IP address, such as in 192.168.1.1, and this expression is joined with a period(.).

Network mask

IP addresses can be divided in 2: the network portion, expressing the network position where devices are connected; and the host portion that identifies devices on the network.

The net mask is used to indicate the ranges of the network and host portions. The net mask expresses the bit corresponding to the network portion as “1”, and the bit corresponding to the host portion as “0”.

(Example: When the network is assigned to the first 24 bits and the host is assigned to the remaining 8 bits:

```
11111111 11111111 11111111 00000000
```

Normally, the IP address is expressed as a hexadecimal number (0xfffff00) or as a decimal number (255.255.255.0).

Also, the length (number of bits) of the network portion can be expressed as 192.168.1.0/24. In this case, the “24” that follows the “/” indicates that the network portion is 24 bits.

Subnet mask

Except in an extremely limited number of cases, when constructing a network within an organization, the network is usually divided in several smaller networks. In this case, each division of the IP network is referred to as a subnetwork.

When the network is divided into subnetworks, the host portion of the IP address is assigned to the subnetwork and the host, and you can use the net mask to delimit the subnetwork and host portions. In this case, the net mask is referred to as a subnet mask.

11.2 Control and Monitoring Using a LAN Interface

IP address assignment Because each device must have a unique address, IP addresses are monitored by the RIR (Regional Internet Registry). Usually, an ISP (internet service provider) is entrusted with the assignment of IP addresses to businesses, alleviating users of that ISP from any problems. Otherwise, certain IP addresses can be used freely within a distinct, closed network, as defined by RFC1597, as follows:

10.0.0.0/8	10. 0. 0. 0 to 10.255.255.255
172.16.0.0/12	172. 16. 0. 0 to 172. 31.255.255
192.168.0.0/16	192.168. 0. 0 to 192.168.255.255

When using a cross cable to communicate on a locally between the PC and this unit, or to communicate through a closed IP network, select one of the addresses above.

However, addresses where the host portion bits are all "0" are used as network addresses only to identify the network itself. Addresses where the host portion bits are all "1" cannot be used as IP addresses because they indicate all the hosts that exist on the network.

(Example: For an IP network that has a network address (192.168.1.0/24):

The address 192.168.1.255 indicates all the devices that are connected to 192.168.1.0/24.

Because 254 IP addresses (192.168.1.1 to 192.168.1.254, except 192.168.1.0 and 192.168.1.255) can be used on this network, up to 254 devices can be connected to the network.

Gateway The gateway is a device that connects different networks. On an IP network, devices that connect different IP networks use a common router. You must specify the router's IP address as the gateway address.

In the 3196, there is no gateway setting.

Host name With TCP/IP, individual devices are differentiated by their IP addresses. However, IP addresses are hard to understand and difficult to remember. Unlike IP addresses, a text string host name is assigned and this is used instead of the IP address.

The IP address and host name are changed depending on the DNS (Domain Name Server).

In the 3196, there is no host name setting.

Example of a network environment structure

Example 1: Connecting the 3196 to an existing network

When you connect the 3196 to an existing network, the system administrator must make the settings beforehand.

Make sure that the settings are unique to this device.

Note the following settings assigned by your system administrator.

IP address	_____
Subnet mask	_____

Example 2: Connecting several 3196 units to a single PC through a hub

When assembling a isolated local network, it is recommended that you use private IP addresses.

When assembling the network with the network address 192.168.1.0/24:

IP address PC: 192.168.1.1

This device: Add in the following order: 192.168.1.2, 192.168.1.3,
192.168.1.4, and so on.

Subnet mask 255.255.255.0

Example 3: Connecting the 3196 locally to a PC using the 9642 LAN CABLE

When connecting the 3196 locally to a PC using the connector supplied with the 9642 LAN CABLE, you can set the desired IP address, but we recommend that you use a private IP address.

IP address PC: 192.168.1.1

This device: 192.168.1.2 (Set the IP address to a different value.)

Subnet mask 255.255.255.0

11.2.3 Setting the PC

Example

Computer OS Windows 98

When connecting the instrument and computer directly:

Confirm the properties for Internet protocol (TCP/IP).



1. Move the cursor over **[Network Neighborhood]** and right-click the mouse to open the local area connection properties.

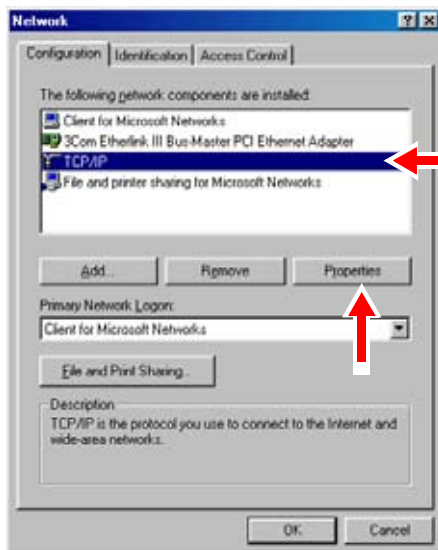

2. Select **[TCP/IP]**, and press the **[Properties]** button.

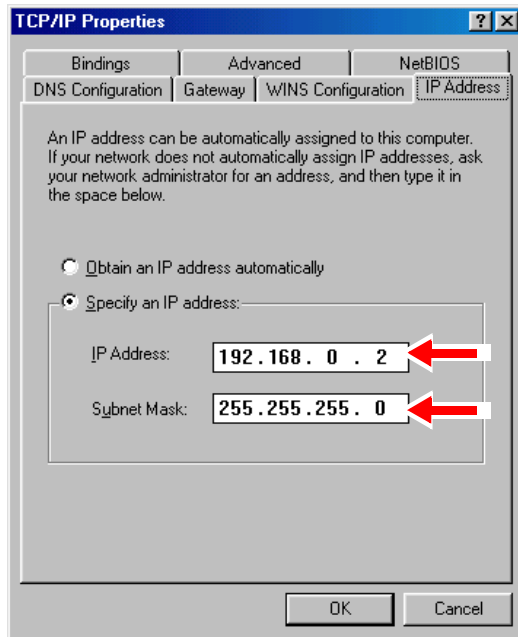

3. Confirm the IP address and subnet mask for the computer you are using.

Do not check the **[Obtain an IP address automatically]** option.

To set the instrument's IP address, change the final numerical value only for the computer's IP address.

To set the instrument's subnet mask, set the same value as the computer's subnet mask.

Example:

PC

IP address: 192.168.0.2

Subnet mask: 255.255.255.0

3196

IP address: 192.168.0.1

Subnet mask: 255.255.255.0

Connection to the instrument

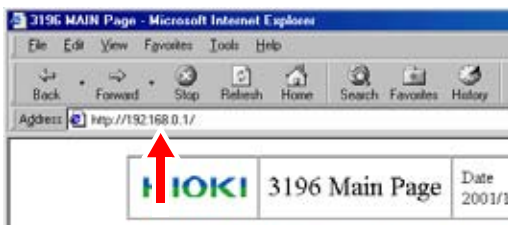

Start up Internet Explorer, and enter the IP address that you set for the instrument (such as `http://192.168.0.1`) in the address column, then press the Enter key.

When a normal connection is established, the Main page for the instrument's HTTP server function opens.

Configuration of Internet Explorer:

- Deselect the **[Use proxy server]** option.
- Configure Internet Explorer so that it does not use a proxy server by clicking **[Internet Options]** on Internet Explorer's **[Tools]** menu, then clicking the **[Connections]** tab.

If connection fails:

Check the following items.

- Verify that you are using a straight LAN cable. If you are using a straight LAN cable, the computer's LINK LED lights.
- Verify that you set the IP address and subnet mask.
- Verify that the instrument's RS connection point is the modem.
- Verify that you are receiving a normal response from the ping command on the computer's DOS prompt screen.
- Verify that the checkmark is removed from the Internet browser proxy setting.

11.3 HTTP Server Function

11.3.1 Overview

The HTTP server function allows you to use any Internet browser, such as Internet Explorer, without having to install dedicated software on the PC to make settings for the 3196, acquire data, or observe screens. You can use the following functions.

However, functions other than the remote control application function are supported by version 1.02 or later of this instrument.

Remote control application

Displays the screen currently displayed on the 3196 in the Internet browser.

- You can enter the keys so that they are in the same position as the keys on the 3196.
- You can select from a black and white or color display, and select the screen update rate.

Event list

Displays the event list stored in this device's internal memory on the Internet browser.

- By selecting an event, you can display the details, waveform, vector, and harmonic bar graph for the time that event occurred.
- You can also convert the voltage and current waveforms for the time the event occurred directly into text, and edit the data in MS-Excel.
- When using Internet Explorer as the Internet browser, you can edit the data in MS-Word and use it to create a report.

System settings

You can make all of the settings for the instrument's **[SYSTEM]** screen using an Internet browser.

Starting and finishing measurement

You can control the start and finish of measurement using the Internet browser.

NOTE

Internet Explorer Version 4 or later is supported.
You can also use Netscape Navigator, but some screens may not operate correctly.

11.3.2 Setting the HTTP Server Function

Main Page

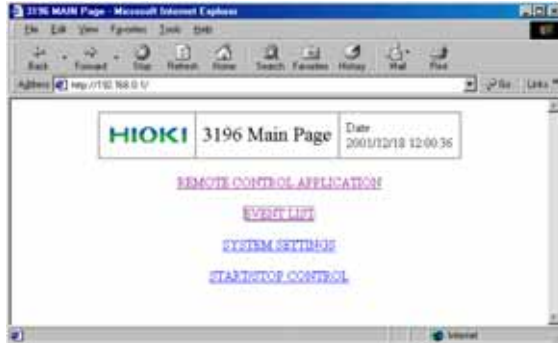

Start up Internet Explorer, and enter the IP address that you set for the instrument (example: <http://192.168.0.1/>) in the address column, then press the Enter key.

When a normal connection is established, the Main page for the instrument's HTTP server function opens.

To shift between the various screens, click the mouse as you would on a normal homepage.

Remote Control Application Screen



The screen displayed on the Internet browser is the same as the screen displayed on the instrument with the same key placement as the front panel.

You can control the operation of the instrument by clicking each key.

Select **[MONO/COLOR]**, then select a screen update rate from **OFF**, **2 sec**, **10 sec**, and **1 min**.

When the remote control application starts, **[MONO]** (displays keys only) is set as the default, but you should change this to **[COLOR]** before using the application.

Event List Screen

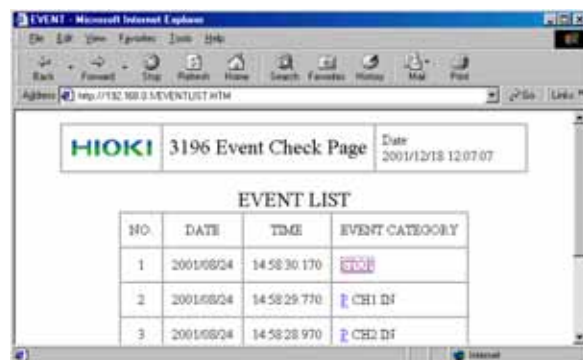

The screen displays a list of the events currently recorded in this device's internal memory. Click an event category to display the event details screen (detailed information for the time the event occurred).

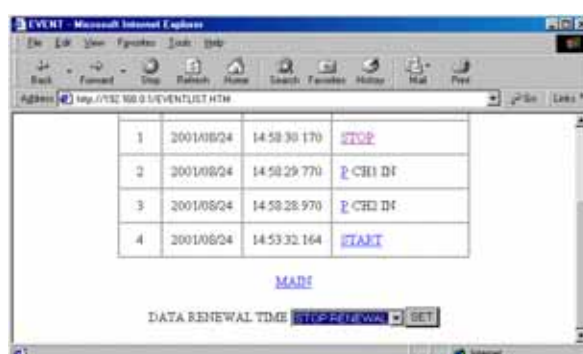

On the event list screen, you can select a display update interval (STOP RENEWAL, 5 SEC, 10 SEC, 30 SEC, 1 MIN, 15 MIN, 30 MIN, or 1H).

Event Detailed Screen

Just like the instrument, this screen displays a list of representational event categories and simultaneously occurring events.

You can also display waveforms, vectors, and harmonics for event occurrence by selecting a graph.

The Internet browser displays the same screen as the instrument's analysis screen when an event occurrence is moved from the event list screen using the **ENTER** key.

Event Waveform Screen

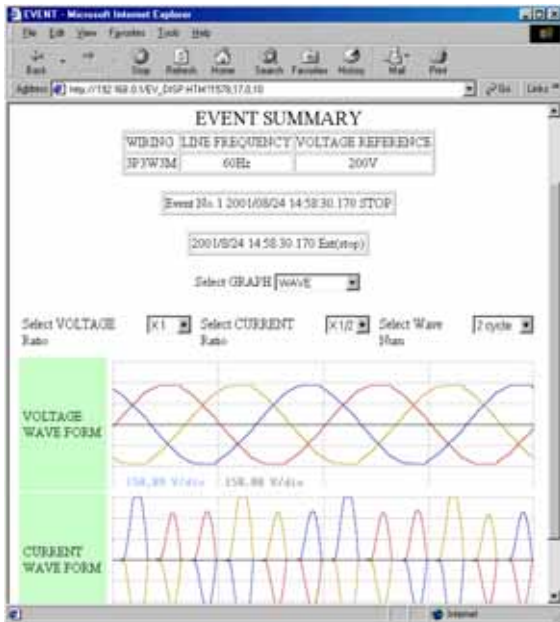

You can select the voltage, current, and waveform scales.

When a transient occurs, the transient waveform is displayed.

If multiple transients occur simultaneously, a link is displayed, and you can display the next waveform by following the link.

If you click on the waveform display area in the event waveform screen, text data is sent from the instrument.

MS-Excel starts automatically, and you can create graphs using the text data for the voltage or current waveform that you clicked.

Event Vector Screen

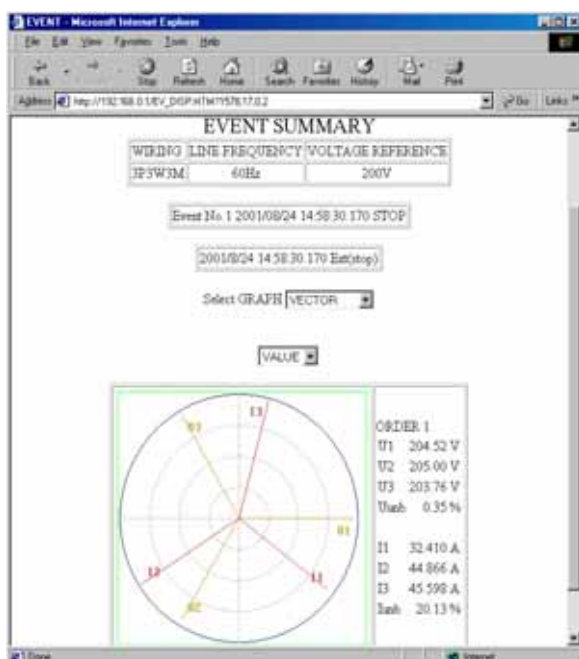

The graph's Y-axis is set to LOG. You can select the numeric display.

Event Harmonic Bar Graph Screen



You can select the display channel, numeric display, and order number.

Creating Reports

You can select the display channel, numeric display, and order number.

When using Internet Explorer as the Internet browser in the event details screen, you can create reports using MS-Word.

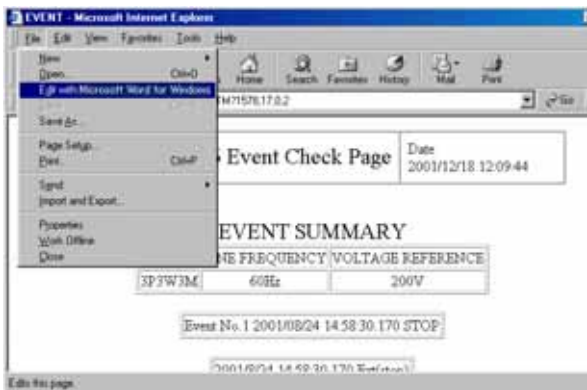

When the Internet Explorer HTML editor is set to Word:

Displays the HTTP server function's event list screen.

Select [**Edit with Microsoft Word for Windows**] from the [**File**] menu or toolbar.

MS-Word starts, and the data displayed in Internet Explorer is pasted into MS-Word.

You can edit the data in MS-Word, and use it to create an "event report."

Note: MS-Word 97 or later must be installed on your computer.

To set the Internet Explorer HTML editor to Word:

Select [**Internet Options**] on Internet Explorer's [**Tools**] menu.

On the [**Programs**] tab in the window that opened, select [**Microsoft Word for Windows**] in [**HTML editor**].

System Setting Screen



Options can be selected in **[SYSTEM]** – **[MAIN]**. The event settings can be made. However, interface settings, text save option selections, and event settings cannot be made.

Click setting items on the left side of the screen to display them on the right.

Start and finish measurement screen

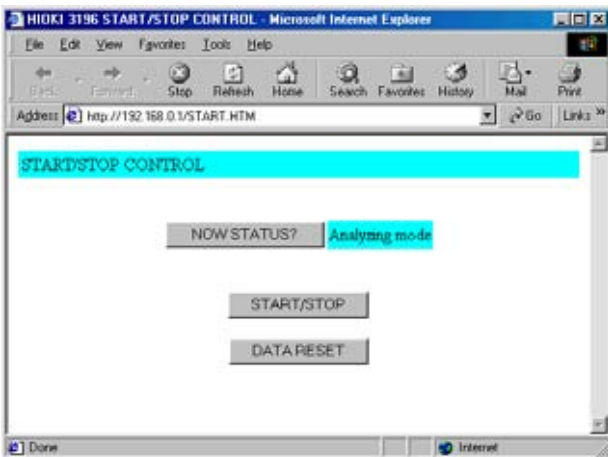

This screen allows you to start and stop measurement, and execute the data reset control for the instrument.

You can also display the current measurement status.

Specifications *Chapter 12*

12.1 Product Specifications

The specifications below apply to the 3196 POWER QUALITY ANALYZER.
For the product specifications of the EN50160, see the Instruction Manual for EN50160.

Environmental and Safety Specifications

Operating environment	Indoors, altitude up to 2000 m (6562-ft.)
Storage temperature and humidity	-20°C to 50°C (-4°F to 122°F), 80% RH or less (no condensation)
Operating temperature and humidity	0°C to 40°C (32°F to 104°F), 80% RH or less (non-condensating) In the temperature range -10°C to 0°C(14°F to 32°F), battery pack and PC card use are not supported. The LCD and accuracy are also not guaranteed.
Maximum input voltage (50/60 Hz)	Voltage inputs: 780 Vrms, 1103 V peak value Current inputs: 1.7 Vrms, 2.4 V peak value
Maximum rated voltage to earth	Voltage input terminals: 600 Vrms(50/60 Hz)
Dielectric strength (50 Hz for 1 min.)	5.55 kVrms for one minute (current sensitivity 1 mA) Between voltage and clamp input terminals, between voltage input terminals and instrument case, between voltage input terminals U1 to U3 and U4
Enclosure protection	IP30 (per EN60529)
Applicable Standards	Safety EN61010-1:2001 Voltage Input: Pollution Degree 2, Measurement Category III (anticipated transient overvoltage 6000V) EMC EN61326:1997+A1:1998+A2:2001 Class A EN61000-3-2:2000 EN61000-3-3:1995+A1:2001

Input Specifications

Measurement line type	One single-phase 2-wire (1P2W), single-phase 3-wire (1P3W), three-phase 3-wire (3P3W2M,3P3W3M) or three-phase 4-wire (3P4W) plus one extra input channel
Input channels	Voltage: Four channels U1 to U4 (extra channel U4 can measure AC or DC) Current: Four channels I1 to I4
Input methods	Voltage: Isolated inputs and differential operation Between U1,U2 and U3: these channels are not isolated from one another Between U1 to U3 and U4: channel U4 is isolated Current: input is isolated by the clamp-on sensor (voltage input)
Input resistance (50/60 Hz)	Voltage: 4 M Ω \pm 10% (differential input) Current: 200 k Ω \pm 10%
Measurement method	Simultaneous digital sampling of voltage and current PLL synchronization (during instantaneous low period of PLL synchronization source, switches to a fixed clock, with no sampling gap during switching)
PLL synch channel source	One of voltages U1, U2 or U3
PLL synch frequency range	42.5 Hz to 69 Hz, 360 to 440 Hz
Sampling frequency	For calculations (including DC measurements): 256 per cycle (at 50Hz or 60 Hz) 256 per 8 cycles (at 400 Hz) For harmonic and inter-harmonic analysis: 2048 per 10 cycles (50Hz) 2048 per 12 cycles (60Hz) 2048 per 80 cycles (400 Hz, harmonics only) For transient overvoltage (impulse): 2 MHz
A/D converter resolution	For calculations (including DC measurements): 16 bits For transient overvoltage (impulse): 12 bits
Compatible clamp sensors	0.5 Vrms output or more for full-scale current (0.5 Vrms recommended) Output-to-input ratios of 0.1, 1, 10 or 100 mV/A

Basic Specifications

Backup lithium battery life	Lithium battery to back up clock and settings, approx. 10 years (reference at 23°C, 73°F)
Clock functions	Auto calendar, auto leap year, 24-hour clock
Real-time clock accuracy	\pm 0.3 s/day or better (instrument on), \pm 3 s/day or better (instrument off)
Internal memory data capacity	13 MB
Maximum recording period	1 month (when using internal memory)
Maximum recordable events	100 events (when using the internal memory) (when using the PC card, up to 1000 events)
External control terminals	External event input, external event output
Power supply	9458 AC ADAPTER (SINO-AMERICAN SA 60-12 V) (12 VDC \pm 5%, 4.5 A) Rated voltage: 100 to 240 VAC (a change in voltage of \pm 10% taken into consideration), 50/60 Hz, maximum rated current: 1.2 A 9459 BATTERY PACK(Sanyo 6HR-AU Ni-MH) for backup during power off
Recharge function	Using the 9458 AC ADAPTER or 9459 BATTERY PACK to recharge while the 3196 is operating.

Basic Specifications

Maximum rated power	40 VA
Continuous battery operation time	Approx. 30 minutes with the 9459 BATTERY PACK (fully charged, 23°C, 73°F)
Dimensions	Approx. 298W x 215H x 67D mm (not including protrusions) (11.73"W x 8.46"H x 2.64"D)
Mass	Approx. 2.0 kg (70.5 oz) (without the battery pack), (mass of battery pack: approx. 250 g (8.8 oz))
Power quality conforming standard	IEEE1159, EN50160:1999, IEC61000-4-30:2003

Display Specifications

Display language	English, German, French, Italian, Spanish, Chinese (Simplified), or Japanese
Display device	6.4-inch TFT color LCD (640 × 480 pixels)
Dot pitch	0.202 (V) mm × 0.202 (H) mm (0.01"V × 0.01"H)

External Interface Specifications

PC Card Interface

Slot	TYPE II conforming to the PCMCIA/JEIDA PC Card Standard x 1 base
Supported cards	Flash ATA cards (at least 13 MB)
Supported storage capacity	528 MB
Data format	MS-DOS
Recording contents	Setting files, binary, text and screen image data

RS-232C Interface

Compliant standards	RS-232C EIA RS-232C, CCITT V.24, JIS X5101
Connector	One 9-pin D-sub
Connection devices	Printer, modem, or GPS Box
Communication protocols	PPP or TCP/IP (modem only)
Print function	Hard copy

LAN Interface

Connector	10Base-T, RJ-45 connector x 1
Communication protocols	Ethernet, TCP/IP

Accessories and Options

Accessories	<p>9438-02 VOLTAGE CORD 1 set: 8 cords (red, yellow, blue, and gray (one each), and 4 black cords)</p> <p>9458 AC ADAPTER 1 (The power cord can be selected in country specifications.)</p> <p>9459 BATTERY PACK (NiMH, 7.2 V/2700 mAh) Strap..... 1 Quick Start Manual..... 1 (booklet) Instruction Manual for EN50160.... 1 (booklet) CD-R 1 disc (Instruction Manual, Instruction Manual for EN50160, Down96 Data Download application software)</p> <p>LAN connector cover..... 1 Input cord label..... 1</p>
Options	<p>9661 CLAMP ON SENSOR (500 A rms rating) voltage output type 9660 CLAMP ON SENSOR (100 A rms rating) voltage output type 9667 FLEXIBLE CLAMP ON SENSOR (500 A rms, 5000 A rms rating) voltage output type 9669 CLAMP ON SENSOR (1000 A rms rating) voltage output type 9694 CLAMP ON SENSOR (5 A rms rating) voltage output type 9695-02 CLAMP ON SENSOR (50 A rms rating) voltage output type 9695-03 CLAMP ON SENSOR (100 A rms rating) voltage output type 9290 CLAMP ON ADAPTER 9219 CONNECTION CABLE (for Model 9695-02 and Model 9695-03)</p> <p>9458 AC ADAPTER 9459 BATTERY PACK</p> <p>9670 PRINTER (BL-80RS II made by SANEI ELECTRIC INC.) 9671 AC ADAPTER (for the 9670) (BL-100W made by SANEI ELECTRIC INC.) 9638 RS-232C CABLE (for the printer) 9237 RECORDING PAPER (80 mm x 25 m, 4 rolls) XD112 GPS BOX (assembled after receiving the order) 9624 PQA-HiVIEW (PC application software) 9624-10 PQA-HiVIEW PRO (PC application software)</p> <p>9339 CARRYING CASE (soft type, storage room for the voltage cord and clamp-on sensor) 9340 CARRYING CASE (hard type, storage room for the voltage cord and clamp-on sensor)</p> <p>9264-01 WIRING ADAPTER (for three-phase 3-wire (3P3W3M) voltage) 9264-02 WIRING ADAPTER (for three-phase 4-wire voltage)</p> <p>9726 PC CARD 128M (128MB compact flash card + adapter) 9727 PC CARD 256M (256MB compact flash card + adapter) 9728 PC CARD 512M (512MB compact flash card + adapter)</p> <p>9642 LAN CABLE</p>

12.2 Measurement Specifications

Measurements

Items detected at 2 MHz sampling without a gap

Item	Variable	1P2W	1P3W/ 3P3W2M	3P3W3M	3P4W	MAX/MIN/AVE
Transient overvoltage (impulse)	Utran	1,4	1, 2, 4	1, 2, 3, 4	1, 2, 3, 4	

When measuring at 50 Hz or 60 Hz, items measured in half cycles (calculates one waveform overlapped by half a wave) without gaps

When measuring at 400 Hz, items measured in a wave without gaps

Item	Variable	1P2W	1P3W/ 3P3W2M	3P3W3M	3P4W	MAX/MIN/AVE
Voltage swell	Uswell	1	1, 2	1, 2, 3	1, 2, 3	
Voltage dip (sag)	Udip	1	1, 2	1, 2, 3	1, 2, 3	
Voltage interruption	UInterruption	1	1, 2	1, 2, 3	1, 2, 3	
RMS voltage value (one wave shifted over half a wave)	U	1	1, 2	1, 2, 3	1, 2, 3	
Voltage fluctuation	ΔU	1	1, 2	1, 2, 3	1, 2, 3	
Instantaneous flicker	S(t)	1	1, 2	1, 2, 3	1, 2, 3	

Items measured every 200 ms (about once every 10 cycles at 50 Hz, every 12 cycles at 60 Hz, or every 80 cycles at 400 Hz) without a gap

Item	Variable		1P2W	1P3W/ 3P3W2M	3P3W3M	3P4W	MAX/MIN/ AVE
Voltage frequency	Freq		PLL source	PLL source	PLL source	PLL source	*
Voltage waveform peak (\pm)	Upeak		1,4	1, 2, 4	1, 2, 3, 4	1, 2, 3, 4	
Current waveform peak (\pm)	Ipeak		1,4	1, 2, 4	1, 2, 3, 4	1, 2, 3, 4	
RMS voltage value	Urms	LINE- LINE/ PHASE-N	1,4	1, 2, 4, ave	1, 2, 3, 4, ave	1, 2, 3, 4, ave	*
RMS current value	Irms		1,4	1, 2, 4, ave	1, 2, 3, 4, ave	1, 2, 3, 4, ave	*
Active power	P		1	1, 2, sum	1, 2, 3, sum	1, 2, 3, sum	*
Apparent power	S		1	1, 2, sum	1, 2, 3, sum	1, 2, 3, sum	*
Reactive power	Q		1	1, 2, sum	1, 2, 3, sum	1, 2, 3, sum	*
Power factor/displacement power factor	PF/DPF		1	1, 2, sum	1, 2, 3, sum	1, 2, 3, sum	*
Voltage unbalance factor	Uunb		-	-	sum	sum	*
Current unbalance factor	Iunb		-	-	sum	sum	*
Harmonic voltage (1st to 50th orders)	Uharm	RMS/%	1,4	1, 2, 4	1, 2, 3, 4	1, 2, 3, 4	*
Harmonic current (1st to 50th orders)	Iharm	RMS/%	1,4	1, 2, 4	1, 2, 3, 4	1, 2, 3, 4	*
Harmonic power (1st to 50th orders)	Pharm	RMS/%	1	1, 2, sum	sum	1, 2, 3, sum	*
Inter-harmonic voltage (orders 0.5 to 49.5)	Uharm-i	RMS/%	1,4	1, 2, 4	1, 2, 3, 4	1, 2, 3, 4	*
Inter-harmonic current (orders 0.5 to 49.5)	Iharm-i	RMS/%	1,4	1, 2, 4	1, 2, 3, 4	1, 2, 3, 4	*
Harmonic voltage phase angle (1st to 50th orders)	θ uharm		1,4	1, 2, 4	1, 2, 3, 4	1, 2, 3, 4	

12.2 Measurement Specifications

Items measured every 200 ms (about once every 10 cycles at 50 Hz, every 12 cycles at 60 Hz, or every 80 cycles at 400 Hz) without a gap

Item	Variable		1P2W	1P3W/ 3P3W2M	3P3W3M	3P4W	MAX/MIN/ AVE
Harmonic current phase angle (1st to 50th orders)	θ_{harm}		1,4	1, 2, 4	1, 2, 3, 4	1, 2, 3, 4	
Harmonic voltage-current phase difference (1st to 50th orders)	θ_{harm}		1	1, 2, sum	sum	1, 2, 3, sum	*
Total harmonic voltage distortion factor	Uthd	-F/-R	1,4	1, 2, 4	1, 2, 3, 4	1, 2, 3, 4	*
Total harmonic current distortion factor	Ithd	-F/-R	1,4	1, 2, 4	1, 2, 3, 4	1, 2, 3, 4	*
Total inter-harmonic voltage distortion factor	Uthd-i	-F/-R	1,4	1, 2, 4	1, 2, 3, 4	1, 2, 3, 4	*
Total inter-harmonic current distortion factor	Ithd-i	-F/-R	1,4	1, 2, 4	1, 2, 3, 4	1, 2, 3, 4	*
K factor	KF		1,4	1, 2, 4	1, 2, 3, 4	1, 2, 3, 4	*

Items measured in 1-minute intervals without a gap

Item	Variable		1P2W	1P3W/ 3P3W2M	3P3W3M	3P4W	MAX/MIN/ AVE
ΔV_{10} flicker Select a channel to calculate	ΔV_{10}		1	1, 2	1, 2, 3	1, 2, 3	

Items measured in 10-minute intervals without a gap

Item	Variable		1P2W	1P3W/ 3P3W2M	3P3W3M	3P4W	MAX/MIN/ AVE
Short interval IEC voltage flicker	Pst		1	1, 2	1, 2, 3	1, 2, 3	

Items measured in 2-hour intervals without a gap

Item	Variable		1P2W	1P3W/ 3P3W2M	3P3W3M	3P4W	MAX/MIN/ AVE
Long interval IEC voltage flicker	Plt		1	1, 2	1, 2, 3	1, 2, 3	

*: Indicates that you can display the MAX, MIN, and AVE (all three) for the MAX/MIN/AVE interval.

When CH4 is set to AC or DC, all of CH4 is displayed. (However, the 0 order of harmonics is not displayed.)

When CH4 is off, CH4 is not displayed. (However, the waveform display is displayed.)

U, ΔU , or S(t) is measured, depending on which is selected.

ΔV_{10} or Pst/Plt is measured, depending on which is selected.

- When measuring at 400 Hz, the following measurements are made up to the 10th harmonic order: harmonic voltage, current and power; harmonic voltage phase angle, harmonic current phase angle and harmonic voltage/current phase difference.
- When measuring at 400 Hz, the following measurements are not possible: instantaneous flicker value (s(t)), inter-harmonic voltage and current, integrated inter-harmonic voltage distortion, integrated inter-harmonic current, ΔV_{10} flicker and IEC flicker.

Conditions of Guaranteed Accuracy

Conditions of Guaranteed Accuracy	After 30 min warm-up, however, when measuring AC voltage; sine-wave input, PF=1, synchronized PLL
Temperature and humidity for guaranteed accuracy	23±5°C(73±9°F), 80% RH or less (applies to all specifications unless otherwise noted)
Guaranteed accuracy period	6 months
Fundamental waveform range for guaranteed accuracy	42.5 to 69 Hz (360 to 440 Hz for 400 Hz measurements, although guaranteed accuracy is only for separately conducted shipping tests)
Display area for guaranteed accuracy	Effective measurement area

Indicator

Total display area	0.15 to 130% of selected range (RMS voltage value, RMS current value, effective power, apparent power, reactive power, power factor) Display is suppressed to zero when less than 0.15%. 0.3 to 130% of selected range (DC voltage) Display is suppressed to zero when less than 0.3%. 0 to 130% of selected range (measurement items other than the above)
Effective measurement area	1 to 110% of selected range

Miscellaneous Measurement Items

(for all calculation items, there are no gaps of measurements)

RMS Voltage

Measurement method	True RMS type Measurement at 256 points per cycle about once every 10 cycles at 50 Hz or every 12 cycles at 60 Hz (approximately every 200 ms). Measurement at 256 points per 8 cycles about once every 80 cycles at 400 Hz (approximately every 200 ms).
Display item	RMS voltage value for each channel or AVE (average) RMS voltage value for multiple channels (For details, see the formula.(page 200))
Display conversion function	Three-phase 3-wire (3P3W3M): Δ (LINE-LINE, line-to-line voltage)-Y (PHASE-N, phase-to-neutral voltage) conversion (The central point is calculated as the center.) Three-phase 4-wire: Y (phase-to-neutral voltage)-Δ(line-to-line voltage)conversion
Measurement range	CH1 to 3: 150.00/300.00/600.00 V rms CH4: 60.000/150.00/300.00/600.00 V rms CH4 (for DC measurement): ±60.000/600.00 V pk
Range selection	Manual range (Same operation switches the range for CH1 to 3.)
DC measurement	MEAN calculation
Measurement accuracy	AC: ±0.2% rdg. ±0.1% f.s. (50/60 Hz), ±0.2% rdg. ±0.6% f.s. (400 Hz) DC: ±0.3% rdg. ±0.4% f.s.
Crest factor	Less than 3 (for full-scale input)

RMS Current

Measurement method	True RMS type Measurement at 256 points per cycle about once every 10 cycles at 50 Hz or every 12 cycles at 60 Hz (approximately every 200 ms). Measurement at 256 points per 8 cycles about once every 80 cycles at 400 Hz (approximately every 200 ms).
Item	The RMS current value for each channel or the AVE (average) RMS current value for multiple channels (For details, see the formula.(page 201))
Measurement range	CH1 to 4 When using a 0.1 mV/A sensor..... 500.00A/5000.0 A rms When using a 1 mV/A sensor, 9661..... 50.000A/500.00 A rms When using a 1 mV/A sensor, 9660..... 50.000A/100.00 A rms When using a 10 mV/A sensor, 9694..... 5.0000A/50.000 A rms When using a 100 mV/A sensor..... 500.00 mA/5.0000 A rms When using a 9667sensor, 5000 A range..... 500.00A/5.0000 kA rms When using a 9667sensor, 500 A range..... 50.000A/500.00 A rms When using a 9669 sensor 100.00A/1.0000 kA rms
Range selection	Manual range (Same operation switches the range for CH1 to 3.)
Measurement accuracy	$\pm 0.2\%$ rdg. $\pm 0.1\%$ f.s. + clamp sensor specification accuracy (50/60 Hz) $\pm 0.2\%$ rdg. $\pm 0.6\%$ f.s. + clamp sensor specification accuracy (400 Hz)
Crest factor	Less than 4 (for full-scale input)

Transient Overvoltage (impulse)

Measurement method	For detection, samples at 2 MHz are compared with calculation samples
Measurement range	CH1 to 4: ± 2000 V pk
Displayed items	Peak voltage: This value exceeds the threshold and can be up to the maximum value. Period: Period threshold is exceeded (max. 4 ms)
Minimum detectable duration	0.5 μ s
Measurement accuracy	$\pm 5.0\%$ rdg. ± 20 V (Conforms to 1000 V/DC or 700 V rms/100 kHz.)
Frequency range	DC to 200 kHz (-3 dB) (Conforms to 20 V rms)
Restrictions on saving waveforms	Saves waveforms that have a maximum transient overvoltage value (absolute value) within the basic voltage wave. (Waveforms in which the peak point is the center.)

RMS Voltage (value calculated for one waveform shifted over half a wave)

Measurement method	True RMS type Data samples of each half of one cycle (256 points) of the voltage waveform are overlapped, and the RMS voltage is obtained by calculating from one half cycle. (the line-to-line voltage is used for three-phase 3-wire (3P3W3M) systems, and the phase-to-neutral voltage is used for three-phase 4-wire systems) When measuring at 400 Hz, calculation is performed by averaging the squares of the sample data consisting of 256 points over 8 cycles of a waveform.
Limitation	At 400 Hz, the measurement values recorded for the event voltage fluctuation graph are maximum and minimum values of RMS voltage for each cycle.

Voltage Swell

Displayed items	Swell amplitude and duration
Threshold and hysteresis	% of basic voltage
Voltage swell height	swell to (threshold)% When measuring at 50 Hz or 60 Hz, if the RMS voltage (value calculated for one waveform shifted over half a wave) exceeds the threshold in the right direction, the swell is detected and the threshold height displayed. When measuring at 400 Hz, if the maximum of four RMS voltage values (400 Hz, single-cycle calculation) that exist within 20 ms exceeds the threshold in the positive direction, swell is detected at the threshold amplitude.
Voltage swell interval	The interval from the time of swell is detected until the threshold minus the hysteresis is exceeded in the wrong direction.

Voltage Dip

Displayed items	Dip depth and duration
Threshold and hysteresis	% of basic voltage
Voltage dip depth	dip to (threshold)% When measuring at 50 Hz or 60 Hz, if the RMS voltage (value calculated for one waveform shifted over half a wave) exceeds the threshold in the wrong direction, the dip is detected and the threshold depth displayed. When measuring at 400 Hz, if the minimum of four RMS voltage values (400 Hz, single-cycle calculation) that exist within 20 ms exceeds the negative threshold, dip is detected at the threshold amplitude
Voltage dip interval	The interval from time the dip is detected until the threshold added the hysteresis is exceeded in the right direction.

Interruption

Display items	Interruption interval (and interruption depth)
Threshold and hysteresis	% of basic voltage
Interruption depth	Interruption to (threshold)% When measuring at 50 Hz or 60 Hz, if the RMS voltage (value calculated for one waveform shifted over half a wave) exceeds the threshold in the wrong direction, the interruption is detected and the threshold height displayed. When measuring at 400 Hz, if the minimum of four RMS voltage values (400 Hz, single-cycle calculation) that exist within 20 ms exceeds the negative threshold, interruption is detected at the threshold amplitude
Interruption interval	The interval from the time of interruption is detected until the threshold added the hysteresis is exceeded in the right direction.

Frequency

Measurement method	Reciprocal frequencies are sampled at 2 MHz about once every 10 cycles at 50 Hz or every 12 cycles at 60 Hz (approximately every 200 ms). Waveform consists of 256 points/8 cycles, measured every 80 cycles at 400 Hz (approx. 200 ms)
Measurement range	42.500 Hz to 69.000 Hz, 360 Hz to 440 Hz
Measurement range	99.999 Hz, 999.99 Hz
Measurement source	One of voltages U1, U2 or U3 (the same as the PLL synchronization source)

Frequency

Measurement accuracy	At 50/60 Hz measurement, Less than ± 10 mHz (For a sine wave input with a voltage range of 10% to 110%). At 400 Hz measurement, Less than ± 100 mHz (For a sine wave input with a voltage range of 30% to 110%).
----------------------	---

Voltage Waveform Peak

Measurement method	Waveform consists of 256 points/cycle, measured every 12 or 10 cycles at 50 or 60 Hz, respectively (approx. 200 ms) Waveform consists of 256 points/8 cycles, measured every 80 cycles at 400 Hz (approx. 200 ms) Maximum and minimum sampling points within 200 ms
Display items	Positive peak value and negative peak value
Measurement range	Area of the RMS voltage range to which the crest factor was added.

Current Waveform Peak

Measurement method	Waveform consists of 256 points/cycle, measured every 12 or 10 cycles at 50 or 60 Hz, respectively (approx. 200 ms) Waveform consists of 256 points/8 cycles, measured every 80 cycles at 400 Hz (approx. 200 ms) Maximum and minimum sampling points in 200 ms
Display items	Positive peak value and negative peak value
Measurement range	Area of the RMS current range to which the crest factor was added.

Active Power

Measurement method	Waveform consists of 256 points/cycle, measured every 12 or 10 cycles at 50 or 60 Hz, respectively (approx. 200 ms) Waveform consists of 256 points/8 cycles, measured every 80 cycles at 400 Hz (approx. 200 ms) Calculated by averaging sampled voltage and current waveform data
Display items	Active power of each channel and its sum for multiple channels. (For details, see the formula.(page 201))
Measurement range	Depends on the voltage \times current range combination. (See the power range configuration table (page 193).)
Measurement accuracy	At 50/60 Hz measurement, $\pm 0.2\%$ rdg. $\pm 0.1\%$ f.s. + clamp sensor specification accuracy (power factor = 1)(The total is the sum of the channels used.) At 400 Hz measurement, $\pm 0.4\%$ rdg. $\pm 0.6\%$ f.s. + clamp sensor specification accuracy (power factor = 1)(The total is the sum of the channels used.)
Power factor influence	$\pm 1.0\%$ rdg. (45 Hz to 66 Hz, power factor = 0.5) $\pm 4.0\%$ rdg. (360 Hz to 440 Hz, power factor = 0.5)
Polarity display	For influx (consumption) No symbol, For outflow (regenerative) "-"

Apparent Power

Measurement method	Calculated from RMS voltage U and RMS current I.
Display item	Apparent power of each channel and its sum for multiple channels. (For details, see the formula.(page 201))
Measurement range	Depends on the voltage \times current range combination. (See the power range configuration table (page 193).)
Measurement accuracy	± 1 dgt. for calculations derived from the various measurement values. (sum is ± 3 dgt.)
Polarity display	No polarity

Reactive Power

Measurement method	Calculated using apparent power S and active power P.
Display item	Reactive power of each channel and its sum for multiple channels. (For details, see the formula.(page 202))
Measurement range	Depends on the voltage x current range combination. (See the power range configuration table (page 193).)
Measurement accuracy	± 1 dgt. for calculations derived from the various measurement values. (sum is ± 3 dgt.)
Polarity display	For phase lag (LAG: current is slower than voltage): no symbol For lead phase (LEAD: current is faster than voltage): "-"

Power Factor

Measurement method	Calculated from RMS voltage U, RMS current I, and active power P.
Display item	Power factor of each channel or its sum for multiple channels. (For details, see the formula.(page 202))
Measurement range	-1.000 (lead) to 0.000 to +1.000 (lag)
Measurement accuracy	± 1 dgt. for calculations derived from the various measurement values. (sum value is ± 3 dgt.)
Polarity display	For phase lag (LAG: current is slower than voltage): no symbol For lead phase (LEAD: current is faster than voltage): "-"

Displacement Power Factor

Measurement method	Calculated from the phase difference between the fundamental voltage wave and the fundamental current wave.
Display item	Displacement power factor of each channel and its sum value for multiple channels. (For details, see the formula.(page 203))
Measurement range	-1.000 (lead) to 0.000 to +1.000 (lag)
Measurement accuracy	At 50/60 Hz measurement, $\pm 0.5\%$ rdg. $\pm 0.2\%$ f.s. ± 1 dgt. (sum value is ± 3 dgt.) At 400 Hz measurement, $\pm 0.5\%$ rdg. $\pm 0.6\%$ f.s. ± 1 dgt. (sum value is ± 3 dgt.)
Polarity display	For phase lag (LAG: current is slower than voltage): no symbol For lead phase (LEAD: current is faster than voltage): "-"

Voltage Unbalance Factor

Measurement method	Calculated using various components of the three-phase fundamental voltage wave (line-to-line voltage) for three-phase 3-wire (3P3W3M) and three-phase 4-wire connections. (For details, see the formula. (page 203))
Total display area	0.00% to 100.00%

Current Unbalance Factor

Measurement method	Calculated using various components of the three-phase fundamental current wave (line-to-line current) for three-phase 3-wire (3P3W3M) and three-phase 4-wire connections. (For details, see the formula. (page 204))
Display range	0.00% to 100.00%

K Factor (multiplication factor)

Measurement method	Calculated using the harmonic RMS current of the 2nd to 50th orders. (For details, see the formula. (page 206))
Display range	0.00 to 500.00

ΔU Voltage Fluctuation

Measurement method	Change in RMS voltage (When measuring at 50/60 Hz, each waveform calculation value is obtained from a shifted half cycle. When measuring at 400 Hz, each is obtained from one full cycle.) with respect to standard voltage
Display range	Nominal voltage

S(t) Instantaneous Flicker value

Measurement method	Per IEC61000-4-15
Weighting filters	230 V lamp 50 Hz system, 120 V lamp 60 Hz system

 ΔV_{10} Flicker

Measurement method	Calculated using the " ΔV_{10} perceived flicker curve" (page 210) ΔV_{10} is measured at 1 minute intervals without gaps. 100 V conversion value
Display item	ΔV_{10} measured at one minute intervals, average value for one hour, maximum value for one hour, fourth largest value for one hour, total (within the measurement interval) maximum value
Standard voltage	Automatic (using AGC)
Measurement accuracy	$\pm 4\% \text{rdg.} \pm 0.01 \text{V}$
Conditions of guaranteed accuracy	For 100 V RMS fundamental wave (50/60 Hz), 1 V RMS fluctuating voltage, and 10 Hz fluctuating frequency.

IEC Flicker: short interval flicker value P_{st} and long interval flicker value P_{lt}

Measurement method	Per IEC61000-4-15:1997+A1:2003 P _{st} is calculated after 10 minutes of continuous measurement and P _{lt} after 2 hours of continuous measurement. The 100 V lamp is per IEC SC77A National Committee, "IEC61000-4-15 Flickermeter Conformity Discussion Report for 100 Series Flicker Meter Ad-Hoc W/G"
Flicker range	Uses logarithms to divide 0.0001 to 10000 P.U. into 1024.
Flicker filter	100 V lamp, 120 V lamp, 230 V lamp
Measurement accuracy	P _{st} : $\pm 5\% \text{rdg.}$ (as set forth for IEC61000-4-15 performance testing) Valid for input ranging from 50 to 100% of the voltage measurement range

Harmonic Voltage, Current and Power (including fundamental waveform content)

Measurement method	Per IEC61000-4-7:2002 Harmonic voltage and harmonic current: After harmonic analysis is performed, the adjacent inter-harmonics component is added to the harmonics component of whole orders and displayed. Harmonic power: Displays the harmonic power of each channel and its sum for multiple channels. (For details, see the formula. (page 206))
Harmonic analysis window width	10 or 12 cycles for 50 or 60 Hz, respectively, 80 cycles for 400 Hz
Number of points in 1 window	2048 points
Harmonic analysis window	Rectangular
Harmonic analysis frequencies	1st to 50th orders (of 42.5- to 69-Hz fundamental waveform) 1st to 10th orders (of 360- to 440-Hz fundamental waveform)

Harmonic Voltage, Current and Power (including fundamental waveform content)

Measurement accuracy	<p>At 50/60 Hz:</p> <p>Harmonic voltage and harmonic current: 1st to 20th orders: $\pm 0.5\%$ rdg. $\pm 0.2\%$ f.s. 21st to 50th orders: $\pm 1.0\%$ rdg. $\pm 0.3\%$ f.s.</p> <p>Harmonic power: 1st to 20th orders: $\pm 0.5\%$ rdg. $\pm 0.2\%$ f.s. 21st to 30th orders: $\pm 1.0\%$ rdg. $\pm 0.3\%$ f.s. 31st to 40th orders: $\pm 2.0\%$ rdg. $\pm 0.3\%$ f.s. 41st to 50th orders: $\pm 3.0\%$ rdg. $\pm 0.3\%$ f.s.</p> <p>At 400 Hz:</p> <p>Harmonic voltage and harmonic current: 1st to 2nd orders: $\pm 0.5\%$ rdg. $\pm 0.2\%$ f.s. 3rd to 6th orders: $\pm 1.0\%$ rdg. $\pm 0.3\%$ f.s. 7th to 10th orders: $\pm 1.0\%$ rdg. $\pm 0.3\%$ f.s. $\pm 0.5 \times (k-6)\%$rdg. (k: harmonic orders)</p> <p>Harmonic power: 1st to 2nd orders: $\pm 0.5\%$ rdg. $\pm 0.2\%$ f.s. 3rd to 4th orders: $\pm 1.0\%$ rdg. $\pm 0.3\%$ f.s. 5th to 10th orders: $\pm 1.0\%$ rdg. $\pm 0.3\%$ f.s. $\pm 1.0 \times (k-4)\%$rdg. (k: harmonic orders)</p> <p>However, the clamp sensor's accuracy is added when calculating harmonic current and harmonic power.</p>
----------------------	--

Inter-Harmonic Voltage and Current

Measurement method	Per IEC61000-4-7:2002 After harmonic analysis, harmonic voltage and current are summed and displayed as inter-harmonic contents with the harmonic contents according to harmonic order
Harmonic analysis window width	10 or 12 cycles for 50 or 60 Hz, respectively
Number of points in 1 window	2048 points
Harmonic analysis window	Rectangular
Harmonic analysis frequencies	0.5 to 49.5 orders (of 42.5- to 69-Hz fundamental waveform)
Measurement accuracy	Unspecified

Harmonic Voltage/Current Phase Angle (including fundamental wave components)

Measurement method	After harmonic analysis, the harmonic phase angle components for whole orders are displayed. (Set the phase angle for the PLL source of the fundamental wave to 0° .)
Measurement accuracy	Not defined

Harmonic Voltage/Current Phase Difference (including fundamental wave components)

Measurement method	After harmonic analysis, the difference between harmonic voltage and current phase angles is displayed
Display items	Harmonic voltage-current phase difference for each channel and sum (total value for multiple channels) (For details, see the formula.(page 209))
Measurement accuracy	At 50/60 Hz: 1st to 3rd orders: $\pm 2^\circ$, 4th to 50th orders: $\pm(0.02^\circ \times k+2^\circ)$ (k: harmonic orders) At 400 Hz: 1st to 10th orders: $\pm(0.16^\circ \times k+2^\circ)$ (k: harmonic orders) However, clamp sensor accuracy is added.
Accuracy range	Harmonic voltage and current level for each order within 1% of the range.

Total Harmonic Voltage/Current Distortion Factor

Measurement display	THD-F (total harmonic distortion factor for the fundamental wave) THD-R (total harmonic distortion factor for the total harmonic including the fundamental wave)
---------------------	---

Total Inter-harmonic Voltage/Current Distortion Factor

Measurement display	THD-F (total inter-harmonic distortion factor for the fundamental wave) THD-R (total inter-harmonic distortion factor for the total harmonic including the fundamental wave)
---------------------	---

Other Characteristics

Frequency characteristic	69 Hz to 1 kHz: $\pm 3\%$ f.s. 1 kHz to 3 kHz: $\pm 10\%$ f.s. (RMS voltage, RMS current), $\pm 15\%$ f.s. (active power)
Temperature characteristic	AC: At 50/60 Hz measurement, within $\pm 0.03\%$ f.s./ $^\circ\text{C}$ At 400 Hz measurement, within $\pm 0.05\%$ f.s./ $^\circ\text{C}$ (from 0 to 18 $^\circ\text{C}$ and from 28 to 40 $^\circ\text{C}$) DC: Within $\pm 0.1\%$ f.s./ $^\circ\text{C}$ (from 0 to 18 $^\circ\text{C}$ and from 28 to 40 $^\circ\text{C}$)
Effect of common mode voltage	$\pm 0.2\%$ f.s. or less (600 Vrms, 50/60 Hz, between voltage input terminal and instrument case) $\pm 2\%$ f.s. or less (600 Vrms, 400 Hz, between voltage input terminal and instrument 1/4 \times 3/4)
Effect of external magnetic field	$\pm 1.5\%$ f.s. or less (in a magnetic field of 400 A/m rms, 50/60 Hz)

Power Range Configuration Tables

When using a 0.1 mV/A (5000A) sensor

Current range Voltage range	500.00 A	5000.0 A
150.00 V	75.000 k	750.00 k
300.00 V	150.00 k	1.5000 M
600.00 V	300.00 k	3.0000 M

When using a 9660 sensor

Current range Voltage range	50.000 A	100.00 A
150.00 V	7.5000 k	15.000 k
300.00 V	15.000 k	30.000 k
600.00 V	30.000 k	60.000 k

When using a 100 mV/A (5A) sensor

Current range Voltage range	500.00 mA	5.0000 A
150.00 V	75.000	750.00
300.00 V	150.00	1.5000 k
600.00 V	300.00	3.0000 k

When using a 9667 sensor 500A range

Current range Voltage range	50.000 A	500.00 A
150.00 V	7.500 k	75.000 k
300.00 V	15.000 k	150.00 k
600.00 V	30.000 k	300.00 k

When using a 1 mV/A (500A) sensor or 9661 sensor

Current range Voltage range	50.000 A	500.00 A
150.00 V	7.5000 k	75.000 k
300.00 V	15.000 k	150.00 k
600.00 V	30.000 k	300.00 k

When using a 10 mV/A (50A) sensor or 9694 sensor

Current range Voltage range	5.0000 A	50.000 A
150.00 V	750.00	7.5000 k
300.00 V	1.5000 k	15.000 k
600.00 V	3.0000 k	30.000 k

When using a 9667 sensor 5000A range

Current range Voltage range	500.00 A	5.0000 kA
150.00 V	75.000 k	750.00 k
300.00 V	150.00 k	1.5000 M
600.00 V	300.00 k	3.0000 M

When using a 9669 sensor

Current range Voltage range	100.00 A	1.0000 kA
150.00 V	15.000 k	150.00 k
300.00 V	30.000 k	300.00 k
600.00 V	60.000 k	600.00 k

Applies to the active power of each channel (unit W), apparent power (unit VA), and reactive power (unit var).

Event Specifications

Event contents	Various events, measurement start, measurement stop
Event detection method	Detects events with OR.
Measurement used for event detection	Interruption values of measurements (Inter-harmonics detection is not possible.) (Event detection for MAX, MIN, and AVE values is not possible.)

12.3 Setting Functions

System Settings

	CH1, 2, 3	CH4
Measured line	1P2W, 1P3W, 3P3W2M, 3P3W3M, 3P4W	AC, DC, and OFF
Clamp sensor ratings	0.1 mV/A, 1 mV/A, 10 mV/A, 100 mV/A	Same as CH1, CH2, and CH3.
Voltage range	150 V, 300 V, 600 V	For AC: 60 V, 150 V, 300 V, 600 V For DC: 60 V, 600 V
PT ratio	1, 60, 100, 200, 300, 600, 700, 1000, 2000, 2500, 5000, VARIABLE (0.01 to 9999.99)	Same as CH1, CH2, and CH3.
Current range	When using a 0.1 mV/A sensor: 500 A, 5000 A When using a 1 mV/A sensor: (9661): 50 A, 500 A (9660): 50 A, 100 A When using a 10 mV/A sensor: (9694): 5 A, 50 A When using a 100 mV/A sensor: 500 mA, 5 A When using a 9667 sensor: (5000 A range): 500 A, 5000 A (500 A range): 50 A, 500 A When using a 9669 sensor: 100 A, 1000 A	Same as CH1, CH2, and CH3.
CT ratio	1, 40, 60, 80, 120, 160, 200, 240, 300, 400, 600, 800, 1200, VARIABLE (0.01 to 9999.99)	Same as CH1, CH2, and CH3.
Measured line frequency	50/60 Hz	
PLL synchronization/Frequency source	Voltage: U1, U2, U3	
Measured RMS voltage selection	Phase-to-neutral voltage and line-to-line voltage	
Measured harmonic selection	RMS and % of fundamental (content percentage)	
Measured harmonic distortion factor selection	THD-F (basic wave standard)/THD-R (total harmonic value standard)	
Power factor selection	Power factor/Displacement power factor	
Flicker measurement selection	OFF/ Δ V10/ Pst,Plt	
Nominal voltage	100/ 101/ 110/ 120/ 200/ 202/ 208/ 220/ 230/ 240/ 277/ 346/ 380/ 400/ 415/ 480/ 600/ VARIABLE (50 to 600 V in 1 V increments)	
Voltage recording	Urms/ Δ U/ S(t)	
Flicker measurement CH	U1 to U3	
Filter	120 V lamp/ 230 V lamp	
EN50160	ON/ OFF	

Hardware Settings

Display language	English, German, French, Italian, Spanish, Japanese
Beep	ON/ OFF
Screen colors	COLOR 1 to 4, MONO
LCD backlight	ON/ Auto OFF (1 m, 5 m, 10 m, 30 m, 1 h)
Real-time settings	Year/month/day/hour/minute
System reset	You can reset the unit to its defaults with the system's reset procedure. (This does not reset the display language, clock, IP address, or subnet mask.)
Version information	Software version display
Timer interval	OFF, 1 m, 5 m, 10 m, 30 m, 1 h, 2 h
Timer	OFF/COPY/EVENT

Measurement Time Control Settings

Real time control	OFF (Manual) / ON (time settings)
Start and end time settings	year/month/day/hour/minute (24-hour clock)

Time Series Data Settings

Interval settings	1 s, 3 s, 15 s, 30 s, 1 m, 5 m, 10 m, 30 m, 1 h, 2 h
MAX/MIN/AVE settings	AVE value/(MAX value, MIN value, AVE value)
Recorded item settings	Pattern 1, Pattern 2, Pattern 3

1: Power/ 2: P&Harm/ 3: ALL DATA

Recorded item	Pattern	1	2	3
Voltage (one wave shifted over half a wave)		●	●	●
Frequency		●	●	●
RMS voltage value		●	●	●
RMS current value		●	●	●
Voltage waveform peak		●	●	●
Current waveform peak		●	●	●
Active power		●	●	●
Apparent power		●	●	●
Reactive power		●	●	●
Power factor/Displacement power factor		●	●	●
Voltage unbalance factor		●	●	●
Current unbalance factor		●	●	●

1: Power/ 2: P&Harm/ 3: ALL DATA

Recorded item	Pattern	1	2	3
Harmonic voltage		×	●	●
Harmonic current		×	●	●
Harmonic power		×	●	●
Harmonic voltage-current phase difference		×	●	●
Inter-harmonic voltage		×	×	●
Inter-harmonic current		×	×	●
Total harmonic voltage distortion factor		●	●	●
Total harmonic current distortion factor		●	●	●
Total inter-harmonic voltage distortion factor		×	×	●
Total inter-harmonic current distortion factor		×	×	●
K factor		●	●	●
Flicker (ΔV_{10} or Pst, PLt)		●	●	●

Data Save Settings (save methods for time series data and event data)

Data save area	Always saves data in the internal memory (when a PC card is connected, saves data on the PC card as well)
Settings when the data save area is full	STOP/ LOOP (When "LOOP" is set: Time series data in internal memory: first in first out, event data: the worst event data is overwritten)

External Interface Settings

RS-232C output point	printer/modem/OFF (The LAN may be used when modem is not set as the output point.)
RS-232C settings	Baud rate (bps): 9600, 19200, 38400, 57600, 115200 (Other settings are fixed, transfer method: asynchronous communication method, data length: 8 bits, parity check: none, stop bit: 1, flow control: off, delimiter: CR + LF)
Modem setting	Modem communication monitoring time: OFF/ 1min/ 5min/ 10min/ 30min
LAN settings	IP address: 3 characters.3 characters.3 characters.3 characters (*.*.*.*) Subnet mask: 3 characters.3 characters.3 characters.3 characters (*.*.*.*)

PC Card Settings

Auto-save settings	OFF, BINARY, TEXT
PC card access function	Load (BINARY only), Save (BINARY or TEXT), Delete, Initialize
TEXT content setting	Fundamental, power, and channel settings. Harmonics, maximum order number, and channel settings.

Repeated Recording Settings

Repeated recording settings	OFF/ 1 day/ 1 week
The number of repeated recording operations	1 to 99 times
Repeated recording function operable when MemoryFull:	LOOP, Auto Saves: Binary, and Time-Start: ON.

Event Settings

Item	Order selection ^{*1}	Measurement selection ^{*2}	Positive and negative ^{*3}	Channel selection ^{*4}	Threshold ^{*5}
Transient overvoltage			±	1,2,3 4	OFF 0 to 2000 V pk
Voltage swell				1,2,3 -	OFF 0 to 200%
Voltage dip				1,2,3 -	OFF 0 to 100%
Voltage interruption				1,2,3 -	OFF 0 to 100%
Voltage frequency			Approximately	PLL source -	OFF 0 to 30 Hz
Voltage waveform peak (±)			±	1,2,3 4	OFF 0 to 1800 V
Current waveform peak (±)			±	1,2,3 4	OFF 0 to 2000 A
RMS voltage value		Inter-phase/ line-to-line	Up and down sense	1,2,3 4	OFF 0 to 600 V rms 0 to 60 V rms
RMS current value				1,2,3 4	OFF 0 to 500 A RMS
Active power			±	1,2,3 sum	OFF 0 to 3 MW (9MW)
Apparent power				1,2,3 sum	OFF 0 to 3 MVA
Reactive power			±	1,2,3 sum	OFF 0 to 3 Mvar
Power factor/Displacement power factor		PF/DPF	±	1,2,3 sum	OFF 0 to 1
Voltage unbalance factor				- sum	OFF 0 to 100%
Current unbalance factor				- sum	OFF 0 to 100%
Harmonic voltage	1st to 50th orders	RMS/%		1,2,3 4	OFF 0 to 600 V/ 0 to 100%
Harmonic current	1st to 50th orders	RMS/%		1,2,3 4	OFF 0 to 5000 A/ 0 to 100%
Harmonic power	1st to 50th orders	RMS/%	±	1,2,3 sum	OFF 0 to 3 MW/ 0 to 100%
Harmonic voltage-current phase difference	1st to 50th orders		±	1,2,3 sum	OFF 0 to 180°
Total harmonic voltage dis- tortion factor		-F/-R		1,2,3 4	OFF 0 to 100%
Total harmonic current dis- tortion factor		-F/-R		1,2,3 4	OFF 0 to 500%
K factor				1,2,3 4	OFF 0 to 500
Harmonic voltage distortion				1,2,3 -	OFF 0 to 100%
External event				Input Terminal -	OFF None

*1: Settings can be made individually for each harmonic order.

*2: Measurement settings can be selected for each type of measurement (inter-phase or line-to-line, RMS or %, and -F or -R).

*3: Plus and minus (±) indicates that the threshold is specified as the absolute value. (Detects events using absolute values regardless of if they are positive or negative.)

*4: You can set the threshold of channels that are separate and not off. (However, only 1, 2, and 3 are common settings.)

*5: The recorded threshold is the value multiplied when the PT ratio and CT ratio are set. Hysteresis is set as a percentage of the threshold and for all measurements at once (default setting: 1%). However, it is fixed at 0.1 Hz.

Other Functions

Warning functions

Incorrect connection check	Connection diagram screen: Check that the connection and clamp sensor are not reversed. Connection check screen: Check the phase order.
Out of range	When the input exceeds the range by 130%, displays ---.---
Out of crest factor	When the input peak value of the waveform is 3 times the voltage range or 4 times the current range, displays Out of crest factor.
PLL unlock	When PLL lock is not selected during an interruption, the device switches to the fixed clock (without gaps), and PLL unlock is displayed for that duration.

Other functions

Display hold function	You can hold and release the displayed value by pressing the DATA HOLD key.
Key lock function	All key operations except the power switch operations are disabled.
Read settings function	Settings can be read using the internal memory or a Flash ATA card. Number of settings that can be saved in the internal memory: up to 10
External event input/output function	External event input External event input is possible for TTL low level (when the voltage drops to less than approximately 2.5 V or there is a short circuit) between the GND terminal and the EVENT IN terminal. External event output For TTL low output when each type of event occurs between the GND terminal and the EVENT OUT terminal.
LCD backlight auto-off function	The backlight automatically turns off after the set time elapses since the last key operation. After the backlight automatically turns off, the LCD lights automatically when you push any key (also effective in key lock).
Manual event function	An event can be manually generated by simultaneously pressing the ESC and EVENT keys.

HTTP server function

Description	Remote control application function Start and finish measurement control function System settings function Event list function (you can also display waveforms, vectors, and harmonics bar graphs for events) (you can convert event waveforms into text)
Connection method	LAN interface or RS-232C interface
Supported software	Internet Explorer 4 or later

EN50160 function

See the product specifications in the Instruction Manual for EN50160.

12.4 Formulae

Voltage dips, voltage swells, and interruptions U (V rms)

Single-phase 2-wire 1P2W	Single-phase 3-wire 1P3W	Three-phase 3-wire 3P3W2M	Three-phase 3-wire 3P3W3M	Three-phase 4-wire 3P4W
$U1$ $U_c = \sqrt{\frac{1}{M} \sum_{s=0}^{M-1} (U_{cs})^2}$	$U1$ $U2$	Line-to-line voltage $U_{12} = \sqrt{\frac{1}{M} \sum_{s=0}^{M-1} (U1s)^2}$ $U_{32} = \sqrt{\frac{1}{M} \sum_{s=0}^{M-1} (U2s)^2}$	Line-to-line voltage $U_{12} = \sqrt{\frac{1}{M} \sum_{s=0}^{M-1} (U1s)^2}$ $U_{23} = \sqrt{\frac{1}{M} \sum_{s=0}^{M-1} (U2s)^2}$ $U_{31} = \sqrt{\frac{1}{M} \sum_{s=0}^{M-1} (U3s)^2}$	Phase-to-neutral voltage $U1$ $U2$ $U3$
<ul style="list-style-type: none"> Calculate a single waveform that has been overlapped half a wave at 256 points/wave. (M=256) Search for voltage dips, voltage swells, and interruptions based on the above RMS voltage value. 				

c: measured channel M: number of samples per cycle s: number of sampling points

Voltage waveform peak Up (V peak)

Single-phase 2-wire 1P2W	Single-phase 3-wire 1P3W	Three-phase 3-wire 3P3W2M	Three-phase 3-wire 3P3W3M	Three-phase 4-wire 3P4W
U_{p1} U_{p4}	U_{p1} U_{p2} U_{p4}	U_{p12} U_{p32} U_{p4}	U_{p12} U_{p23} U_{p31} U_{p4}	U_{p12} U_{p23} U_{p31} U_{p4}
<ul style="list-style-type: none"> Calculate the maximum positive and negative voltage waveform peaks of all points about once every 10 cycles at 50 Hz or every 12 cycles at 60 Hz with a single wave (256 points). The voltage waveform peak for CH4 can be calculated regardless of the connection method. 				

c: measured channel M: number of samples per cycle s: number of sampling points

Current waveform peak Ip (Apeak)

Single-phase 2-wire 1P2W	Single-phase 3-wire 1P3W	Three-phase 3-wire 3P3W2M	Three-phase 3-wire 3P3W3M	Three-phase 4-wire 3P4W
I_{p1} I_{p4}	I_{p1} I_{p2} I_{p4}	I_{p1} I_{p2} I_{p4}	I_{p1} I_{p2} I_{p3} I_{p4}	I_{p1} I_{p2} I_{p3} I_{p4}
<ul style="list-style-type: none"> Calculate the maximum positive and negative current waveform peaks of all points about once every 10 cycles at 50 Hz or every 12 cycles at 60 Hz with a single wave (256 points). The current waveform peak for CH4 can be calculated regardless of the connection method. 				

c: measured channel M: number of samples per cycle s: number of sampling points

RMS voltage U (V rms)

Single-phase 2-wire 1P2W	Single-phase 3-wire 1P3W	Three-phase 3-wire 3P3W2M	Three-phase 3-wire 3P3W3M	Three-phase 4-wire 3P4W
$U1$ $U4$ $Uc = \sqrt{\frac{1}{M} \sum_{s=0}^{M-1} (Ucs)^2}$	$U1$ $U2$ $U4$	line-to-line voltage $U_{12} = \sqrt{\frac{1}{M} \sum_{s=0}^{M-1} (U1s)^2}$ $U_{32} = \sqrt{\frac{1}{M} \sum_{s=0}^{M-1} (U2s)^2}$ $U4$	Line-to-line voltage $U_{12} = \sqrt{\frac{1}{M} \sum_{s=0}^{M-1} (U1s)^2}$ $U_{23} = \sqrt{\frac{1}{M} \sum_{s=0}^{M-1} (U2s)^2}$ $U_{31} = \sqrt{\frac{1}{M} \sum_{s=0}^{M-1} (U3s)^2}$ $U4$	Phase-to-neutral voltage $U1$ $U2$ $U3$ $U4$
		Phase-to-neutral voltage <hr/>	Phase-to-neutral voltage $U_1 = \sqrt{\frac{1}{M} \sum_{s=0}^{M-1} \left(\frac{U1s - U3s}{3} \right)^2}$ $U_2 = \sqrt{\frac{1}{M} \sum_{s=0}^{M-1} \left(\frac{U2s - U1s}{3} \right)^2}$ $U_3 = \sqrt{\frac{1}{M} \sum_{s=0}^{M-1} \left(\frac{U3s - U2s}{3} \right)^2}$ $U4$	Line-to-line voltage $U_{12} = \sqrt{\frac{1}{M} \sum_{s=0}^{M-1} (U1s - U2s)^2}$ $U_{23} = \sqrt{\frac{1}{M} \sum_{s=0}^{M-1} (U2s - U3s)^2}$ $U_{31} = \sqrt{\frac{1}{M} \sum_{s=0}^{M-1} (U3s - U1s)^2}$ $U4$
	$U_{ave} = \frac{1}{2}(U1 + U2)$	Line-to-line voltage $U_{ave} = \frac{1}{2}(U_{12} + U_{32})$ Phase-to-neutral voltage <hr/>	Line-to-line voltage $U_{ave} = \frac{1}{3}(U_{12} + U_{23} + U_{31})$ Phase-to-neutral voltage $U_{ave} = \frac{1}{3}(U1 + U2 + U3)$	Phase-to-neutral voltage $U_{ave} = \frac{1}{3}(U1 + U2 + U3)$ Line-to-line voltage $U_{ave} = \frac{1}{3}(U_{12} + U_{23} + U_{31})$

- RMS voltage is calculated about once every 10 cycles at 50 Hz or every 12 cycles at 60 Hz with a single wave (256 points).
- Make the neutral point the center and calculate the phase-to-neutral voltage for three-phase 3-wire connections. The RMS voltage for CH4 can be calculated regardless of the connection method.
- Use the line-to-line voltage calculated for three-phase 3-wire and three-phase 4-wire connections to calculate $\Delta V10$. (See the formula for $\Delta V10$.)

c: measured channel M: number of samples s: number of sampling points

RMS current I (A rms)

Single-phase 2-wire 1P2W	Single-phase 3-wire 1P3W	Three-phase 3-wire 3P3W2M	Three-phase 3-wire 3P3W3M	Three-phase 4-wire 3P4W
I_1 I_4 $I_c = \sqrt{\frac{1}{M} \sum_{s=0}^{M-1} (I_{cs})^2}$	I_1 I_2 I_4	I_1 I_2 I_4	I_1 I_2 I_3 I_4	I_1 I_2 I_3 I_4
—————	$I_{ave} = \frac{1}{2}(I_1 + I_2)$	$I_{ave} = \frac{1}{2}(I_1 + I_2)$	$I_{ave} = \frac{1}{3}(I_1 + I_2 + I_3)$	$I_{ave} = \frac{1}{3}(I_1 + I_2 + I_3)$
<ul style="list-style-type: none"> Calculate RMS current about once every 10 cycles at 50 Hz and every 12 cycles at 60 Hz with a single wave (256 points). The RMS current for CH4 can be calculated regardless of the connection method. 				

c: measured channel M: number of samples s: number of sampling points

Active power P (W)

Single-phase 2-wire 1P2W	Single-phase 3-wire 1P3W	Three-phase 3-wire 3P3W2M	Three-phase 3-wire 3P3W3M	Three-phase 4-wire 3P4W
P_1 $P_c = \frac{1}{M} \sum_{s=0}^{M-1} (U_{cs} \times I_{cs})$	P_1 P_2	P_1 P_2	P_1 P_2 P_3	P_1 P_2 P_3
—————	$P_{sum} = P_1 + P_2$	$P_{sum} = P_1 + P_2$	$P_{sum} = P_1 + P_2 + P_3$	$P_{sum} = P_1 + P_2 + P_3$
<ul style="list-style-type: none"> Calculate active power about once every 10 cycles at 50 Hz or every 12 cycles at 60 Hz with a single wave (256 points). For three-phase 3-wire 3M and three-phase 4-wire connections, use phase-to-neutral voltage as the voltage waveform U_{cs}. Three-phase 3-wire 3M: $U_{1s} = (U_{1s} - U_{3s})/3$, $U_{2s} = (U_{2s} - U_{1s})/3$, and $U_{3s} = (U_{3s} - U_{2s})/3$ Polarity symbols for active power P indicate the power direction when power is being consumed (+P) and when power is being regenerated (-P). 				

c: measured channel M: number of samples s: number of sampling points

Apparent power S (VA)

Single-phase 2-wire 1P2W	Single-phase 3-wire 1P3W	Three-phase 3-wire 3P3W2M	Three-phase 3-wire 3P3W3M	Three-phase 4-wire 3P4W
S_1 $S_c = U_c \times I_c$ (When P >, make P = S.)	S_1 S_2	S_1 S_2	S_1 S_2 S_3	S_1 S_2 S_3
—————	$S_{sum} = S_1 + S_2$	$S_{sum} = \frac{\sqrt{3}}{2}(S_1 + S_2)$	$S_{sum} = S_1 + S_2 + S_3$	$S_{sum} = S_1 + S_2 + S_3$
<ul style="list-style-type: none"> For three-phase 3-wire 3M and three-phase 4-wire connections, use phase-to-neutral voltage for U_c. 				

c: measured channel M: number of samples s: number of sampling points

Reactive power Q (var)

Single-phase 2-wire 1P2W	Single-phase 3-wire 1P3W	Three-phase 3-wire 3P3W2M	Three-phase 3-wire 3P3W3M	Three-phase 4-wire 3P4W
Q_1 $Q_c = sic \sqrt{S_c^2 - P_c^2}$	Q_1 Q_2	Q_1 Q_2	Q_1 Q_2 Q_3	Q_1 Q_2 Q_3
—————	$Q_{sum} = Q_1 + Q_2$	$Q_{sum} = Q_1 + Q_2$	$Q_{sum} = Q_1 + Q_2 + Q_3$	$Q_{sum} = Q_1 + Q_2 + Q_3$

- The polarity symbol sic for reactive power Q indicates a LAG or LEAD in polarity; no symbol indicates a LAG, while the “-” symbol indicates a LEAD.
- Calculate the harmonic reactive power of each measured channel (c) using the polarity symbol sic, and attach the opposite symbol for fundamental wave reactive power (using k = 1 (1st order)). (See the harmonic reactive power formula.)

c: measured channel M: number of samples s: number of sampling points

Power factor PF

Single-phase 2-wire 1P2W	Single-phase 3-wire 1P3W	Three-phase 3-wire 3P3W2M	Three-phase 3-wire 3P3W3M	Three-phase 4-wire 3P4W
PF_1 $PF_c = sic \frac{P_c}{S_c}$	PF_1 PF_2	PF_1 PF_2	PF_1 PF_2 PF_3	PF_1 PF_2 PF_3
—————	$PF_{sum} = sisum \frac{P_{sum}}{S_{sum}}$	$PF_{sum} = sisum \frac{P_{sum}}{S_{sum}}$	$PF_{sum} = sisum \frac{P_{sum}}{S_{sum}}$	$PF_{sum} = sisum \frac{P_{sum}}{S_{sum}}$

- The polarity symbol si for power factors indicates a LEAD or LAG in polarity; no symbol indicates a LAG, while the “-” symbol indicates a LEAD.
- Calculate the harmonic reactive power using the polarity symbol sic and attach the symbol for the fundamental wave reactive power (using k = 1 (1st order) for each measured channel (c)).
- Calculate the harmonic reactive power using the polarity symbol sisum and attach the opposite symbol of the sum of the fundamental wave reactive power (using k = 1 (1st order)). (See the harmonic reactive power formula.)

c: measured channel, k: order for analysis

Displacement power factor DPF

Single-phase 2-wire 1P2W	Single-phase 3-wire 1P3W	Three-phase 3-wire 3P3W2M	Three-phase 3-wire 3P3W3M	Three-phase 4-wire 3P4W
DPF_1 $DPF_c = si_c \cos \theta_{c1} $	DPF_1 DPF_2	DPF_1 DPF_2	DPF_1 DPF_2 DPF_3	DPF_1 DPF_2 DPF_3
_____	$DPF_{sum} = sisum \frac{P_{sum1}}{S_{sum1}}$	$DPF_{sum} = sisum \frac{P_{sum1}}{S_{sum1}}$	$DPF_{sum} = sisum \frac{P_{sum1}}{S_{sum1}}$	$DPF_{sum} = sisum \frac{P_{sum1}}{S_{sum1}}$

- The polarity symbol *si* of power factors indicates a LEAD or LAG in polarity; no symbol indicates a LAG, while the “-” symbol indicates a LEAD.
- Calculate the harmonic reactive power using the polarity symbol *si_c* and attach the symbol for the fundamental wave reactive power (using *k* = 1 (1st order) for each measured channel (*c*)).
- Calculate the harmonic reactive power using the polarity symbol *sisum* and attach the opposite symbol for the sum of the fundamental wave reactive power (using *k* = 1 (1st order)). (See the harmonic reactive power formula.(page 206))
- θ_{c1} indicates the voltage-current phase difference for the fundamental wave. (See the voltage-current phase difference formula.(page 209))
- *P_{sum1}* indicates the total of fundamental wave power and the formula becomes *k* = 1 for the sum of harmonic power. (See the harmonic power formula.(page 206))
- *S_{sum1}* indicates the total of fundamental wave apparent power and can be searched for using the fundamental wave RMS voltage and fundamental wave RMS current. (For information on the formulae for harmonic voltage, harmonic current, and the sum of apparent power, see (page 204).)

c: measured channel, *k*: order for analysis

Voltage unbalance factor *U_{unb}* (%)

Single-phase 2-wire 1P2W	Single-phase 3-wire 1P3W	Three-phase 3-wire 3P3W2M	Three-phase 3-wire 3P3W3M	Three-phase 4-wire 3P4W
_____	_____	_____	$U_{unb} = \frac{\sqrt{1 - \sqrt{3 - 6\beta}}}{\sqrt{1 + \sqrt{3 - 6\beta}}} \times 100$ $\beta = \frac{U_{12}^4 + U_{23}^4 + U_{31}^4}{(U_{12}^2 + U_{23}^2 + U_{31}^2)^2}$	$U_{unb} = \frac{\sqrt{1 - \sqrt{3 - 6\beta}}}{\sqrt{1 + \sqrt{3 - 6\beta}}} \times 100$ $\beta = \frac{U_{12}^4 + U_{23}^4 + U_{31}^4}{(U_{12}^2 + U_{23}^2 + U_{31}^2)^2}$

- For U_{12} , U_{23} , and U_{31} , use the fundamental wave RMS voltage from the calculated harmonics results.
- Calculate the Discrete Fourier Transform of the harmonic RMS voltage at 2048 points (about once every 10 cycles at 50 Hz or every 12 cycles at 60 Hz).
- For three-phase 4-wire configurations, this is detected using phase-to-neutral voltage but can be converted and calculated using line-to-line voltage.

Current unbalance factor Iunb (%)

Single-phase 2-wire 1P2W	Single-phase 3-wire 1P3W	Three-phase 3-wire 3P3W2M	Three-phase 3-wire 3P3W3M	Three-phase 4-wire 3P4W
_____	_____	_____	$Iunb = \frac{\sqrt{1-\sqrt{3-6\beta}}}{\sqrt{1+\sqrt{3-6\beta}}} \times 100$ $\beta = \frac{I_{12}^4 + I_{23}^4 + I_{31}^4}{(I_{12}^2 + I_{23}^2 + I_{31}^2)^2}$	$Iunb = \frac{\sqrt{1-\sqrt{3-6\beta}}}{\sqrt{1+\sqrt{3-6\beta}}} \times 100$ $\beta = \frac{I_{12}^4 + I_{23}^4 + I_{31}^4}{(I_{12}^2 + I_{23}^2 + I_{31}^2)^2}$
<ul style="list-style-type: none"> • For I_{12}, I_{23}, and I_{31}, use the fundamental wave RMS current (line-to-line current) from the calculated harmonics results. • Calculate the Discrete Fourier Transform of harmonic RMS current at 2048 points (about once every 10 cycles at 50 Hz or every 12 cycles at 60 Hz). • For three-phase 3-wire and three-phase 4-wire configurations this is detected using phase current, but can be converted and calculated using line-to-line current. 				

Harmonic voltage Uk (V rms) (including adjacent inter-harmonics components)

Single-phase 2-wire 1P2W	Single-phase 3-wire 1P3W	Three-phase 3-wire 3P3W2M	Three-phase 3-wire 3P3W3M	Three-phase 4-wire 3P4W
U_{1k} U_{4k} $U'ck = \sqrt{(Uckr)^2 + (Ucki)^2}$ $Uck = \sqrt{\sum_{n=-1}^1 \left\{ U'_{c\left(\frac{10k+n}{10}\right)} \right\}^2}$	U_{1k} U_{2k} U_{4k}	U_{12k} U_{32k} U_{4k}	U_{12k} U_{23k} U_{31k} U_{4k}	U_{1k} U_{2k} U_{3k} U_{4k}
<ul style="list-style-type: none"> • Calculate the Discrete Fourier Transform of harmonic RMS voltage at 2048 points (about once every 10 cycles at 50 Hz or every 12 cycles at 60 Hz). • Indicates the results of the harmonic calculations of line-to-line voltage for three-phase 3-wire configurations and the results of harmonic calculations of phase-to-neutral voltage for three-phase 4-wire configurations. • For harmonic voltage content percentage, divide the fundamental wave voltage component by the harmonic voltage component of the specified order, then multiply by 100. • When using 60 Hz, the number "10" in the expression above is "12." 				

c: measured channel, k: order for analysis, r: resistance after FFT, i: reactance after FFT

Harmonic current Ik (A rms) (including adjacent inter-harmonic components)

Single-phase 2-wire 1P2W	Single-phase 3-wire 1P3W	Three-phase 3-wire 3P3W2M	Three-phase 3-wire 3P3W3M	Three-phase 4-wire 3P4W
I_{1k} I_{4k} $I'ck = \sqrt{(Ickr)^2 + (Icki)^2}$ $Ick = \sqrt{\sum_{n=-1}^1 \left\{ I'_{c\left(\frac{10k+n}{10}\right)} \right\}^2}$	I_{1k} I_{2k} I_{4k}	I_{1k} I_{2k} I_{4k}	I_{1k} I_{2k} I_{3k} I_{4k}	I_{1k} I_{2k} I_{3k} I_{4k}
<ul style="list-style-type: none"> • Calculate the Discrete Fourier Transform of harmonic RMS current at 2048 points (about once every 10 cycles at 50 Hz or every 12 cycles at 60 Hz). • For harmonic current content percentage, divide the fundamental wave current component by the harmonic current component of the specified order, then multiply by 100. • When using 60 Hz, the number "10" in the expression above is "12." 				

c: measured channel, k: order for analysis, r: resistance after FFT, i: reactance after FFT

Inter-harmonic voltage U_k (V rms)

Single-phase 2-wire 1P2W	Single-phase 3-wire 1P3W	Three-phase 3-wire 3P3W2M	Three-phase 3-wire 3P3W3M	Three-phase 4-wire 3P4W
U_{1k} U_{4k} $U'_{ck} = \sqrt{(U_{ckr})^2 + (U_{cki})^2}$ $U_{ck} = \sqrt{\sum_{n=-3}^3 \left\{ U'_{c\left(\frac{10k+n}{10}\right)} \right\}^2}$	U_{1k} U_{2k} U_{4k}	U_{12k} U_{32k} U_{4k}	U_{12k} U_{23k} U_{31k} U_{4k}	U_{1k} U_{2k} U_{3k} U_{4k}

- Calculate the Discrete Fourier Transform of harmonic RMS voltage at 2048 points (about once every 10 cycles at 50 Hz or every 12 cycles at 60 Hz).
- In the equation above, 3 and -3 are used at 50 Hz, and 4 and -4 are used at 60 Hz. $k = 0.5, 1.5, 2.5, 3.5, \dots$
- Indicates the results of the harmonic calculations of line-to-line voltage for three-phase 3-wire configurations and the results of harmonic calculations of phase-to-neutral voltage for three-phase 4-wire configurations.
- For inter-harmonic voltage content percentage, divide the fundamental wave voltage component by the inter-harmonic voltage component of the specified order, then multiply by 100.
- When using 60 Hz, the number "10" in the above expression is "12."

c: measured channel, k: order for analysis, r: resistance after FFT, i: reactance after FFT

Inter-harmonic current I_k (A rms)

Single-phase 2-wire 1P2W	Single-phase 3-wire 1P3W	Three-phase 3-wire 3P3W2M	Three-phase 3-wire 3P3W3M	Three-phase 4-wire 3P4W
I_{1k} I_{4k} $I'_{ck} = \sqrt{(I_{ckr})^2 + (I_{cki})^2}$ $I_{ck} = \sqrt{\sum_{n=-3}^3 \left\{ I'_{c\left(\frac{10k+n}{10}\right)} \right\}^2}$	I_{1k} I_{2k} I_{4k}	I_{1k} I_{2k} I_{4k}	I_{1k} I_{2k} I_{3k} I_{4k}	I_{1k} I_{2k} I_{3k} I_{4k}

- Calculate the Discrete Fourier Transform of harmonic RMS current at 2048 points (about once every 10 cycles at 50 Hz or every 12 cycles at 60 Hz).
- In the equation above, 3 and -3 are used at 50 Hz, and 4 and -4 are used at 60 Hz. $k = 0.5, 1.5, 2.5, 3.5, \dots$
- For inter-harmonic current content percentage, divide the fundamental wave current component by the inter-harmonic current component for the specified order, then multiply by 100.
- When using 60 Hz, the number "10" in the above expression is "12."

c: measured channel, k: order for analysis, r: resistance after FFT, i: reactance after FFT

Harmonic power Pk (W)

Single-phase 2-wire 1P2W	Single-phase 3-wire 1P3W	Three-phase 3-wire 3P3W2M	Three-phase 3-wire 3P3W3M	Three-phase 4-wire 3P4W
P_{1k} $P_{ck} = U_{ckr} \times I_{ckr} + U_{cki} \times I_{cki}$	P_{1k} P_{2k}	P_{1k} P_{2k}	$P_{1k} = \frac{1}{3}(U_{1kr} - U_{3kr}) \times I_{1kr} + \frac{1}{3}(U_{1ki} - U_{3ki}) \times I_{1ki}$ $P_{2k} = \frac{1}{3}(U_{2kr} - U_{1kr}) \times I_{2kr} + \frac{1}{3}(U_{2ki} - U_{1ki}) \times I_{2ki}$ $P_{3k} = \frac{1}{3}(U_{3kr} - U_{2kr}) \times I_{3kr} + \frac{1}{3}(U_{3ki} - U_{2ki}) \times I_{3ki}$	P_{1k} P_{2k} P_{3k}
_____	$P_{sumk} = P_{1k} + P_{2k}$	$P_{sumk} = P_{1k} + P_{2k}$	$P_{sumk} = P_{1k} + P_{2k} + P_{3k}$	$P_{sumk} = P_{1k} + P_{2k} + P_{3k}$

- Calculate the Discrete Fourier Transform of harmonic power (harmonic active power) at 2048 points for voltage and current (about once every 10 cycles at 50 Hz or every 12 cycles at 60 Hz).
- For harmonic power content percentage, divide the fundamental wave power component by the harmonic power component of the specified order, then multiply by 100.

c: measured channel, k: order for analysis, r: resistance after FFT, i: reactance after FFT

Harmonic reactive power Qk (var) (only for use with internal calculation)

Single-phase 2-wire 1P2W	Single-phase 3-wire 1P3W	Three-phase 3- wire 3P3W2M	Three-phase 3-wire 3P3W3M	Three-phase 4-wire 3P4W
Q_{1k} $Q_{ck} = U_{ckr} \times I_{cki} - U_{cki} \times I_{ckr}$	Q_{1k} Q_{2k}	Q_{1k} Q_{2k}	$Q_{1k} = \frac{1}{3}(U_{1kr} - U_{3kr}) \times I_{1kr} - \frac{1}{3}(U_{1ki} - U_{3ki}) \times I_{1ki}$ $Q_{2k} = \frac{1}{3}(U_{2kr} - U_{1kr}) \times I_{2kr} - \frac{1}{3}(U_{2ki} - U_{1ki}) \times I_{2ki}$ $Q_{3k} = \frac{1}{3}(U_{3kr} - U_{2kr}) \times I_{3kr} - \frac{1}{3}(U_{3ki} - U_{2ki}) \times I_{3ki}$	Q_{1k} Q_{2k} Q_{3k}
_____	$Q_{sumk} = Q_{1k} + Q_{2k}$	$Q_{sumk} = Q_{1k} + Q_{2k}$	$Q_{sumk} = Q_{1k} + Q_{2k} + Q_{3k}$	$Q_{sumk} = Q_{1k} + Q_{2k} + Q_{3k}$

- Calculate the Discrete Fourier Transform of harmonic reactive power at 2048 points for voltage and current (about once every 10 cycles at 50 Hz or every 12 cycles at 60 Hz).

c: measured channel, k: order for analysis, r: resistance after FFT, i: reactance after FFT

K factor KF

Single-phase 2-wire 1P2W	Single-phase 3-wire 1P3W	Three-phase 3-wire 3P3W2M	Three-phase 3-wire 3P3W3M	Three-phase 4-wire 3P4W
KF_1 KF_4 $KFC = \frac{\sum_{k=1}^{50} (k^2 \times I_{ck}^2)}{\sum_{k=1}^{50} I_{ck}^2}$	KF_1 KF_2 KF_4	KF_1 KF_2 KF_4	KF_1 KF_2 KF_3 KF_4	KF_1 KF_2 KF_3 KF_4

- The K factor is also called the multiplication factor, and indicates the power loss using the harmonic RMS current for the electrical transformer.
- Calculate the Discrete Fourier Transform of harmonic RMS current at 2048 points (about once every 10 cycles at 50 Hz or every 12 cycles at 60 Hz).

c: measured channel, k: order for analysis

Total harmonic voltage distortion factor THDUF (%)

Single-phase 2-wire 1P2W	Single-phase 3-wire 1P3W	Three-phase 3-wire 3P3W2M	Three-phase 3-wire 3P3W3M	Three-phase 4-wire 3P4W
$THDUF1$ $THDUF4$ $THDUF_c = \frac{\sqrt{\sum_{k=2}^K (U_{ck})^2}}{U_{c1}} \times 100$	$THDUF1$ $THDUF2$ $THDUF4$	$THDUF12$ $THDUF32$ $THDUF4$	$THDUF12$ $THDUF23$ $THDUF31$ $THDUF4$	$THDUF1$ $THDUF2$ $THDUF3$ $THDUF4$
<ul style="list-style-type: none"> • Calculate the Discrete Fourier Transform of harmonic RMS voltage at 2048 points (about once every 10 cycles at 50 Hz or every 12 cycles at 60 Hz). • Three-phase 3-wire indicates the result of harmonic calculation with line-to-line voltage. • In the equation above, K indicates the total of orders analyzed. • Select THDUF or THDUR to calculate the total harmonic voltage distortion factor. 				

c: measured channel, k: order for analysis

Total harmonic current distortion factor THDIF (%)

Single-phase 2-wire 1P2W	Single-phase 3-wire 1P3W	Three-phase 3-wire 3P3W2M	Three-phase 3-wire 3P3W3M	Three-phase 4-wire 3P4W
$THDIF1$ $THDIF4$ $THDIF_c = \frac{\sqrt{\sum_{k=2}^K (I_{ck})^2}}{I_{c1}} \times 100$	$THDIF1$ $THDIF2$ $THDIF4$	$THDIF1$ $THDIF2$ $THDIF4$	$THDIF1$ $THDIF2$ $THDIF3$ $THDIF4$	$THDIF1$ $THDIF2$ $THDIF3$ $THDIF4$
<ul style="list-style-type: none"> • Calculate the Discrete Fourier Transform of harmonic RMS current at 2048 points (about once every 10 cycles at 50 Hz or every 12 cycles at 60 Hz). • In the equation above, K indicates the total of orders analyzed. • Select either THDIF or THDIR to calculate the total harmonic current distortion factor. 				

c: measured channel, k: order for analysis

Total harmonic voltage distortion factor THDUR (%)

Single-phase 2-wire 1P2W	Single-phase 3-wire 1P3W	Three-phase 3-wire 3P3W2M	Three-phase 3-wire 3P3W3M	Three-phase 4-wire 3P4W
$THDUR1$ $THDUR4$ $THDUR_c = \frac{\sqrt{\sum_{k=2}^K (U_{ck})^2}}{\sqrt{\sum_{k=1}^K (U_{ck})^2}} \times 100$	$THDUR1$ $THDUR2$ $THDUR4$	$THDUR12$ $THDUR32$ $THDUR4$	$THDUR12$ $THDUR23$ $THDUR31$ $THDUR4$	$THDUR1$ $THDUR2$ $THDUR3$ $THDUR4$
<ul style="list-style-type: none"> • Calculate the Discrete Fourier Transform of harmonic RMS voltage at 2048 points (about once every 10 cycles at 50 Hz or every 12 cycles at 60 Hz). • Three-phase 3-wire indicates the result of harmonic calculation with line-to-line voltage. • In the equation above, K indicates the total of orders analyzed. • Select either THDUF or THDUR to calculate the total harmonic voltage distortion factor. 				

c: measured channel, k: order for analysis

Total harmonic current distortion factor THDIR (%)

Single-phase 2-wire 1P2W	Single-phase 3-wire 1P3W	Three-phase 3-wire 3P3W2M	Three-phase 3-wire 3P3W3M	Three-phase 4-wire 3P4W
$THDIR1$ $THDIR4$ $THDIRc = \frac{\sqrt{\sum_{k=2}^K (I_{ck})^2}}{\sqrt{\sum_{k=1}^K (I_{ck})^2}} \times 100$	$THDIR1$ $THDIR2$ $THDIR4$	$THDIR1$ $THDIR2$ $THDIR4$	$THDIR1$ $THDIR2$ $THDIR3$ $THDIR4$	$THDIR1$ $THDIR2$ $THDIR3$ $THDIR4$

- Calculate the Discrete Fourier Transform of harmonic RMS current at 2048 points (about once every 10 cycles at 50 Hz or every 12 cycles at 60 Hz).
- In the equation above, K indicates the total of orders analyzed.
- Select either THDIF or THDIR to calculate the total harmonic current distortion factor.

c: measured channel, k: order for analysis

Harmonic voltage phase angle θ_{Uk} (deg)

Single-phase 2-wire 1P2W	Single-phase 3-wire 1P3W	Three-phase 3-wire 3P3W2M	Three-phase 3-wire 3P3W3M	Three-phase 4-wire 3P4W
θ_{U1k} θ_{U4k} $\theta_{Uck} = \tan^{-1} \left\{ \frac{U_{ckr}}{-U_{cki}} \right\}$	θ_{U1k} θ_{U2k} θ_{U4k}	θ_{U12k} θ_{U32k} θ_{U4k}	θ_{U12k} θ_{U23k} θ_{U31k} θ_{U4k}	θ_{U1k} θ_{U2k} θ_{U3k} θ_{U4k}

- Calculate the Discrete Fourier Transform of harmonic RMS voltage at 2048 points (about once every 10 cycles at 50 Hz or every 12 cycles at 60 Hz).
- Three-phase 3-wire indicates the result of harmonic calculation with line-to-line voltage.
- Corrects the PLL source fundamental wave to 0° and displays the harmonic voltage phase angle.
- When $U_{ckr} = U_{cki} = 0$ $\theta_{Uk} = 0^\circ$.
- The harmonic voltage used in calculations is only taken from integral harmonics.

c: measured channel, k: order for analysis, r: resistance after FFT, i: reactance after FFT

Harmonic current phase angle θ_{Ik} (deg)

Single-phase 2-wire 1P2W	Single-phase 3-wire 1P3W	Three-phase 3-wire 3P3W2M	Three-phase 3-wire 3P3W3M	Three-phase 4-wire 3P4W
θ_{I1k} θ_{I4k} $\theta_{Ick} = \tan^{-1} \left\{ \frac{I_{ckr}}{-I_{cki}} \right\}$	θ_{I1k} θ_{I2k} θ_{I4k}	θ_{I1k} θ_{I2k} θ_{I4k}	θ_{I1k} θ_{I2k} θ_{I3k} θ_{I4k}	θ_{I1k} θ_{I2k} θ_{I3k} θ_{I4k}

- Calculate the Discrete Fourier Transform of harmonic RMS current at 2048 points (about once every 10 cycles at 50 Hz or every 12 cycles at 60 Hz).
- Corrects the PLL source fundamental wave to 0° and displays the harmonic current phase angle.
- When $I_{ckr} = I_{cki} = 0$ $\theta_{Ik} = 0^\circ$.
- The harmonic current used in calculations is only taken from integral harmonics.

c: measured channel, k: order for analysis, r: resistance after FFT, i: reactance after FFT

Harmonic voltage-current phase difference θ_k (deg)

Single-phase 2-wire 1P2W	Single-phase 3-wire 1P3W	Three-phase 3-wire 3P3W2M	Three-phase 3-wire 3P3W3M	Three-phase 4-wire 3P4W
θ_{1k} $\theta_{ck} = \theta_{c1k} - \theta_{cUk}$	θ_{1k} θ_{2k}	θ_{1k} θ_{2k}	θ_{1k} θ_{2k} θ_{3k}	θ_{1k} θ_{2k} θ_{3k}
—————	$\theta_{sum} = \tan^{-1} \left\{ \frac{Q_{sumk}}{P_{sumk}} \right\}$	$\theta_{sum} = \tan^{-1} \left\{ \frac{Q_{sumk}}{P_{sumk}} \right\}$	$\theta_{sum} = \tan^{-1} \left\{ \frac{Q_{sumk}}{P_{sumk}} \right\}$	$\theta_{sum} = \tan^{-1} \left\{ \frac{Q_{sumk}}{P_{sumk}} \right\}$
<ul style="list-style-type: none"> • Calculate harmonic power at 2048 points for voltage and current (about once every 10 cycles at 50 Hz or every 12 cycles at 60 Hz). • When $P_{sumk} = Q_{sumk} = 0$, $\theta_k = 0^\circ$. • P_{sumk} indicates the total harmonic power. (See the harmonic power formula.) • Q_{sumk} indicates the total harmonic reactive power. (See the harmonic reactive power formula.) 				

c: measured channel, k: order for analysis, r: resistance after FFT, i: reactance after FFT

Voltage fluctuation ΔU (Vrms)

Single-phase 2-wire 1P2W	Single-phase 3-wire 1P3W	Three-phase 3-wire 3P3W2M	Three-phase 3-wire 3P3W3M	Three-phase 4-wire 3P4W
$\Delta U_{(c)} = U_c - U_r$	$\Delta U_{(1)}$ $\Delta U_{(2)}$	$\Delta U_{(12)}$ $\Delta U_{(32)}$	$\Delta U_{(12)}$ $\Delta U_{(23)}$ $\Delta U_{(31)}$	$\Delta U_{(1)}$ $\Delta U_{(2)}$ $\Delta U_{(3)}$
<p>“U_r” is the same value as the nominal voltage for standard voltage with respect to voltage fluctuations.</p>				

c: measured channel, r: resistance after FFT

Voltage flicker ΔV_{10} (V)

Single-phase 2-wire 1P2W	Single-phase 3-wire 1P3W	Three-phase 3-wire 3P3W2M	Three-phase 3-wire 3P3W3M	Three-phase 4-wire 3P4W
$\Delta V_{10(1)}$	$\Delta V_{10(1)}$ $\Delta V_{10(2)}$	$\Delta V_{10(12)}$ $\Delta V_{10(32)}$	$\Delta V_{10(12)}$ $\Delta V_{10(23)}$ $\Delta V_{10(31)}$	$\Delta V_{10(1)}$ $\Delta V_{10(2)}$ $\Delta V_{10(3)}$
$\Delta V_{10(c)} = \frac{100}{U_f} \sqrt{\sum (a_n \times \Delta U_n)^2}$				
<ul style="list-style-type: none"> • U_r is the basic voltage for the change in voltage and U_f is the basic voltage for the voltage flicker, and they both operate automatically. • U_r indicates the value passing through the primary LPF (for a response time of 1 m) and U_f indicates the average RMS voltage over a 1-minute interval. • a_n is the flicker luminosity coefficient corresponding to the change in frequency f_n (Hz) that can be detected from the flicker luminosity curve. • ΔU_n is the change in voltage for f_n. • For connections other than single-phase two-wire, you can select any ΔV_{10} value for calculation. 				

c: measured channel

ΔV_{10} Perceived flicker curve

ΔV_{10} Perceived flicker coefficient

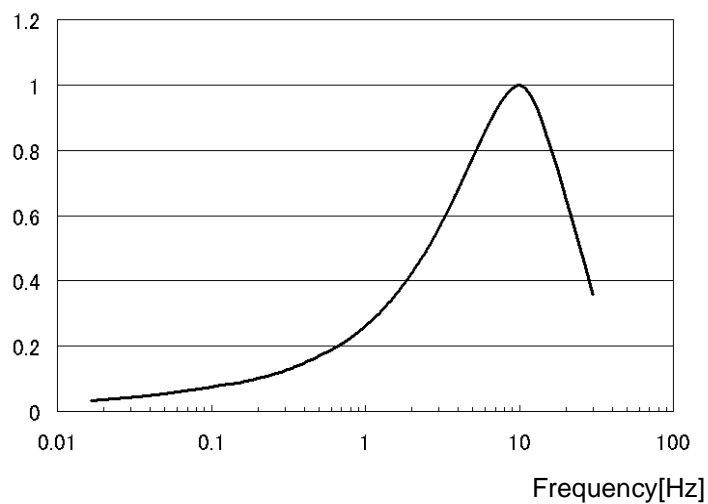

Short interval voltage flicker Pst

Single-phase 2-wire 1P2W	Single-phase 3-wire 1P3W	Three-phase 3-wire 3P3W2M	Three-phase 3-wire 3P3W3M	Three-phase 4-wire 3P4W
$Pst1$	$Pst1$	$Pst1$	$Pst1$	$Pst1$
$Pstc = \sqrt{K_1 P_{0.1} + K_2 P_{1s} + K_3 P_{3s} + K_4 P_{10s} + K_5 P_{50s}}$	$Pst2$	$Pst2$	$Pst2$ $Pst3$	$Pst2$ $Pst3$
<ul style="list-style-type: none"> Indicates the following values: $K_1=0.0314$, $K_2=0.0525$, $K_3=0.0657$, $K_4=0.28$, $K_5=0.08$. The cumulative probability function (CPF) is in the 1024 class. Searches using linear interpolation between the various cumulative probabilities (P_i) and calculates a smoothed cumulative probability using the following methods (P_{is}). $P_{1s} = (P_{0.7} + P_1 + P_{1.5})/3$ $P_{3s} = (P_{2.2} + P_3 + P_4)/3$ $P_{10s} = (P_6 + P_8 + P_{10} + P_{13} + P_{17})/5$ $P_{50s} = (P_{30} + P_{50} + P_{80})/3$ 				

c: measured channel

Long interval voltage flicker Plt

Single-phase 2-wire 1P2W	Single-phase 3-wire 1P3W	Three-phase 3-wire 3P3W2M	Three-phase 3-wire 3P3W3M	Three-phase 4-wire 3P4W
$Plt1$	$Plt1$	$Plt1$	$Plt1$	$Plt1$
$Pltc = \sqrt[3]{\frac{\sum_{n=1}^N (P_{stm})^3}{N}}$	$Plt2$	$Plt2$	$Plt2$ $Plt3$	$Plt2$ $Plt3$
<ul style="list-style-type: none"> N indicates the number of measurements (N = 12 measurements). (When $N < 12$, the number of measurements N is used.) 				

c: measured channel

Appendix

Measurement Range and Nominal Voltage

The voltage and current ranges of this unit are as follows.
This unit is not equipped with an automatic range selection function, therefore you must select the operation ranges.

Voltage range	CH 1 to 3	150 V, 300 V, 600 V
	CH 4 (AC)	60 V, 150 V, 300 V, 600 V
	CH 4 (DC)	60 V, 600 V
Current range	0.1 mV/A	500 A, 5000 A
	1 mV/A (9661)	50 A, 500 A
	1 mV/A (9660)	50 A, 100 A
	10 mV/A (9694)	5 A, 50 A
	100 mV/A	0.5 A, 5 A
	5000 A 9667	500A, 5000A
	500 A 9667	50A, 500A
	1000 A 9669	100A, 1000A

The display and effective measurement ranges (ranges where accuracy is certain) of measurement ranges are as follows.

Voltage range

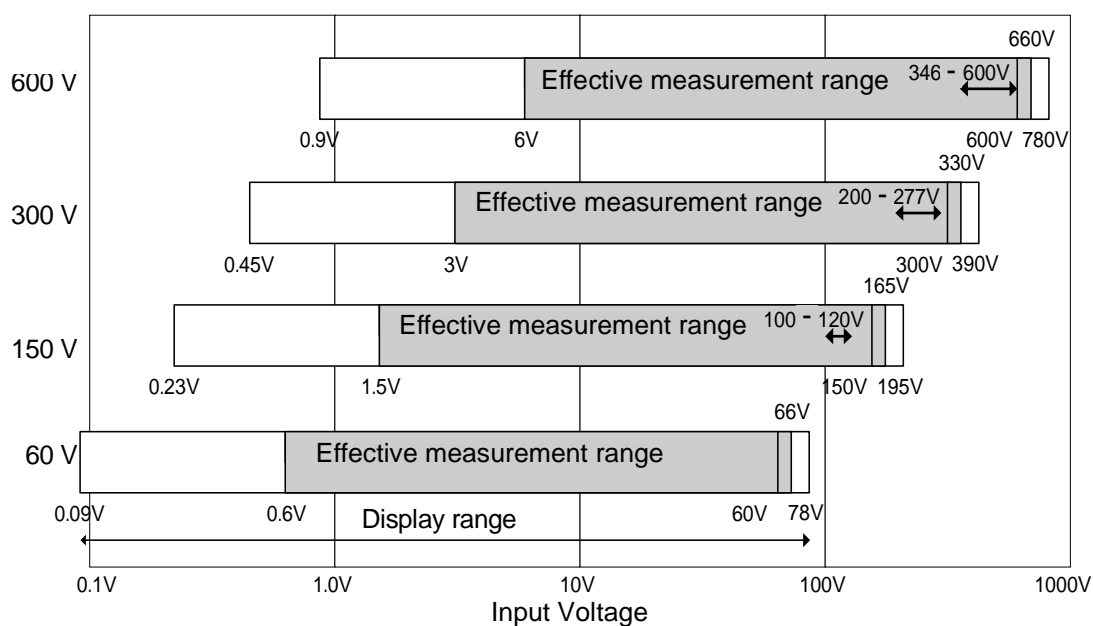

Set the nominal voltage so that it does not exceed the selected voltage range.
You can use a nominal voltage of 346 to 600 V in a 600 V voltage range.
You can use a nominal voltage of 200 to 277 V in a 300 V voltage range.
You can use a nominal voltage of 100 to 120 V in a 150 V voltage range.

Current range

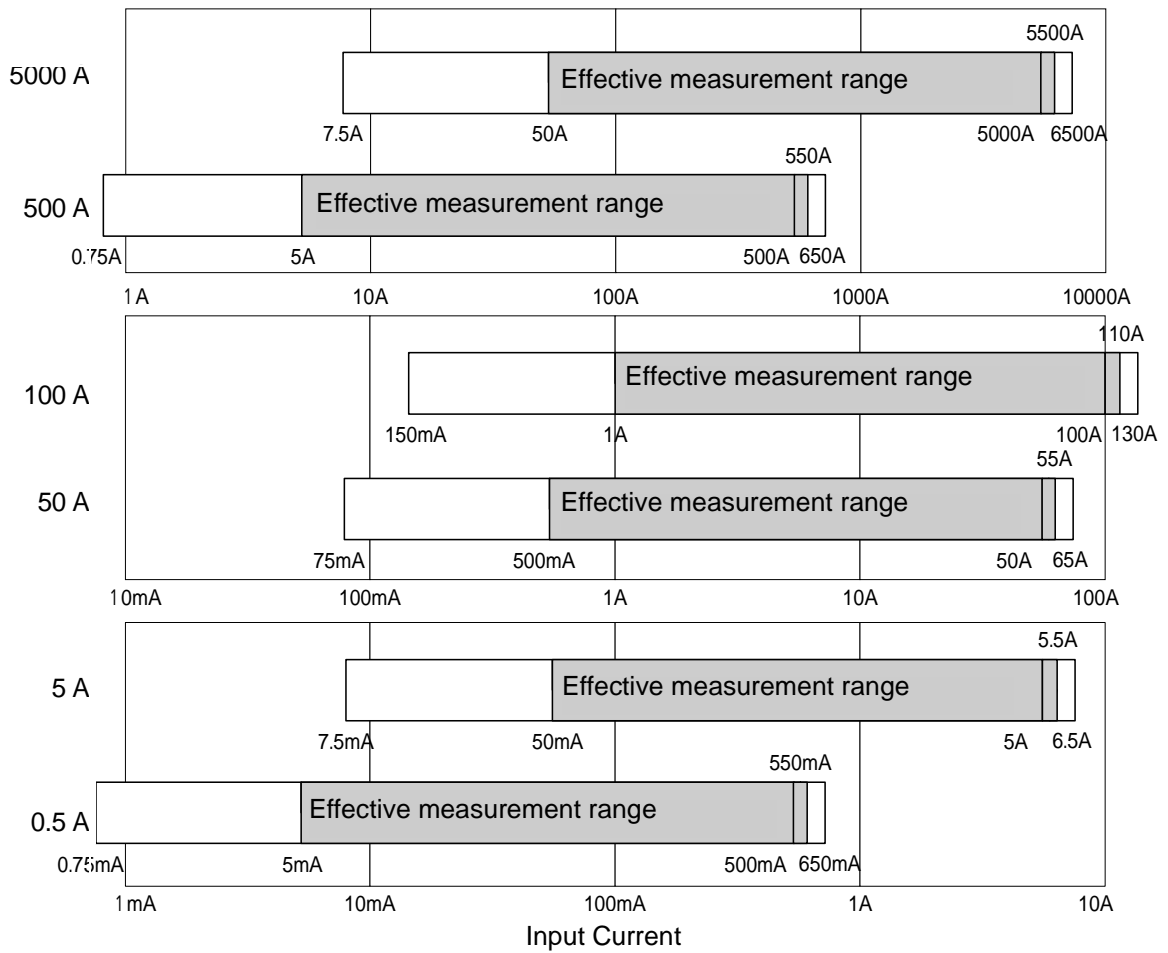

TIME PLOT Recording Method

TIME PLOT screen ---- RMS, HARMONICS

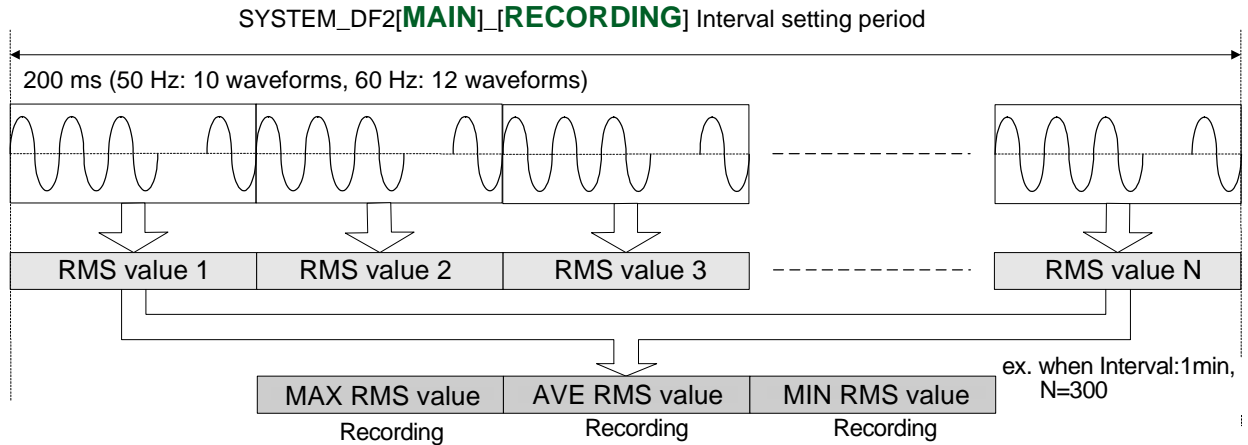

MAX and MIN values only for harmonics and inter-harmonics

TIME PLOT screen ---- VOLTAGE

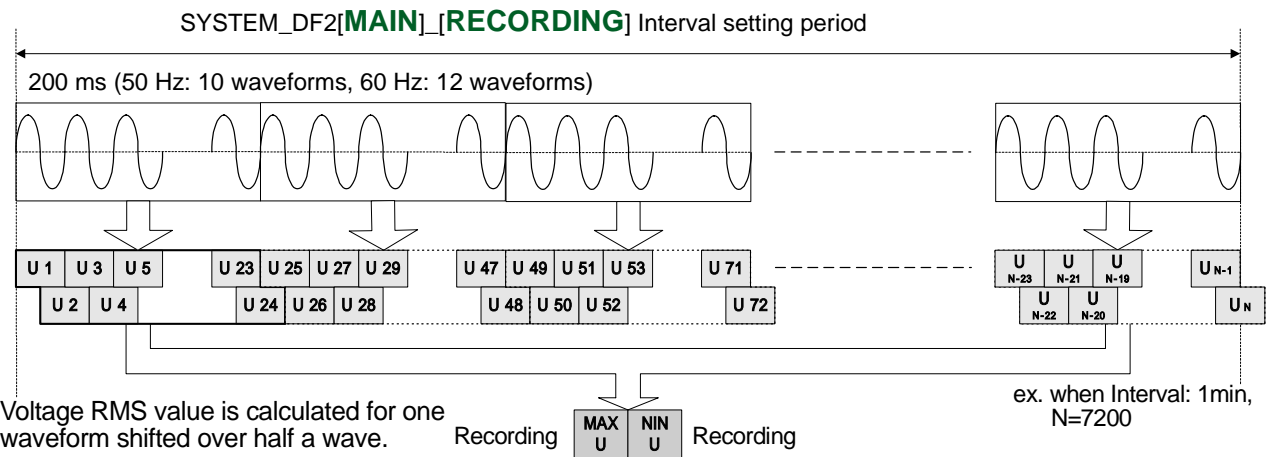

Voltage RMS value is calculated for one waveform shifted over half a wave.

(Example)
24 calculated values U exist within 200 ms at 60 Hz: 12 cycles.

Event Waveform Recording Method

TIME PLOT screen ---- **RMS, HARMONICS** (Event setting -power and harmonics)

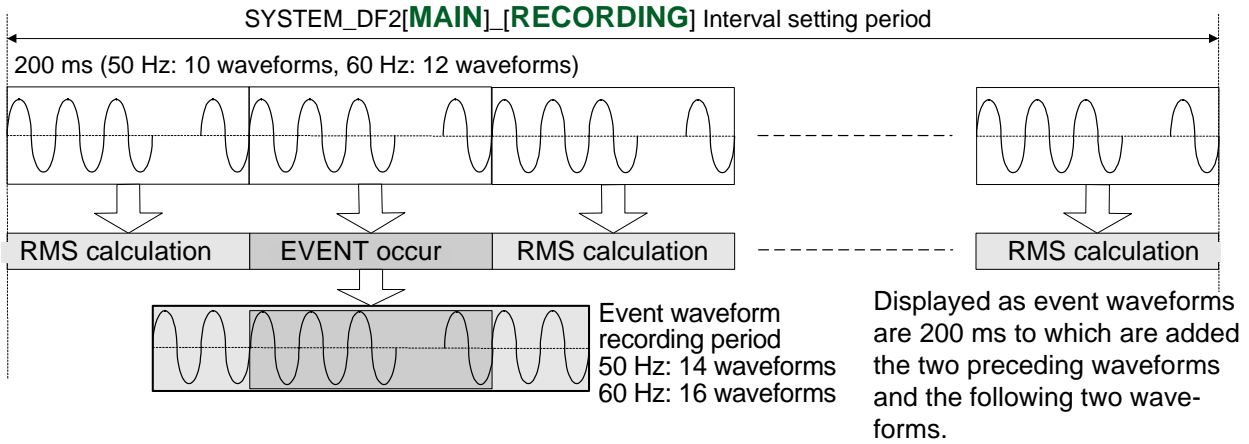

TIME PLOT screen ---- **VOLTAGE** (Event setting-voltage)

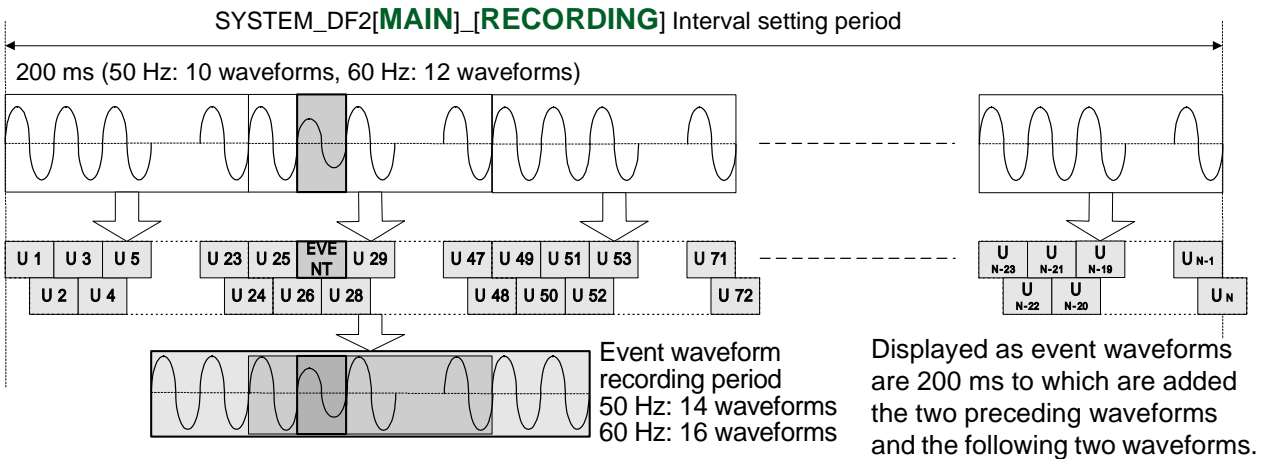

Detecting Anomalies and Phenomena Due to Drops in Power Quality

Troubles due to drops in power quality:

Interruptions in the reception transformer and malfunctions in the terminal control device

- The light flickers.
- Light bulbs burn out more quickly.
- The OA device malfunctions.
- Sometimes the device does not work correctly.
- The reactor's condenser overheats.
- Sometimes the electrical overload, reverse phase, or missing phase relays malfunction.



Detecting phenomena

Power quality	Waveform display	Phenomenon	Malfunction
Transient overvoltage (impulse)		Occurs due to phenomena such as lightning, breaker point damage, or closure on the circuit breaker or relay. Often occurs when there is a radical change in voltage or when the peak voltage is high.	Close to the source of the break, the device's power is damaged because of exceptionally high voltages and this may cause the device to reset.
Voltage dip (SAG)		A momentary voltage drop occurs caused by large rush currents in the load, such as starting-up a motor.	A drop in voltage may cause the device to stop operating or reset.
Voltage swell (SURGE)		Occurs when power lines subject to lightning strikes or heavy loads are opened and closed, causing the voltage to surge momentarily.	A surge in voltage may cause the device's power to be damaged or the device to reset.
Flicker		Blast furnaces, arc welders, and thyristor control loads cause flicker, and voltage impulses occur regularly during single and multiple cycles.	Because this phenomenon reoccurs regularly, it may cause the light to flicker or the device to malfunction.
Interruption		Circuit breaker trips occur, mainly caused by accidents at power companies (such as stops in power transmission because of lightning strikes) or short circuits, and the power supply stops momentarily or for an indefinite time.	Recently, due to the spread of UPS (uninterruptible power sources), most of these problems can be fixed using a computer, but this may cause the device to stop operating due to an interruption or to reset.
Harmonics		Many device power sources now use semiconductor control devices and harmonics occur because of distorted voltage or current waveforms.	When harmonic components become too large, they can cause serious accidents, such as overheating the motor transformer or burning out the reactor connected to the phase advance capacitor.
Unbalance factor		When the load of the specified phase becomes too heavy due to fluctuations in loads connected to each power line phases, or when operating an uneven device, the voltage and current waveforms become distorted, causing voltage drops	Voltage imbalance, reverse phase-to-neutral voltage, and harmonics may cause accidents such as uneven motor rotation, 3E breaker trips, and overload heating in the transformer.

Terminology

LAN

LAN is the abbreviation of Local Area Network. The LAN was developed as a network for transferring data through a PC within a local area, such as an office, factory, or school.

This device comes equipped with the LAN adapter Ethernet 10Base-T. 10Base-T is appointed by IEEE802 and has a data transfer speed of 10 Mbps. Use a twisted-pair cable to connect this device to the hub (central computer) of your LAN. The maximum length of the cable connecting the terminal and the hub is 100 m. Similar to the RS-232C interface protocol, the LAN interface protocol supports communications using TCP/IP.

RS-232C

The RS-232C is a serial interface established by the EIA (Electronics Industries Association), and conforms to the specifications for DTE (data terminal equipment) and DCE (data circuit terminating equipment) interface conditions.

Using the signal line part of the RS-232C specifications with this unit allows you to use an external printer, PC, or modem.

When using a PC or modem, the RS-232C interface supports communications using TCP/IP as the RS-232C protocol. TCP/IP is widely used as a LAN protocol and is the basic protocol used on the Internet. These specifications are available to the public on the Internet in a document called RFC. (<ftp://ds.internic.net/rfc>)

PLL

PLL is the abbreviation of Phase Locked Loop and is a phase synchronization circuit.

This unit is synchronized with the fundamental cycle (at 50 or 60 Hz) and samples voltage and current input waveforms at a frequency of 256 samples per cycle. This is an effective input waveform sampling method, used in analyzing harmonics by FFT when sampling at a frequency of 256 samples per cycle.

Conventional measurement instruments could not sample the entire input waveform unless it was input with PLL (PLL source), therefore they could not calculate the input waveform. This condition is called PLL unlock.

However, when no PLL source is found during measurement with this device, it momentarily switches to the internal clock. The internal clock is synchronized with a frequency of 256 samples per cycle, the same as the frequency prior to the occurrence of PLL unlock. Using this function, sampling is not possible when interruptions occur, but you can search the waveform for interruptions.

However, it is still possible to calculate harmonics correctly without a PLL source input because during harmonics analysis a rectangular window open on the waveform for FFT (10 cycles at 50 Hz or 12 cycles at 60 Hz).

As a warning, PLL synchronization on the SYSTEM settings display area of the screen or the frequency source area light red.

Out of crest factor

The crest factor expresses the size of the dynamic range of input on the measurement device and can be defined with the following expression.

Crest factor = crest value (peak value)/RMS value

For example, when measuring a distorted wave with a small RMS and a large peak on a measurement device with a small crest factor, because the peak of the distorted wave exceeds the detection range of the input circuit, an RMS or harmonic measurement error occurs.

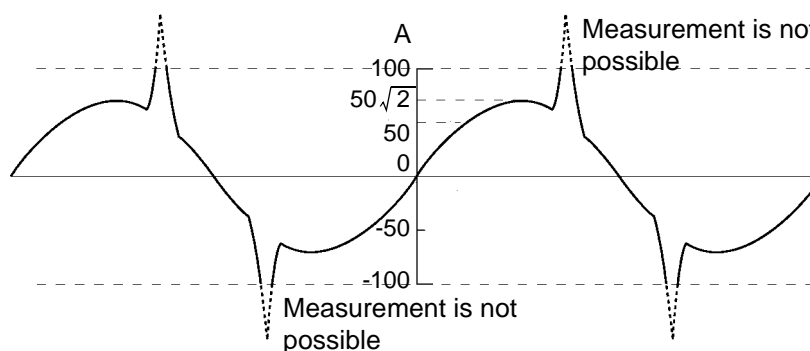

A measurement device with a small crest factor
(When the crest factor is 2 for a 50 A range)

When you increase the measurement range, the peak does not exceed the input circuit's detection range, but because the resolution of the RMS decreases, measurement errors may occur.

With this device, because the voltage input area has a crest factor of 3 and the current input area has a crest factor of 4, the peak can be obtained even for large distorted waves.

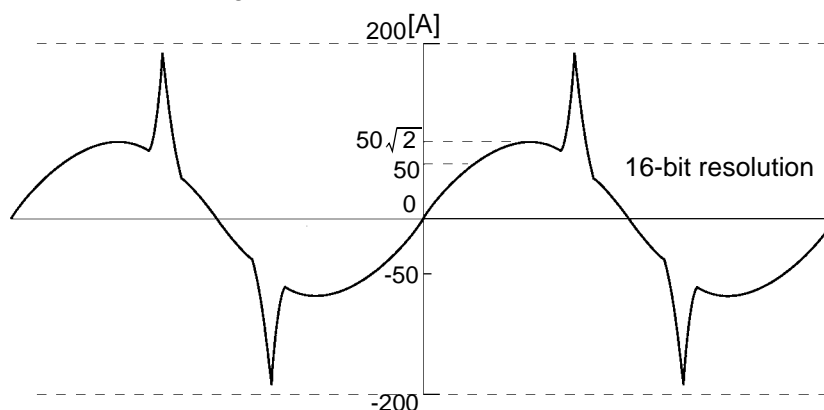

Crest factors of the 3196

(The crest factor of the current input area is 4.)

However, when a measurement that exceeds the peak is input, it appears outside the crest factor and you are informed of data that contains measurement errors.

Harmonics phase angle and harmonic phase difference

The harmonic voltage phase angle and harmonic current phase angle are the standard for the PLL source phase (for input based on PLL when U1, U2, or U3 is selected on this device) fundamental wave component.

The differences in phase of each harmonic order component and the phase of the fundamental wave component is expressed as an angle (°) and - indicates a LAG, whereas + indicates a LEAD.

The harmonic voltage-current phase difference expresses the difference between the phase of each harmonic voltage component and the phase of each harmonic current component of each channel as an angle (°).

The sum is the total power factor of each harmonic order (calculated from the total harmonic power and the total harmonic reactive power) expressed as an angle (°). When the harmonic voltage-current phase difference is between -90° and +90°, the harmonic order is flowing in the direction of the load. When it is between +90° and +180° or -90° and -180°, the harmonic order is flowing away from the load.

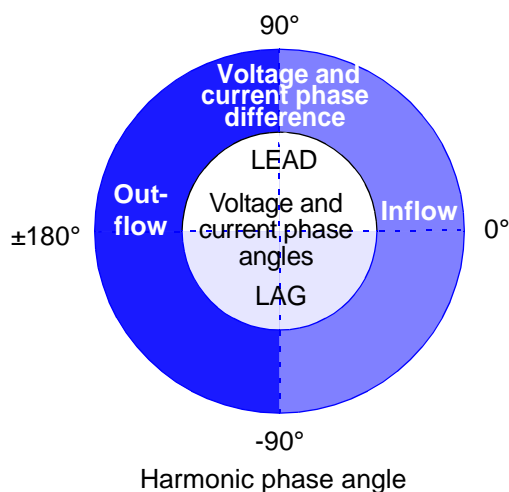

K Factor

Shows the power loss caused by the harmonic current in transformers. Also referred to as the “multiplication factor.” The K factor (KF) is formulated as shown below:

$$KF = \frac{\sum_{k=2}^{50} (k^2 \times I_k^2)}{\sum_{k=2}^{50} I_k^2}$$

k: Order of harmonics
Ik: Ratio of the harmonic current to the fundamental wave current [%]

Higher-order harmonic currents have a greater influence on the K factor than lower-order harmonic currents.

Purpose of measurement

To measure the K factor in a transformer when subjected to maximum load. If the measured K factor is larger than the multiplication factor of the transformer used, the transformer must be replaced with one with a larger K factor, or the load on the transformer must be reduced. The replacement transformer should have a K factor one rank higher than the measured K factor for the transformer being replaced.

Unbalance factor

If the phases of the three-phase alternating voltage (current) each have the same voltage and deviate from each other by 120 degrees, the voltage (current) is referred to as “balanced (symmetrical) three-phase voltage (current).” If the voltages (currents) of the three phases differ or if the difference between each of the phases is not 120 degrees, the voltage (current) is referred to as “unbalanced (asymmetrical) three-phase voltage (current).” Though all of the following descriptions refer to voltage, they apply to current as well.

Degree of unbalance in three-phase alternating voltage

Normally described as the voltage unbalance factor, which is the ratio of negative-phase voltage to positive-phase voltage

$$\text{Voltage unbalance factor} = \frac{\text{Negative-phase voltage}}{\text{Positive-phase voltage}} \times 100 \text{ [\%]}$$

Zero-phase/positive-phase/negative-phase voltage

The concept of a zero-phase-sequence/positive-phase-sequence/negative-phase-sequence component in a three-phase alternating circuit applies the method of symmetrical coordinates (a method in which a circuit is treated so as to be divided into symmetrical components of a zero phase, positive phase, and negative phase).

- **Zero-phase-sequence component:** Voltage that is equal in each phase. Described as V_0 . (Subscript 0: Zero-phase-sequence component)
- **Positive-phase-sequence component:** Symmetrical three-phase voltage in which the value for each phase is equal, and each of the phases is delayed by 120 degrees in the phase sequence a->b->c. Described as V_1 . (Subscript 1: Positive-phase-sequence component)
- **Negative-phase-sequence component:** Symmetrical three-phase voltage in which the value for each phase is equal, and each of the phases is delayed by 120 degrees in the phase sequence a->c->b. Described as V_2 . (Subscript 2: Negative-phase-sequence component)

If V_a , V_b , and V_c are given as the three-phase alternating voltage, the zero-phase voltage, positive-phase voltage, and negative voltage are formulated as shown below.

$$\text{Zero-phase voltage } V_0 = \frac{V_a + V_b + V_c}{3}$$

$$\text{Positive-phase voltage } V_1 = \frac{V_a + aV_b + a^2V_c}{3}$$

$$\text{Negative-phase voltage } V_2 = \frac{V_a + a^2V_b + aV_c}{3}$$

a is referred to as the “vector operator.” It is a vector with a magnitude of 1 and a phase angle of 120 degrees. Therefore, the phase angle is advanced by 120 degrees if multiplied by a , and by 240 degrees if multiplied by a^2 . If the three-phase alternating voltage is balanced, the zero-phase voltage and negative-phase voltage are 0, and only positive-phase voltage, which is equal to the effective value of the three-phase alternating voltage, is described.

Unbalance factor of three-phase current

The current unbalance factor is several times larger than the voltage unbalance factor. The less a three-phase induction motor slips, the greater the difference between these two factors. Voltage unbalance causes such phenomena as current unbalance, an increase in temperature, an increase in input, a decline in efficiency, and an increase in vibration and noise.

Displacement power factor (DPF)

The power factor (PF) is the ratio of active power to apparent power. An inductive load delays the current behind the voltage, and a capacitive load advances the current ahead of the voltage.

PF (power factor)	$0 < PF < 1$	There is reactive power, which is the power supplied but not consumed.
	$PF = 1$	All the supplied power is consumed, and there is no reactive power.
	$PF = -1$	The power, voltage, and current are generated in phase.
	$-1 < PF < 0$	Phase lead or phase delay of the power and current is generated.

In general, a power factor is calculated using all effective values, and harmonic contents are therefore included. In addition to this power factor (PF), the displacement power factor (DPF) is the ratio of active power to apparent power. However, the displacement power factor (DPF) is described using the cosine of the phase difference between the fundamental wave current and the fundamental wave voltage and does not include the harmonic contents of voltage or current.

DPF (displacement power factor)

DPF (displacement power factor)	$0 < DPF < 1$	The current phase is ahead of or behind the voltage phase. Equipment consumes power.
	$DPF = 1$	The current and voltage are in phase. Equipment consumes power.
	$DPF = -1$	The current and voltage are in opposite phases. Equipment produces power.
	$-1 < DPF < 0$	The current phase is ahead of or behind the voltage phase. Equipment produces power.

The displacement power factor is the same as the power factor in watt-hour meters used in ordinary homes, and also the same as the power factor calculated using the true reactive-power-meter method used in 3196. If the displacement power factor is low (the current is behind the voltage), add a phase-advancing capacitor to the electric system for correction. In general, a displacement power factor is used in an electrical system, and a power factor is used in equipment. In one neighborhood, the power factor shows a larger value than the displacement power factor.

Text Time-sequence Data-header Composition

Remark: Each item is separated by a comma (,).

Classification	Header	Explanation	
Date and Time	Date	Date	2001/8/20
	Time	Time	8:12:00
Voltage fluctuation*	Umax1,...,Umax3	Max. value of voltage fluctuation	CH1 - CH3
	Umin1,...,Umin3	Min. value of voltage fluctuation	CH1 - CH3
RMS value fluctuation Maximum value	MaxFreq	Frequency	
	MaxUrms1,...,MaxUrms4	RMS voltage value	CH1 - CH4
	MaxU+peak1,...,MaxU+peak4	Voltage waveform peak (+)	CH1 - CH4
	MaxU-peak1,...,MaxU-peak4	Voltage waveform peak (-)	CH1 - CH4
	MaxIrms1,...,MaxIrms4	RMS current value	CH1 - CH4
	MaxI+peak1,...,MaxI+peak4	Current waveform peak (+)	CH1 - CH4
	MaxI-peak1,...,MaxI-peak4	Current waveform peak (-)	CH1 - CH4
	MaxUave	Average RMS voltage value	ave
	MaxIave	Average RMS current value	ave
	MaxP1,...,MaxP3	Active power	CH1 - CH3
	MaxPsum	Sum of active power	sum
	MaxS1,...,MaxS3	Apparent power	CH1 - CH3
	MaxSsum	Sum of apparent power	sum
	MaxQ1,...,MaxQ3	Reactive power	CH1 - CH3
	MaxQsum	Sum of reactive power	sum
	MaxPF1,...,MaxPF3	Power factor/Displacement power factor	CH1 - CH3
	MaxPFsum	Sum of Power factor/Displacement power factor	sum
	MaxKF1,...,MaxKF4	K factor	CH1 - CH4
	MaxUunb	Voltage unbalance factor	
	MaxIunb	Current unbalance factor	
	MaxUthd1,...,MaxUthd4	Total harmonic voltage distortion factor	CH1 - CH4
	MaxIthd1,...,MaxIthd4	Total harmonic current distortion factor	CH1 - CH4
	MaxU1(1),...,MaxU4(50)	Harmonic voltage	CH1 - CH4 1st - 50th
	MaxI1(1),...,MaxI4(50)	Harmonic current	CH1 - CH4 1st - 50th
	MaxP1(1),...,MaxP3(50)	Harmonic power	CH1 - CH3 1st - 50th
	MaxPhase1(1),...,MaxPhase3(50)	Harmonic voltage-current phase difference	CH1 - CH3 1st - 50th
	MaxPsum(1),...,MaxPsum(50)	Harmonic power	sum 1st - 50th
	MaxPhasesum(1),...,MaxPhasesum(50)	Harmonic voltage-current phase difference	sum 1st - 50th
	MaxUtihd1,...,MaxUtihd4	Total harmonic voltage distortion factor	CH1 - CH4
	MaxItihd1,...,MaxItihd4	Total harmonic current distortion factor	CH1 - CH4
MaxU1(0.5),...,MaxU4(49.5)	Inter-harmonic voltage	CH1 - CH4 0.5 - 49.5th	
MaxI1(0.5),...,MaxI4(49.5)	Inter-harmonic current	CH1 - CH4 0.5 - 49.5th	

*: When Δ U is selected as the voltage recording setting, Umax1,Umax3 becomes dUmax1,dUmax3, and Umin1,Umin3 becomes dUmin1,dUmin3.

Classification	Header	Explanation
RMS value fluctuation Minimum value	MinFreq	Frequency
	MinUrms1,...,MinUrms4	RMS voltage value CH1 - CH4
	MinU+peak1,...,MinU+peak4	Voltage waveform peak (+) CH1 - CH4
	MinU-peak1,...,MinU-peak4	Voltage waveform peak (-) CH1 - CH4
	MinIrms1,...,MinIrms4	RMS current value CH1 - CH4
	MinI+peak1,...,MinI+peak4	Current waveform peak (+) CH1 - CH4
	MinI-peak1,...,MinI-peak4	Current waveform peak (-) CH1 - CH4
	MinUave	Average RMS voltage value ave
	MinIave	Average RMS current value ave
	MinP1,...,MinP3	Active power CH1 - CH3
	MinPsum	Sum of active power sum
	MinS1,...,MinS3	Apparent power CH1 - CH3
	MinSsum	Sum of apparent power sum
	MinQ1,...,MinQ3	Reactive power CH1 - CH3
	MinQsum	Sum of reactive power sum
	MinPF1,...,MinPF3	Power factor/Displacement power factor CH1 - CH3
	MinPFsum	Sum of Power factor/Displacement power factor sum
	MinKF1,...,MinKF4	K factor CH1 - CH4
	MinUunb	Voltage unbalance factor
	MinIunb	Current unbalance factor
	MinUthd1,...,MinUthd4	Total harmonic voltage distortion factor CH1 - CH4
	MinIthd1,...,MinIthd4	Total harmonic current distortion factor CH1 - CH4
	MinU1(1),...,MinU4(50)	Harmonic voltage CH1 - CH4 1st - 50th
	MinI1(1),...,MinI4(50)	Harmonic current CH1 - CH4 1st - 50th
	MinP1(1),...,MinP3(50)	Harmonic power CH1 - CH3 1st - 50th
	MinPhase1(1),...,MinPhase3(50)	Harmonic voltage-current phase difference CH1 - CH3 1st - 50th
	MinPsum(1),...,MinPsum(50)	Harmonic power sum 1st - 50th
	MinPhasesum(1),...,MinPhasesum(50)	Harmonic voltage-current phase difference sum 1st - 50th
	MinUtihd1,...,MinUtihd4	Total harmonic voltage distortion factor CH1 - CH4
	MinItihd1,...,MinItihd4	Total harmonic current distortion factor CH1 - CH4
	MinU1(0.5),...,MinU4(49.5)	Inter-harmonic voltage CH1 - CH4 0.5 - 49.5th
	MinI1(0.5),...,MinI4(49.5)	Inter-harmonic current CH1 - CH4 0.5 - 49.5th

Classification	Header	Explanation
RMS value fluctuation Average value	AveFreq	Frequency
	AveUrms1,...,AveUrms4	RMS voltage value CH1 - CH4
	AveU+peak1,...,AveU+peak4	Voltage waveform peak (+) CH1 - CH4
	AveU-peak1,...,AveU-peak4	Voltage waveform peak (-) CH1 - CH4
	AveIrms1,...,AveIrms4	RMS current value CH1 - CH4
	AveI+peak1,...,AveI+peak4	Current waveform peak (+) CH1 - CH4
	AveI-peak1,...,AveI-peak4	Current waveform peak (-) CH1 - CH4
	AveUave	Average RMS voltage value ave
	AveIave	Average RMS current value ave
	AveP1,...,AveP3	Active power CH1 - CH3
	AvePsum	Sum of active power sum
	AveS1,...,AveS3	Apparent power CH1 - CH3
	AveSsum	Sum of apparent power sum
	AveQ1,...,AveQ3	Reactive power CH1 - CH3
	AveQsum	Sum of reactive power sum
	AvePF1,...,AvePF3	Power factor/Displacement power factor CH1 - CH3
	AvePFsum	Sum of Power factor/Displacement power factor sum
	AveKF1,...,AveKF4	K factor CH1 - CH4
	AveUunb	Voltage unbalance factor
	AveIunb	Current unbalance factor
	AveUthd1,...,AveUthd4	Total harmonic voltage distortion factor CH1 - CH4
	AveIthd1,...,AveIthd4	Total harmonic current distortion factor CH1 - CH4
	AveU1(1),...,AveU4(50)	Harmonic voltage CH1 - CH4 1st - 50th
	AveI1(1),...,AveI4(50)	Harmonic current CH1 - CH4 1st - 50th
	AveP1(1),...,AveP3(50)	Harmonic power CH1 - CH3 1st - 50th
	AvePhase1(1),...,AvePhase3(50)	Harmonic voltage-current phase difference CH1 - CH3 1st - 50th
	AvePsum(1),...,AvePsum(50)	Harmonic power sum 1st - 50th
	AvePhasesum(1),...,AvePhasesum(50)	Harmonic voltage-current phase difference sum 1st - 50th
	AveUtihd1,...,AveUtihd4	Total harmonic voltage distortion factor CH1 - CH4
	AveItihd1,...,AveItihd4	Total harmonic current distortion factor CH1 - CH4
	AveU1(0.5),...,AveU4(49.5)	Inter-harmonic voltage CH1 - CH4 0.5 - 49.5th
	AveI1(0.5),...,AveI4(49.5)	Inter-harmonic current CH1 - CH4 0.5 - 49.5th

ΔV_{10} Flicker Text Time-sequence Data-header Composition

Classification	Header	Explanation	Example
Date and Time	Date	Date	2001/11/02
	Time	Time	17:19:00
ΔV_{10}	dv10	ΔV_{10} instantaneous value	0.081
	max	ΔV_{10} total maximum value	0.158
	dv10max	ΔV_{10} maximum value for one hour	0.000
	dv10max4	ΔV_{10} fourth largest value for one hour	0.000
	dv10ave	ΔV_{10} average value for one hour	0.000

IEC Flicker Text Time-sequence Data-header Composition

Classification	Header	Explanation	Example
Date and Time	Date	Date	2002/3/5
	Time	Time	15:24:15
Pst, Plt	Pst 1	CH1 Pst	0.325
	Pst 2	CH2 Pst	0.386
	Pst 3	CH3 Pst	0.358
	Plt 1	CH1 Plt	0.325
	Plt 2	CH2 Plt	0.386
	Plt 3	CH3 Plt	0.358

Text Event Waveform Data Format Composition

1	2001/11/02 17:19:00								Date, Time
2	U_1	I_1	U_2	I_2	U_3	I_3	U_4	I_4	Header (channel)
3 . 3586 or 4098									Measurement data

Text Voltage Fluctuation Event Data Format Composition

1	2001/11/02 17:19:00			Date, Time
2	U_1	U_2	U_3	Header (channel)
3 . 1002 or 1202				Measurement data

Text Event Data-format Composition

Example

No. 3:

2001/10/12 13:08:35.354, Dip CH1,OUT,0.24V,0:00:02.342

Event number (7+line feed, 2)	(Space)(3)	Date (10) *1	(Space) (1)	Time (up to ms) (12) *2	" "	Event category *3	(Space)	CH&Order *4	" "	IN/OUT *5	" "	Threshold (6) *6	" "	Peak, deepest value (6) *7	" "	Period (13) *8	Line feed (2)
----------------------------------	------------	-----------------	-------------	-------------------------------	-----	-------------------	---------	----------------	-----	--------------	-----	---------------------	-----	----------------------------------	-----	-------------------	---------------

Items	Example	Number of characters	():number of characters
*1. Date	2000/8/22	10	
*2. Time (up to ms)	13:08:35.354	12	
*3. Event category			
Items	Number of characters	Items	Number of characters
Tran	Transient	Unbalance(U)	Voltage unbalance factor
Swell	Voltage swell	Unbalance(I)	Current unbalance factor
Dip	Voltage dip	Uharm	Harmonic voltage
Intrupt	Interruption	lharm	Harmonic current
Freq	Voltage frequency	Pharm	Harmonic power
U(rms)	RMS voltage value	Pharm(phase)	Harmonic voltage-current phase difference
U(peak+)	Voltage waveform peak (+)	UTHD	Total harmonic voltage distortion factor
U(peak-)	Voltage waveform peak (-)	ITHD	Total inter-harmonic current distortion factor
I(rms)	RMS current value	KF	K factor
I(peak+)	Current waveform peak (+)	Wave	Waveform distortion
I(peak-)	Current waveform peak (-)	Ext(I/O)	External input
P(P)	Active power	Ext(start)	Start
P(S)	Apparent power	Ext(stop)	Stop
P(Q)	Reactive power		
PF	Power factor/Displacement power factor		
*4. CH&Order			
Items	Number of characters		
CH1,...,CH4	3		
CHsum	5		
CH1(1),...,CH1(50)	CH(harmonic order)		
CHsum(1),...,CHsum(50)	CHsum(harmonic order)		
*5. IN/OUT			
Items	Number of characters		
IN	Event start	2	
OUT	Event end	3	
SENSE	Sense event	5	
*6. Threshold	Displayed only when the status is "IN"	6	
7. Peak, deepest value	Display transient, dip, swell*, interruption*, sense event only (*:Displayed only when the status is "OUT")	6	
*8. Period	Displayed only when the status is "OUT"	13	

NOTE:

IN/OUT, thresholds, peak/deepest value, period, and their accompanying commas (,) are not displayed for some events.

Contents of Automatic Setting of Events (thresholds)

Items		Default setting of ON/OFF Only those lines used in the set wire connection are ON; the remainder are OFF. CH4 is OFF when AC is set.	Setting of levels The current measured values shall be used as the reference values. All hystereses should be 1% of the levels (thresholds). The levels (thresholds) are as specified below.
Transient overvoltage		ON	150% of the reference value (RMS voltage value)
Voltage swell		ON	110% of the nominal voltage value
Voltage dip		ON	90% of the nominal voltage value
Interruption		ON	10% of the nominal voltage value
Waveform distortion		ON	5% of the range
Frequency		ON	±5Hz of the reference value (frequency)
RMS voltage value		ON (SENSE OFF, SENSE width 10 V)	±10% of the reference value (RMS voltage value)
Voltage waveform peak (max)		ON	150% of the reference value (maximum voltage waveform peak value)
Voltage waveform peak (min)		ON	150% of the reference value (minimum voltage waveform peak value)
RMS current value		ON	±50% of the reference value (RMS current value)
Current waveform peak (max)		ON	200% of the reference value (maximum current waveform peak value)
Current waveform peak (min)		ON	200% of the reference value (minimum current waveform peak value)
Active power (The final ch is the SUM value.)		ON	150% of the absolute value of the reference value (active power)
Apparent power (The final ch is the SUM value.)		ON	150% of the absolute value of the reference value (apparent power)
Reactive power (The final ch is the SUM value.)		ON	150% of the absolute value of the reference value (reactive power)
Power factor (The final ch is the SUM value.)		ON	If lower than 70%
K factor		ON	If higher than 10
Voltage unbalance factor		ON	If higher than 3%
Current unbalance factor		ON	If higher than 35%
Harmonic voltage	Fundamental wave	ON	110% of the absolute value of the reference value (fundamental wave of the harmonic voltage)
	Harmonic wave	ON only in odd-numbered order up to eleventh order. The remainder are OFF.	10% of the absolute value of the reference value (fundamental wave of the harmonic voltage)
Harmonic current	Fundamental wave	ON	150% of the absolute value of the reference value (fundamental wave of the harmonic current)
	Harmonic wave	ON only in odd-numbered order up to eleventh order. The remainder are OFF.	50% of the absolute value of the reference value (fundamental wave of the harmonic current)

Items		Default setting of ON/OFF Only those lines used in the set wire connection are ON; the remainder are OFF. CH4 is OFF when AC is set.	Setting of levels The current measured values shall be used as the reference values. All hystereses should be 1% of the levels (thresholds). The levels (thresholds) are as specified below.
Harmonic power	Fundamental wave	ON	150% of the absolute value of the reference value (fundamental wave of the harmonic power)
	Harmonic wave	ON only in odd-numbered order up to eleventh order. The remainder are OFF.	50% of the absolute value of the reference value (fundamental wave of the harmonic power)
Harmonic voltage-current phase difference	Fundamental wave	OFF	Absolute value of the reference value (fundamental wave of the harmonic voltage-current phase difference)
	Harmonic wave	OFF	
Total harmonic voltage distortion factor		ON	5%
Total harmonic current distortion factor		ON	20%

NOTE: In the voltage value, current value, and power value, however, 10% of the range shall be the level (threshold) if the reference value is not higher than 10% of the range.

Event Recording Sequence (Priority Order)

In sequence from higher event priority (prioritized in the sequence of items described)

1. Transient overvoltage (peak-wise sequence)
2. Interruption, voltage dip, voltage swell
 1. In sequence of OUT - IN
 2. If the items are the same, the event that shows a deeper deepest value (maximum value) is given priority.
 3. If the items and the deepest values (maximum values) are the same, the period-wise sequence is applied.
4. External input, voltage waveform distortion, frequency, RMS voltage value, Voltage unbalance factor
5. Voltage waveform peak, current waveform peak, RMS current value, active power, apparent power, reactive power, power factor, current unbalance factor, total harmonic voltage distortion factor, total harmonic current distortion factor
6. Harmonic voltage, Harmonic current, Harmonic power, Harmonic voltage-current phase difference, K factor

NOTE: CH and order are unrelated to priority. If the events have the same priorities, the queuing sequence is indeterminate.

Block Diagram (Analog)

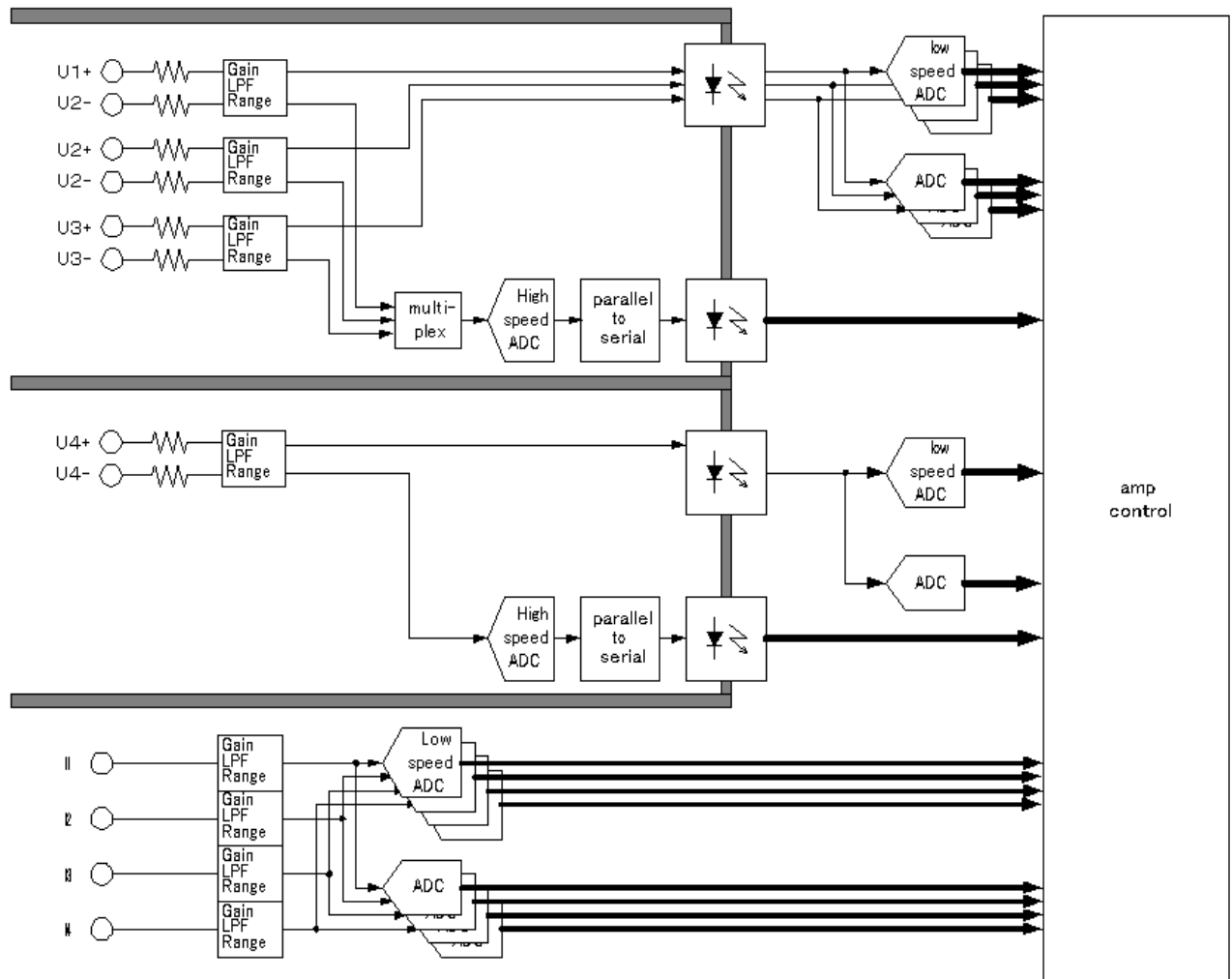

Block Diagram (Digital)

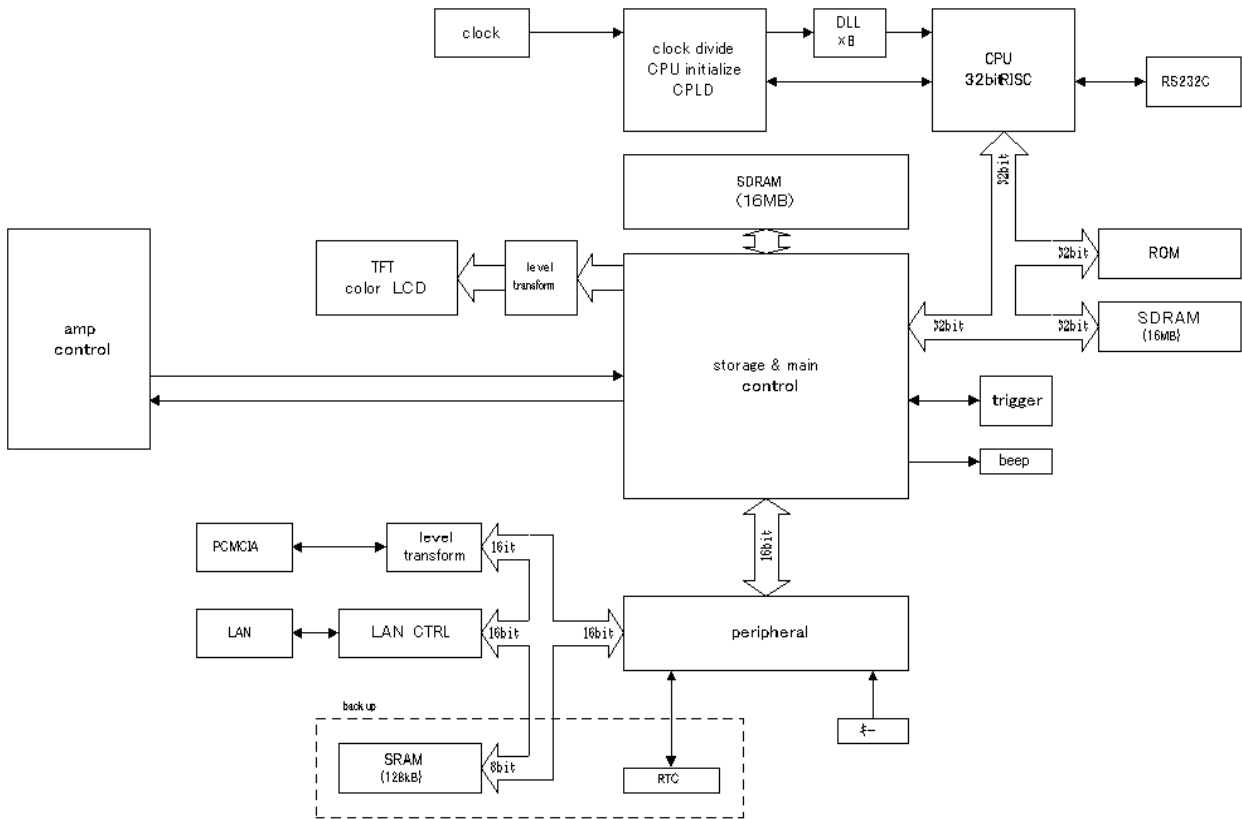

HIOKI 3196 POWER QUALITY ANALYZER
Instruction Manual

Publication date: October 2005 Revised edition 7

Edited and published by HIOKI E.E. CORPORATION
Technical Support Section

All inquiries to International Sales and Marketing Department
81 Koizumi, Ueda, Nagano, 386-1192, Japan

TEL: +81-268-28-0562 / FAX: +81-268-28-0568

E-mail: os-com@hioki.co.jp

URL <http://www.hioki.co.jp/>

Printed in Japan 3196A983-07

-
-
- All reasonable care has been taken in the production of this manual, but if you find any points which are unclear or in error, please contact your supplier or the International Sales and Marketing Department at HIOKI headquarters.
 - In the interests of product development, the contents of this manual are subject to revision without prior notice.
 - Unauthorized reproduction or copying of this manual is prohibited.
-
-

HIOKI ---

HIOKI E. E. CORPORATION

HEAD OFFICE

81 Koizumi, Ueda, Nagano 386-1192, Japan

TEL +81-268-28-0562 / FAX +81-268-28-0568

E-mail: os-com@hioki.co.jp / URL <http://www.hioki.co.jp/>

HIOKI USA CORPORATION

6 Corporate Drive, Cranbury, NJ 08512, USA

TEL +1-609-409-9109 / FAX +1-609-409-9108

3196A983-07 05-10H



Printed on recycled paper
