

INSTRUCTION MANUAL

**3285-20**

# **CLAMP ON AC/DC HiTESTER**

**HIOKI E. E. CORPORATION**

---

---



# Contents

Introduction .....	i
Verifying Package Contents .....	ii
Safety Information .....	iii
Operating Precautions .....	viii
Preliminary Check .....	xiii
Chapter 1 Overview .....	1
1.1 Product Overview .....	1
1.2 Features .....	2
1.3 Names and Functions of Parts .....	3
1.4 Flowchart of button Operations .....	10
1.4.1 Current Measurements Mode .....	10
1.4.2 Voltage Measurements Mode .....	11
1.4.3 Frequency Measurements Mode .....	12
1.4.4 Resistance Measurements Mode .....	12
1.5 Modes .....	13
Chapter 2 Measurement .....	15
2.1 Preparations .....	15
2.1.1 Installing or Replacing the Battery .....	15
2.1.2 Attaching the Hand Strap .....	16
2.1.3 Turning the Power On and Off .....	16
2.1.4 Battery Low Warning (When  mark lights) .....	17
2.1.5 Pre-Operation Inspection .....	18

2.2	Current Measurement .....	19
2.2.1	Measuring DC Current (DC A) .....	19
2.2.2	Measuring AC Current (AC A) .....	20
2.2.3	Measuring AC/DC Current (AC+DC A) .....	22
2.2.4	Peak Hold Measurement .....	24
2.3	Voltage Measurement .....	26
2.3.1	Measuring DC Voltage (DC V) .....	26
2.3.2	Measuring AC Voltage (AC V) .....	27
2.3.3	Measuring AC/DC Voltage (AC+DC V) .....	28
2.3.4	Peak Hold Measurement .....	29
2.4	Frequency Measurement .....	31
2.4.1	Frequency Measurement in Current Mode ·	31
2.4.2	Frequency Measurement in Voltage Mode ·	32
2.5	Resistance Measurement .....	34
2.6	Continuity Check .....	36
Chapter 3 Useful Functions .....		39
3.1	Adjusting and Correcting Values .....	39
3.1.1	Auto-Zero-Adjustment Function .....	39
3.1.2	Zero-Cancel Correction Function .....	40
3.2	Pausing and Reading the Display (Data Hold Function HOLD) .....	41
3.3	Alteration of Counter Updates .....	42
3.3.1	SLOW mode .....	42
3.3.2	FAST mode .....	42
3.4	Storing Values in Memory (Recording Function REC) .....	43
3.5	Automatically Turning Power Off (Auto Power-Off Function APS) .....	47
3.6	Beep Tone .....	48

Chapter 4 Specifications .....	49
4.1 Measurement Specifications .....	49
4.1.1 Current Measurement Specifications .....	49
4.1.2 Voltage Measurement Specifications .....	52
4.1.3 Resistance Measurement Specifications .....	54
4.1.4 Continuity Check .....	54
4.2 General Specifications .....	55
Chapter 5 Maintenance and Service .....	59
5.1 Cleaning .....	59
5.2 After service .....	59
5.3 Troubleshooting .....	60
5.4 Error Message .....	64



---

## Introduction

Thank you for purchasing the HIOKI "3285-20 CLAMP ON AC/DC HiTESTER."

To obtain maximum performance from the instrument, please read this manual first, and keep it handy for future reference.

### Request

We have tried to bring this manual as close to perfection as we could achieve. If perchance you find any unclear portions, mistakes, omissions, or the like, we would be most obliged if you could please notify us of them via any HIOKI agent, or directly.

---

## Verifying Package Contents

When you receive the instrument, inspect it carefully to ensure that no damage occurred during shipping. In particular, check the accessories, panel switches, and connectors.

If damage is evident, or if it fails to operate according to the specifications, contact your dealer or Hioki representative.

### Main unit

3285-20 CLAMP ON AC/DC HiTESTER

### Supplied accessories

9345 CARRYING CASE	1
9207-10 TEST LEAD (red and black)	1
Hand Strap	1
Battery 6F22(006P)	1
Instruction manual	1



---









## Safety Information







**This instrument is designed to comply with IEC 61010 Safety Standards, and has been thoroughly tested for safety prior to shipment. However, mishandling during use could result in injury or death, as well as damage to the instrument. Be certain that you understand the instructions and precautions in the manual before use. We disclaim any responsibility for accidents or injuries not resulting directly from instrument defects.**

This manual contains information and warnings essential for safe operation of the instrument and for maintaining it in safe operating condition. Before using it, be sure to carefully read the following safety precautions.

## Safety Symbols

	<p>The  symbol printed on the instrument indicates that the user should refer to a corresponding topic in the manual (marked with the  symbol) before using the relevant function.</p> <p>In the manual, the  symbol indicates particularly important information that the user should read before using the instrument.</p>
	Indicates both DC (Direct Current) and AC (Alternating Current).
	Indicates DC (Direct Current).
	Indicates a double-insulated device.
	Indicates a grounding terminal.
	Indicates that the instrument may be connected to or disconnected from a live circuit.

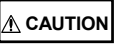
The following symbols in this manual indicate the relative importance of cautions and warnings.

	<p>Indicates that incorrect operation presents extreme danger of accident resulting in death or serious injury to the user.</p>
	<p>Indicates that incorrect operation presents a significant hazard that could result in serious injury or death to the user.</p>
	<p>Indicates that incorrect operation presents a possibility of injury to the user or damage to the instrument.</p>
	<p>Indicates advisory items related to performance or correct operation of the instrument.</p>

## Accuracy

We define measurement tolerances in terms of f.s. (full scale), rdg. (reading) and dgt. (digit) values, with the following meanings:

- f.s. (maximum display value or scale length)  
The maximum displayable value or scale length.  
This is usually the name of the currently selected range.
- rdg. (reading or displayed value)  
The value currently being measured and indicated on the measuring instrument.
- dgt. (resolution)  
The smallest displayable unit on a digital measuring instrument, i.e., the input value that causes the digital display to show a "1" as the least-significant digit.

---

## Measurement categories (Overvoltage categories)

This instrument complies with CAT III safety requirements.

To ensure safe operation of measurement instruments, IEC 61010 establishes safety standards for various electrical environments, categorized as CAT I to CAT IV, and called measurement categories. These are defined as follows.

- CAT I Secondary electrical circuits connected to an AC electrical outlet through a transformer or similar device.
- CAT II Primary electrical circuits in equipment connected to an AC electrical outlet by a power cord (portable tools, household appliances, etc.)
- CAT III Primary electrical circuits of heavy equipment (fixed installations) connected directly to the distribution panel, and feeders from the distribution panel to outlets.
- CAT IV The circuit from the service drop to the service entrance, and to the power meter and primary overcurrent protection device (distribution panel).

Higher-numbered categories correspond to electrical environments with greater momentary energy. So a measurement device designed for CAT III environments can endure greater momentary energy than a device designed for CAT II.

Using a measurement instrument in an environment designated with a higher-numbered category than that for which the instrument is rated could result in a severe accident, and must be carefully avoided.

Never use a CAT I measuring instrument in CAT II, III, or IV environments.

The measurement categories comply with the Overvoltage Categories of the IEC60664 Standards.

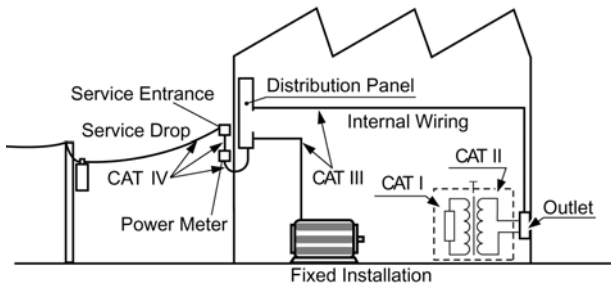



## Operating Precautions

Follow these precautions to ensure safe operation and to obtain the full benefits of the various functions.



- **To avoid short circuits and potentially life-threatening hazards, never attach the clamp to a circuit that operates at more than 600 Vrms.**
- **The maximum rated voltage to earth is 600 Vrms. Attempting to measure voltage in excess of the maximum rated voltage to earth could destroy the instrument and result in personal injury or death.**
- **This instrument should only be connected to the secondary side of a breaker, so the breaker can prevent an accident if a short circuit occurs. Connections should never be made to the primary side of a breaker, because unrestricted current flow could cause a serious accident if a short circuit occurs.**
- **To avoid electric shock, do not touch the portion beyond the protective barrier during use.**

 **DANGER**

- **Never apply voltage to the test leads when the Resistance measurement, Continuity Check modes are selected. Doing so may damage the instrument and result in personal injury. To avoid electrical accidents, remove power from the circuit before measuring.**

 **WARNING**

- **Do not allow the instrument to get wet, and do not take measurements with wet hands. This may cause an electric shock.**
- **To avoid electric shock when measuring live lines, wear appropriate protective gear, such as insulated rubber gloves, boots and a safety helmet.**
- **During current measurement, to avoid an electric shock accident, do not connect the test leads or temperature probe to the instrument.**
- **Input voltage exceeding 600 Vrms (1000 V max.) with respect to ground could damage the instrument and result in personal injury.**
- **Be sure to insert them with the correct polarity. Otherwise, poor performance or damage from battery leakage could result.**

 **WARNING**

- **To avoid electric shock when replacing the battery, first disconnect the clamp from the object to be measured.  
After replacing the battery, replace the cover and screws before using the instrument.**
- **To avoid the possibility of explosion, do not short circuit, disassemble or incinerate batteries.**
- **Handle and dispose of batteries in accordance with local regulations.**
- **Do not use the instrument where it may be exposed to corrosive or combustible gases.  
The instrument may be damaged or cause an explosion.**

 **CAUTION**

- Do not store or use the instrument where it could be exposed to direct sunlight, high temperature or humidity, or condensation. Under such conditions, the instrument may be damaged and insulation may deteriorate so that it no longer meets specifications.
- This instrument is designed for use indoors. It can be operated at temperatures between 0 and 40°C without degrading safety.
- Keep the clamp jaws and core slits free from foreign objects, which could interfere with clamping action.



**⚠ CAUTION**

- For safety reasons, when taking measurements, only use the 9207-10 TEST LEAD provided with the instrument.
- To avoid damage to the instrument, do not exceed the maximum input current rating, which depends on the frequency of the current being measured (see Fig.3 of 4.4.1) Be careful about the evolution of heat, when the input frequency is high.
- The **B** indicator appears when battery voltage becomes low. Replace the batteries as soon as possible.
- When replacing the battery, make sure that the metal battery snap fitting is firmly connected. If the metal fitting is loose, adjust it and recheck the connection. If it isn't connected securely, the power may not be turned on, and a power may be turned off during the use.
- Calibration and repair of this instrument should be performed only under the supervision of qualified technicians knowledgeable about the dangers involved.
- To avoid damage to the instrument, protect it from physical shock when transporting and handling. Be especially careful to avoid physical shock from dropping.  
Do not exert excessive pressure on the clamp sensor or attempt to wedge the sensor into a tight spot for measurement.

**⚠ CAUTION**

- The protection rating for the enclosure of this device (based on EN60529) is \*IP40.

\*IP40:

This indicates the degree of protection provided by the enclosure of the device against use in hazardous locations, entry of solid foreign objects, and the ingress of water.

4: Protected against access to hazardous parts with wire measuring 1.0 mm in diameter. The equipment inside the enclosure is protected against entry by solid foreign objects larger than 1.0 mm in diameter.

0: The equipment inside the enclosure is not protected against the harmful effects of water.

**NOTE**

- Correct measurement may be impossible in the presence of strong magnetic fields, such as near transformers and high-current conductors, or in the presence of strong electromagnetic fields such as near radio transmitters.
- To avoid corrosion from battery leakage, remove the batteries from the instrument if it is to be stored for a long time.

---

## Preliminary Check

Before using the instrument the first time, verify that it operates normally to ensure that the no damage occurred during storage or shipping. If you find any damage, contact your dealer or Hioki representative.



**Before using the instrument, make sure that the insulation on the test leads is undamaged and that no bare conductors are improperly exposed. Using the instrument in such conditions could cause an electric shock, so contact your dealer or Hioki representative for replacements. (Model 9207-10 TEST LEAD).**



---

---

# Chapter 1

## Overview

---

---

### 1.1 Product Overview

The 3285-20 CLAMP ON AC/DC HiTESTER makes it possible to measure DC, AC or AC+DC current in live power lines without tapping into or connecting the lines.

And it is also possible to measure voltage, frequency and resistance, and check circuit continuity.

## 1.2 Features

- Large current measurement  
Allows measurement of large current up to 2000 A.
  
- Display of true rms values  
The true rms value conversion circuit allows accurate measurement of currents with distorted waveforms.
  
- Measurement for AC/DC  
The instrument permits measurement of AC superimposed on DC, as well as measurement of half- and full-wave rectification.
  
- Peak measurement  
Allows measurement of peak hold values for either voltage or current. Transitional peak values can also be measured.
  
- REC function  
Displays the maximum and minimum measured values.

## 1.3 Names and Functions of Parts

3285-20

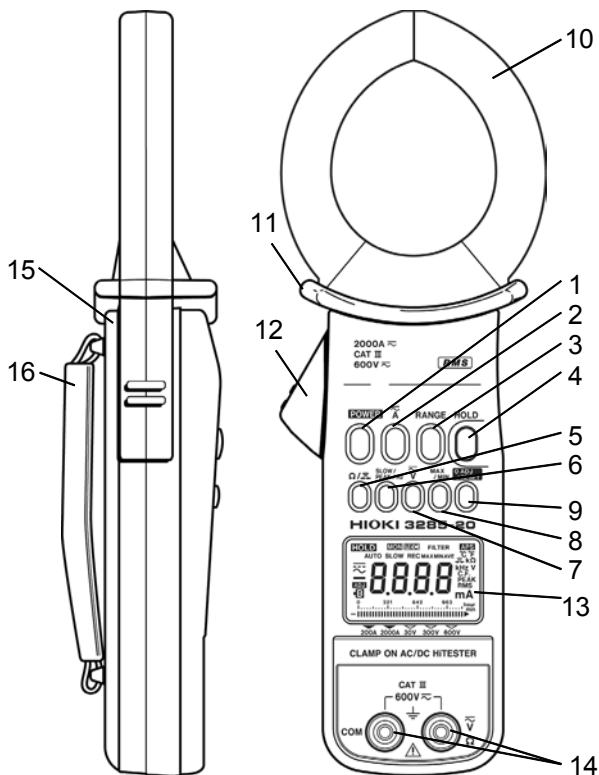

**1 POWER**

- Used to turn power on/off
- To disable the auto power-off function, hold **HOLD** and press **POWER**, when you turn power on.

**2  button**

Switches current modes as follow.

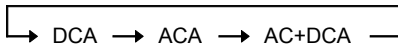
**3 RANGE button**

- Switches between auto and manual ranges in measurements of current, voltage, or frequency.
- Switches manual ranges.
- Displays a cursor on the bar graph to show the selected range.
- The current ranges are 200 A and 2000 A. The voltage ranges are 30 V, 300 V and 600 V. The frequency ranges are 10 Hz, 100 Hz and 1000 Hz.
- Auto-ranging is used for resistance measurement.

**4 HOLD button**

- Used to suspend or inactivate the screen-updating function.
- To disable the auto power-off function when powering on, hold **HOLD** button and press **POWER** button.



5  button

Switches between resistance measurement and continuity checking.

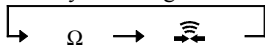
6  button

- **SLOW** slows down screen updating speed (once per three seconds).
- **FAST** speeds up screen updating speed (four times per second). There isn't an annunciator "". Instead, the unit symbol blinks.
- **PEAK** measures peak values (Peak Hold).
- **Hz** measures frequency (in AC or AC+DC mode).

7  button

Switches voltage modes as follows.

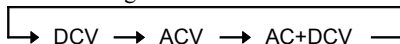
8  button

- Displays the maximum value (**MAX**), the minimum value (**MIN**), or the average value (**AVE**) of the maximum and minimum values for the recording (**REC**) function.
- **MAX** displays the maximum measured value after the **REC** function is activated.
- **MIN** displays the minimum measured value after the **REC** function is activated.
- **AVE** displays the average value of the maximum and minimum measured values after the **REC** function is activated.
- The auto power-off function is disabled.
- Not available during resistance measurement.

**9 0ADJ/RESET**

- Performs auto-zero-adjustment in DC A, AC+DC A and DC V modes.
- Resets data when measuring peak values. Reset all the data in a **REC** function.
- If zero is not indicated under no input in the AC A, AC+DC A, AC V or AC+DC V modes, press **HOLD** , then press **0ADJ/RESET** to perform a zero-cancel correction.

**10 Clamp sensor**

To measure current, open the top ends of the clamp sensor by gripping the lever 12. Then position the conductor to be measured at the center of the clamp sensor and firmly close the clamp sensor.

**11 Protective barrier**

Be careful to not touch the clamp sensor beyond the safety barrier when clamping onto a conductor for measurement.



**12 Lever**

Used to open and close the clamp sensor.

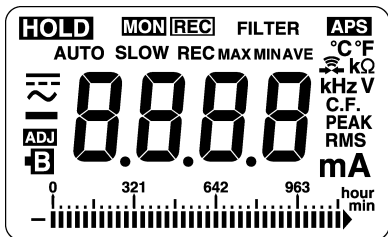
## 13 Display (LCD)



	Direct Current (DC)
	Alternating Current (AC)
	Alternating Current and Direct Current (AC+DC)
<b>ADJ</b>	Auto-zero-adjustment or zero-cancel correction function is active
<b>B</b>	Battery low warning
<b>HOLD</b>	Data hold function
<b>APS</b>	Auto power off function
<b>AUTO</b>	Auto-range
<b>SLOW</b>	Counter update once every 3 seconds
<b>REC</b>	Record function
<b>MAX</b>	Maximum value
<b>MIN</b>	Minimum value
<b>AVE</b>	Average value = $(\text{MAX} + \text{MIN}) / 2$

<b><math>\Omega</math></b>	Resistance
	Continuity
<b>Hz</b>	Frequency
<b>V</b>	Voltage
<b>PEAK</b>	Wave peak value
<b>RMS</b>	True root mean square value
<b>A</b>	Current
<b>hour</b>	1 hour/segment (bar graph)
<b>min</b>	1 minute/segment (bar graph)
	Input over (bar graph)

14 Voltage/resistance input terminal (V,  $\Omega$ , and COM terminals)

Connected to the 9207-10 TEST LEAD (red and black, supplied with the instrument) to measure voltage or resistance.

15 Back case

To replace the battery, remove the two screws.

16 Hand strap

Attach to get a better grip on the instrument.

---

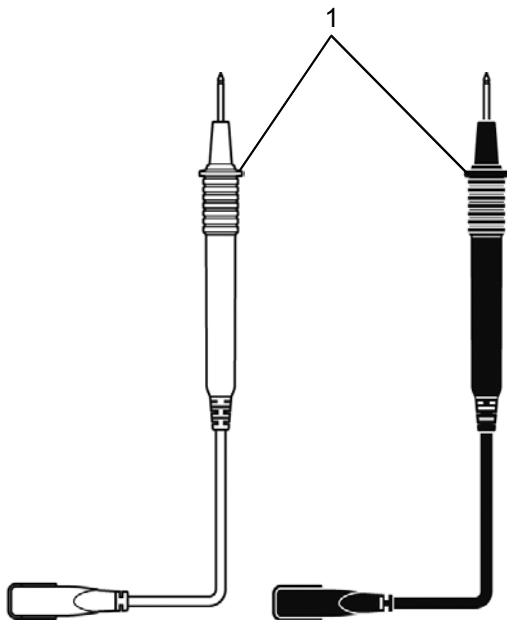
**9207-10**

### 1 Protective barrier

Be careful to not touch the metal part of the test lead beyond the safety barrier when contacting a conductor for measurement.

## 1.4 Flowchart of button Operations

### 1.4.1 Current Measurements Mode

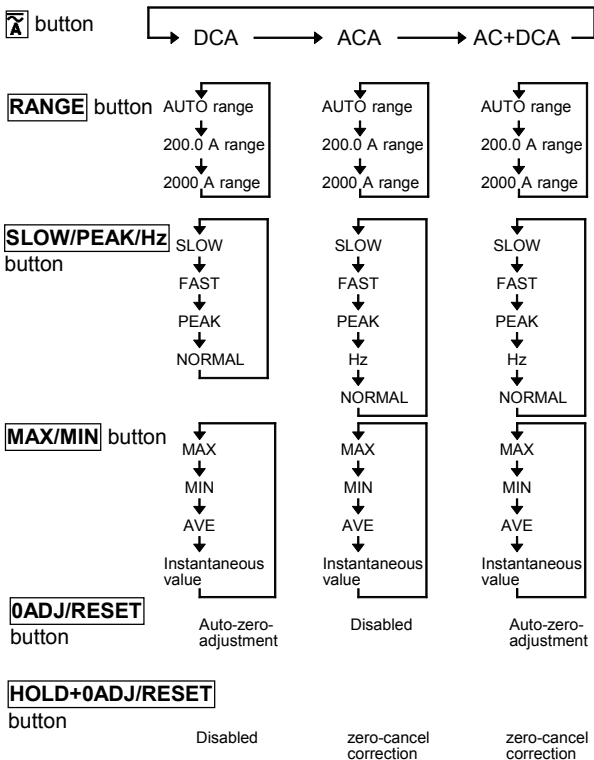

\* Neither "FAST" or "NORMAL" annunciator is on the display.

## 1.4.2 Voltage Measurements Mode

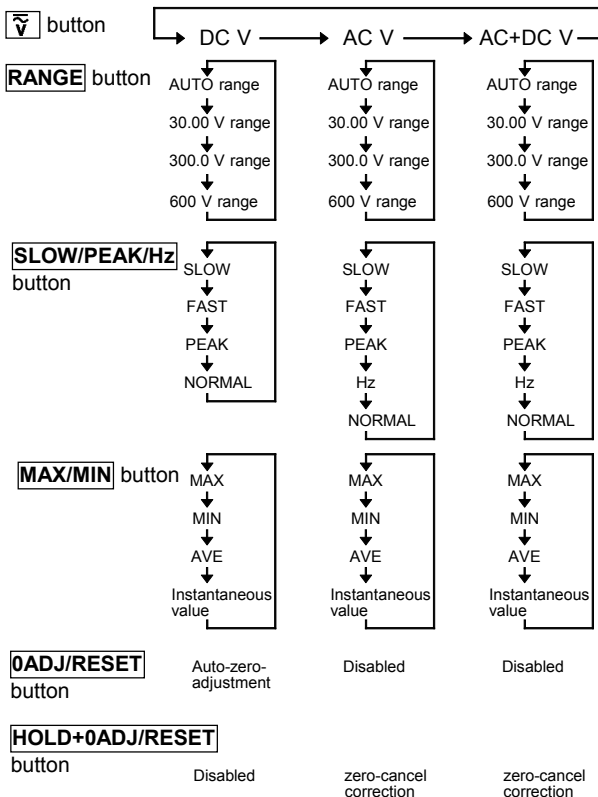

\* Neither "FAST" or "NORMAL" annunciator is on the display.

### 1.4.3 Frequency Measurements Mode

Current (AC A, AC+DC A) mode

Voltage (AC V, AC+DC V) mode

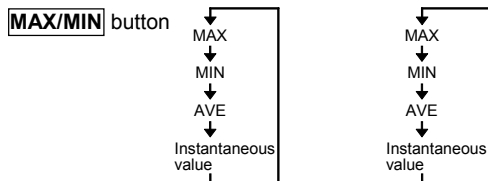
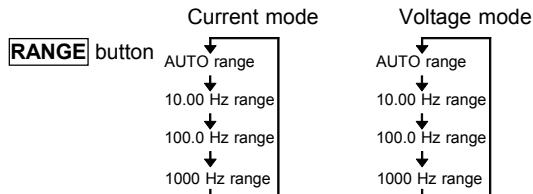
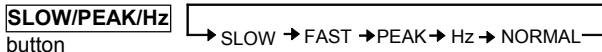

**0ADJ/RESET** button

Disabled

Disabled



### 1.4.4 Resistance Measurements Mode

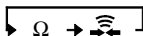











**$\Omega$ /↕** button





## 1.5 Modes

For voltage and current, three modes are provided: DC (direct current, ) , AC (alternating current, ) , and AC+DC (alternating current and direct current, ) modes. Select a proper mode according to the waveform shown below:

Mode	Input waveform	Display
DC (  )		<input type="radio"/> Average value displayed (with polarity)
		<input checked="" type="checkbox"/> Not measurable
		<input checked="" type="checkbox"/> Not measurable
AC (  )		<input checked="" type="checkbox"/> Not measurable (zero displayed)
		<input type="radio"/> RMS value
		<input checked="" type="checkbox"/> Not measurable
AC+DC (  )		<input type="radio"/> RMS value (without polarity)
		<input type="radio"/> RMS value
		<input type="radio"/> RMS value



---

## Chapter 2

# Measurement

---

---

### 2.1 Preparations

---

#### 2.1.1 Installing or Replacing the Battery

 **CAUTION**

Do not fix the back casing screws too tightly.  
The torque about 0.5N·m is recommended.

1. Remove the two fastening screws of the rear cover, using a Phillips screwdriver.
2. Remove the rear cover.
3. Remove the old battery without pulling the codes of the snap.
4. Securely connect the battery to the battery snap.
5. Replace the rear cover and tighten the fastening screws.

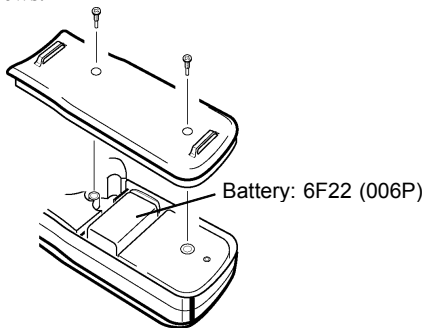

## 2.1.2 Attaching the Hand Strap

Explains how to attach the hand strap, for easy handling of the instrument in the field.

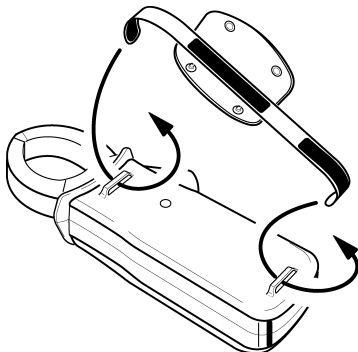

## 2.1.3 Turning the Power On and Off

### Power ON

1. Press **POWER** to turn the instrument on. Verify that all segments of the display light up briefly. Then the model name is shown, and the bar graph indicates the battery condition.

 Fresh battery

 Battery capacity 50%

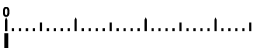
 Battery capacity 0 **B**  
 Beep tone sounds 3 times

2. The DC current measurement mode is activated.

---

## Power OFF

1. Press **POWER** to turn the instrument off.

---

### 2.1.4 Battery Low Warning (When **B** mark lights)

- When this annunciator lights, the battery is exhausted. Under such condition, the measurement value may be incollect. Replace a new battery.
- To check remaining battery life, check the bar graph, when powering on. (See 2.1.3: Turning the Power On and Off) The bar graph provides a rough approximation of remaining battery life. Be careful for the battery life especially when using the REC function.
- Batteries tend to increase in voltage somewhat when left unused for a long period. Even if the battery warning annunciator becomes temporarily off after the period, replace the battery as soon as possible. If the battery is not replaced at this point in time, the annunciator may not light up immediately on the next occasion. Replace a new battery before it ruins a measurement or causes some other inconvenience. (See 2.1.1: Installing or Replacing the Battery)

## Low battery voltage detection function

After the **B** mark lights and battery voltage drops below a certain level, the power goes off automatically. When this occurs, **bAtt** and **Lo** are displayed.

When power goes off after display of these marks, replace the exhausted battery with a new one.

## 2.1.5 Pre-Operation Inspection

Confirm the following before using the meter:

- **The tips of the clamp-on sensor must not be deformed.**  
(Correct measurement may be impossible if the tips are deformed.)
- **The clamp-on sensor must not be cracked or damaged, and there must be no bare metal exposed.**  
(To avoid electric shock, do not use a clamp-on sensor with cracks or other damage, or exposed metal.)
- **The meter must be undamaged.**  
(To avoid electric shock, do not use the meter if it is damaged.)
- **Test lead insulation must not be scratched or torn, and there must be no metal exposed.**  
(If damage is found, to avoid electric shock, replace with Model 9207-10.)
- **The batteries should be in good condition when power is turned on.**  
("B" is displayed when battery voltage is low, and correct measurement may be impossible.)
- **The display should show close to 0 A in ACA mode.**
- **In DCA mode, pressing the **0ADJ/RESET** button should display close to 0 A.**
- **In ACV mode, shorting the test leads should display close to 0 V.**
- **In  $\Omega$  mode, shorting the test leads should display close to 0  $\Omega$ .**

---

---

## 2.2 Current Measurement

**NOTE**

- Correct measurement may be impossible in the presence of strong magnetic fields, such as near transformers and high-current conductors, or in the presence of strong electromagnetic fields such as near radio transmitters.
- Attach the clamp around only one conductor. Single-phase (2-wire) or three-phase (3-wire) cables clamped together will not produce any reading.
- The display may show a measured value bigger than the actual value due to a magnetic field interference. The interference is less than 2 A during the measurement.

---

### 2.2.1 Measuring DC Current (DC A)

1. Press  button to display  $\overline{\text{A}}$ .
2. Switch between the auto range and the manual range as necessary.
3. Press **0ADJ/RESET** button to make an auto-zero-adjustment (without clamping the measured conductor inside the clamp sensor) with the clamp sensor firmly closed. (See 3.1.1: Auto-Zero-Adjustment Function). **ADJ** annunciator lights to indicate that auto-zero-adjustment is complete. (If you make an auto-zero-adjustment in the auto range, two current ranges will be adjusted in this mode.)

4. Open the top ends of the clamp core, orient the current direction indicator on the clamp in the current direction of the measured conductor, and clamp the conductor so that it passes through the center of the clamp core.

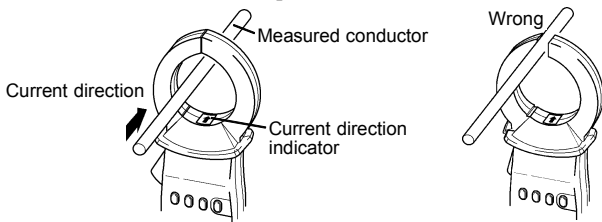
**NOTE**

- The DC A mode permits only DC current measurements that does not include the AC component (See 1.5: Modes).
- The 200 A range will display up to 250 A, however, only the range from 10 A to 200 A can be displayed with guaranteed accuracy.
- At any range, gross errors may occur at 1% or below of the range, whose accuracy is not guaranteed, as a result of internal corrective calculations.

## 2.2.2 Measuring AC Current (AC A)

1. Press  button to display  $\sim$ .
2. Switch between the auto range and the manual range as necessary.
3. Open the top ends of the clamp core and clamp the measured conductor so that it passes through the center of the clamp core.



**NOTE**

- Just after suspension of input, or when modes are switched under no input, the counter would not become zero for about 10 seconds. This is normal and simply reflects the workings of the internal circuit. But you can measure with guaranteed accuracy before the counter becomes zero.
- Depending on ambient temperatures, the counter would not become zero under no input. If this happens, perform a zero-cancel correction (See 3.1.2: Zero-Cancel Correction Function).
- During a f.s. input, the measurement response speed is about 250 ms during rise (0% to 90%) and about 500 ms (100% to 10%) during fall (See: Figs. 1 and 2).
- The AC A mode does not allow measurement of DC waveforms, full-wave rectification waveforms, half-wave rectification waveforms, or DC+AC waveforms (See 1.5: Modes).
- The 200 A range will display up to 250 A, however, only the range from 10 A to 200 A can be displayed with guaranteed accuracy.
- At any range, gross errors may occur at 1% or below of the range, whose accuracy is not guaranteed, as a result of internal corrective calculations.

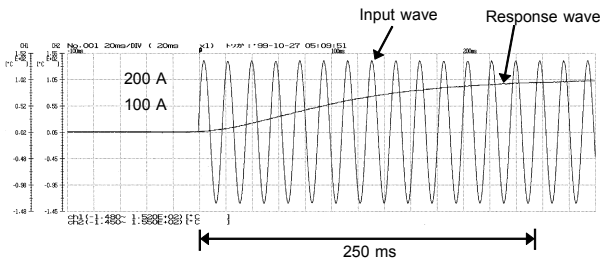

Fig. 1 Waveform of Measurement Response (Rise)

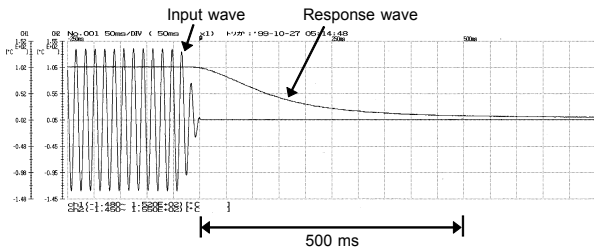



Fig. 2 Waveform of Measurement Response (Fall)

### 2.2.3 Measuring AC/DC Current (AC+DC A)

1. Press  button to display .
2. Switch between the auto range and the manual range as necessary.

3. Press **0ADJ/RESET** button to make an auto-zero-adjustment (without clamping the measured conductor inside the clamp sensor) with the clamp sensor firmly closed. (See 3.1.1: Auto-Zero-Adjustment Function). **ADJ** annunciator lights to indicate that auto-zero-adjustment is complete.
4. If the counter fails to become zero under no input, press **HOLD** button and then press **0ADJ/RESET** button to perform a zero-cancel correction.
5. Open the top ends of the clamp core and clamp the measured conductor so that it passes through the center of the clamp core.

**NOTE**

- Just after suspension of input, or when modes are switched under no input, the counter would not become zero for about 10 seconds. This is normal and simply reflects the workings of the internal circuit. But you can measure with guaranteed accuracy before the counter becomes zero.
- Depending on ambient temperatures, the counter would not become zero under no input. If this happens, perform a zero-cancel correction (See 3.1.2: Zero-Cancel Correction Function).
- The polarity of the input is not displayed, even if DC current is measured in this mode. If the clamp sensor is reoriented, the measured values may change, but the values are within the guaranteed accuracy. (In case that you would like to measure a DC current which doesn't have AC components, you should make the measurement in DC A mode.)
- During a f.s. input, the measurement response speed is about 250 ms during rise (0% to 90%) and about 500 ms (100% to 10%) during fall (See 2.2.2 Measuring AC Current (AC A), Figs. 1 and 2).

- The 200 A range will display up to 250 A, however, only the range from 10 A to 200 A can be displayed with guaranteed accuracy.
- At any range, gross errors may occur at 1% or below of the range, whose accuracy is not guaranteed as a result of internal corrective calculations.

## 2.2.4 Peak Hold Measurement

The peak value of measured current is retained on the display to simplify reading. Peak fluctuations can also be viewed.

1. Press  button and select a measurement mode for the measured circuit.
2. In DC A and AC+DC A modes, make an auto-zero-adjustment by **0ADJ/RESET** button (See 3.1.1: Auto-Aero Adjustment Function).
3. Set to **PEAK**. The measurement mode is switched by **SLOW/PEAK/Hz** button as follows.

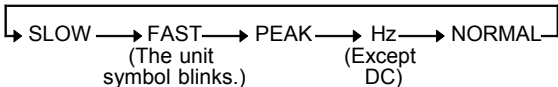

4. Switch between the auto and the manual range as necessary. (If you are unable to estimate the peak current value, start at the 2000A range.)
5. Before the measurement, press **0ADJ/RESET** button to reset the residual data.
6. Open the top ends of the clamp core and clamp the measured conductor so that it passes through the center of the clamp core.

**NOTE**

- The polarity of the input is not displayed during peak measurements. The measured values may change if the clamp sensor is reoriented, but the values are within the guaranteed accuracy.
- For peak measurements, internal resetting occurs every 250 ms. This may cause a peak detection failure, depending on the timing.
- Even after clamping, press **0ADJ/RESET** button to reset the data as necessary.
- In case that the counter doesn't become zero under no input in peak measurement mode, even though you pressed **0ADJ/RESET** button to reset the peak data, the clamp sensor may be magnetized. Quit the peak measurement mode, and perform the auto-zero adjustment by **0ADJ/RESET** button . Then make the settings again. (A few counts would remain, even if you push **0ADJ/RESET** button .)
- The hold value does not change, unless a larger value is measured, but be careful to avoid accidental loss of data resulting from the auto power-off function. (See 3.5: Automatically Turning Power off (Auto Power-Off Function APS))
- Use the REC function to make measurements longer than the auto power OFF time.
- To check transitional peak value, press **MAX/MIN** button to shift to the instantaneous value (no annunciator).

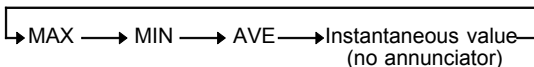



---

---

## 2.3 Voltage Measurement

 CAUTION

For safety reasons, when taking measurements, only use the 9207-10 TEST LEAD provided with the instrument.

---

### 2.3.1 Measuring DC Voltage (DC V)

1. Press  button to display  $\overline{\text{---}}$ .
2. Insert the red test lead to **V/ $\Omega$**  and the black test lead to **COM** of the voltage/resistance input terminal.
3. Switch between the auto range and the manual range as necessary.
4. In case that the counter isn't zero, press **0ADJ/RESET** button to make an auto-zero-adjustment. **ADJ** annunciator lights to indicate that auto-zero-adjustment is complete. (See 3.1.1: Auto-Zero-Adjustment Function)
5. Carefully contact the test leads to a circuit.

**NOTE**

- You can perform the auto-zero-adjustment up to 4% of the range.
- A lit - annunciator indicates that potential is higher at the black test lead than at the red test lead.

**NOTE**



- The DC V mode permits only DC voltage measurements that does not include the AC component (See 1.5: Modes).
- Every range will display up to 125% of the range, however, only the range from 10% to 100% can be displayed with guaranteed accuracy.
- At any range, gross errors may occur at 1% or below of the range, whose accuracy is not guaranteed, as a result of internal corrective calculations.

---

### 2.3.2 Measuring AC Voltage (AC V)

1. Press  to display  $\sim$ .
2. Insert the red test lead to **V/Ω** and the black test lead to **COM** of the voltage/resistance input terminal.
3. Switch between the auto range and the manual range as necessary.
4. Carefully contact the test leads to a circuit.



**NOTE**

- Just after suspension of input, or when modes are switched under no input, the counter would not become zero for about 10 seconds. This is normal and simply reflects the workings of the internal circuit. But you can measure with guaranteed accuracy before the counter becomes zero.
- Depending on ambient temperatures, the counter would not become zero under no input, if this happens, press  button and then press  button to perform a zero-cancel correction. (See 3.1.2: Zero-Cancel Correction Function)
- During a f.s. input, the measurement response speed is about 250 ms during rise (0% to 90%) and about 500 ms (100% to 10%) during fall (See 2.2.2: Measuring AC Current (AC A), Figs. 1 and 2).

**NOTE**

- The AC V mode does not allow measurement of DC waveforms, full-wave rectification waveforms, half-wave rectification waveforms, or DC+AC waveforms (See 1.5: Modes).
- Every range will display up to 125% of the range, however, only the range from 10% to 100% can be displayed with guaranteed accuracy.
- At any range, gross errors may occur at 1% or below of the range, whose accuracy is not guaranteed, as a result of internal corrective calculations.

### 2.3.3 Measuring AC/DC Voltage (AC+DC V)

1. Press  button to display  $\overline{\sim}$ .
2. Insert the red test lead to **V/Ω** and the black test lead to **COM** of the voltage/resistance input terminal.
3. Switch between the auto range and the manual range as necessary.
4. If the counter fails to become zero under no input, press  button and then press  button to perform a zero-cancel correction. (See 3.1.2: Zero-Cancel Correction Function)
5. Carefully contact the test leads to a circuit.

**NOTE**

- Just after suspension of input, or when modes are switched under no input, the counter would not become zero for about 10 seconds. This is normal and simply reflects the workings of the internal circuit. But you can measure with guaranteed accuracy before the counter becomes zero.
- The polarity of the input is not displayed, even if DC voltage is measured in this mode. If the connections of test leads are moved, the measured values may change, but the values are within the guaranteed accuracy. (In case that you would like to measure DC voltage which doesn't have AC components, you





should make the measurement in DC V mode.)

- During a f.s. input, the measurement response speed is about 250 ms during rise (0% to 90%) and about 500 ms (100% to 10%) during fall (See 2.2.2: Measuring AC Current (AC A), Figs. 1 and 2).
- Every range will display up to 125% of the range, however, only the range from 10% to 100% can be displayed with guaranteed accuracy.
- At any range, gross errors may occur at 1% or below of the range, whose accuracy is not guaranteed, as a result of internal corrective calculations.

### 2.3.4 Peak Hold Measurement

The peak value of measured voltage is retained on the display to simplify reading. Peak fluctuations can also be viewed.

1. Press  and select a measurement mode for the measured circuit.
2. Insert the red test lead to **V/Ω** and the black test lead to **COM** of the voltage/resistance input terminal.
3. Set to **PEAK**. The measurement mode is switched by  as follow.

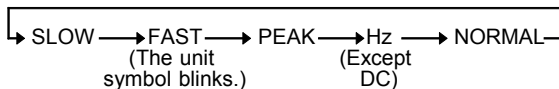

4. Switch between the auto and the manual range as necessary. (If you are unable to estimate the peak voltage value, start at the 600 V range.)
5. Before the measurement, press  button to reset the residual data.

**NOTE**

- The polarity of the input is not displayed during peak measurements. If the connections of test leads

are moved, the measured values may change, but the values are within the guaranteed accuracy.

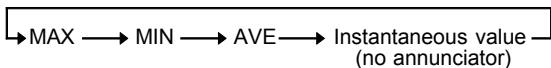

- For peak measurements, internal resetting occurs every 250 ms. This may cause a peak detection failure, depending on the timing.
- To check transitional peak value, press **MAX/MIN** button to shift to the instantaneous value (no annunciator).
- The zero adjustment is not effective at peak hold measurement mode.





## 2.4 Frequency Measurement

### 2.4.1 Frequency Measurement in Current Mode

1. Press  button and select **AC** or **AC+DC**, depending on the circuit to be measured.
2. If the current range of the measured circuit is known, set the current range to the manual range.
3.  button switches the annunciators as follows. Select Hz by pressing the button. (The unit symbol **A** blinks, and a current value is displayed on the bar graph.)

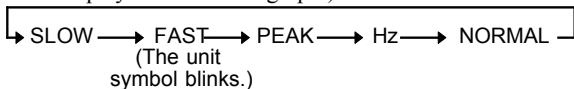

4. Switch the auto range and the manual range as necessary.
5. Open the top ends of the clamp core and clamp the measured conductor so that it passes through the center of the clamp core.

#### NOTE

- At the 100 Hz and 1000 Hz ranges, ---- appears on the counter when the frequency is lower than 10 Hz.
- ---- appears on the counter, if the frequency is lower than 1 Hz.
- **O. L.** appears on the counter, if the frequency is higher than 1 kHz.
- If an input value is significantly lower than the range, an accurate measurement may not be achieved, resulting in ----, **O. L.** or display fluctuations.

**NOTE**

- The 10 Hz range or 100 Hz range will display up to 125% of each range, however, only the range from 10% to 100% can be displayed with guaranteed accuracy.
- The frequencies, whose waveforms are special such as inverters, would not be measurable, when the carrier frequencies are lower than several kHz.
- Full-wave rectification indicates twice the actual value, due to an AC coupling in the internal circuit.
- It would take time to stabilize the counter, depending on the frequency range or the input frequency.

## 2.4.2 Frequency Measurement in Voltage Mode

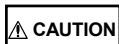

For safety reasons, when taking measurements, only use the 9207-10 TEST LEAD provided with the instrument.

1. Press  button and select **AC** or **AC+DC**, depending on the circuit to be measured.
2. If the voltage range of the measured circuit is known, set the voltage range to the manual range.
3. Insert the red test lead to **V/Ω** and the black test lead to **COM** of the voltage/resistance terminal.

4. **SLOW/PEAK/Hz** button switches the annunciators as follows. Select Hz by pressing the button. (The unit symbol **V** blinks, and a voltage value is displayed on the bar graph.)

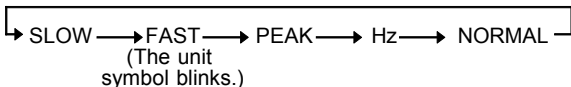

4. Switch between the auto range and the manual range as necessary.
5. Carefully contact the test leads to a circuit.

**NOTE**

- At the 100 Hz and 1000 Hz ranges, ---- appears on the counter when the frequency is lower than 10 Hz.
- ---- appears on the counter, if the frequency is lower than 1 Hz.
- **O. L.** appears on the counter, if the frequency is higher than 1 kHz.
- If an input value is significantly lower than the range, on accurate measurement may not be achieved, resulting in ----, **O. L.** or display fluctuations.
- The 10 Hz range or 100 Hz range will display up to 125% of each range, however, only the range from 10% to 100% can be displayed with guaranteed accuracy.
- The frequencies, whose waveforms are special such as inverters, would not be measurable, when the carrier frequencies are lower than several kHz.
- Full-wave rectification indicates twice the actual value, due to an AC coupling in the internal circuit.
- It would take time to stabilize the counter, depending on the frequency range or the input frequency.



---

---

## 2.5 Resistance Measurement

 **DANGER**

Never apply voltage to the test leads when the Resistance measurement mode is selected. Doing so may damage the instrument and result in personal injury.

To avoid electrical accidents, remove power from the circuit before measuring.

 **CAUTION**

For safety reasons, when taking measurements, only use the 9207-10 TEST LEAD provided with the instrument.

1. Press  button to display  $\Omega$ . Auto-ranging is used for resistance measurement.
2. Insert the red test lead to **V/Ω** and the black test lead to **COM** of the voltage/resistance terminal.
3. Touch the tips of the red and black test leads together and verify that  $0 \Omega$  is displayed.
4. Then connect the test leads to the test points for measurement.

**NOTE**

- If voltage is applied inadvertently, the internal circuitry is protected up to 600 VAC.
- If voltage larger than approximately 2 or 3 V is input, the Resistance measurement mode cannot be selected.
- If the display shows larger than 7 or 8 A at 200 A range in the DCA mode, the Resistance measurement mode cannot be selected. Press the **0ADJ/RESET** key to reset the display to 0.



---

---

## 2.6 Continuity Check



 **DANGER**

Never apply voltage to the test leads when the Continuity check mode is selected. Doing so may damage the instrument and result in personal injury.

To avoid electrical accidents, remove power from the circuit before measuring.

 **CAUTION**

For safety reasons, when taking measurements, only use the 9207-10 TEST LEAD provided with the instrument.

1. Press  button to display . Auto-ranging is used for continuity checking.
2. Insert the red test lead to **V/Ω** and the black test lead to **COM** of the voltage/resistance input terminal.
3. Touch the tips of the red and black test leads together and verify that **0 Ω** is displayed.
4. Then connect the test leads to the test points for measurement.  
The beeper sounds when the measured resistance is below about **30 Ω**.



**NOTE**

- If voltage is applied inadvertently, the internal circuitry is protected up to 600 VAC.
- The measured resistance value appears on the digital display.
- If voltage larger than approximately 2 or 3 V is input, the Continuity check mode cannot be selected.
- If the display shows larger than 7 or 8 A at 200 A range in the DCA mode, the Resistance measurement mode cannot be selected. Press the **0ADJ/RESET** key to reset the display to 0.



---

## Chapter 3

# Useful Functions

---

---

### 3.1 Adjusting and Correcting Values

---

#### 3.1.1 Auto-Zero-Adjustment Function

The auto-zero-adjustment function is used to adjust offsets in the internal circuit automatically that result from temperature characteristics or clamp sensor magnetization. The clamp core is magnetized during a large DC current measurement, or when a powerful magnet is placed close to the clamp core.

1. Wait until the counter is stable under no input. Then, press **0ADJ/RESET** button. **ADJ** annunciator lights.

**NOTE**

- You can perform the auto-zero-adjustment, if the counter displays within  $\pm 45$  A in a current mode.
- When there is an input or the counter decreases, the measurement accuracy will be spoiled by pressing 0ADJ/RESET as well as the accurate auto-zero-adjustment. If inaccurate auto-zero-adjustment is performed, perform the correct procedure again.
- It would take approximately 20 seconds to stabilize the counter in AC+DC A mode.

**NOTE**

- Use the zero-cancel correction function if the counter fails to revert to zero after correct auto-zero-adjustment in AC+DC A mode.
- In a current mode, if you press **0ADJ/RESET** button again during the auto-zero-adjustment in the internal circuit, the auto-zero-adjustment is canceled.
- The auto-zero-adjustment is not effective at auto range in DCV mode. If you perform the auto-zero-adjustment at manual range, the auto-zero-adjustment is invalid by changing the range.

---

### 3.1.2 Zero-Cancel Correction Function

Use the zero-cancel correction function when the counter fails to become zero under no input in AC A, AC+DC A, AC V, or AC+DC V mode.

1. Press **HOLD** button to display **HOLD** annunciator.
2. Press **0ADJ/RESET** button. **ADJ** annunciator blinks.

**NOTE**

- When there is an input or the counter decreases, the measured values will be evaluated lower by pressing **0AJD/RESET** button.
- If the counter is zero, the zero-cancel correction function does not work.
- In AC+DC A mode, the zero-cancel correction function does not work, unless auto-zero-adjustment is complete.
- The zero-cancel correction function is not effective at auto range in DCV mode. If you perform the zero-cancel correction at manual range, the zero-cancel correction is invalid by changing the range.

---

---

## 3.2 Pausing and Reading the Display (Data Hold Function **HOLD** )

This function freezes the counter at any desired point for easy reading.

1. Press **HOLD** button. **HOLD** annunciator lights on the display and the digital display value and bar graph display are maintained.  
If you press **RANGE** button during the data hold function, the bar graph display the present range. The data hold function is available for all measurements.
2. To cancel the data hold function, press **HOLD** button again.

---



---

### 3.3 Alteration of Counter Updates

The counter is updated twice per second when powering on. The counter update may be altered according to measurement conditions.

**SLOW/PEAK/Hz** button changes an annunciator as follows:

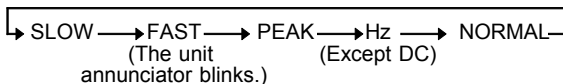

---

#### 3.3.1 SLOW mode

If the counter fluctuates rapidly and is hard to read, you can select a slower update rate (once every 3 seconds) by pressing **SLOW/PEAK/Hz** button.

---

#### 3.3.2 FAST mode

- For current measurements and voltage measurements, the counter is updated four times per second in FAST mode. You can measure abrupt changes such as starting currents.
- The unit symbol **A** or **V** blinks.
- To facilitate reading when measuring a starting current, use the record (**REC**) function to hold the maximum value (**MAX**).

---



---

## 3.4 Storing Values in Memory (Recording Function REC)

Use the recording function to hold the maximum and minimum measured values and maximum/minimum averages. (Not available for resistance measurements.)

### 1. Measurement indicated value

- Pressing the **MAX/MIN** button during measurements of current or voltage activates the recording function. **REC** flashes and the instrument saves the maximum value (MAX), minimum value (MIN), and average value (AVE) in internal memory from the instant you press the **MAX/MIN** button.
- Pressing the **MAX/MIN** button with the recording function activated switches the display as shown below. If MAX, MIN, or AVE is not displayed, an instantaneous value is assumed.

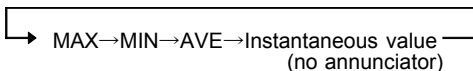

- Data (MAX, MIN, AVE) remains displayed while the display is switched. If maximum or minimum data is updated in the meantime, however, the data values will change.
- With the recording function activated, the auto power-off function remains disabled. (APS off.)
- The average value (AVE) displayed is calculated by:  

$$\text{Average Value} = [(\text{Maximum value} + \text{Minimum Value})/2].$$

- If the recording function is activated and Instantaneous value (no annunciator) selected after you activate PEAK mode with the **SLOW/PEAK/Hz** button, you can see the fluctuation of the peak.

## 2. Display of Elapsed Time

- When you press the **MAX/MIN** button to activate the recording function, the bar graph segments flash and the elapsed time appears.
- When "min" is shown in the right-hand corner of the bar graph, each segment of the bar graph corresponds to one minute.

Every time one minute elapses, one segment of the flashing bar graph goes on. When all segments on the bar graph go on, the elapsed time is 30 minutes. When the elapsed time exceeds 30 minutes, one segment of the flashing bar graph goes off every time one minute elapses.

When the segments left of a flashing segment remain on: the number of "on" segments represents the elapsed time (0 ~ 29).

The illustration below shows when 20 minutes have elapsed:

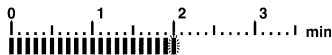



When the segments right of a flashing segment remain on: the number of "off" segments (+30) represents the elapsed time (30 ~ 59).

The illustration below shows when 50 minutes have elapsed:

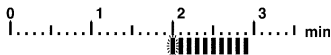

- When digital display switches the average value (AVE) to a instantaneous value when you press the **MAX/MIN** button, the right corner of the bar graph indicates hours. In this mode, each segment of the bar graph corresponds to one hour. The way to read the bar graph here is similar to reading it in minutes. When all bar graph segments remain on, the elapsed time is 29 hours.

The illustration below shows when one hour, 40 minutes have elapsed.



### 3. Deactivation of Recording Function

- Pressing the **HOLD** button deactivates the recording function. **HOLD** goes on, **REC** stops flashing and goes on, and the elapsed time stops incrementing.
- While the recording function is being deactivated, data is not updated, even if the clamp sensor is disconnected from the conductor.
- Pressing the **HOLD** button again cancels **HOLD** display and activates the recording function again, with **REC** flashing again.

#### 4. Resetting of Recording Function

Push **OADJ/RESET** button, in the case that data is reset during the recording function action.

#### 5. Cancellation of Recording Function

To cancel the recording function, press the related function button (**⌘A** or **⌘V**) for the measurement in progress. Once the recording function is canceled, the auto power-off function becomes effective. (**APS** goes on.)

#### NOTE

- For a long term measurement, check how much the battery power remains. (Shown on the bar graph at power on.)
- When starting the recording function (**REC**) in an auto range, the range is set as the range of when that pushed **MAX/MIN** button.
- When you need minimum value and average value data, make sure to activate the recording function during measurement. If the function is activated when there is no input, the minimum value will remain zero. To deactivate the recording function, press the **HOLD** button and read minimum value and average value to terminate measurement. If you disconnect the clamp or test lead from the circuit under measurement without deactivating the recording function beforehand, the minimum value will be zero.
- When the instrument is turned off, accumulated data are lost.

---

---

### 3.5 Automatically Turning Power Off (Auto Power-Off Function **APS**)

- When the **APS** annunciator is displayed, the auto power-off function is active.
  - If no button is pressed for about 10 minutes, the instrument turns itself off automatically.
  - Immediately before turning off automatically, **APS** annunciator blinks and a beep tone is heard for about 30 seconds.
  - By pressing any button except **POWER** button, you will extend the powered state for another 10 minutes.
- Procedure for disabling the auto power-off function.
- Press **POWER** button with holding down **HOLD** button, when you turn power on.
  - Use the recording function (**REC**) by pressing **MAX/MIN** button.

## 3.6 Beep Tone

- To disable the beep tone

To disable the beep tone, hold **RANGE** button when turning the instrument on by pressing **POWER** button.

Warning sounds and the continuity beep cannot be disabled.

- To enable the beep tone

The beep is re-enabled the next time you press the **POWER** button to turn the meter on.

# Chapter 4

## Specifications

### 4.1 Measurement Specifications

Temperature and humidity for guaranteed accuracy	23°C±5°C (73°F±9°F), 80% RH or less (no condensation)
Guaranteed accuracy period	1 year, or opening and closing of the Clamp Sensor 10,000 times, whichever comes first

#### 4.1.1 Current Measurement Specifications

##### Current display accuracy

##### 1. DC current A (mean value)

Range (Accuracy Range)	Resolution	DC
200 A (10.0 to 200.0 A)	0.1 A	±1.3%rdg.±3dgt.
2000 A (100 to 2000 A)	1 A	±1.3%rdg.±3dgt.

##### 2. AC current Arms (true rms)

Range (Accuracy Range)	Resolution	45 to 66Hz	10 to 45, 66 to 1kHz
200 A (10.0 to 200.0 A)	0.1 A	±1.3%rdg.±3dgt.	±2.0%rdg.±5dgt.
2000 A (100 to 1800 A) (1800 to 2000 A)	1 A	±1.3%rdg.±3dgt.	±2.0%rdg.±5dgt.
		±2.3%rdg.±3dgt.	

Measurement response (during a f.s. input):

Rise response time (0% to 90%) 250 ms or less

Fall response time (100% to 10%) 500 ms or less

## 3. AC+DC current Arms (true rms)

Range (Accuracy Range)	Resolution	DC, 45 to 66Hz	10 to 45, 66 to 1kHz
200 A (10.0 to 200.0 A)	0.1 A	$\pm 1.3\% \text{rdg.} \pm 13 \text{dgt.}$	$\pm 2.0\% \text{rdg.} \pm 7 \text{dgt.}$
2000 A (100 to 1800 A) (1800 to 2000 A)	1 A	$\pm 1.3\% \text{rdg.} \pm 13 \text{dgt.}$	$\pm 2.0\% \text{rdg.} \pm 7 \text{dgt.}$
		$\pm 2.3\% \text{rdg.} \pm 13 \text{dgt.}$	

Measurement response (during a f.s. input):

Rise response time (0% to 90%) 250 ms or less

Fall response time (100% to 10%) 500 ms or less

 Peak measurement accuracy (Peak hold function)

During continuous input of sine waves

## 1. DC current A peak (wave peak value)

Range (Accuracy Range)	Resolution	DC
200 A (10 to 500 A)	1 A	$\pm 1.3\% \text{rdg.} \pm 7 \text{dgt.}$
2000 A (100 to 2300 A) (2300 to 2840 A)		$\pm 1.3\% \text{rdg.} \pm 7 \text{dgt.}$
		$\pm 6.0\% \text{rdg.} \pm 7 \text{dgt.}$

## 2. AC current A peak (wave peak value)

Range (Accuracy Range)	Resolution	45 to 66Hz	10 to 45, 66 to 1kHz
200 A (10 to 500 A)	1 A	$\pm 1.3\% \text{rdg.} \pm 7 \text{dgt.}$	$\pm 2.0\% \text{rdg.} \pm 7 \text{dgt.}$
2000 A (100 to 2300 A) (2300 to 2840 A)		$\pm 1.3\% \text{rdg.} \pm 7 \text{dgt.}$	$\pm 2.0\% \text{rdg.} \pm 7 \text{dgt.}$
		$\pm 6.0\% \text{rdg.} \pm 7 \text{dgt.}$	

## 3. AC+DC current A peak (wave peak value)

Range (Accuracy Range)	Resolution	DC, 45 to 66Hz	10 to 45, 66 to 1kHz
200 A (10 to 500 A)	1 A	$\pm 1.3\% \text{rdg.} \pm 7 \text{dgt.}$	$\pm 2.0\% \text{rdg.} \pm 7 \text{dgt.}$
2000 A (100 to 2300 A) (2300 to 2840 A)		$\pm 1.3\% \text{rdg.} \pm 7 \text{dgt.}$	$\pm 2.0\% \text{rdg.} \pm 7 \text{dgt.}$
		$\pm 6.0\% \text{rdg.} \pm 7 \text{dgt.}$	

Frequency measurement Hz

Display accuracy

Range (Accuracy Range)	Resolution	
10 Hz (1.00 to 10.00 Hz)	0.01 Hz	$\pm 0.3\% \text{rdg.} \pm 1 \text{dgt.}$
100 Hz (10.0 to 100.0 Hz)	0.1 Hz	$\pm 0.3\% \text{rdg.} \pm 1 \text{dgt.}$
1000 Hz (100 to 1000 Hz)	1 Hz	$\pm 1.0\% \text{rdg.} \pm 1 \text{dgt.}$

---

### Current Specifications

---

Maximum input current            2000 Arms continuous, 2840 Amax.  
See Fig.3

---

Effect of conductor position        within  $\pm 0.7\%$  (in any direction from  
sensor center)

---

External magnetic field interference    AC 400 A/m (external magnetic fields)  
corresponds to 2 A or less (display)

---

Maximum rated voltage to earth        max. 600 Vrms

---

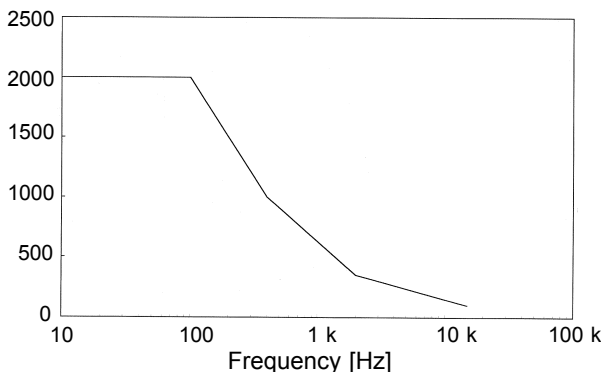

Fig.3 Frequency-dependent deletion characteristics

## 4.1.2 Voltage Measurement Specifications

### Voltage display accuracy

#### 1. DC voltage V (mean value)

Range (Accuracy Range)	Resolution	DC
30 V (3.00 to 30.00 V)	0.01 V	$\pm 1.0\% \text{rdg.} \pm 3 \text{dgt.}$
300 V (30.0 to 300.0 V)	0.1 V	$\pm 1.0\% \text{rdg.} \pm 3 \text{dgt.}$
600 V (60.0 to 600V)	1 V	$\pm 1.0\% \text{rdg.} \pm 3 \text{dgt.}$

#### 2. AC voltage Vrms (true rms)

Range (Accuracy Range)	Resolution	45 to 66Hz	10 to 45, 66 to 1kHz
30V (3.00~30.00V)	0.01V	$\pm 1.0\% \text{rdg.} \pm 3 \text{dgt.}$	$\pm 1.5\% \text{rdg.} \pm 5 \text{dgt.}$
300V (30.0~300.0V)	0.1V	$\pm 1.0\% \text{rdg.} \pm 3 \text{dgt.}$	$\pm 1.5\% \text{rdg.} \pm 5 \text{dgt.}$
600V (60.0~600V)	1V	$\pm 1.0\% \text{rdg.} \pm 3 \text{dgt.}$	$\pm 1.5\% \text{rdg.} \pm 5 \text{dgt.}$

#### 3. AC+DC voltage Vrms (true rms)

Range (Accuracy Range)	Resolution	DC, 45 to 66Hz	10 to 45, 66 to 1kHz
30 V (3.00 to 30.00 V)	0.01 V	$\pm 1.0\% \text{rdg.} \pm 13 \text{dgt.}$	$\pm 1.5\% \text{rdg.} \pm 13 \text{dgt.}$
300 V (30.0 to 300.0 V)	0.1 V	$\pm 1.0\% \text{rdg.} \pm 7 \text{dgt.}$	$\pm 1.5\% \text{rdg.} \pm 7 \text{dgt.}$
600 V (60.0 to 600 V)	1 V	$\pm 1.0\% \text{rdg.} \pm 7 \text{dgt.}$	$\pm 1.5\% \text{rdg.} \pm 7 \text{dgt.}$

### Peak measurement accuracy (Peak hold function)

During continuous input of sine waves

#### 1. DC voltage V peak (wave peak value)

Range (Accuracy Range)	Resolution	DC
30 V (3.0 to 75.0 V)	0.1 V	$\pm 1.0\% \text{rdg.} \pm 7 \text{dgt.}$
300 V (30 to 750 V)	1 V	$\pm 1.0\% \text{rdg.} \pm 7 \text{dgt.}$
600 V (60 to 1000 V)		$\pm 1.0\% \text{rdg.} \pm 7 \text{dgt.}$



## 2. AC voltage V peak (wave peak value)

Range (Accuracy Range)	Resolution	45 to 66Hz	10 to 45, 66 to 1kHz
30 V (3.0 to 75.0 V)	0.1 V	$\pm 1.0\% \text{rdg.} \pm 7 \text{dgt.}$	$\pm 1.5\% \text{rdg.} \pm 7 \text{dgt.}$
300 V (30 to 750 V)	1 V	$\pm 1.0\% \text{rdg.} \pm 7 \text{dgt.}$	$\pm 1.5\% \text{rdg.} \pm 7 \text{dgt.}$
600 V (60 to 700 V)		$\pm 1.0\% \text{rdg.} \pm 7 \text{dgt.}$	$\pm 1.5\% \text{rdg.} \pm 7 \text{dgt.}$
600 V (700 to 1000 V)		$\pm 2.0\% \text{rdg.} \pm 20 \text{dgt.}$	$\pm 2.5\% \text{rdg.} \pm 20 \text{dgt.}$

## 3. AC+DC voltage V peak (wave peak value)

Range (Accuracy Range)	Resolution	DC,45 to 66Hz	10 to 45, 66 to 1kHz
30 V (3.0 to 75.0 V)	0.1 V	$\pm 1.0\% \text{rdg.} \pm 7 \text{dgt.}$	$\pm 1.5\% \text{rdg.} \pm 7 \text{dgt.}$
300 V (30 to 750 V)	1 V	$\pm 1.0\% \text{rdg.} \pm 7 \text{dgt.}$	$\pm 1.5\% \text{rdg.} \pm 7 \text{dgt.}$
600 V (60 to 700 V)		$\pm 1.0\% \text{rdg.} \pm 7 \text{dgt.}$	$\pm 1.5\% \text{rdg.} \pm 7 \text{dgt.}$
600 V (700 to 1000 V)		$\pm 2.0\% \text{rdg.} \pm 20 \text{dgt.}$	$\pm 2.5\% \text{rdg.} \pm 20 \text{dgt.}$

Frequency measurement Hz

Display accuracy

Range (Accuracy Range)	Resolution	
10Hz (1.00 to 10.00 Hz)	0.01 Hz	$\pm 0.3\% \text{rdg.} \pm 1 \text{dgt.}$
100Hz (10.0 to 100.0 Hz)	0.1 Hz	$\pm 0.3\% \text{rdg.} \pm 1 \text{dgt.}$
1000Hz (100 to 1000 Hz)	1 Hz	$\pm 1.0\% \text{rdg.} \pm 1 \text{dgt.}$

---

### Voltage Specifications

---

Maximum input voltage                      1000 V max.

---

### 4.1.3 Resistance Measurement Specifications

Range (Accuracy Range)	Resolution	Accuracy	Overload protection	Open terminal voltage
1 k $\Omega$ (10 to 999 $\Omega$ )	1 $\Omega$	$\pm(1.5\%rdg.+5dgt.)$	600 Vrms	3.1 VDC or less
10 k $\Omega$ (0.95 k $\sim$ 10.00 k $\Omega$ )	0.01 k $\Omega$			

### 4.1.4 Continuity Check

Range	Resolution	Threshold level	Overload protection	Open terminal voltage
1 k $\Omega$	1 $\Omega$	30 $\Omega \pm 5 \Omega$ or less	600 Vrms	3.1 VDC or less

## 4.2 General Specifications

### □ Accessory Functions:

Auto-zero adjustment function Pressing **0ADJ/RESET** button once in DCA, AC+DCA, or DCV mode.

Zero cancel function Pressing **0ADJ/RESET** button once with holding **HOLD** button in AC or AC+DC mode.

Recording Maximum (MAX), minimum (MIN), average (AVE) value display selectable for current, voltage and frequency measurements

Data hold Data hold function

Auto power-off Automatic shutdown after  $10.5 \pm 1$  minutes. Beep tone warning before the shutdown. Extending and disabling possible.

Beep tone ON/OFF

### □ Display

Digital counter 2500 counts max. (current)  
3750 counts max. (voltage)  
1250 counts max. (frequency)  
1000 counts max. (Resistance)

Bar graph display 35 segments

Over-range display "O.L." ► (bar graph)

Battery low warning **B**

Data hold annunciator **HOLD**

Auto power-off annunciator **APS**

Units	A, V, Hz, $\Omega$
Zero suppression	5 counts
Display update rate	Digital counter NORMAL approx. 2 times/second SLOW approx. 1 time/3 seconds FAST approx. 4 times/second
Bar graph	approx. 4 times/second
Display response time (the range is fixed, 0% to 100%)	Current, Voltage: 1 s max. Frequency: 1 s max. (1000 Hz, 100 Hz range) 2.5 s max. (10 Hz range) Resistance, Continuity check: 1.1 s max.
Range switching	Auto range, manual (fixed) range (selectable). (except for resistance, continuity check)
Circuit dynamic characteristics (crest factor)	2.5 max. (1.42 for 2000 A range, 1.7 for 600 V range)
Withstand voltage	Clamp sensor - Chassis, clamp sensor - circuit: 5.312 kV AC for 15 seconds
Location for use	Indoor, altitude up to 2000 m
Applicable standards	Safety: EN61010-1:2001 EN61010-2-032:2002 Type A current sensor Pollution level 2, measurement category III (expected transient overvoltage: 6000 V) EN61010-031:2002 EN60529:1991 IP40 (protected against access to hazardous parts with a wire) EMC: EN61326:1997+A1:1998+A2:2001 +A3:2003

Maximum conductor diameter for measurement	φ55 mm max.
Operating temperature and humidity range	0 to 40°C (32 to 104°F), 80%RH or less (no condensation)
Temperature characteristics	In 0 to 40°C range: 0.1×accuracy specifications/°C
Storage temperature range	-10 to 50°C (14 to 122°F, no condensation)
Power source	One 6F22 (006P) 9 V battery
Maximum power consumption	110 mVA
Battery life	Approx. 20 hours (continuous, no load)
External dimensions	Approx. 62W×260H×39D mm Approx. 2.44"W×10.24"H×1.54"D
Mass	Approx. 540 g Approx. 19.0 oz.
Accessories	9207-10 TEST LEAD (red and black) 1 9345 CARRYING CASE 1 Hand Strap 1 Battery 6F22(006P) 1 Instruction manual 1

---

## Chapter 5 Maintenance and Service

---

---

---

### 5.1 Cleaning

- To clean the instrument, wipe it gently with a soft cloth moistened with water or mild detergent. Never use solvents such as benzene, alcohol, acetone, ether, ketones, thinners or gasoline, as they can deform and discolor the case.
- Measurements are degraded by dirt on the mating surfaces of the clamp-on sensor, so keep the surfaces clean by gently wiping with a soft cloth.
- To avoid corrosion from battery leakage, remove the batteries from the instrument if it is to be stored for a long time.

---

---



### 5.2 After service

- The minimum stocking period for replacement parts is five years after end of production.
- If damage is suspected, check the "5.3 Troubleshooting" section before contacting your dealer or Hioki representative.
- When sending the instrument for repair, remove the batteries and pack carefully to prevent damage in transit. Include cushioning material so the instrument cannot move within the package. Be sure to include details of the problem. Hioki cannot be responsible for damage that occurs during shipment.

## 5.3 Troubleshooting

 Before returning for repair

If the instrument seems not to be working normally, check the following points first before requesting service.

Symptom / Remedy	Battery	Battery clip	Test leads
	Replace battery. (See 2.1: Preparations)	Check connection of battery to clip.	Check test leads for broken wire.
Instrument does not come on.	Yes	Yes	
 indication appears and instrument immediately turns off.	Yes		
 indication appears.	Yes		
Instrument turns off during use.*	Yes	Yes	
Voltage and resistance cannot be measured.			Yes
If problem persists, request service.			

**NOTE**

\* When APS (auto power-off) is effective, the instrument is automatically shut down when no button is pressed for about 10 minutes. (See 3.5: Automatically Turning Power Off (Auto Power-Off Function **APS** ))

Other symptoms that may occur are as follows.

**If no power is supplied:**

Check that it has sufficient remaining power. (See 2.1.4: Battery Low Warning (When **B** mark lights) )

**The counter doesn't become zero:**

In DCA, AC+DCA, or DCV mode

Use the auto-zero adjustment function (See 3.1.1).

(If this occurs in AC+DCA mode after performing the auto-zero-adjustment, perform the zero cancel correction function.)

In ACA, ACV, or AC+DCV mode

Use the zero-cancel correction function (See 3.1.2).

Resistance measurement or continuity check

If 0  $\Omega$  is displayed when the red and black test leads are unconnected (open-circuit), internal circuitry may be damaged, requiring repair service.

**The measured value is larger than the estimated value.**

Current / Voltage / Frequency measurement:

- Check that you're using the proper range.
- Examine the waveform to confirm that no components but the estimated frequency are being used.
- Check that the counter has been reset with **OADJ/RESET** button before peak measurement.
- Look for magnetic fields, electrical fields or possible noise sources near the instrument.
- Check the waveform. Some special frequencies can't be measured, such as those of inverters. (At frequency measurement)



**❑ The measured value is smaller than the estimated value.**

Current / Voltage measurement:

- Check that the clamp sensor is firmly closed. (At current measurement)
- Check that the test leads are fully connected. (At voltage measurement)
- Check that the frequency of the measured circuit is within the range provided in the specifications. (A smaller value will be displayed for a high inverter carrier frequency.) \*Items within parentheses apply to current measurement only
- Check that the proper steps have been taken, according to procedure described in 3.1.1: Auto-zero adjustment function and 3.1.2: Zero-cancel correction function.
- Check that you're using the proper mode. (See 1.5: Modes.)
- Check that the peak value is below the circuit dynamic value provided in the specifications. (To check transitional peak values, see Notes in 2.2.4 and 2.3.4: Peak Hold Measurement.)
- Check that the crest factor (peak value / RMS value) is below the circuit dynamic value provided in the specifications.
- Check that the battery warning annunciator is off.

Frequency measurement:

- Check the waveform. Some special frequencies can't be measured, such as those of inverters.
- Check that the input value corresponds to 10% or more of the range.

**❑ The measured value fluctuates.**

- Check that the measured circuit is stable.
- During voltage measurements, check that the test leads are fully connected.
- Check the waveform. Some special frequencies can't be measured, such as those of inverters.

**❑ The displayed value is out of range O.L.****Resistance measurement or continuity check**

If **O.L.** is displayed when the test leads are shorted together, a test lead may be broken or internal circuitry may be damaged.

Check for broken test leads by taking a voltage measurement. If a test lead is broken, replace with Model 9207-10 TEST LEAD.

**Current measurement**

o If nothing can be measured (no input detected) the sensor element or internal circuitry may be damaged, requiring repair service. If the damage is to internal circuitry, the displayed value may appear over range **O.L.** during voltage measurement.

**Voltage measurement**

If over range is indicated when nothing is being measured, internal circuitry may be damaged.

---

---

## 5.4 Error Message

Repair is required if E.001 to E.004 is indicated on the counter, when power is turned on.

<b>Error No.</b>	<b>Symptom</b>	<b>Remedy</b>
E001	Checksum error in single-chip microcontroller internal ROM	Component replacement required. Please contact your dealer or HIOKI representative.
E002	Checksum error in single-chip microcontroller internal RAMR/W	
E003	Checksum error in EEPROM	
E004	EEPROM data error	

**HIOKI**

**DECLARATION OF CONFORMITY**

Manufacturer's Name: HIOKI E.E. CORPORATION  
Manufacturer's Address: 81 Koizumi, Ueda, Nagano 386-1192, Japan  
Product Name: CLAMP ON AC/DC HITESTER  
Model Number: 3285-20  
Accessory: 9207-10 TEST LEAD

The above mentioned products conform to the following product specifications:

Safety: EN61010-1:2001  
EN61010-031:2002  
EN61010-2-032:2002

EMC: EN61326:1997+A1:1998+A2:2001+A3:2003  
Class B equipment  
Portable test, measuring and monitoring  
equipment used in low-voltage distribution  
systems

Supplementary Information:

The products herewith comply with the requirements of the Low Voltage Directive 73/23/EEC and the EMC Directive 89/336/EEC.

20 September 2006

HIOKI E.E. CORPORATION

  
\_\_\_\_\_  
Tatsuyoshi Yoshiike  
President

3285B999-01

HIOKI 3285-20 CLAMP ON AC/DC HiTESTER  
Instruction Manual

Publication date: September 2006 Revised edition 4  
Edited and published by HIOKI E.E. CORPORATION  
Technical Support Section

All inquiries to International Sales and Marketing Department

81 Koizumi, Ueda, Nagano, 386-1192, Japan

TEL: +81-268-28-0562 / FAX: +81-268-28-0568

E-mail: [os-com@hioki.co.jp](mailto:os-com@hioki.co.jp)

URL <http://www.hioki.co.jp/>

Printed in Japan 3285B981-04

- 
- 
- All reasonable care has been taken in the production of this manual, but if you find any points which are unclear or in error, please contact your supplier or the International Sales and Marketing Department at HIOKI headquarters.
  - In the interests of product development, the contents of this manual are subject to revision without prior notice.
  - Unauthorized reproduction or copying of this manual is prohibited.
- 
-

# HIOKI

---

HIOKI E. E. CORPORATION

## HEAD OFFICE

81 Koizumi, Ueda, Nagano 386-1192, Japan  
TEL +81-268-28-0562 / FAX +81-268-28-0568  
E-mail: [os-com@hioki.co.jp](mailto:os-com@hioki.co.jp)  
URL <http://www.hioki.co.jp/>

## HIOKI USA CORPORATION

6 Corporate Drive, Cranbury, NJ 08512, USA  
TEL +1-609-409-9109 / FAX +1-609-409-9108

---

3285B981-04 06-09H



Printed on recycled paper

---