

INSTRUCTION MANUAL

3560

AC mΩ HiTESTER

HIOKI E. E. CORPORATION

Contents

Introduction	i
Inspection	i
Safety Notes	ii
Notes on Use	iv
Chapter Summary	v
Chapter 1 Overview	1
1.1 Product Overview	1
1.2 Features	2
1.3 Identification of Controls and Indicators	3
1.3.1 Fluorescent Character Display Tube	3
1.3.2 Front Panel	4
1.3.3 Rear Panel / Side Panel	6
Chapter 2 Specifications	7
2.1 General Specifications	7
2.2 Measurement Range	9
2.3 External Dimensions	10
Chapter 3 Preparing for Measurement	11
3.1 Mounting the Interface	11
3.2 Connecting the Power Cord	12
3.3 Connecting the Measurement Leads	13
3.4 Powering On/Off	14
3.5 Setting the Power Supply Frequency	15
3.6 Instrument Handle	16
Chapter 4 Measurement Procedure	17
4.1 Selecting the Measurement Mode	18
4.2 Setting the Measurement Range	19
4.3 Advanced Setting	20
4.3.1 Sampling Rate	20
4.3.2 Buzzer	20
4.3.3 Hold	21
4.3.4 Lead Line Break Check (Imperfect Contact Check)	23

4.3.5	Voltage Limiter	24
4.3.6	Zero Clear	24
4.3.7	Key Lock	25
4.3.8	Local	25
4.4	Zero Adjust	26
4.5	Starting Measurement	28
Chapter 5	Comparator Function	31
5.1	Resistance Measurement Mode	32
5.2	Resistance and Voltage Measurement Mode	34
5.3	Selecting the AUTO/MANU Comparator Mode	36
5.4	Changing the Comparator Number	37
5.5	Switching On/Off the Comparator	38
5.6	Checking the Comparator Conditions (View)	39
5.6.1	View in Comparator of Resistance Measurement Mode Setting	39
5.6.2	View in Comparator of Resistance and Voltage Measurement Mode Setting	40
Chapter 6	External Control Terminal and External Output Terminal	41
6.1	Terminals and Signals	42
6.2	Connection Method	44
6.3	Measurement by External Control Terminal and External Output Terminal	45
6.3.1	External Control Terminal (Input Signal)	45
6.3.2	External Output Terminal (Output Signal)	46
6.3.3	Timing Chart	47
6.3.4	Internal Circuit Configuration (Input/Output)	51
Chapter 7	RS-232C Interface	53
7.1	Connection to Computer (RS-232C)	54
7.2	Operating Procedure (RS-232C)	55
7.2.1	Setting the RS-232C	55
7.2.2	Communication Methods by the RS-232C	55
7.2.3	Program Messages	56
7.2.4	Message Format	56
7.2.5	Headers	57
7.2.6	Data Formats	58
7.2.7	Delimiters	58

7.2.8	Separators	59
7.2.9	Abbreviation of Compound Commands	59
7.2.10	Output Buffer	60
7.2.11	Input Buffer	60
7.2.12	Status Byte Registers	60
7.2.13	Event Registers	61
7.3	Message Code Table	63
7.3.1	Common Command	63
7.3.2	Messages	64
7.4	Message Reference	66
7.4.1	Common Command Messages	67
7.4.2	Specific Command Messages	72
7.5	Initialize Item List	92
7.6	Notes on RS-232C Interface	93

Chapter 8 GP-IB Interface (Option) 95

8.1	Connection to Computer (GP-IB)	96
8.2	Operating Procedure (GP-IB)	97
8.2.1	Communication Methods by the GP-IB	97
8.2.2	Program Messages	97
8.2.3	Message Format	98
8.2.4	Headers	99
8.2.5	Data Formats	100
8.2.6	Delimiters	101
8.2.7	Separators	101
8.2.8	Abbreviation of Compound Commands	102
8.2.9	Output Queue	102
8.2.10	Input Buffer	102
8.2.11	Status Model	103
8.2.12	Status Byte Registers	104
8.2.13	Event Registers	105
8.2.14	GP-IB Command	107
8.3	Sample Program	108
8.4	Notes of the GP-IB	111

Chapter 9 Printer Interface (Option) 113

9.1	Outline	113
9.2	Connection with a General-purpose Centronics Printer	114
9.3	Printing	115

Chapter 10 Useful Information and Advanced Measurement	117
10.1 AC Four-terminal Method	117
10.2 Synchronous Detection System	118
10.3 Configuration and Extension of the Measurement Leads	119
10.4 Effect of Over-voltage	121
10.5 SOURCE/SENSE Line Break Check	122
10.6 IEC 512-2, JIS C 5402 and JIS C 5441	123
10.7 Example of Advanced Measurements	124
10.8 Calibration of the 3560	125
Chapter 11 Maintenance and Service	127
11.1 Message Code Table	127
11.2 Cleaning	128
11.3 Troubleshooting	129
11.4 Options	130
11.4.1 9588 GP-IB INTERFACE	130
11.4.2 9589 PRINTER INTERFACE	130
11.4.3 9203 DIGITAL PRINTER	130
11.4.4 9287-10 CLIP TYPE LEAD (Option)	131
11.4.5 9452 CLIP TYPE LEAD	131
11.4.6 9453 FOUR TERMINAL LEAD	132
11.4.7 9455 PIN TYPE LEAD	132
11.4.8 9461 PIN TYPE LEAD	133
11.4.9 9467 LARGE CLIP TYPE LEAD	133
11.4.10 9454 ZERO ADJUSTMENT BOARD	133
11.4.11 9466 REMOTE CONTROL SWITCH	134

Introduction

Thank you for purchasing the HIOKI "3560 AC m HiTESTER" To obtain maximum performance from the instrument, please read this manual first, and keep it handy for future reference.

Inspection

When you receive the instrument, inspect it carefully to ensure that no damage occurred during shipping. In particular, check the accessories, panel switches, and connectors. If damage is evident, or if it fails to operate according to the specifications, contact your dealer or Hioki representative.

Accessories

9287-10 CLIP TYPE LEAD	1
Three-core power cord (L type)	1
Instruction manual	1
Basic instructions	1

Options

9455	PIN TYPE LEAD
9461	PIN TYPE LEAD
9465	PIN TYPE LEAD
9467	LARGE CLIP TYPE LEAD
9452	CLIP TYPE LEAD
9453	FOUR TERMINAL LEAD
9466	REMOTE CONTROL SWITCH
9454	ZERO ADJUSTMENT BOARD
9588	GP-IB INTERFACE
9151-02	GP-IB CONNECTOR CABLE (2 m)
9151-04	GP-IB CONNECTOR CABLE (4 m)
9589	PRINTER INTERFACE
9203	DIGITAL PRINTER
9425	CONNECTION CABLE (2-meter long for connecting to the 9425)
9233	RECORDING PAPER (Ten 10-meter rolls for the 9233)









Safety Notes

WARNING



This instrument is designed to comply with IEC 61010 Safety Standards, and has been thoroughly tested for safety prior to shipment. However, mishandling during use could result in injury or death, as well as damage to the instrument. Be certain that you understand the instructions and precautions in the manual before use. We disclaim any responsibility for accidents or injuries not resulting directly from instrument defects.

This manual contains information and warnings essential for safe operation of the instrument and for maintaining it in safe operating condition. Before using the instrument, be sure to carefully read the following safety notes.

Safety symbols

	<ul style="list-style-type: none"> • The  symbol printed on the instrument indicates that the user should refer to a corresponding topic in the manual (marked with the  symbol) before using the relevant function. • In the manual, the  symbol indicates particularly important information that the user should read before using the instrument.
	Indicates AC (Alternating Current).
	Indicates DC (Direct Current).
	Indicates the ON side of the power switch.
	Indicates the OFF side of the power switch.

The following symbols in this manual indicate the relative importance of cautions and warnings.

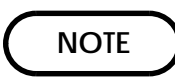
	Indicates that incorrect operation presents an extreme hazard that could result in serious injury or death to the user.
	Indicates that incorrect operation presents a significant hazard that could result in serious injury or death to the user.
	Indicates that incorrect operation presents a possibility of injury to the user or damage to the instrument.
	Indicates advisory items related to performance or correct operation of the instrument.

Measurement categories (Overvoltage categories)

To ensure safe operation of measurement instruments, IEC 61010 establishes safety standards for various electrical environments, categorized as CAT I to CAT IV, and called measurement categories. These are defined as follows.

CAT I : Secondary electrical circuits connected to an AC electrical outlet through a transformer or similar device.

CAT II : Primary electrical circuits in equipment connected to an AC electrical outlet by a power cord (portable tools, household appliances, etc.)

CAT III: Primary electrical circuits of heavy equipment (fixed installations) connected directly to the distribution panel, and feeders from the distribution panel to outlets.

CAT IV : The circuit from the service drop to the service entrance, and to the power meter and primary overcurrent protection device (distribution panel).

Higher-numbered categories correspond to electrical environments with greater momentary energy. So a measurement device designed for CAT III environments can endure greater momentary energy than a device designed for CAT II.

Using a measurement instrument in an environment designated with a higher-numbered category than that for which the instrument is rated could result in a severe accident, and must be carefully avoided.

Never use a CAT I measuring instrument in CAT II, III, or IV environments.

The measurement categories comply with the Overvoltage Categories of the IEC60664 Standards.

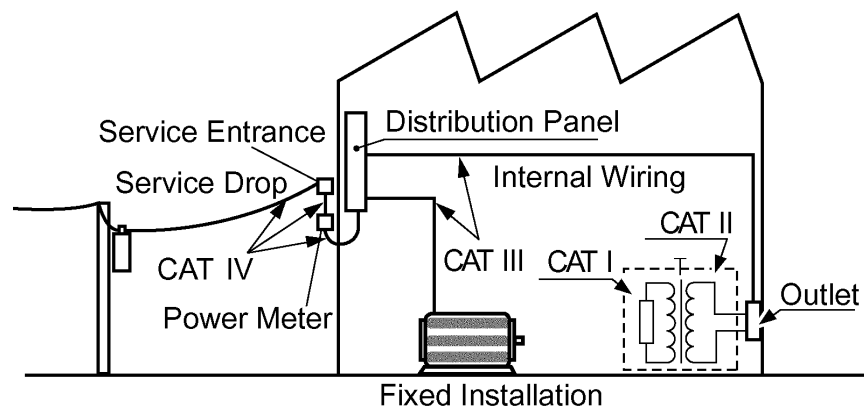

We define measurement tolerances in terms of f.s. (full scale), rdg. (reading) and dgt. (digit) values, with the following meanings:

f.s. (maximum display value or scale length)

The maximum displayable value or the full length of the scale.

This is usually the maximum value of the currently selected range.

rdg. (reading or displayed value)

The value currently being measured and indicated on the measuring instrument.

dgt. (resolution)

The smallest displayable unit on a digital measuring instrument, i.e., the input value that causes the digital display to show a "1".

Notes on Use



Follow these precautions to ensure safe operation and to obtain the full benefits of the various functions.

Preliminary Checks

- Before using the instrument the first time, verify that it operates normally to ensure that no damage occurred during storage or shipping. If you find any damage, contact your dealer or Hioki representative.
- Before using the instrument, make sure that the insulation on the measurement leads is undamaged and that no bare conductors are improperly exposed. Using the instrument in such conditions could cause an electric shock, so contact your dealer or Hioki representative for replacements.

DANGER

Be sure to ensure the floating state for a battery circuit (measured object) with voltage exceeding 30 Vrms, 42.4 Vpeak, or 60 VDC. Connecting the instrument to a circuit exceeding 30 Vrms, 42.4 Vpeak, or 60 VDC may lead to electric shock.

WARNING

- **Connect SOURCE and SENSE (banana plug) in the proper manner. For the correct procedure, refer to Section 3.3 "Connecting the Measurement Leads ".**
- **To avoid injury or damage to the instrument, do not attempt to measure AC voltage, or DC voltage exceeding 60 V.**
- **Do not allow the instrument to get wet, and do not take measurements with wet hands. This may cause an electric shock.**
- **Do not use the instrument where it may be exposed to corrosive or combustible gases. The instrument may be damaged or cause an explosion.**
- **To avoid electric shock when measuring live lines, wear appropriate protective gear, such as insulated rubber gloves, boots and a safety helmet.**

CAUTION

- Do not store or use the instrument where it could be exposed to direct sunlight, high temperature or humidity, or condensation. Under such conditions, the instrument may be damaged and insulation may deteriorate so that it no longer meets specifications.
- This instrument is designed for use indoors. It can be operated at temperatures between 0 and 40 °C without degrading safety.
- Do not input voltage and current between SOURCE-Hi and SENSE-Hi or between SOURCE-Lo and SENSE-Lo.
- Various connectors are provided on the outer panel of the instrument. Make sure the instrument is turned off before connecting cables to these connectors. To prevent short-circuits, make sure connections are made correctly.
- The GND terminals on the external control terminal, external output terminal, RS-232C interface, GP-IB interface, and printer interface are grounded. This means that the devices connected to the GND terminals are grounded. Take care in handling them.

Chapter Summary

This manual consists of the following chapters.

"Introduction", "Inspection", "Safety Notes", "Notes on Use" include some important notes which you should read before using the instrument.

- | | |
|-------------------|---|
| Chapter 1 | Overview
Outlines the instrument, and describes the nomenclatures and functions of the components. |
| Chapter 2 | Specifications
Describes general specifications and measurement ranges. |
| Chapter 3 | Preparing for Measurement
Describes how to turn on the power, connect the measurement leads, and set the power-supply frequency. |
| Chapter 4 | Measurement Procedure
Describes basic measurement procedures. |
| Chapter 5 | Comparator Function
Describes the setup and functions of the comparator. |
| Chapter 6 | External Control Terminal and External Output Terminal
Describes external control via the external-control terminal and external-output terminal. |
| Chapter 7 | RS-232C Interface
Describes external control via RS-232C. |
| Chapter 8 | GP-IB Interface (Option)
Describes external control via GP-IB. |
| Chapter 9 | Printer Interface (Option)
Describes Printer Interface. |
| Chapter 10 | Useful Information and Advanced Measurement
Provides information on the advanced applications of the 3560 instrument. |
| Chapter 11 | Maintenance and Service
Describes service operations and optional equipment of the 3560 instrument. |

Chapter 1

Overview

1.1 Product Overview

The 3560 AC m HiTESTER is a contact-resistance meter capable of providing quick and accurate measurements for the contact resistance of elements such as relays, switches, and connectors, as well as the internal resistance and open-circuit voltage of batteries.

This instrument is provided with a comparator function, external output terminal, external control terminal, and RS-232C interface as standard features. For even higher performance, optional GP-IB and printer interfaces are available as options.

1.2 Features

(1) AC four-terminal method for accurate measurement of resistance

Thanks to the AC four-terminal method, the 3560 is capable of accurate resistance measurements unaffected by the resistance of leads or by contact resistance generated between the lead and the measured object.

(2) Measurement of resistance at low power

The 3560 employs a low-power measurement of resistance system that conforms to global standards. This permits accurate measurement of contact resistance without serious damage to the oxide film on the contact surface.

(3) High-speed measurement and high-speed pass/fail judgment

The 3560 is capable of performing both measurement and pass/fail judgment at high speeds, allowing reduced line tact time. Up to thirty comparators can be set and one 3560 conducts pass/fail judgment performed for various measured objects.

(4) Battery measurement

Since the 3560 simultaneously measures resistance and DC voltage, it is capable of making a combined pass/fail judgment possible for internal resistance and open-circuit voltage.

(5) Interface

The 3560 comes with an RS-232C interface, external output terminal, and external control terminal as standard features, allowing data communications with a computer. The instrument also supports optional GP-IB and printer interfaces.

(6) Lead options

The 3560 supports options such as clip-type, pin-type, and four-terminal leads, allowing the user to select the most suitable lead for the shape of the particular object being measured.

(7) Excellent visibility and ergonomics

The fluorescent character display allows measurements to be read in poorly-lit areas, and low switch hierarchy allows for easy and intuitive operation.

1.3 Identification of Controls and Indicators

1.3.1 Fluorescent Character Display Tube

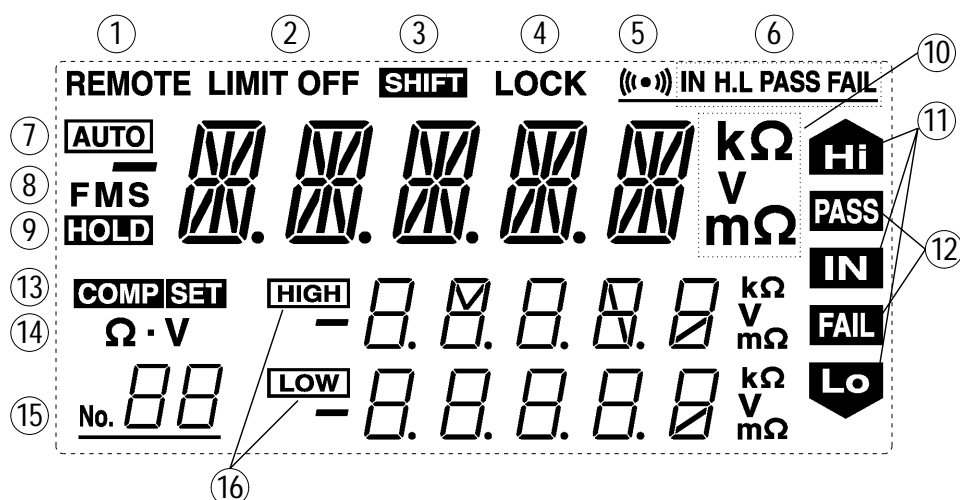

- ① **REMOTE** This indicator lights to indicate control through RS-232C or GP-IB interfaces.
- ② **LIMIT OFF** This indicator lights to indicate that open-circuit terminal voltage is not limited to 20 mV.
- ③ **SHIFT** This symbol appears when this key is pressed, and disappears when any other key is pressed.
- ④ **LOCK** This indicator lights to indicate that the key lock is active.
- ⑤ **Buzzer (1)** This symbol indicates that the buzzer is enabled.
- ⑥ **Buzzer (2)** This indicator displays the buzzer setting for the selected comparator.
- ⑦ **AUTO** This symbol appears to indicate that the resistance or voltage range is set to auto-range.
- ⑧ **FMS** This indicator displays the sampling rate setting. "F" stands for Fast; "M" stands for Medium; and "S" stands for Slow.
- ⑨ **HOLD** This indicator lights to indicate that the instrument is in hold mode.
- ⑩ **k /V/m** These symbols indicate various instruments.
- ⑪ **Hi/IN/Lo** This symbol indicates comparator operation results in resistance measurement mode.
- ⑫ **PASS/FAIL** This symbol displays comparator operation results in resistance and voltage measurement mode.
- ⑬ **COMP SET** This symbol lights to indicate use of either the comparator function ("COMP" is lit) or set ("COMP SET" is lit).
- ⑭ **·V** This symbol indicates either resistance mode (" " is lit) or resistance and voltage mode (" " is lit)
- ⑮ **No. _____** This symbol indicates the comparator number.
- ⑯ **HIGH/LOW** This symbol indicates the upper and lower limits of the comparator.

1.3.2 Front Panel

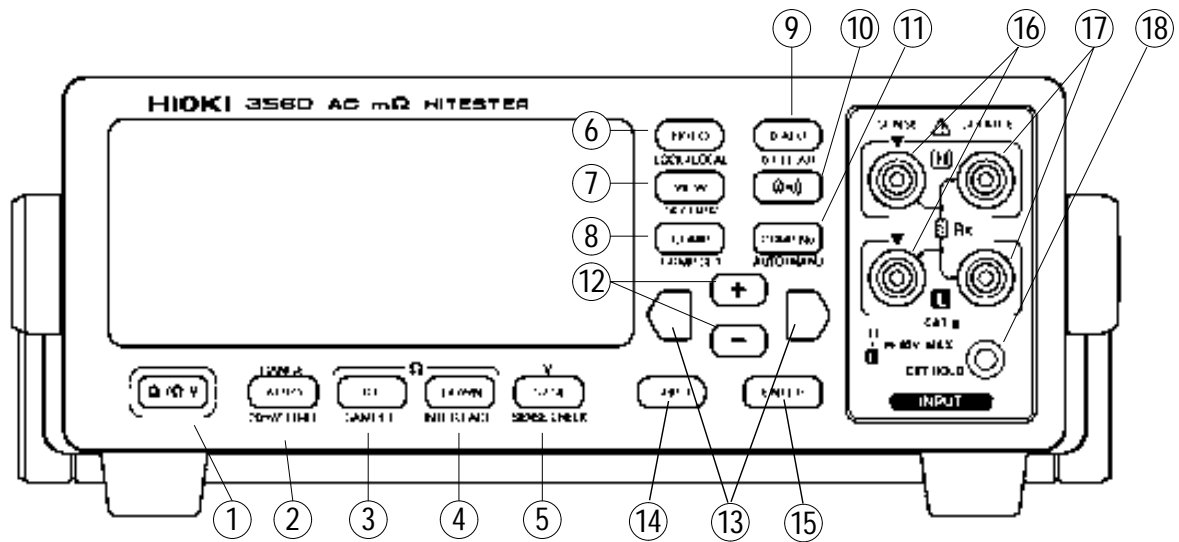

Descriptions in parentheses indicate the operation triggered by pressing the **SHIFT** key.

- | | | |
|---|---|--|
| ① | / ·V | Mode select key
This key is used to select resistance measurement or resistance and voltage measurement mode. |
| ② | AUTO
(20 mV LIMIT) | Auto-range key for resistance and voltage range
(Open-circuit terminal voltage limiter setup key) |
| ③ | UP
(SAMPLE) | Resistance range-setup key
(Sampling select key) |
| ④ | DOWN
(INTERFACE) | Resistance range-setup key
(Selects between RS-232C and GP-IB and provides several settings) |
| ⑤ | 5/50
(SENSE CHECK) | Voltage range-setup key
(Sets broken SENSE line detection function.) |
| ⑥ | HOLD
(LOCK/LOCAL) | Hold mode setup key
(Sets key lock or the mode change from remote to local.) |
| ⑦ | VIEW
(50/60 Hz) | View function setup key
(Sets power supply frequency.) |
| ⑧ | COMP
(COMP SET) | Comparator on/off setup key
(Allows you to access the comparator setup screen.) |
| ⑨ | 0ADJ
(0CLEAR) | Key used to correct the offset for lead impedance and the 3560
(Restores zero-adjust data to default values.) |
| ⑩ | ((•)) | Buzzer on/off setup key |
| ⑪ | COMP No.
(AUTO/MANU) | Comparator number setup key
(Selects between auto and manual comparator output.) |
| ⑫ | +, - CURSOR | Keys used to increase or decrease a selected number
These key are also used to select character strings in various setup screens. |
| ⑬ | ◀ ▶ CURSOR | Keys used to move the cursor in the comparator setup screen in order to select numbers, words, or characters |
| ⑭ | SHIFT | Key to press before shift operations |
| ⑮ | ENTER | Key used to determine settings and to enable measurement modes |
| ⑯ | SENSE | Terminal to which the SENSE lead terminal is connected |
| ⑰ | SOURCE | Terminal to which the SOURCE lead terminal is connected |
| ⑱ | EXT HOLD | Terminal to which the optional 9466 REMOTE CONTROL SWITCH is connected |

1.3.3 Rear Panel / Side Panel

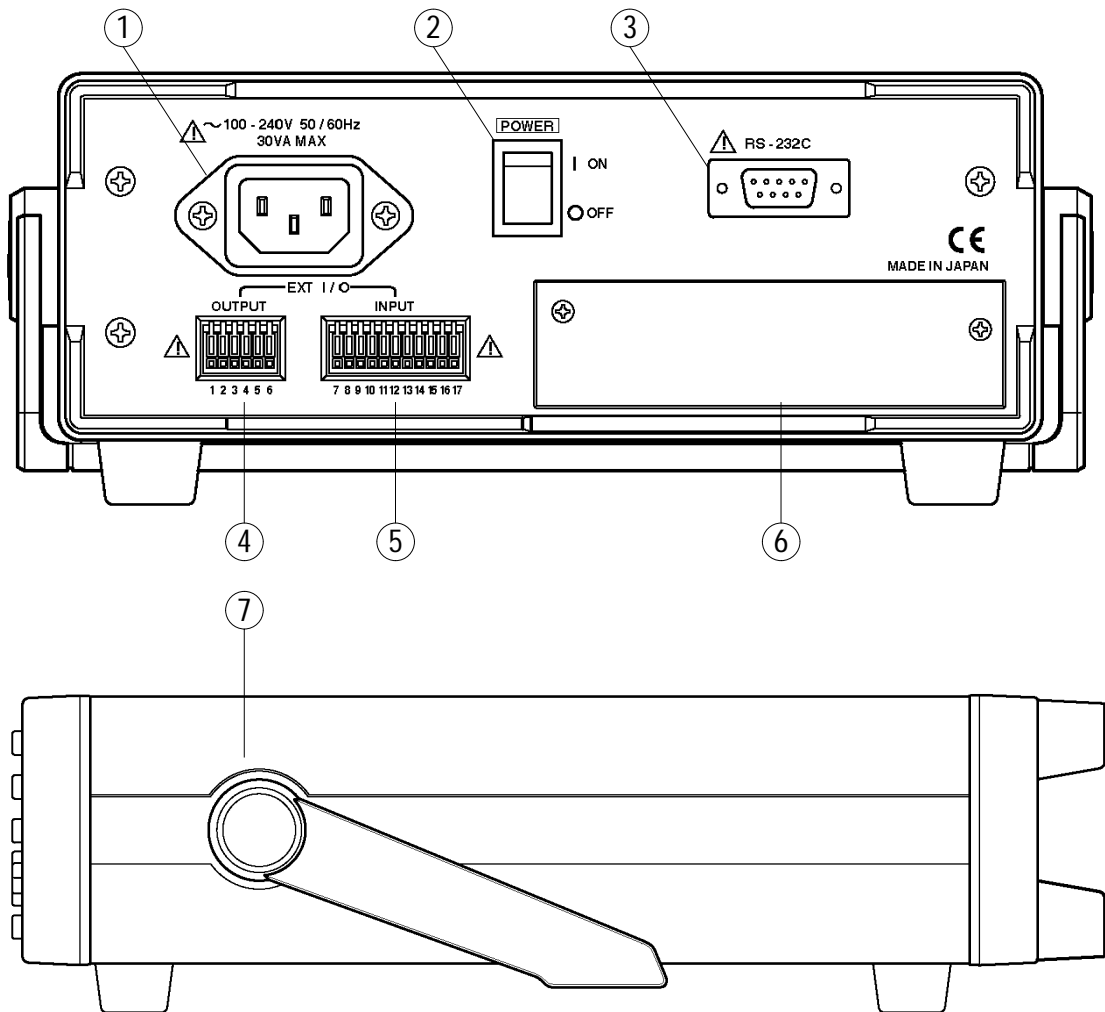

- | | | |
|---|----------------------------------|--|
| ① | POWER INLET | Terminal to which the power cord is connected (built-in fuse type) |
| ② | POWER SWITCH | Switch used to switch on power |
| ③ | RS-232C INTERFACE | RS-232C interface terminal |
| ④ | EXTERNAL OUTPUT TERMINAL | Data output terminal |
| ⑤ | EXTERNAL CONTROL TERMINAL | Terminal used for external control of the instrument |
| ⑥ | BLIND PANEL | Slot for optional interface instrument |
| ⑦ | STAND (HANDLE) | Stand (also used as a handle) |

Chapter 2

Specifications

2.1 General Specifications

Measurement method	Resistance AC four-terminal method
A/D method	- method with sample hold function
Sampling rate	Rated supply frequency: 50 Hz FAST 50 samples/sec 20.0 ms MEDIUM 6.25 samples/sec 160 ms SLOW 1.56 samples/sec 640 ms 60 Hz FAST 60 samples/sec 16.7 ms MEDIUM 7.52 samples/sec 133 ms SLOW 1.88 samples/sec 533 ms
Response time (When a non-inductive resistance is measured)	Rated supply frequency: 50 Hz FAST 100 ms MEDIUM 800 ms SLOW 1.92 s 60 Hz FAST 84 ms MEDIUM 667 ms SLOW 1.60 s Response time may be determined by the measured object.
Open-circuit terminal voltage	20 mVp max. (When limiter is ON)
Input overflow	"OF" display
Current abnormality	"-----" display
Comparator mode switch	Switchable between AUTO and MANU
Comparator number	30 sets
Comparator buzzer	[Resistance measurement mode]: The buzzer sounds if the comparator results is Hi,Lo or IN. [Resistance and voltage measurement mode]: The buzzer sounds if the comparator results is PASS or FAIL.
Hold function	Holds the display value.
Zero adjust function	Revision of induced voltage in circuits and measurement leads.
Zero clear function	Restores zero-adjust data to default values.
View function	Displays both the measured value and comparator setting.
Buzzer function	Turns the buzzer on or off while using the comparator.
Broken SENSE line detection	Detects a broken SENSE line.

External control terminals	[CMOS input] Measurement trigger (TRIG), Comparator trigger (MANU), Printer (PRINT), Zero-adjustment (0ADJ), Digital ground (GND), Comparator number selection (COMP0 to COMP4), External power supply terminal (EXT.DCV)
External output terminals	[Open collector output] (35 VDC max, 50 mA max.) Comparator results (Hi (FAIL), IN (PASS), Lo (FAIL))* End-of-output conversion signals (EOC) Measurement irregularity signal (NG), Digital ground (GND) *: Words in parentheses indicate output in resistance and voltage measurement mode.
RS-232C I/F	Standard
GP-IB I/F	Option
Printer I/F	Option, Centronics (can be connected the 9203 DIGITAL PRINTER)
Operating temperature and humidity range	0 to 40 (32 to 104°F), 80%RH or less (no condensing)
Storage temperature and humidity range	- 10 to 50 (14 to 122°F), 80%RH or less (no condensing)
Operating temperature and humidity for guaranteed accuracy	23 ± 5 (73 ± 9°F), 80%RH or less (no condensing)
Period of guaranteed accuracy	1 year
Location for use	Indoor, altitude up to 2000 m (6566 feet)
Rated supply voltage	100 V /110 V /120 V /200 V /220 V /240 V AC (A voltage variation of ± 10% is considered for the rated power supply voltage.), Rated supply frequency: 50/60 Hz
Maximum rated power	30 VA
Maximum input voltage	60 VDC max (AC voltage cannot be input.)
Dielectric strength	2.3 kVrms for 1 minute / between power supply line (L,N) and the Protective ground terminal (dielectric strength measured within the inlet)
Dimensions	215W × 80H × 320D mm(8.46"W × 3.15"H × 12.6"D) approx. (excluding protrusions)
Mass	2.1 kg (74.1 oz) approx. (not including options)
Accessories	9287-10 CLIP TYPE LEAD, Instruction manual, Basic Instructions, Power cord
Options	9455 PIN TYPE LEAD 9461 PIN TYPE LEAD 9467 LARGE CLIP TYPE LEAD 9452 CLIP TYPE LEAD 9453 FOUR TERMINAL LEAD 9466 REMOTE CONTROL SWITCH 9454 ZERO ADJUSTMENT BOARD 9588 GP-IB INTERFACE 9151-02 GP-IB CONNECTOR CABLE (2 m) 9151-04 GP-IB CONNECTOR CABLE (4 m) 9589 PRINTER INTERFACE 9203 DIGITAL PRINTER 9425 CONNECTION CABLE (for connecting the 3560 to the 9203/2-meters) 9233 RECORDING PAPER (for the 9203/10meters, 10rolls)
Applicable standards	EMC: EN 61326:1997+A1:1998+A2:2001+A3:2003 EN 61000-3-2:2000, EN 61000-3-3:1995+A1:2001 Safety: EN 61010-1:2001 Pollution degree: level 2 Effect of radiated radio-frequency electromagnetic field: 4% f.s. at 3V/m (resistance measurement) Effect of conducted radio-frequency electromagnetic field: 15% f.s. at 3V (resistance measurement)

2.1 General Specifications

2.2 Measurement Range

Resistance measurement

Sampling rate: SLOW, MEDIUM

Temperature coefficient: ($\pm 0.05\%$ rdg. ± 0.8 dgt.)/

Range	Maximum indication	Resolution	Measurement current	Accuracy (6 months)	Accuracy (1 year)
30 m	31.000 m	1 μ	7.4 mA	$\pm 0.5\%$ rdgt. ± 8 dgt. (3 dgt.)	$\pm 0.7\%$ rdgt. ± 8 dgt. (3 dgt.)
300 m	310.00 m	10 μ	1 mA		
3	3.1000	100 μ	100 μ A		
30	31.000	1 m	10 μ A		
300	310.00	10 m	5 μ A		
3 k	3.1000 k	100 m	1.5 μ A		

* If the sampling rate is set to MEDIUM, add () to the digit accuracy error.

Sampling rate: FAST

Temperature coefficient: 30 m range ($\pm 0.05\%$ rdg. ± 0.8 dgt.)/
: the other range ($\pm 0.05\%$ rdg. ± 0.6 dgt.)/

Range	Maximum indication	Resolution	Measurement current	Accuracy (6 months)	Accuracy (1 year)
30 m	31.00 m	10 μ	7.4 mA	$\pm 0.5\%$ rdgt. ± 8 dgt.	$\pm 0.7\%$ rdgt. ± 8 dgt.
300 m	310.0 m	100 μ	1 mA		
3	3.100	1 m	100 μ A		
30	31.00	10 m	10 μ A		
300	310.0	100 m	5 μ A		
3 k	3.100 k	1	1.5 μ A		

Measurement current accuracy: $\pm 10\%$

Measurement current frequency Accuracy: 1 kHz ± 0.2 Hz

Voltage measurement

Sampling rate: SLOW, MEDIUM, FAST

Temperature coefficient: ($\pm 0.005\%$ rdg. ± 0.5 dgt.)/

Range (V)	Maximum indication (V)	Measurement current (V)	Accuracy (6 months)	Accuracy (1 year)
5	± 5.0000	100 μ	$\pm 0.05\%$ rdgt. ± 5 dgt.(3dgt.) 【5 dgt.】	$\pm 0.07\%$ rdgt. ± 5 dgt.(3dgt.) 【5 dgt.】
50	± 50.000	1 m		

* If the sampling rate is set to MEDIUM, add () to the digit accuracy error.

* If the sampling rate is set to FAST, add 【 】 to the digit accuracy error.

2.3 External Dimensions

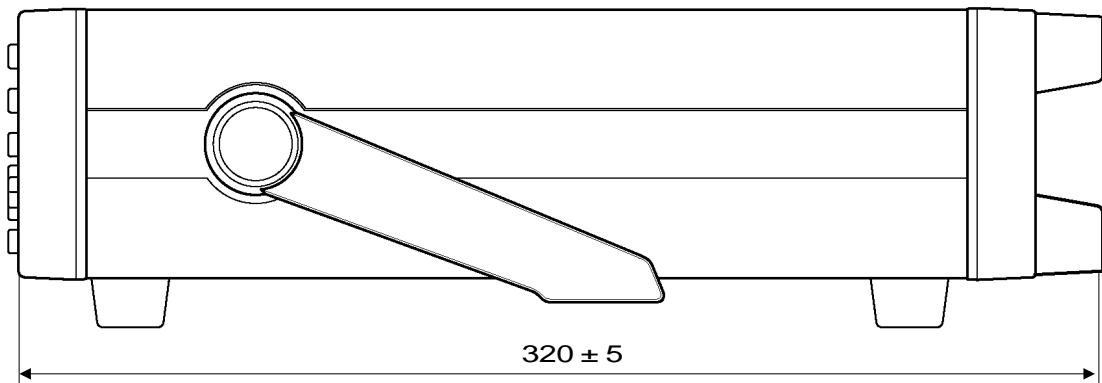
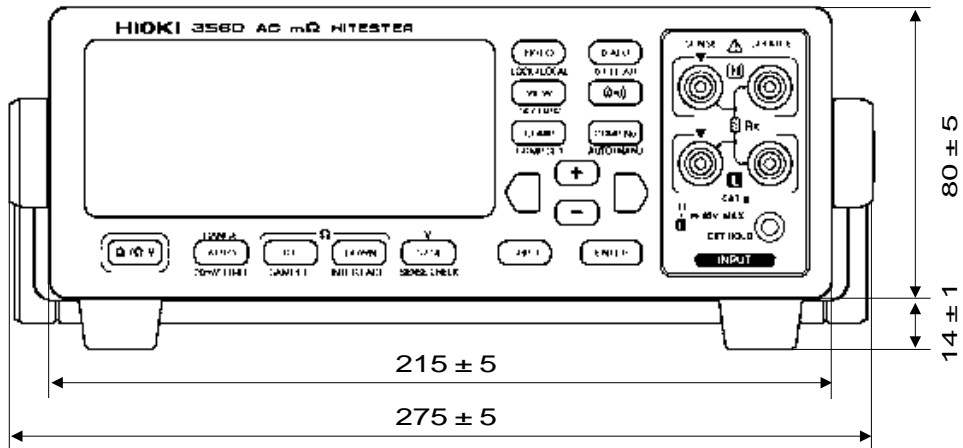

Chapter 3

Preparing for Measurement

3.1 Mounting the Interface

WARNING

- To avoid electric shock accident, before removing or replacing an interface, confirm that the instrument is turned off and that the power cord is disconnected. The mounting screws must be firmly tightened or the interface may not perform to specifications, or may even fail.
- To avoid the danger of electric shock, never operate the instrument with an interface removed. To use the instrument after removing an interface, install a blank panel over the opening of the removed module.

CAUTION

To avoid damage to the instrument, do not short-circuit the output terminal or connector and do not input voltage to the output terminal or connector. When the interface is removed, place a blank panel over the opening. This keeps the instrument's internal temperature uniform and within specifications.

The 9588 GP-IB INTERFACE or 9589 PRINTER INTERFACE can be mounted to the instrument.

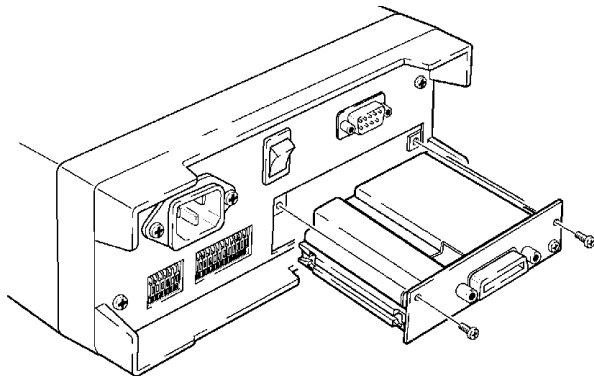

NOTE

- Mount only a 9588 or 9589 interface.
- The resistance or voltage can be measured even if the interfaces is not mounted.
- The printer and GP-IB interfaces cannot be used simultaneously. Mount either interface.

An expansion slot for an interface is covered by a blank panel on the rear panel of the instrument. To mount an interface, remove this panel in the following manner:

1. Remove the blank panel. (Retain the set bolts.)
2. Insert the interface into the guide rails.
3. Firmly press the interface into the slot until fully inserted, and secure with the set bolts from Step 1.

3.2 Connecting the Power Cord



WARNING

- Before turning the instrument on, make sure the source voltage matches that indicated on the instrument's power connector. Connection to an improper supply voltage may damage the instrument and present an electrical hazard.
 - To avoid electrical accidents and to maintain the safety specifications of this instrument, connect the power cord only to a 3-contact (two-conductor + ground) outlet.
-

Connect the power cord in the following manner:

1. Confirm that the instrument is off.
2. Make sure the power supply voltage matches power requirements, and connect the power cord to the power inlet on the rear panel of the instrument.
3. Plug the other end of the power cord into the AC outlet.

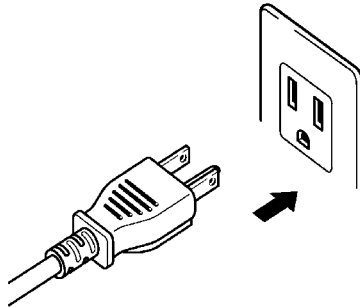

3.3 Connecting the Measurement Leads



Connect the 9287-10 CLIP TYPE LEAD as shown in the following figure. Connect leads to all SOURCE+, SOURCE-, SENSE+, and SENSE- terminals.

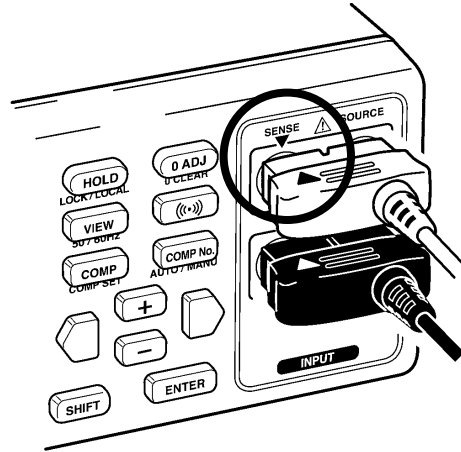

The instrument is red symbol should correspond to the red symbol on the lead, and the instrument is black symbol should correspond to the black symbol on the lead.

NOTE

Extension of measurement leads is normally performed by Hioki. Consult your dealer or Hioki representative if you require this service. If you plan to extend the measurement leads yourself, see Section 10.3, "Configuration and Extension of the Measurement Leads."

3.4 Powering On/Off

Powering ON

1. Turn on the rear panel **POWER** switch (set the switch to the position marked as "1.") The initial screen appears in the display.
2. A diagnostic self-test runs to test ROM and RAM devices for errors. Error messages are displayed for defective items. No error messages are displayed for passed items. For information on error messages, see Section 11.1 "Message Code Table."
3. If the self-test finishes without errors, the instrument enters normal measurement mode.

Powering OFF

Turn off the rear panel **POWER** switch (set switch to the position marked "0.") All measurement parameters are saved.

NOTE

After switching on the instrument, allow it to warm up for at least 60 min before performing measurements.

3.5 Setting the Power Supply Frequency

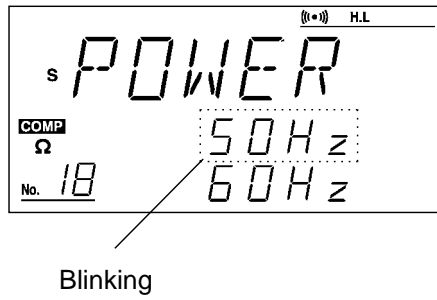

1. Press the **SHIFT** key. "SHIFT" appears lit in the display.
2. Press the **VIEW (50/60 Hz)** key. The power supply frequency setup screen appears as shown to the left, with the current frequency flashing.
3. Press the **+** and **-** keys to select the power supply frequency. The selected frequency will flash.
4. Press the **ENTER** key to set the selected power supply frequency. The system returns to measurement mode.

NOTE

Failure to set the correct power supply frequency will prevent accurate measurement. Make sure the correct frequency is set.

3.6 Instrument Handle

⚠ CAUTION

When using the handle as a stand for the device, do not press down too hard on the device as this can damage the handle.

The handle can be used as a stand. Pull both ends of the handle outward to release it and rotate it to the desired position. Then, push the handle inward to lock it in place. The handle can be locked at interval of 22.5 degrees.

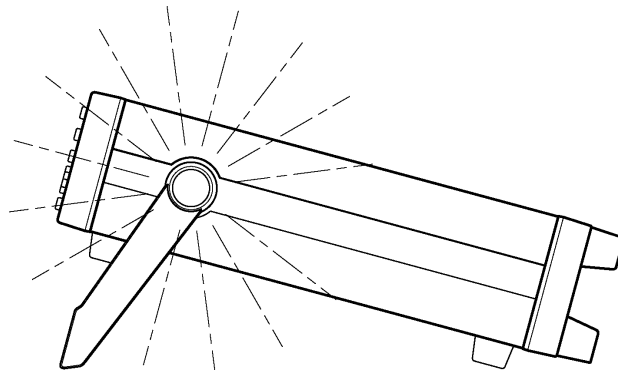

Chapter 4

Measurement Procedure

The following flowchart outlines a basic measurement sequence.

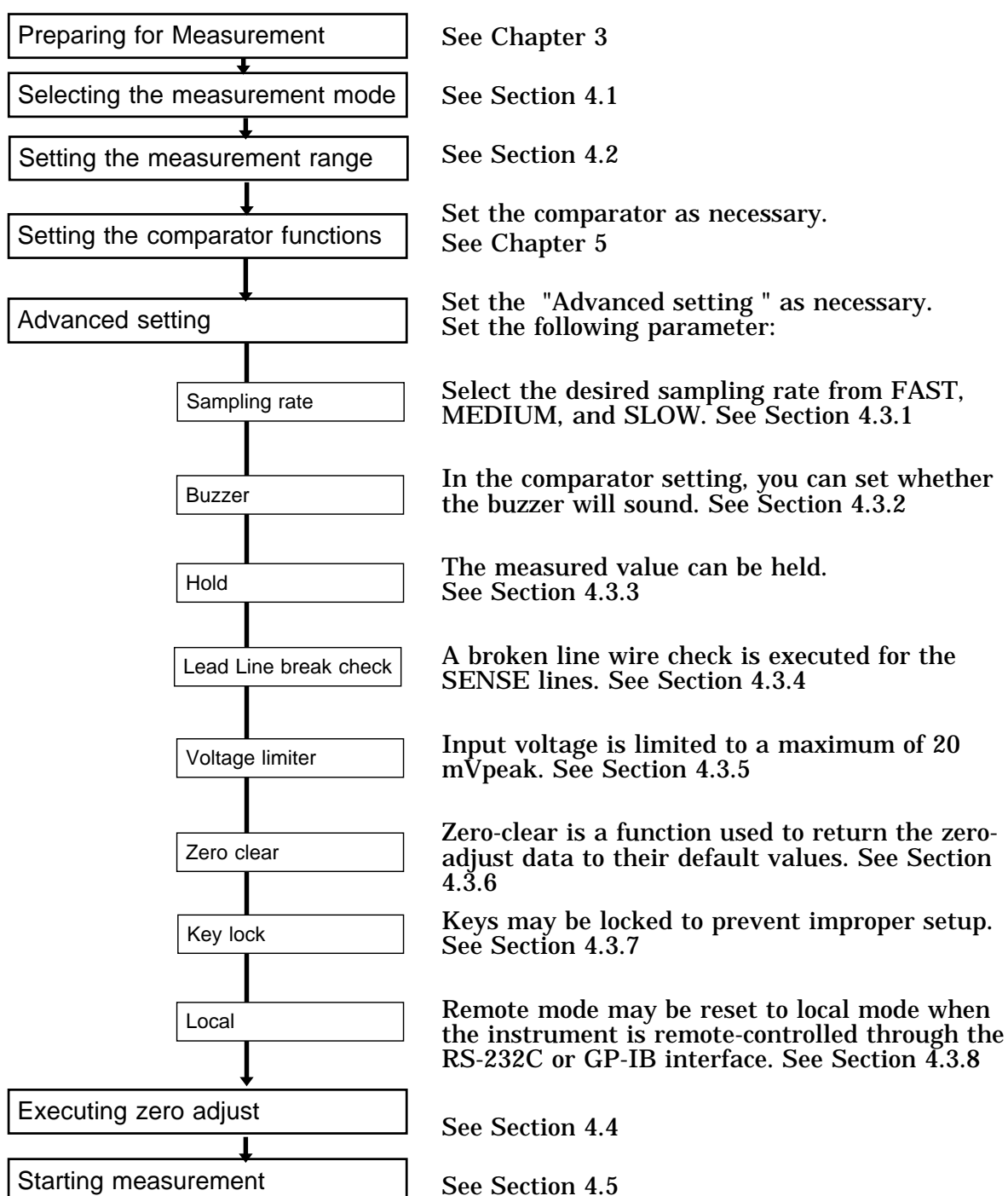

4.1 Selecting the Measurement Mode

Resistance measurement mode

The resistance measurement mode is primarily used to measure the contact resistance of relays, for example.

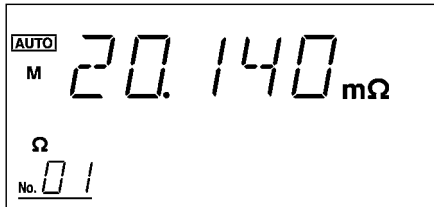

1. Press the Ω key to select resistance mode.
2. In resistance mode, only the " Ω " symbol for " \cdot V" will appear lit in the display.

Resistance and voltage measurement mode

The resistance and voltage mode is used primarily for simultaneous measurement of a battery's internal resistance and open-circuit voltage.

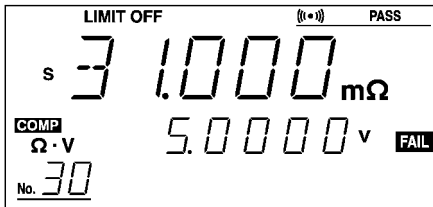

1. Press the Ω key to select resistance and voltage mode.
2. In resistance and voltage mode, " \cdot V" appears lit in the display.

4.2 Setting the Measurement Range

The resistance range and voltage range (resistance and voltage mode only) may be set in the manual range mode.

(1) Setting the resistance range

Use the **UP**, **DOWN**, and **AUTO** keys to select the desired range.
Press the **AUTO** key to select auto-range.

Sampling: FAST				Sampling: MEDIUM, SLOW			
Range ()	Maximum indication ()	Resolution ()	Measurement current (A)	Range ()	Maximum indication ()	Resolution ()	Measurement current (A)
30 m	31.00 m	10 μ	7.4 m	30 m	31.000 m	1 μ	7.4 m
300 m	310.0 m	100 μ	1 m	300 m	310.00 m	10 μ	1 m
3	3.100	1 m	100 μ	3	3.1000	100 μ	100 μ
30	31.00	10 m	10 μ	30	31.0000	1 m	10 μ
300	310.0	100 m	5 μ	300	310.00	10 m	5 μ
3 k	3.100 k	1	1.5 μ	3 k	3.1000 k	100 m	1.5 μ

(2) Setting the voltage range (resistance and voltage mode only)

Use the **5/50** key to select the desired range.
Press the **AUTO** key to select auto-range.

Range (V)	Maximum indication (V)	Resolution (V)
5	± 5.0000	100 μ
50	± 50.000	1 m

NOTE

- When the **AUTO** key is pressed in the auto range mode, the auto range mode is changed to the manual range mode while the current measurement range is maintained.
- When auto-range is selected, both resistance and voltage ranges are set to auto-range mode.
- If the range is not determined in auto-range mode, perform a zero-adjust. For more information, see Section 4.4 "Zero Adjust."
- When the voltage limiter is used in the 3 k range, it may be activated by external noise, causing "-----" to appear on the display. In such a case, turn off the voltage limiter.
- When the auto range mode is in hold status, only the current range is zero-adjusted.
- When triggering occurs with the auto range mode in hold status, waveforms are measured in the current range.
- If the SOURCE line is broken, voltages cannot be measured correctly.

4.3 Advanced Setting

4.3.1 Sampling Rate

Sampling refers to the operation by which measurements are converted into digital values. Sampling time refers to the duration over which sampling occurs, from beginning to end of sampling. The inverse of the sampling time is called the sampling rate. With this instrument, you may choose between FAST, MEDIUM, and SLOW sampling rates.

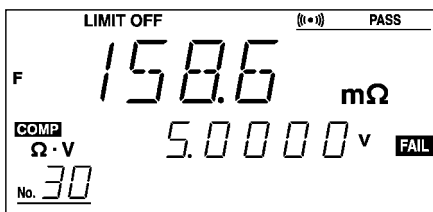

1. Press the **SHIFT** key. "SHIFT" appears lit on the display.
2. Press the **UP (SAMPLE)** key.

When changing sampling rates, the settings will cycle through the available settings in the order FAST (F) MEDIUM (M) SLOW (S) FAST (F)... etc.

NOTE

- When changing the sampling rate, alter resistance and voltage settings simultaneously. For a FAST sampling rate, the maximum resistance setting is 3100 counts.
- For more information on sampling rates, see Chapter 2 "Specifications."

4.3.2 Buzzer

When the buzzer is set to ON in the "Comparator Setup" screen, the buzzer can be set to sound according to the result of comparator operation. For proper buzzer setup procedures, see Chapter 5 "Comparator Function."

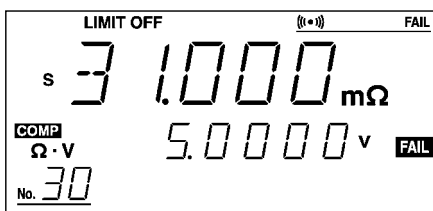

Buzzer: ON

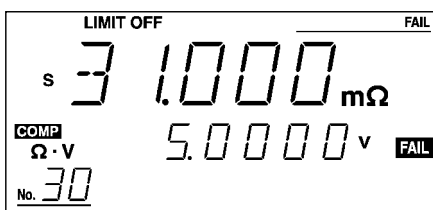

Buzzer: OFF

1. Pressing the **COMP** key toggles the comparator on. "COMP" appears lit on the display.
2. Pressing the **(••)** key toggles the buzzer on or off. If the buzzer is enabled in the comparator setting, the **(••)** symbol appears, and the buzzer sounds according to the current comparator setting. If the buzzer is disabled in the comparator setting, the **(••)** symbol does not appear and the buzzer no longer sounds.

NOTE

If the buzzer is set to OFF in the "Comparator Setup" screen, the buzzer sound setting cannot be changed from ON to OFF and vice versa.

4.3.3 Hold

The measured value can be held. The hold function may be used with the trigger function (available via the external control terminal). For more information on the trigger function, see Section 6.3.1 "External Control Terminal"

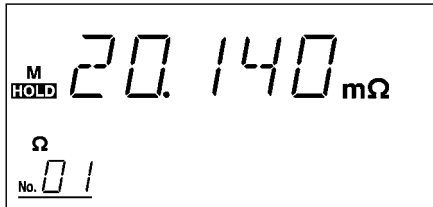

1. Pressing the **HOLD** key displays "HOLD" and holds the measured value.
2. Press the **HOLD** key again to cancel this mode.

NOTE

- When the range is changed in hold status, the held data are erased.
- When the measurement mode is changed in hold status, the displayed voltage may not be output to the RS-232C and GP-IB, or irrelevant values may be displayed on the screen. Before changing the measurement mode, perform the setting again.

Using the EXT. HOLD terminals, the same effect as the hold key can be obtained.

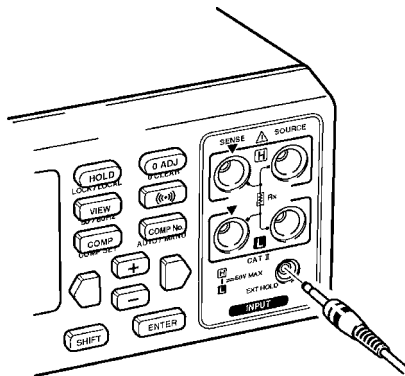

1. Remove the lead from battery to be tested.
2. Insert the mini-plug of the 9466 to the EXT.HOLD terminal.
3. Press the 9466 switch for at least 200 ms to obtain the effect of pressing the **HOLD** key. The "hold" indication appears in the display, and the measurement values are held.
4. To release the hold condition, press the 9466 switch for at least 200 ms again or press the **HOLD** key.

9466 REMOTE CONTROL SWITCH

The 9465 PIN TYPE LEAD and 9466 REMOTE CONTROL SWITCH can be combined as shown below. (The 9455 PIN TYPE LEAD and 9461 PIN TYPE LEAD can be also combined with the 9466.)

Connect the switch to the probe of the lead, and join the two cables using the supplied spiral tube.

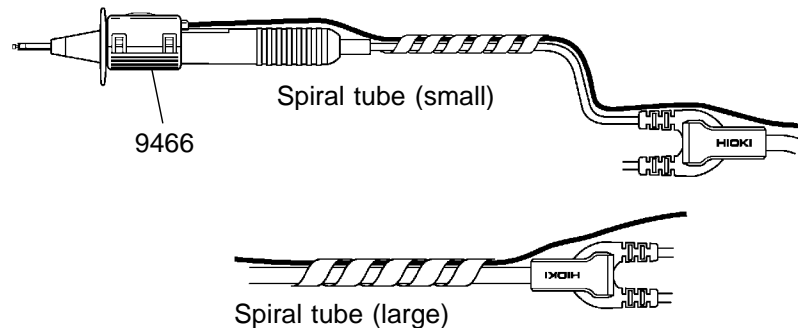

NOTE

- Do not insert or remove the mini-plug while the lead is connected to the batteries. Before replacing the plug, always remove the lead from the batteries.
- If the spiral tube has a sharp edge at the end, round it with scissors to prevent possible injury.

4.3.4 Lead Line Break Check (Imperfect Contact Check)

SOURCE line break check

The 3560 measures resistance using the AC constant-current system. With this method, an AC constant current is unlikely to be supplied due to a broken SOURCE line or the resistance of the measurement object. Since using normal measurement procedures in such circumstance will produce incorrect resistance measurements, the system checks the SOURCE line for breaks. If a break is detected, " - - - - - " appears in the measured value display field, and the associated signal is output to the external output terminal. For external output terminal details, see Section 6.3.2 "External Output Terminal."

NOTE

The SOURCE line break check cannot be disabled.

SENSE line break check

The SENSE line is examined for breaks. If a break is detected, " - - - - - " appears in the measured value display zone, and the associated signal is output to the external output terminal. For external output terminal details, see Section 6.3.2 "External Output Terminal." The SENSE line break check may be disabled or enabled.

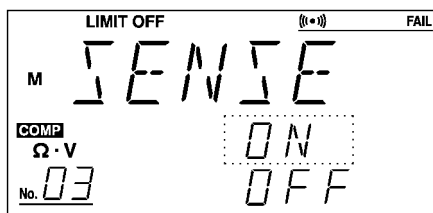

1. Press the **SHIFT** key. "SHIFT" appears lit on the display.
2. Press the **5/50 (SENSECHECK)** key. The screen changes to the SENSE line-break check screen.
3. Press the **+** and **-** keys to select ON/OFF. The selected mode will flash.
4. Press the **ENTER** key.

NOTE

- Breaks in the SENSE line are detected with a 2-kHz low AC current applied between the SENSE line and measured object, as well as the measurement current.
- An extended lead will create a capacitive load and possible lead to an incorrect implementation of the SENSE line break check. When using a nonstandard lead, be sure to short-circuit the SOURCE line to open the SENSE line, and make sure the broken line check is implemented correctly.
- When this setup screen is active, only the **+**, **-**, **SHIFT**, and **ENTER** keys are enabled.

4.3.5 Voltage Limiter

The voltage limiter may be set. If set, the voltage applied to the measured object is limited to a maximum of 20 mV_{peak} in order to protect the oxide film on the contact surface of the object.

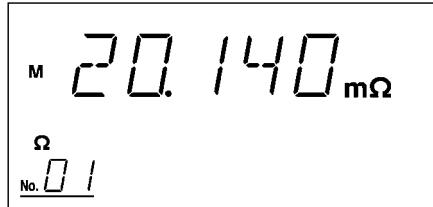

Limiter: ON

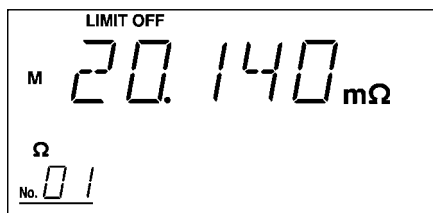

Limiter: OFF

1. Press the **SHIFT** key. "SHIFT" appears lit on the display.
2. Press the **AUTO (20 mV LIMIT)** key. "LIMIT OFF" appears from the display, and the limiter is turned off.
3. The above operation toggles the limiter on or off.

NOTE

- The voltage limiter is enabled before shipment. Since measurements may be unsuccessful if the lead is modified or extended with the voltage limiter enabled, shorten the measurement lead to reduce resistance or disable the voltage limiter.
- For more information on the voltage limiter, see Section 10.6 "IEC 512-2, JIS C 5402 and JIS C 5441."
- To shut off the DC current, the SOURCE and SENSE terminals of the instrument are equipped with capacitors. The voltage limiter will not work when these capacitors are charged. If you measure an element having electromotive force, such as a battery, then measure its contact resistance, you must first short-circuit the measurement lead once to neutralize the charge in the capacitors.
- The open-circuit terminal voltage between SENSE-Hi and SOURCE-Hi does not guarantee 20 mV. When using 9453 FOUR TERMINAL LEAD, avoid crossing the red and black leads.

4.3.6 Zero Clear

Zero-clear is a function used to return the zero-adjust data to their default values.

1. Press the **SHIFT** key. "SHIFT" appears lit on the display.
2. Press the **0 ADJ (0 CLEAR)** key.
3. The zero-adjust data in full resistance and voltage ranges are returned to their default values. The system returns to measurement mode after zero-clear is complete.

4.3.7 Key Lock

Keys may be locked to prevent improper setup.

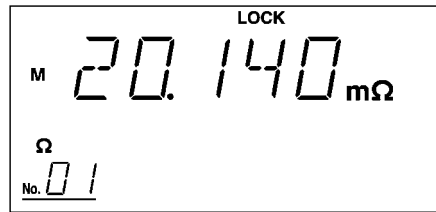

Key lock active

Set the key lock function in the following manner:

1. Press the **SHIFT** key. "SHIFT" appears lit on the display.
2. Press the **HOLD (LOCK/LOCAL)** key. "LOCK" appears in the display to indicate that keys are locked.

Cancel the key lock function in the following manner:

1. Press the **SHIFT** key. "SHIFT" appears lit on the display.
2. Press the **HOLD (LOCK/LOCAL)** key. "LOCK" disappears from the display, and the key lock is canceled.

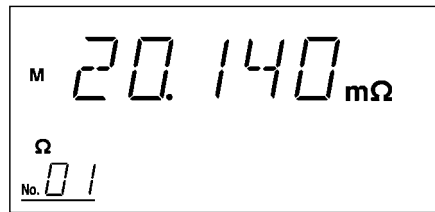

Key lock canceled

4.3.8 Local

When the instrument is remote-controlled through an RS-232C or GP-IB interface, the remote mode may be changed to local mode. When local mode is active, manual operations are available, including key operation. Local mode does not affect the key lock function. For information on turning the key lock function on and off, see Section 4.3.7 "Key Lock."

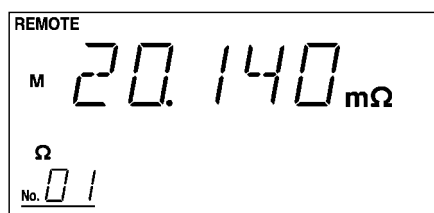

Remote mode active

1. Press the **SHIFT** key. "SHIFT" appears lit on the display.
2. Press the **HOLD (LOCK/LOCAL)** key. "REMOTE" disappears from the display, and the **REMOTE** is canceled.

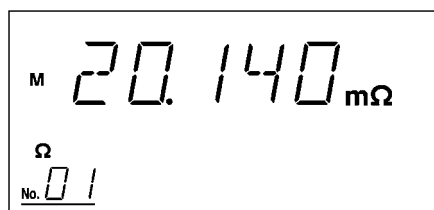

Remote mode canceled

NOTE

The remote mode can not be enabled by the key operations.

4.4 Zero Adjust

For accurate measurements, zero-adjust needs to be performed before measurement. Zero-adjust is also available with the EXT.I/O terminal. For more information on the EXT.I/O terminal, see Section 6.3.1 "External Control Terminal"

1. Connect the leads as shown below.
2. When the value observed in the display stabilizes, press the **0ADJ** key.
3. After zero-adjust is completed, the system returns to measurement mode.

9453

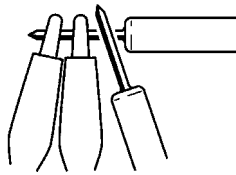

Perform zero adjustment with the alligator clips placed attached to the outside of the unit and the lead rod on the inside.

9287-10

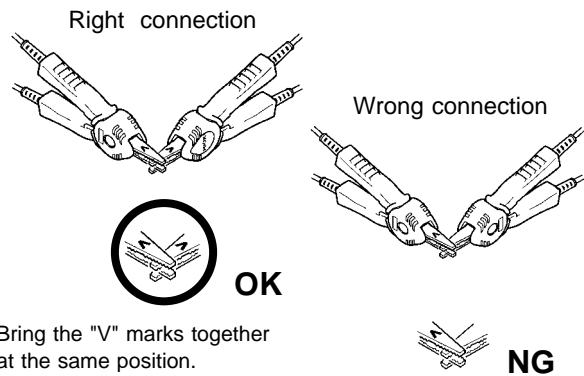

Bring the "V" marks together at the same position.

9452

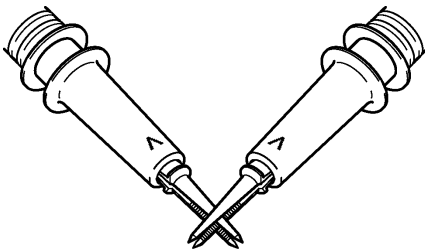

9461

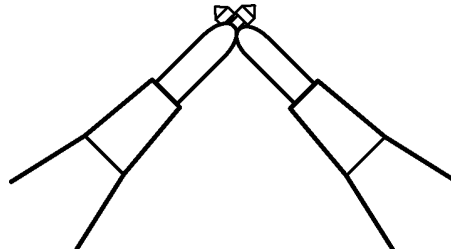

9467

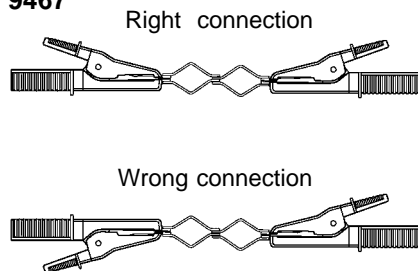

9465

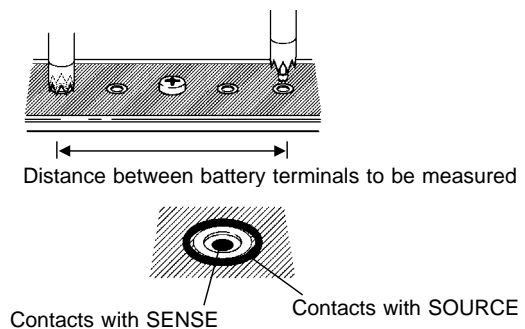

NOTE

- To make a zero adjustment of the 9453, turn off SENSE CHECK. Following the adjustment, SENSE CHECK may be turned on.
- The zero-adjust can be used for up to 2400 counts in measuring resistance (240 counts for FAST sampling rate) and up to 3400 counts in measuring voltage. If an attempt is made to use the zero-adjust beyond these limits, "ERR-1" appears in the display to prevent further zero-adjust operations. Perform a zero-adjust whenever you change sampling rates.
- The voltage is input to the 3560 for measurement. If the voltage input is 3400 counts or more at zero adjustment, "ERR-1" appears and the zero adjustment is invalidated even in the resistance measurement mode.
- The value determined upon zero clearing is a reference for the possible zero adjustment range.
- Whenever the sampling rate is changed, a zero adjustment should be made.
- For 9455 PIN TYPE LEAD, first conduct the zero-adjust for 9287-10 CLIP TYPE LEAD, then replace the 9287-10 leads with 9455 PIN TYPE LEAD and conduct a zero-adjust for the 9455 leads.
- Zero adjustment can also be performed by the 9461 when the 9454 ZERO ADJUSTMENT BOARD is used.
- When the zero adjustment is made in the auto range mode, it is applied to the entire range.
- When the system is put in the HOLD mode while the zero adjustment is being made in the auto range mode, "ERR-1" appears. In this case, cancel the hold status and execute the zero adjust again.
- When the system is in HOLD mode, the currently displayed value is zero-adjusted.

4.5 Starting Measurement

⚠ DANGER

- Be sure to ensure the floating state for a battery circuit (measured object) with voltage exceeding 30 Vrms, 42.4 Vpeak, or 60 VDC. Connecting the instrument to a circuit exceeding 30 Vrms, 42.4 Vpeak, or 60 VDC may lead to electric shock.
- To avoid electrical shock, be careful to avoid shorting live lines with the measurement leads.
- Do not measure the voltage of the voltage generator, as doing so will cause an AC voltage to be applied to the output terminal of the voltage generator, resulting in a hazard.
- When a high-voltage battery has been measured and a low-voltage battery is to be measured, short-circuit the measurement lead to discharge the DC component cutoff capacitor of the 3560. Otherwise, an overvoltage will be applied to the battery.

Connect the lead to the measured object and read the measured value.

9287-10

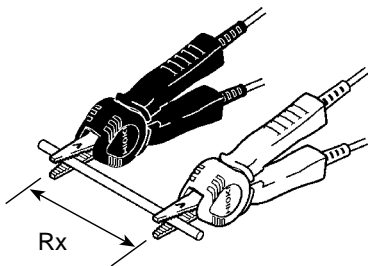

Measurement of resistance

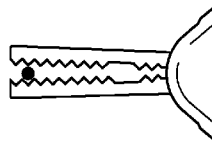

When clipping a thin line
Clip the line at the tip,
serrated part of the jaws.

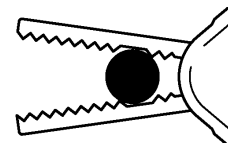

When clipping a thick line
(Clip the line at the deep,
non-serrated part of the jaws.)

9465

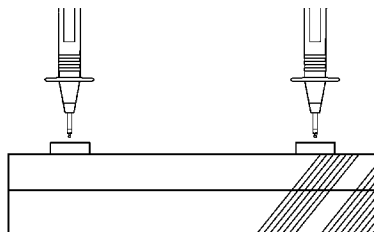

Measurement of battery internal resistance

9452

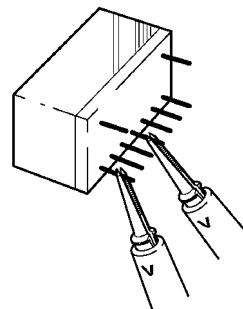

Measurement of relay contact resistance

NOTE

- The value displayed may fluctuate if equipment generating magnetic fields is located near the 3560, such as electric motors. If fluctuations are observed, install the instrument in a location at a distance from the equipment.
- Objects having inductance of 5 μ H or greater may produce incorrect measurements.
- Do not pile the 3560 instruments for measurement.
- Note that if the tested object is placed on the instrument or close to the indicator, measurements may fluctuate due to generated noise.

In case of abnormal measurements (NG)

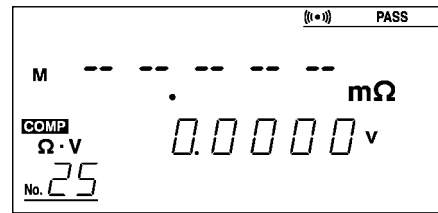

When the 3560 monitors the measurement process and judges the measurement to be incorrect, it outputs an abnormal measurements (NG) signal, displaying " - - - - " on the fluorescent character display.

Abnormal measurements include the following events:

- Broken SOURCE line
- The SOURCE is not connected to the measured object.
- The lead resistance of the SOURCE line and the contact resistance and resistance of the measured object and reactance deviate from the valid ranges for each parameter. For valid ranges, refer to the following table.

An abnormal measurement signal is output when any of the following events occurs. For allowable ranges, see the table below.

- The SENSE line break check is turned on, and a break has occurred in the SENSE line.
- The SENSE line break check is turned on, but the SENSE line is not connected to the measured object.
- If the induced voltage is greater than the internal signal processing level, it is generated between the SOURCE and SENSE lines. Extending the measurement lead increases induced voltage. If the coil capacitor has large reactance, the induced voltage may exceed the internal signal processing level.
- Immediately following a change in sampling rate
- Immediately following a change in range

Allowable ranges for SOURCE lead resistance, contact resistance, and resistance of the measurement object

Figures provided in this table are for reference only; their accuracy is not guaranteed.

Resistance range ()	Lead resistance and contact resistance	SENSE line break check / Voltage limiter			
		OFF/ON ()	OFF/ON ()	ON/OFF ()	ON/OFF ()
30 m	RC1+RL+RC2 RC2	1.4 900 m	400 m 400 m	1.4 300 m	400 m 300 m
300 m	RC1+RL+RC2 RC2	13 7.5	5 5	13 13	5 3.3
3	RC1+RL+RC2 RC2	125 76	55 55	130 34	55 34
30	RC1+RL+RC2 RC2	990 760	260 260	990 333	260 200
300	RC1+RL+RC2 RC2	2.3 k 1.5 k	890 890	2.3 k 640	890 520
3 k	RC1+RL+RC2 RC2	8.7 k 5.1 k	3.9 k 3.9 k	8.7 k 1.9 k	3.9 k 330

RL: Measurement object

RC1: "Hi" lead resistance + contact resistance

RC2: "Lo" lead resistance + contact resistance

*: RL = F.S.

Chapter 5

Comparator Function

5

With the comparator function, the instrument compares the measured value to the predetermined upper and lower limits to determine, based on set conditions, where the measured value falls in this range, then displays and outputs the result. The following flowchart illustrates the setup sequence.

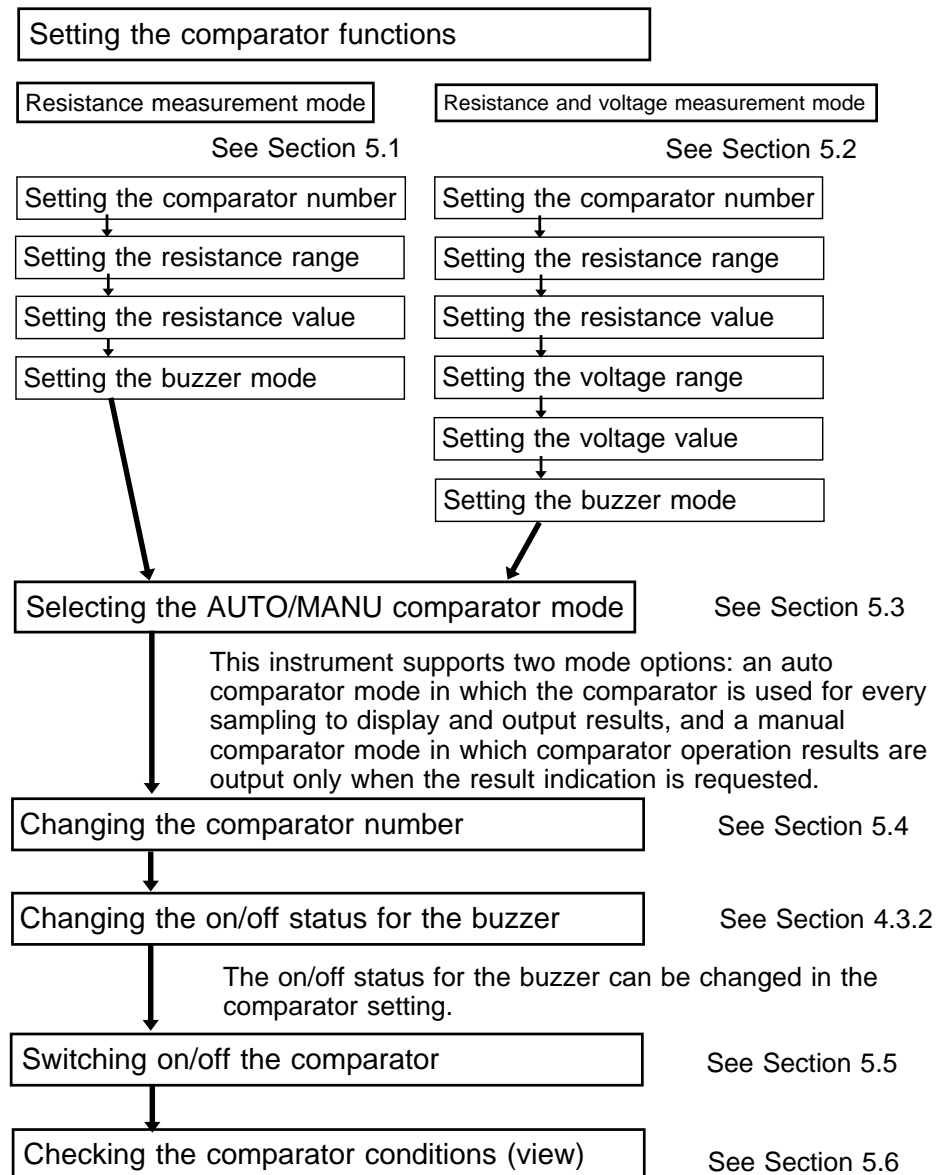

Use the View function to check the upper and lower limits of the currently set comparator.

5.1 Resistance Measurement Mode

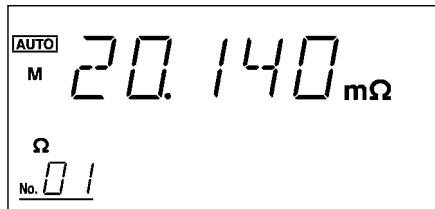

(1) Setting start

1. Press the **SHIFT** key. "SHIFT" appears lit in the display.
2. Press the **COMP (COMP SET)** key. The display switches to the comparator setup screen.
3. Press the **/ · V** key to select resistance mode. In resistance mode, the screen displays only the "Ω" symbol of "/ · V" as lit.

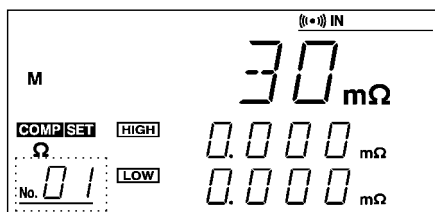

The comparator number blinks.

(2) Setting the comparator number

On the comparator setup screen, "COMP SET" is lit and the comparator number flashes. Use the **+** and **-** keys to select the desired comparator number. You may select numbers in the range from 01 to 30.

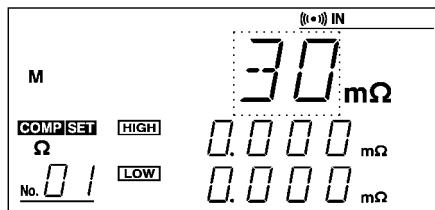

(3) Setting the resistance range

1. Use the **▷** (cursor right move) key to select the resistance range setup field.
2. Use the **+** and **-** keys to set the resistance range. Select a value within the range 30 mΩ to 3 kΩ.

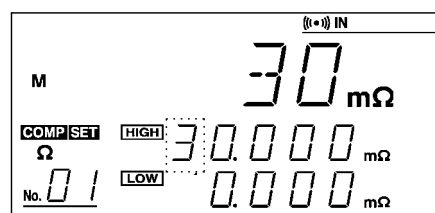

(4) Setting the resistance value

1. Use the **▷** (cursor right move) key to select the resistance upper limit setup field.
2. Use the **+**, **-**, and **◀ ▶** (cursor left and right move) keys to set the upper resistance. Select values in the effective range 0 to 31000.
3. Set the resistance lower limit.

NOTE

Set these values so that the resistance lower limit is not higher than the resistance upper limit. If the values set violate this rule, the instrument will regard the smaller resistance as the lower limit and larger resistance as the upper limit and execute the comparator function. Determine all five digits for each limit value. If the sampling rate is set to FAST, the comparator function is executed by rounding down the lowest digit. Auto-range cannot be selected.

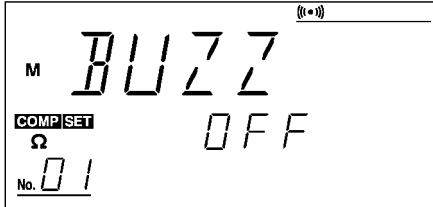
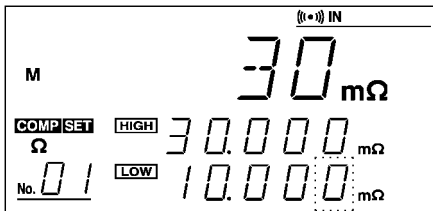

OFF

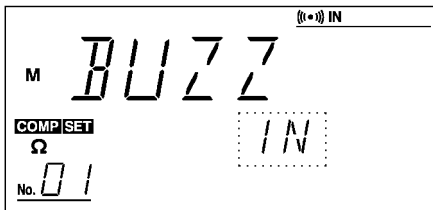

The buzzer sounds at Hi

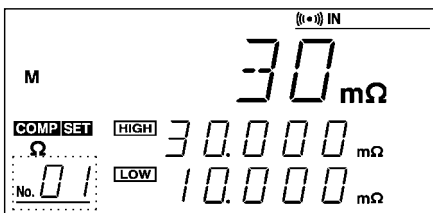

(5) Setting the buzzer mode

1. Use the \triangleright (cursor right move) key to select the last digit of the resistance lower limit setup field.
2. Press the \triangleright (cursor right move) key again to display the buzzer setup screen.
3. Use the + and – keys to set the buzzer. Select a mode from three available options: "OFF", "IN", "HiLo."

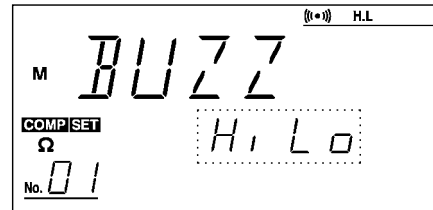

The buzzer sounds at Hi or Lo.

(6) Setting end

Press the ENTER key to exit comparator setup. The system returns to the measurement screen. When the \triangleright is pressed, the screen changes to "(2) Comparator number setup." The next comparators can then be set continuously.

5.2 Resistance and Voltage Measurement Mode

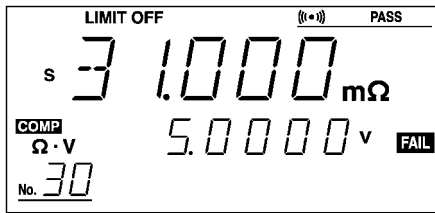

(1) Setting start

1. Press the **SHIFT** key. "SHIFT" appears lit in the display.
2. Press the **COMP (COMP SET)** key. The display switches to the comparator setup screen.
3. Press the **/ · V** key to select resistance and voltage mode. In resistance and voltage mode, the screen displays the " · V" symbol.

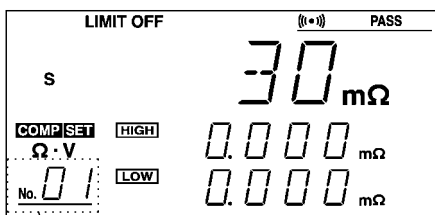

The comparator number blinks.

(2) Setting the comparator number

On the comparator setup screen, "COMP SET" is lit and the comparator number flashes. Use the **+** and **-** keys to select the desired comparator number. You may select numbers in the range from 01 to 30.

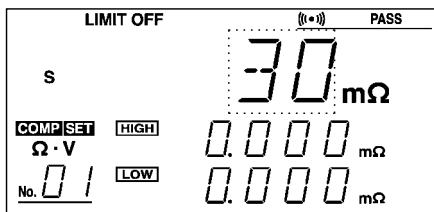

(3) Setting the resistance range

1. Use the **▷** (cursor right move) key to select the resistance range setup field.
2. Use the **+** and **-** keys to set the resistance range. Select a value within the range 30 m to 3 k .

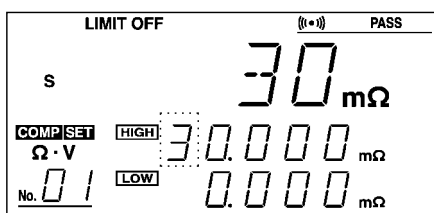

(4) Setting the resistance value

1. Use the **▷** (cursor right move) key to select the resistance upper limit setup field.
2. Use the **+**, **-**, and **◀ ▶** (cursor left and right move) keys to set the upper resistance. Select values in the effective range 0 to 31000.
3. Set the resistance lower limit.

NOTE

- Set these values so that the resistance lower limit is not higher than the resistance upper limit. If the values set violate this rule, the instrument will regard the smaller resistance as the lower limit and larger resistance as the upper limit and execute the comparator function. Determine all five digits for each limit value. If the sampling rate is set to FAST, the comparator function is executed by rounding down the lowest digit.
- Auto-range cannot be selected in resistance range.
- If the voltage range setup screen is not active, check whether the measurement mode has been set to the resistance and voltage measurement mode. If " · V" is observed on the bottom left of the screen, the resistance and voltage measurement mode is active.

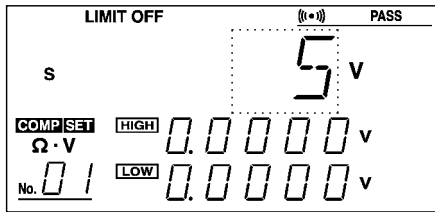

(5) Setting the voltage range

1. Use the \triangleright (cursor right move) key to select the voltage lower limit setup field. Press the \triangleright (cursor right move) key again to select the voltage range setup field.
2. Use the + and – keys to select voltage range. You can select the 5V or 50 V range.

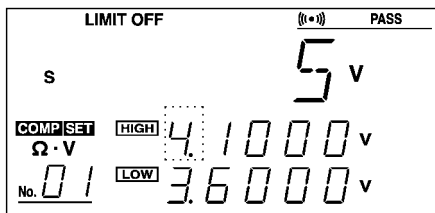

(6) Setting the voltage value

1. Use the \triangleright (cursor right move) key to select the voltage upper limit setup field. Press the \triangleright (cursor right move) key again to select the voltage range setup field.
2. Use the +, –, and (and \triangleleft \triangleright (cursor left and right move) keys to set an upper limit within the effective range -50000 to 50000. Set the voltage lower limit.

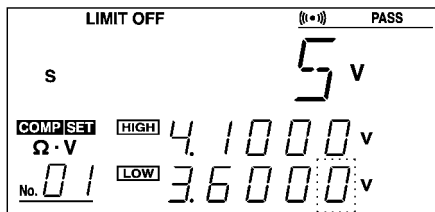

(7) Setting the buzzer mode

1. Use the \triangleright (cursor right move) key to select the last digit of the voltage lower limit setup field.
2. Press the \triangleright (cursor right move) key again to display the buzzer setup screen.
3. Use the + and – keys to set the buzzer. Select a mode from three available options: "OFF", "PASS", "FAIL"

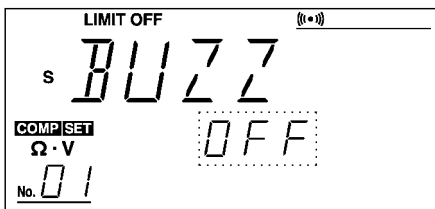

OFF

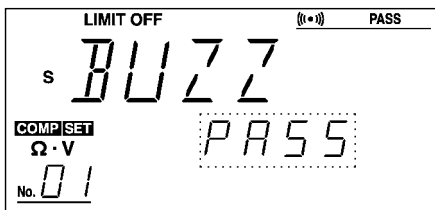

The buzzer sounds at PASS

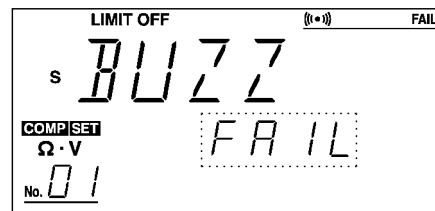

The buzzer sounds at FAIL

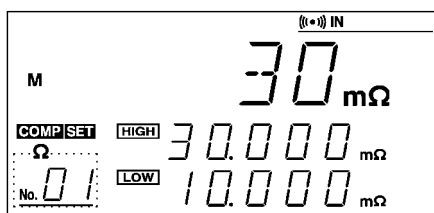

(8) Setting end

Press the ENTER key to exit comparator setup. The system returns to the measurement screen. When the \triangleright (cursor right-movement) key is pressed, the screen is changed to "(2) Comparator number setup." The next comparators can then be set continuously.

5.3 Selecting the AUTO/MANU Comparator Mode

Selecting the AUTO/MANU Comparator Mode

This instrument supports two mode options: an auto comparator mode in which the comparator is used for every sampling to display and output results, and a manual comparator mode in which comparator operation results are output only when the result indication is requested. The current mode (MANU or AUto) flashes in the comparator auto/manual setup screen.

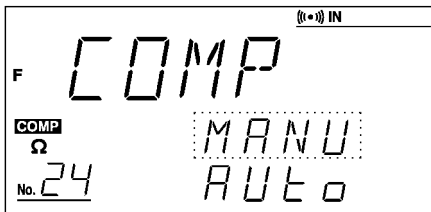

1. Pressing the **COMP** key toggle the comparator on. "COMP" appears lit on the display.
2. Press the **SHIFT** key. "SHIFT" appears lit on the display.
3. Press the **COMP No. (AUTO/MANU)** key to display the comparator auto/manual setup screen.
4. Use the **+** and **-** keys to select MANU or AUto. The selected mode will flash.
5. Press **ENTER** to exit the comparator auto/manual setup screen. The system returns to the measurement screen.

NOTE

- The manual comparator setting is enabled only for the external output terminal. The manual comparator cannot be used for the display or the buzzer.
- For more information on the manual comparator, see Chapter 6 "External Control Terminal and External Output Terminal."
- When this setup screen is active, only the **+**, **-**, **SHIFT**, and **ENTER** keys are enabled.

5.4 Changing the Comparator Number

Change the comparator number using the procedure shown below. For information on using the comparator, see Section 5.5 "Switching On/Off the Comparator."

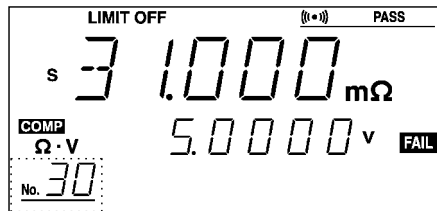

The comparator number blinks.

1. Press the **COMP No.** key to display the comparator number setup screen. The comparator number on the screen will flash.
2. Use the **+**, **-** keys to select a desired comparator number in the range 01 to 30.
3. Press the **ENTER** key to activate the measurement mode associated with the setting determined by the selected comparator number.

NOTE

- The comparator number set is saved when the instrument is shut down.
- The comparator number can be changed even in View mode. For more information on view function, see Section 5.6 "Checking the Comparator Conditions (View)"

5.5 Switching On/Off the Comparator

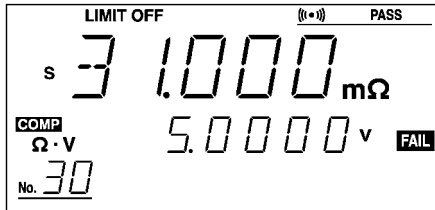

Comparator: ON

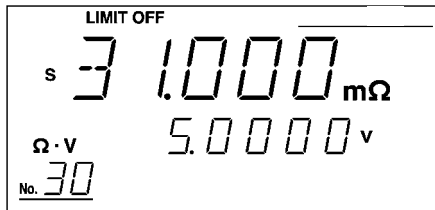

Comparator: OFF

Pressing the **COMP** key toggles the comparator on and off. When the comparator is on, "COMP" appears lit on the display and the comparator function is executed. When the comparator is off, "COMP" is not lit, and the comparator function does not execute.

NOTE

- If the manual comparator is selected, the comparator function is executed while the instrument is controlled via the EXT.I/O terminal. For more information, see Section 5.3 "Selecting the AUTO/MANU Comparator Mode."
- Changing the resistance or voltage range automatically turns off the comparator. Press the **COMP** key to use the comparator. This activates the range set in the comparator.
- In the absence of a measured value, "- - - - -" appears, and the comparator function is disabled.

Comparator comparison table

Judgment results are output to the display according to the table below.

Comparator output (Resistance measurement mode)

Resistance	Hi (Amber)	IN (Green)	Lo (Amber)
------------	--------------	--------------	--------------

Comparator output (Resistance/voltage measurement mode)

Resistance \ Voltage	Hi	IN	Lo
Hi	FAIL (Red)	FAIL (Red)	FAIL (Red)
IN	FAIL (Red)	PASS (Green)	FAIL (Red)
Lo	FAIL (Red)	FAIL (Red)	FAIL (Red)

The boundary condition is as follows:

- Resistance Lo < Lower resistance limit Resistance IN
- Resistance IN Upper resistance limit < Resistance Hi
- Voltage Lo < Lower voltage limit Voltage IN
- Voltage IN Upper voltage limit < Voltage Hi

When the upper limit is equal to the lower limit, the boundary condition is changed as follows:

- Resistance Lo Lower resistance limit = Resistance IN
- Resistance IN = Upper resistance limit < Resistance Hi
- Upper resistance limit < Resistance Hi
- Voltage Lo Lower voltage limit = Voltage IN
- Voltage IN = Upper voltage limit < Voltage Hi

5.6 Checking the Comparator Conditions (View)

VIEW is a function allowing the current comparator setting to be checked. The upper and lower limits of both the resistance and voltage can also be checked. Since the VIEW key does not affect the current comparator setting, this function should be used in the measurement and pre-operation check while the upper and lower limits of the comparator are checked.

5.6.1 View in Comparator of Resistance Measurement Mode Setting

When the resistance measurement mode has been set to the comparator, the upper and lower limits of the resistance can be displayed.

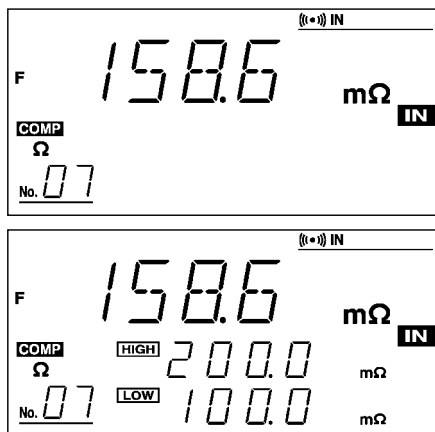

1. Pressing the **VIEW** key toggles display of the comparator upper and lower limits observed in the comparator number field on or off. Measurement continues even during operation. In the resistance measurement mode, the voltage is measured internally, but the measured voltage is not displayed.
2. Press the **VIEW** key once more to stop display of the upper and lower limits of the comparator.

NOTE

- The comparator number may be changed while using the **VIEW** key. For more information, see Section 5.4 "Changing the Comparator Number."
- When the resistance measurement mode is currently active but the **VIEW** function is used for the comparator on which the resistance/voltage measurement mode has been set, the measured value is not displayed in the measured-voltage display field.
- View is a function used to check the settings of the selected comparator. Therefore, the View mode is not affected by the current measurement mode.

5.6.2 View in Comparator of Resistance and Voltage Measurement Mode Setting

When the resistance/voltage measurement mode has been set to the comparator, the upper and lower limits of both the resistance and voltage can be displayed.

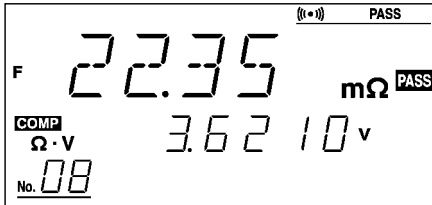

1. Pressing the **VIEW** key stops displaying the measured voltage, displaying instead the upper and lower limits of the resistance comparator observed in the comparator number field.

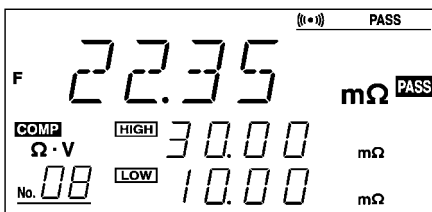

2. Pressing the **VIEW** key again stops display of the measured resistance, displaying instead the measured voltage. In parallel with this action, the screen displays the upper and lower limits of the voltage comparator observed in the comparator number field.

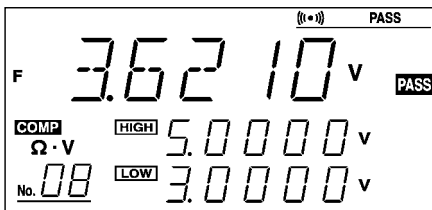

3. When the **VIEW** key is pressed again, the upper and lower limits of the comparator disappear and the system returns to the measurement screen.

NOTE

- The comparator number may be changed while using the **VIEW** key. For more information, see Section 5.4 "Changing the Comparator Number."
- When the resistance measurement mode is currently active but the **VIEW** function is used for the comparator on which the resistance/voltage measurement mode has been set, the measured value is not displayed in the measured-voltage display field.
- In the resistance and voltage measurement mode, the resistance (and/or voltage) not displayed on the screen is also measured.

Chapter 6

External Control Terminal and External Output Terminal

The 3560 is provided with external control and output terminals and supports the RS-232C interface and the optional GP-IB interface connector and printer interface. The external control terminal permits use of the measurement trigger, comparator trigger, printer trigger, and zero-adjust, comparator selection functions.

Results of comparator operation and signals indicating abnormal measurements and end of measurement are output from the external output terminal. Use these functions to establish a measurement sequence for the line.

6.1 Terminals and Signals

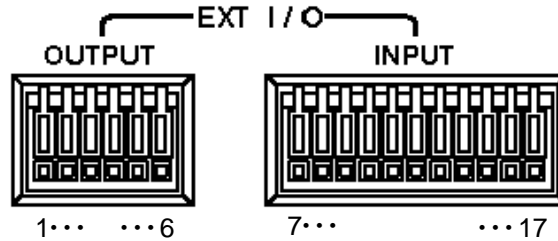

External control terminals

No.	Terminal	Meaning
7	GND	Digital ground This terminal is connected to GND of the external output terminal inside the instrument.
8	TRIG	Measurement trigger terminal This terminal is enabled when the instrument is in hold mode. See the timing chart.
9	MANU	Comparator trigger terminal This terminal is enabled in manual comparator mode. See the timing chart and comparator setting.
10	0ADJ	Zero-adjust control terminal This terminal provides the same function provided by the 0ADJ key.
11	PRINT	Print trigger terminal This terminal is connected to the optional 9203 DIGITAL PRINTER.
12	COMP.0	Comparator selection terminal Comparator conditions are loaded according to the comparator selection table. You may select a comparator from 1 to 30.
13	COMP.1	
14	COMP.2	
15	COMP.3	
16	COMP.4	
17	EXT.DCV	Terminal used to provide power-supply voltage to the instrument from external equipment Allowable power-supply voltages range from +5 to +30 VDC. The external equipment is connected to this terminal via an open-collector output transistor emitter and resistor.

Comparator selection table

COMP					Number	COMP					Number	COMP					Number						
4	3	2	1	0		4	3	2	1	0		4	3	2	1	0							
H	H	H	H	H	No change	H	L	H	H	H	8	L	H	H	H	H	16	L	L	H	H	H	24
H	H	H	H	L	1	H	L	H	H	L	9	L	H	H	H	L	17	L	L	H	H	L	25
H	H	H	L	H	2	H	L	H	L	H	10	L	H	H	L	H	18	L	L	H	L	H	26
H	H	H	L	L	3	H	L	H	L	L	11	L	H	H	L	L	19	L	L	H	L	L	27
H	H	L	H	H	4	H	L	L	H	H	12	L	H	L	H	H	20	L	L	L	H	H	28
H	H	L	H	L	5	H	L	L	H	L	13	L	H	L	H	L	21	L	L	L	H	L	29
H	H	L	L	H	6	H	L	L	L	H	14	L	H	L	L	H	22	L	L	L	L	H	30
H	H	L	L	L	7	H	L	L	L	L	15	L	H	L	L	L	23	L	L	L	L	L	No change

External output terminals

No.	Terminal	Meaning
1	GND	Digital ground This terminal is connected to GND of the external output terminal inside the instrument.
2	Hi	Comparator Hi (FAIL) output
3	IN	Comparator IN (PASS) output
4	Lo	Comparator Lo (FAIL) output
5	EOC	Signal indicating completion of measurement
6	NG	Abnormal measurement indication output Abnormal measurement includes a broken measurement lead or signal processing error.

6.2 Connection Method



CAUTION

- To prevent damage to the instrument, avoid applying voltage or current exceeding the rated value to the external output terminal. Similarly, avoid supplying voltage or current exceeding permissible values to the external control terminal. (Refer to the section listing the instrument's electrical properties.)
- In order to avoid electric shock, turn off the power to all devices before plugging in or unplugging any of the interface connectors. Connect cables securely to prevent disconnection during measurement and inappropriate contact with conductive materials, including the human body.
- When using a relay, connect a counter-electromotive force-absorbing diode.
- Avoid short-circuiting the external output and control terminals. Removing too much of the cable insulation may lead to short-circuits.

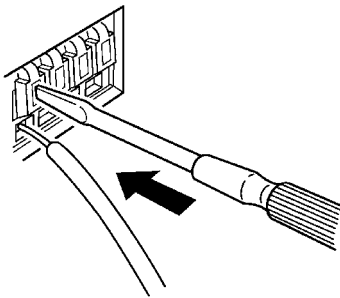

1. Push down the button with an appropriate tool, such as a flathead screwdriver.
2. With the button pushed down, insert the cables into the connection holes.
3. Release the button to secure the cables. Remove the cables using the same procedure.

Recommended wire: Single strand 0.65 mm dia. (AWG #22)
Multi-strand 0.32 mm² (AWG #22)

Usable limits: Single strand 0.32 to 0.65 mm dia. (AWG #22 to #22)
Multi-strand 0.08 to 0.32 mm² (AWG #22 to #22)

Standard insulation stripping length: 10 mm

Button pressing tool: Blade screwdriver (shaft diameter 3, tip width 2.6 mm)

Power rating for external control and output terminals

	Input/output device	Logic	Electrical requirements
Output	Open collector	Negative logic	35 VDC 50 mADC max.
Input (Except for EXT.DCV)	C-MOS	Negative logic	H: 3.8 V to 5.0 V L: 0 V to 1.2 V
EXT.DCV	DC voltage input		

External output terminal-Applications

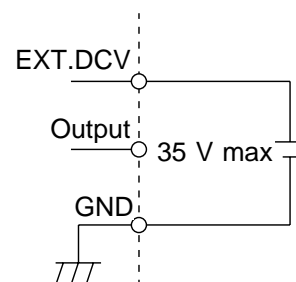
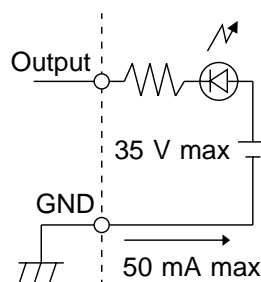
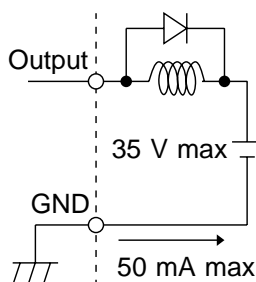

Connection of the relay Connection of the LED lamp Connection of negative logic output

6.3 Measurement by External Control Terminal and External Output Terminal

6.3.1 External Control Terminal (Input Signal)

In the text below, "H" and "L" refer to the following two respective states:
H: No input or input of GND +3.8 to GND +5 V.
L: Input of GND +0 to GND +1.2 V. (Short-circuited to GND)

Measurement trigger (TRIG)

The displayed data is updated when this input signal is changed from "H" to "L" (i.e. the fall edge is created) in measurement-hold mode. For more information on hold mode, see Section 4.3.3 "Hold."

Comparator output request (MANU)

When the external output terminal mode is set to MANU in the comparator setting, the comparator result is output while this input signal remains "L." For more information on comparator settings, see Section 5.1 "Resistance Measurement Mode" and Section 5.2 "Resistance and Voltage Measurement Mode."

Zero-adjust request (0ADJ)

Zero-adjust is implemented when this input signal is changed from "H" to "L" (i.e. the fall edge is created) during measurement. For more information on zero-adjust, see Section 4.4 "Zero Adjust."

Print request (PRINT)

This signal is used to output measurement data from the optional digital printer (9203) or general-purpose Centronics printer. For more information on printers, see Chapter 9 "Printer Interface."

Comparator number selection (COMP0 to COMP4)

Select the comparator number from Section 6.1 "Terminals and Signals." For more information on comparators, see Chapter 5 "Comparator Function."

Hold on/off (EXT HOLD)

Use the 9466 REMOTE CONTROL SWITCH (option) to turn hold mode on or off.

NOTE

The input signal is disabled under the following conditions. Any function dependent on the signal is also disabled.

- Selection of a comparator No. (COMP0 - COMP4) during communications via RS-232 or GP-IB
- The measurement trigger (TRIG) is issued if the instrument is not in hold mode.
- The comparator output request (MANU) is issued if the comparator is not used when the external output terminal mode is set to AUTO in the comparator setting.
- Print request (PRINT) is issued when no printer interface (9589) is connected.
- The comparator number (COMP0 to COMP4) is selected while the comparator setup screen is displayed.
- The measurement trigger (TRIG) is issued while the zero-adjust executes.
- The comparator is automatically turned on and auto-range changed to manual range if the comparator number is selected by the comparator number selection signal (COMP0 to COMP4) while auto-range is used.
- When the comparator number (COMP0 to COMP4) is used, the remote mode is active.

6.3.2 External Output Terminal (Output Signal)

In the following text, "0" and "1" indicate the following two respective states:

0: The output transistor is turned off, and no current flows through it.

1: The output transistor is turned on, and current flows through it.

Comparator result (Hi (FAIL), IN (PASS), Lo (FAIL))

When the result is "1," the comparator result associated with the signal is valid.

End of measurement (EOC)

A change from "0" to "1" in this signal indicates that current measurement is complete, and that the comparator result output is determined.

Abnormal measurements (NG)

A value of "1" indicates an abnormal measurement. This signal is set to "1" even when abnormal measurements are detected in hold mode.

Abnormal measurement results indicate a broken lead, incorrect contact, or defective internal analog circuits. For more information on abnormal measurements, see Section 4.5 "Starting Measurement."

NOTE

- If the comparator is not used, or if the mode of the comparator external control terminal is MANU but the comparator output request (MANU) is not issued, "0" is output for all comparator results (Hi (FAIL), IN (PASS), and Lo (FAIL)). In the NG state, "0" is output for all comparator results (Hi (FAIL), IN (PASS), and Lo (FAIL)).
- If no measurement is carried out after the instrument is turned on, all output signals are set to "0." When the comparator result is FAIL in resistance and voltage mode, Hi (FAIL) and IN (PASS) are simultaneously set to "1."

6.3.3 Timing Chart

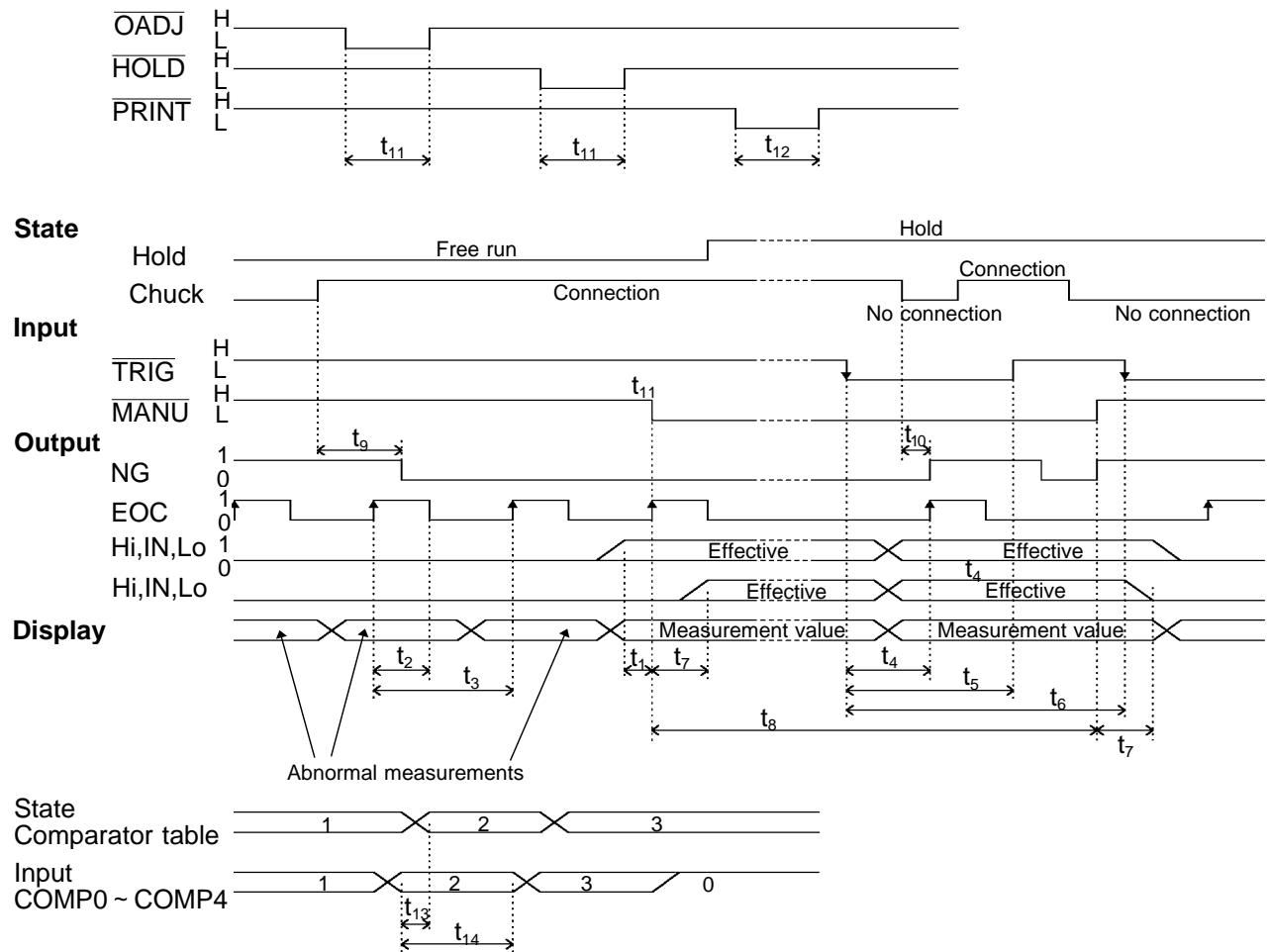

	Description	Time (approx.)		
		MAX	TYP	MIN
t_1		1 ms	-	-
t_2		6 ms	-	4 ms
t_3	Sampling rate	FAST	20 ms(50 Hz) / 16.7 ms(60 Hz)	
		MEDIUM	160 ms(50 Hz) / 133 ms(60 Hz)	
		SLOW	640 ms(50 Hz) / 533 ms(60 Hz)	
t_4	Length of time from measurement trigger to output of EOC	1 ms	-	-
t_5	Measurement-trigger pulse width	-	-	1 ms
t_6	Measurement trigger interval	-	-	1 sampling
t_7	Length of time from MANU to output of comparator	1 ms	-	-
t_8	MANU pulse width	-	-	1 ms
t_9	Length of time from connection of the 3560 to the sample to setting of NG to Lo	-	5 ms	-
t_{10}	Length of time from disconnection of the 3560 from the sample to setting of NG to Hi	1 ms	-	-
t_{11}	OADJ, HOLD pulse width	-	-	15 ms
t_{12}	PRINT pulse width	-	-	1 ms
t_{13}	Length of time from input to change in comparator number	2 s	-	-
t_{14}	Input retention time	-	-	2 s

(1) Selecting Comparator Number

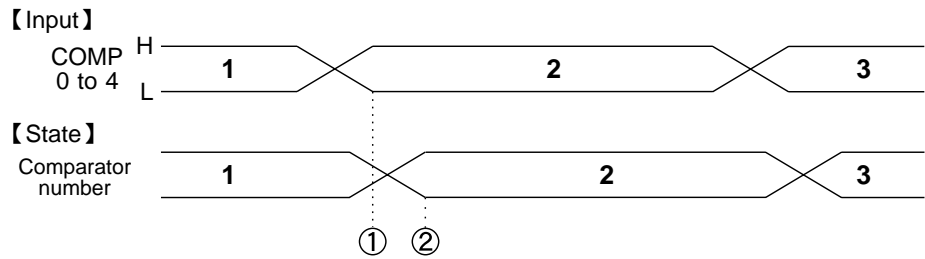

- ① When reselecting comparator number by external control terminal signal, use COMP 0 to 4. After reselecting comparator number, keep the same signal status.
- ② Comparator number is reselected. Starts measurement after 3560 setting is stabilized.

(2) Measurement using trigger function

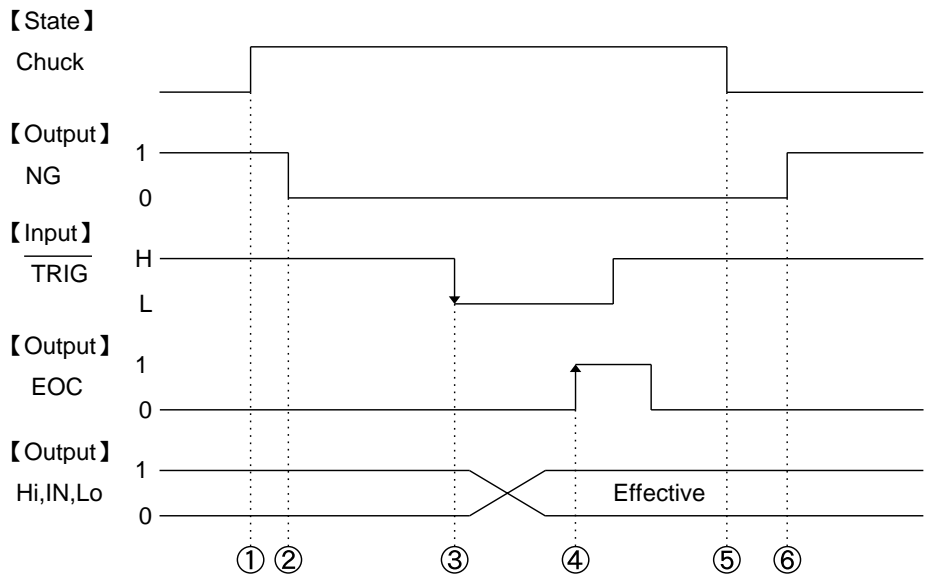

- ① Connect object to be measured to measurement lead.
- ② Measurement error signal(NG) is disengaged.
- ③ TRIG signal is output after time to stabilize is reached.
Invalid when in free run status.
Waiting time (response time) is as follows depending on sampling.
This value applies in the case of pure resistance.
Waiting time varies depending on type of object to be measured.
Adjust it after measurement and when value fluctuates, enter larger value.

	FAST	MEDIUM	SLOW
Frequency: 50 Hz	Approx.95 ms	Approx.795 ms	Approx.1.92 s
Frequency: 60 Hz	Approx.80 ms	Approx.660 ms	Approx.1.60 s

- ④ Removes object to be measured
- ⑤ Outputs measurement error signal (NG). Repeats processes from ③.

(3) Measurement Using MANU Function

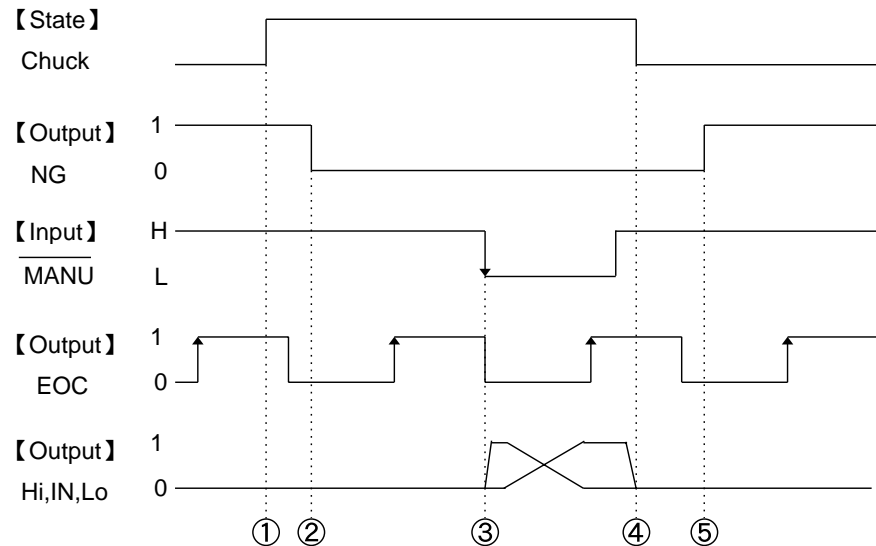

- ① Connect object to be measured to measurement lead.
- ② Measurement error alarm signal(NG) is disengaged.
- ③ MANU signal is output after time to stabilize.
Waiting time (response time) is as follows depending on sampling.
This value applies in the case of pure resistance. Waiting time varies depending on type of object to be measured.
Adjust it after measurement and when value fluctuates, enter larger value.
When MANU signal is input, it outputs latest data from completed measurement at the time.

	FAST	MEDIUM	SLOW
Frequency: 50 Hz	Approx.95 ms	Approx.795 ms	Approx.1.92 s
Frequency: 60 Hz	Approx.80 ms	Approx.660 ms	Approx.1.60 s

- ④ Remove resistance being measured.
- ⑤ Outputs measurement error signal (NG). Repeats processes from ③.

NOTE

- When loading measurement result using TRIG signal, be sure to monitor EOC signal status and load measurement result after EOC signal is output. When loading measurement result without monitoring EOC signal, load data after TRIG signal is input and some time has passed.
- Comparator result (Hi,IN,Lo,PASS,FAIL) is not output in the following situations.
 - When comparator is set to MANU and MANU signal is not input.
 - When NG (measurement error) occurs. (See 4.5 Starting Measurement)
- When connecting 9203 printer to 3560 and print measurement value synchronized with measurement, use 9425 CONNECTION CABLE only for connection.
- When printing measurement value, input 3560 PRINT signal at timing after measurement is complete.
- When measurement value is printed using 9203 PRINT signal or Interval print function, use caution because measurement and printing may not synchronize and printing a previous measurement value may occur.
- Timing chart shows standard examples. It may very depending on users' application. When building line, etc, adjust waiting time and signal pulse width if operation error occurs or measurement value fluctuates.
- When building fastest line possible, first set parameter such as waiting time long and shorten each parameter as normal operation is confirmed.
- When line settings are proper and operation errors still occur, it may be the result of noise in the testing environment. Try the following solutions.
 - Install filter in the power supply 3560 and control equipment.
 - Use other power source for 3560 and control equipment. Isolate with transformer, etc.
 - Separate measurement leads, control signal and power supply line.
 - Shorten control signal and measurement lead's wire length.
 - Place control signal and measurement lead away from noise source such as control equipment.
 - Do not connect signal wire leads, etc to the unused terminal board.
 - When 3560 control equipment and other equipment are connected with control wires, separate control signal of other equipment and 3560 control signal.

6.3.4 Internal Circuit Configuration (Input/Output)

These respective charts illustrate the circuit configuration of the external control terminal (input) and the external output terminal (output). The external control terminal operates at the CMOS level.

Circuit configuration of the external control terminal

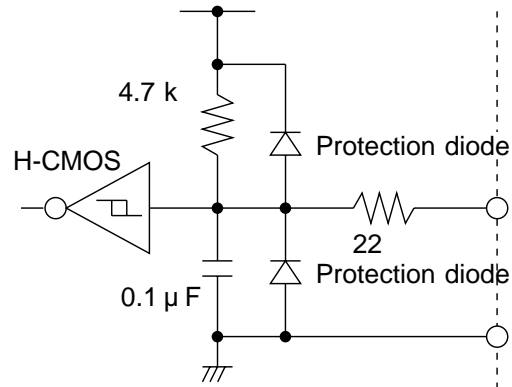

Circuit configuration of the external output terminal

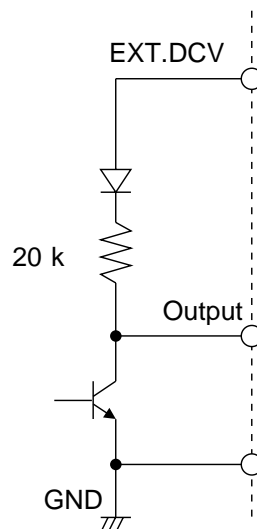

NOTE

Signal leads are functionally separate from measurement leads in order to prevent interaction between these lead groups. To preserve the insulation, be sure to ground the equipment if it's connected to the 3560.

Chapter 7

RS-232C Interface

Except for the power switch, all instrument functions can be performed by remote control through the RS-232C interface. The RS-232C and optional GP-IB interfaces may not be used simultaneously. (That is, only one interface may be used at any one given time.) For more information, see Section 7.2 "Operating Procedure (RS-232C)."

Specifications

Transmission mode	Start-stop synchronous, full duplex
Transfer rate	9600 bps (SPEED 9600 BPS)
Data bit length	8 bit (BIT 8)
Stop bit	1 bit (STOP 1)
Parity bit	None (PARITY NO)
Delimiter	CR+LF
Hand shake	Hardware
XON/XOFF	Not used (XON/XOFF OFF)
Connector	(D-sub9 Pin male #4-40 set square bolts) DESP-JB9P (Japan Avionics)

7.1 Connection to Computer (RS-232C)



WARNING

- To avoid electrocution, turn off the power to all devices before plugging or unplugging any of the interface connectors.
- To avoid damage to the instrument, do not short the output terminal and do not input voltage to the output terminal.

To connect the 3560 and a PC, attach one end of the RS-232C cable to the instrument's RS-232C connector and the other end to the PC serial port.

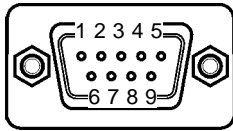

Rear panel of the instrument

Connector (D-sub) Pin number	Signal			Name
	RS-232C	CCITT	JIS	
1				Not used
2	BB(RxD)	104	RD	Data of reception
3	BA(TxD)	103	SD	Data of transmission
4	CD(DTR)	108/2	ER	Data terminal ready
5	AB(GND)	102	SG	Signal ground
6	CC(DSR)	107	DR	Not used
7	CA(RTS)	105	RS	Request for transmission
8	CB(CTS)	106	CS	Transmission ready
9				Not used

Usable cable conditions

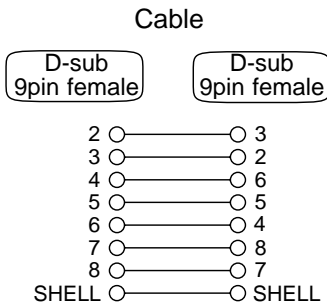

Connection: Reverse-type connection

The figure below gives a wiring diagram.

This particular example shows a connection to a PC/AT compatible.

Connecting to PC98 compatibles

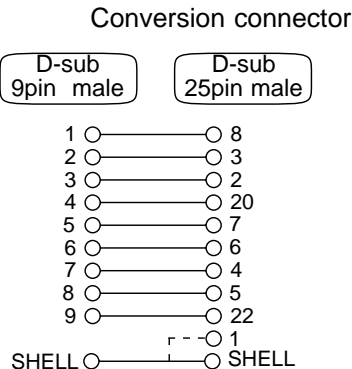
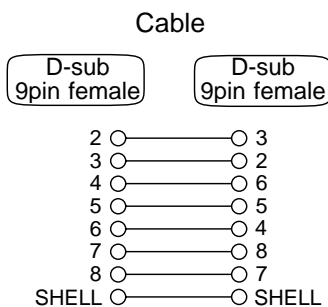

Use a 9-pin cable and 9/25 conversion pin connector to connect the 3560 to a PC98-series machine.

7.2 Operating Procedure (RS-232C)

7.2.1 Setting the RS-232C

Establishes communications. See the description below for hard flow.

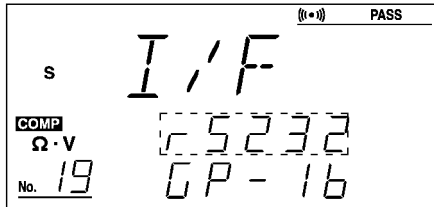

1. Press the **SHIFT** key. "SHIFT" appears lit on the display..
2. Press the **DOWN/INTERFACE** key.
3. Use the **+** and **-** keys to select RS-232C(*RS232*).
4. Press the **ENTER** key.
5. Use the **+** and **-** keys to turn hard flow on or off.
6. Press the **ENTER** key to return to the measurement screen.

Hard flow

Hard flow sets flow control (RTS/CTS) when data is transferred through the RS-232C interface. With hard flow enabled, data flow is controlled by the data transmission request signal (RTS) and transmission permit signal (CTS) between the 3560 and computer.

RTS: A PC outputs this signal to indicate readiness to receive data from a peripheral device.

CTS: A peripheral device outputs this signal to indicate readiness to receive data from the PC.

For information on setting flow control, refer to the operating manual for your PC. Make sure settings for the 3560 and the PC match.

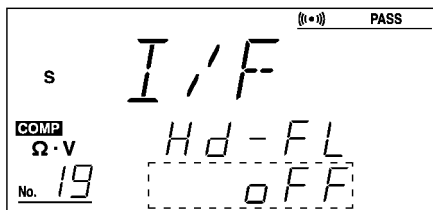

NOTE

If the 9588 GP-IB INTERFACE is not mounted, GP-IB cannot be selected.

7

7.2.2 Communication Methods by the RS-232C

In order to control the 3560 by the RS-232C, there are several kinds of messages. Of these, program messages are those received by the 3560 from the computer, while response messages are those sent from the 3560 to the computer.

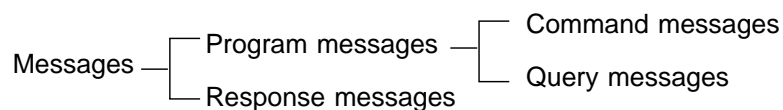

7.2.3 Program Messages

Program messages are command messages or query messages.

(1) Command messages

Command messages are orders for controls of the 3560, such as for making measurement condition settings or for reset or the like.

Example : LIM ON

(2) Query messages

Query messages are order for responses relating to results of measurement, or the state of 3560 settings. (A question mark "?" is suffixed at the end of the command.)

Example : CSET: BEEP?

7.2.4 Message Format

The commands for the 3560 are as far as possible mnemonic. Furthermore, all commands have a long form, and an abbreviated short form.

(1) Program message

The program message is made up from header and data portions.

Example : AUT ON

AUT: Header

ON: Data

(ASCII codes or numerical characters. Messages containing no data also exist in the form of query messages.)

A command header can be abbreviated. The whole command form is referred to as the "long form" and the abbreviated form as the "short form."

In this manual, the short form is written in upper case letters, and then this is continued in lower case letters so as to constitute the long form. Either of these forms will be accepted during operation, but intermediate forms will not be accepted. Further, during operation both lower case letters will be accepted without distinction.

(2) Response messages

It represents the response message for query messages from the 3560. Response messages generated by the 3560 are in long form and in upper case letters.

Example : CSET: BEEPER IN

NOTE

- If an error occurs when a query is received, no response message to the query is sent.
- When occurring in the message reference, the symbol " "(space) indicates a space.

7.2.5 Headers

(1) Program message headers

The program message always requires a header.

These are three types of header: simple headers, compound headers, and particular headers.

① Simple header

A header consisting of a single word beginning with a letter.

Example :AUTorange

② Compound header

A header consisting of a sequence of words separated by colons.

Example :LOCK:KEY

③ Particular header

A header beginning with an asterisk (*) to indicate that it is a particular command.

Example *CLS

7

(2) Response message

Headers in response message can be enabled or disabled by using the ":HEADer" command.

Example :CSET:BEEP? (Queries the buzzer setting)

Response: [If headers are ON] :CSET:BEEPER IN

Response: [If headers are OFF] IN (Data only)

7.2.6 Data Formats

The 3560 use character string data and decimal numeric data, and the type used varies according to the command in question.

(1) Character data

Character string data must always begin with an alphabetic character, and the characters following can be either alphabetic characters or numerals. Although in character data either upper case letters or lower case letters are accepted, response messages output by the 3560 are always in upper case letters.

Example :LIMIT ON

(2) Decimal data

The numeric data values are all represented in decimal, in three formats identified as NR1, NR2 and NR3, and each of these can appear as either a signed number or an unsigned number. Unsigned numbers are taken as positive.

Further, if the accuracy of a numerical value exceeds the limit which the 3560 can deal, it is rounded off. (5 and above is rounded up; 4 and below is rounded down)

①NR1 format - integer data.

Example +3000, -50000, 210

②NR2 format - fixed point numbers.

Example +2.56, -30.45, 300.28

③NR3 format - floating point numbers.

Example +3E-2, -1.2E3

The term "NRf format" includes all these three formats.

When the 3560 is receiving it accepts NRf format, but when it is sending response messages it utilizes whichever one of the formats NR1 to NR3 is indicated in the specified command.

Example :VRAN 5 :VRAN 5.01 :VRAN 0.05E2

7.2.7 Delimiters

The term "delimiter" is used to refer to the following two possibilities for separating data sequences.

The response message delimiter has the following two format:

CR + LF, CR, LF

The output is CR + LF.

7.2.8 Separators

(1) Message unit separator

A semicolon (;) is used as a message unit separator when it is desired to set out several messages on a single line.

When message are combined in this way, if a syntax error occurs, all subsequent messages up to the next delimiter will be ignored.

Example :RRAN 3E-2;:VRAN 50;:MEAS:BATT ?

(2) Header separator

In a message which has a header and data, a space (represented by "(space) in the examples) is used as the header separator to separate the header from the data.

Example :COMPARATOR 1

(3) Data separator

If a message has several data items, commas (,) are required as data separators for separating these data items from one another.

Example :CSET:RPAR *data1,data2*

7.2.9 Abbreviation of Compound Commands

When several compound headers have a common head portion (for example, :CSET:---), then, when and only when writing them directly following on from one another, this common portion (:CSET: in this example) can be omitted.

This common portion is called "the current path", by analogy with the general concept of the current directly in the directly structure of UNIX or MSDOS, and until it is cleared the analysis of following commands is performed by deeming them to be preceded by the current path is shown in the following example:

Normal expression

:CSET:NUMBer;:CSET:RPARameter

Abbreviated expression

:CSET:NUMBer;RPARameter

The current path is cleared when the power is turned on, when a colon (:) appears at the start of a command, and when delimiter is detected.

Messages with particular headers can be executed without relation to the current path. Further, they have no effect upon the current path.

While simple and complex command headers don't require a colon ":" prefix, we recommend using the colon to avoid confusion with abbreviated expressions and to prevent 3560 malfunction.

With the 3560, there are 3 possible current paths:
":CSET", ":LOCK", ":MEAS"

7.2.10 Output Buffer

The 3560 have an output buffer of 128 bytes capacity. Response messages accumulate in the output buffer and all data are received and cleared.

The output buffer is also cleared in the following four situations:

- ① When the instrument is powered on.
- ② When the Query error is occurred.
- ③ When the Device is cleared.
- ④ When the I/F is Switched.

7.2.11 Input Buffer

The 3560 have an input buffer of 128 bytes capacity. Switching the interface clears the current setting.

7.2.12 Status Byte Registers

(1) Status byte register (STB)

The status byte register is an 8-bit register whose contents are output from the 3560 to the controller, when serial polling is being performed. If even only one bit in the status byte register has changed from 0 to 1 (provided that it is a bit which has been set in the service request enable register as a bit which can be used), then the MSS bit is set to 1. Simultaneously with this the SRQ bit is set to 1, and service request is generated.

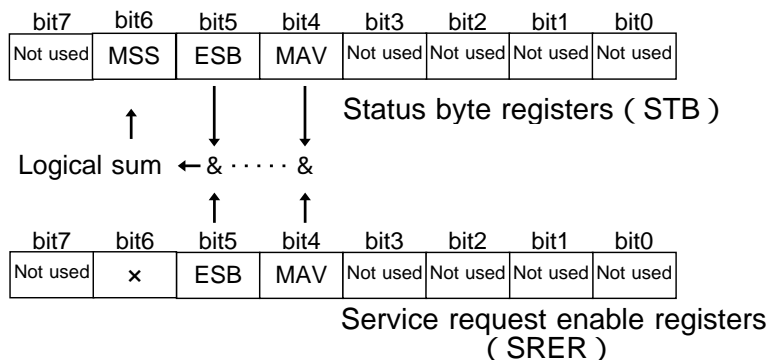

Although the MSS bit is read out on an *STB? query, on a *CLS command for example it is not cleared until the event is cleared.

Bit	Meaning
7	Not used
6 MSS	MSS shows the logical sum of other bits in the status byte register.
5 ESB	Standard event summary (logical sum) bit ESB shows the logical sum of the standard event status register.
4 MAV	Message available MAV indicates the output queue has messages.
3	Not used
2	Not used
1	Not used

(2) Service request enable register (SRER)

This register masks the status byte register. Setting a bit of this register to 1 enables the corresponding bit of the status byte register to be used.

7.2.13 Event Registers

(1) Standard event status register (SESR)

The standard event status register is an 8-bit register. If any bit in the standard event status register is set to 1 (after masking by the standard event status enable register), bit 5 (ESB) of the status byte register is set to 1.

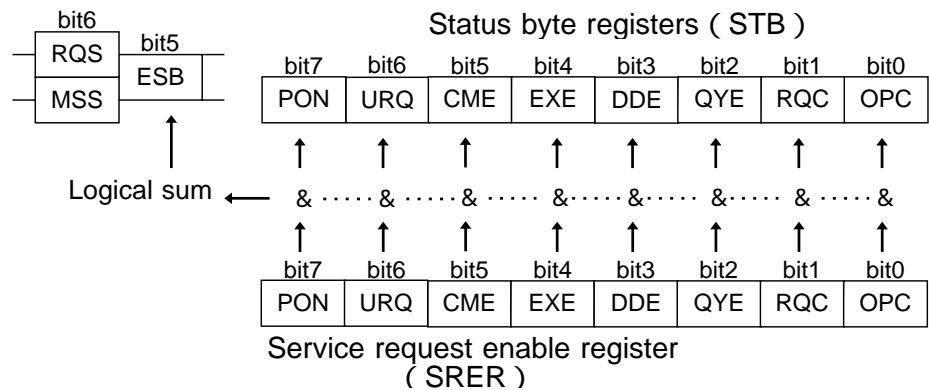

The standard event status register is cleared in the following four situations:

- ① When a *CLS command is received.
- ② When an *ESR? query is received.
- ③ When the instrument is powered on.
- ④ When the I/F is Switched.

(2) Standard event status enable register (SESER)

Setting any bit of the standard event status enable register to 1 enables the corresponding bit of the standard event status register to be accessed.

Standard event status register

Bit 7 PON	Power-on flag PON is set to "1" when the 3560 is turned on or restored from a power failure and switching the interface.
Bit 6 URQ	User request This bit is not used in the 3560.
Bit 5 CME	Command error (Commands up to the message terminator are ignored.) CME is set to "1" when the command received has the following syntax or interpretation errors: <ul style="list-style-type: none"> • A command not defined in the 3560 is received. • The program header is invalid. • The data quantity differs from the specified value. • The data format differs from that specified.
Bit 4 EXE	Execution error EXE is set to "1" when the command received cannot be executed because: <ul style="list-style-type: none"> • The specified data deviates from the specified range. • The specified data is not acceptable.
Bit 3 DDE	Error resulting from device malfunction. DDE is set to "1" if the command cannot be executed for any reason other than command, query, or execution errors. <ul style="list-style-type: none"> • The command cannot be executed, due to an error within the 3560. • The command cannot be executed, because another function is already active.
Bit 2 QYE	Query error (The output queue is cleared.) The query error is detected by the output queue controller and QYE set to "1" when the following events occur: <ul style="list-style-type: none"> • An attempt is made to read an empty output queue. • Deadlock state • The next message is received while the output queue contains data. • A query exists after the "*IDN?" query on the same line.
Bit 1 RQC	Controller privilege request This bit is not used in the 3560.
Bit 0 OPC	Operation complete OPC is set to "1" when (for example) the "*OPC" command executes: <ul style="list-style-type: none"> * When all actions specified by messages up to the "*OPC" command are complete

Register read/write command list

Register	Read	Write
Status byte register	*STB?	
Service request enable register	*SRE?	*SRE
Standard event status register	*ESR?	
Standard event status enable register	*ESE?	*ESE

NOTE

All adjustments made to the settings of the 3560 are stored in the internal EEPROM, for which the number of write operations is limited. When the EEPROM reaches the end of its life, the error message "ERR-3" appears. 3560 is turned off or data is not correctly written due to a faulty EEPROM while the measurement conditions are being set in the EEPROM of the 3560. Contact your dealer or Hioki representative.

7.3 Message Code Table

7.3.1 Common Command

Command	Input/output data format	Meaning
*CLS		Clears the status byte register and the event registers.
*ESE	Numerical value (1)	Sets the standard event status enable register.
*ESE?	NR1 (1)	Queries out and clears the contents of the standard event status register (SESR).
*ESR?	NR1 (1)	Queries out and clears the contents of the standard event status register (SESR).
IDN?	[HIOKI,3560,0,V.**]	Queries device ID.
*OPC		Sets the standard event status register bit0 (OPC bit) to "1."
*OPC?	NR1 (1)	Returns a "1" instead of setting the SESR bit0 (OPC bit) to "1."
*RST		Initializes the settings.
*SRE	Numerical value (1)	Sets the service request enable register (SRER).
*SRE?	NR1 (1)	Queries the service request enable register (SRER).
*STB?	NR1 (1)	Queries the status byte register.
*TRG		Request for sampling
*TST?	NR1 (1)	Requests execution of, and queries the result of, the self test.
*WAI		Waits until sampling is fully completed.

() indicates the number of data.

7.3.2 Messages

Command	Input/output Data format	Meaning
:ADJust?		Executes zero-adjust and queries the result.
:AUTorange	[ON/OFF] (1)	Sets the auto range.
:AUTorange?	[ON/OFF] (1)	Queries for auto-range mode on/off status.
:COMParator	Numerical value (1)	Selects the comparator to be used.
:COMParator?	NR1 (1)	Queries the comparator number.
:CSET:BEEPer	[OFF/IN/HI] (1) [OFF/PASS/FAIL] (1)	Sets the buzzer for comparator determination.
:CSET:BEEPer?	[OFF/IN/HI] (1) [OFF/PASS/FAIL] (1)	Queries the buzzer setting for comparator.
:CSET:MODE	[R/RV] (1)	Sets for the measurement mode set for the comparator.
:CSET:MODE?	[R/RV] (1)	Queries for the measurement mode set for the comparator.
:CSET:NUMBer	Numerical value (1)	Selects the number of comparator to be set.
:CSET:NUMBer?	NR1 (1)	Queries the number of comparator to be set.
:CSET:RPARameter	Numerical value (2)	Sets the upper and lower limits for comparator resistance.
:CSET:RPARameter?	NR3 (1)	Queries the upper and lower limits for comparator resistance.
:CSET:RRANge	Numerical value (1)	Sets the resistance range used by the comparator.
:CSET:RRANge?	NR3 (1)	Sets the resistance range used by the comparator.
:CSET:VPARameter	Numerical value (2)	Sets for the comparator voltage upper and lower limits.
:CSET:VPARameter?	NR3 (2)	Queries for the comparator voltage upper and lower limits.
:CSET:VRANge	Numerical value (1)	Sets for the voltage range used by the comparator.
:CSET:VRANge?	NR3 (1)	Queries for the voltage range used by the comparator.
:CTMode	[AUT/MAN]	Sets the comparator mode.
:CTMode?	[AUT/MAN]	Queries the comparator mode.
:FREQuency	Numerical value (1)	This command sets power supply voltage.
:FREQuency?	NR1 (1)	This command queries power supply voltage.
:HEADer	[ON/OFF] (1)	Enable and disable headers.
:HEADer?	[ON/OFF] (1)	Queries the headers enablement.
:HOLD	[ON/OFF] (1)	Sets the measurement hold.

:HOLD?	[ON/OFF] (1)	Queries for the hold-mode on/off status.
:LIMit	[ON/OFF] (1)	Queries for set open-circuit terminal voltage.
:LIMit?	[ON/OFF] (1)	Queries for set open-circuit terminal voltage.
:LOCK:EXTernal	[ON/OFF] (1)	This command turns external input terminal locking on or off.
:LOCK:EXTernal?	[ON/OFF] (1)	Response Format for Query that Returns Numeric Data
:LOCK:KEY	[ON/OFF] (1)	Sets the key lock.
:LOCK:KEY?	[ON/OFF] (1)	Queries for the on/off status of the key lock.
:MEASure:BATTery?	NR3 (2) [FAIL/PASS/OFF/NG] (1)	Queries for the current measured resistance and voltage and comparator result.
:MEASure:RESistance?	NR3 [HI/IN/LO/OFF/NG] or [FAIL/PASS/OFF/NG] (1)	Queries for the current measured resistance and comparator result.
:MEASure:VOLTage?	NR3	Queries for the current measured voltage and comparator result.
:MODE	[R/RV] (1)	Sets the measurement mode.
:MODE?	[R/RV] (1)	Queries the measurement mode.
:RRANge	Numerical value (1)	Sets the resistance range.
:RRANge?	NR3 (1)	Queries the resistance range.
:SAMPlE	[FAST/MED/SLOW] (1)	Sets the sampling rate.
:SAMPlE?	[FAST/MED/SLOW] (1)	Queries the sampling rate.
:SENSecheck	[ON/OFF] (1)	Sets the SENSE line break check for measurement leads.
:SENSecheck?	[ON/OFF] (1)	Queries on/off status of the SENSE line break check for measurement leads.
:VRANge	Numerical value (1)	Sets the voltage range.
:VRANge?	NR3 (1)	Queries the voltage range.
:ZERoclear		Excuses zero clear.

7.4 Message Reference

Example of command reference

: Command

Indicates functions of message reference

Syntax	Indicates the command syntax.	Function	Describes points that require special attention when using the command.
<i>data</i>	Indicates the data format for a command that includes data.	Notes	Indicates the what kinds of errors might occur.
Response syntax	Indicated only for commands for which a response message is returned.		
Example	Shows a simple example illustrating transmissions are indicated in "short form."		

NOTE

When occurring in the message reference, the symbol " "(space) indicates a space.

7.4.1 Common Command Messages

*CLS

Clears the status byte register and the event registers.

Syntax *CLS

Function This instruction clears the event registers and the bits of the status byte register associated with that register (SESR, STB).

Note This has no effect upon the output queue, the various enable registers, or bit 4 (the MAV bit) of the status byte register.

*ESE

Sets the standard event status enable register.

Syntax *ESE *data*

data 0 to 255 (Numerical value data)

Function This command sets the available patterns of the standard event status register (SESR) to the standard event status enable register (SESER).

Example
Transmission

*ESE 36

CME and QYE of the standard event status enable register are both set to "1."

Notes When the power is turned on, the data is reinitialized to 0.

bit7	bit6	bit5	bit4	bit3	bit2	bit1	bit0
PON	URQ	CME	EXE	DDE	QYE	RQC	OPC

Standard event status enable register (SESER)

*ESE?

Queries out and clears the contents of the standard event status register (SESR).

Syntax *ESE?

Function The contents of SESER are returned as a NR1 value (0 to 255).

Response syntax (If headers are ON)
*ESE *data*
(If headers are OFF)
data

Example (If headers are OFF)

Transmission *ESE?

Response 36

*ESR?

Queries out and clears the contents of the standard event status register (SESR).

Syntax	*ESR?	Function	This command returns the contents of the standard event status register (SESR) in NR1 numeric data format (<i>data</i>) (ranging from 0 to 255), then clears the register.
Response syntax	(If headers are ON) *ESR <i>data</i> (If headers are OFF) <i>data</i>		
Example	(If headers are OFF)		
Transmission	*ESR?		
Response	32		

*IDN?

Queries device ID.

Syntax	*IDN?	Function	Queries device ID (manufacturer's name, model name, software version).
Response syntax	HIOKI, 3560, 0, V2.00 First field Manufacturer's name Second field Model name Third field Serial number Fourth field Software version	Notes	<ul style="list-style-type: none"> • No header is affixed to the response message. • The *IDN? query is the last query message of the program messages. No further response is output.
Example	(If headers are ON)		
Transmission	*IDN?		
Response	IDN HIOKI , 3560 , 0 , V2 . 00		
	(If headers are OFF)		
Transmission	*IDN?		
Response	HIOKI , 3560 , 0 , V2 . 00		

*OPC

Sets the standard event status register bit0 (OPC bit) to "1."

Syntax	*OPC	Function	This command sets the standard event status register (SESR) bit0 (OPC bit) to "1" when all actions specified by messages and occurring before the *OPC command are complete.
Example	RST ; :MEAS:RES? ; *OPC		
Transmission	This command sets the specified bit to "1" when all *RST and MEAS actions are complete.		

*OPC?

Returns a "1" instead of setting the SESR bit0 (OPC bit) to "1."

Syntax	*OPC?	Function	The same as the *OPC command, except in that, at the instant that the previous commands have been completed, instead of bit 0 (the OPC bit) of the standard event status register (SESR) being set to 1, the response message "1" is returned.
Response syntax	(If headers are ON) *OPC? (If headers are OFF) 1		
Example <small>Transmission</small>	RST; :MEAS:RES?;*OPC? Returns a "1" when all *RST and MEAS actions are complete.		

*RST

Initializes the settings.

Syntax	*RST	Function	<ul style="list-style-type: none"> • Resets the 3560 instrument. • The table below lists contents to be reset.
---------------	------	-----------------	--

Initialized items by the 3560			
Measurement mode	Resistance measurement mode	Comparator number	1
Resistance measurement range	Auto range	voltage limiter	ON
Sampling rate	SLOW	Broken SENSE line detector	OFF
Hold	Free run	Comparator mode	AUTO
Comparator	OFF	Power supply frequency	50 Hz

Initialized items by the RS-232C or GP-IB	
Header	ON
Comparator number to be set by the "CSET" message	1

Uneffected contents
Status byte register
Standard event status register
Enable registers.
Interface function
GP-IB address
Output queue
Input buffer
Current pass

***SRE**

Sets the service request enable register (SRER).

Syntax	*SRE <i>data</i>	Function	This command sets the available patterns of the service request enable register (SRER) to the status byte register (STB).
	<i>data</i> 0 to 255		
Example Transmission	*SRE 32	Notes	When 3560 is turned on or I/F is switched, the data is reset to "0."
	Explanation of example: the service request enable register ESB is set to "1."		

***SRE?**

Queries the service request enable register (SRER).

Syntax	*SRE?	Function	Returns the value of the service request enable register (SRER) set by the *SRE command as a numerical data value in NR1 format taken from the set: 0 to 255.
Response syntax	(If headers are ON) SRE <i>data</i> (If headers are OFF) <i>data</i>		
Example Transmission Response	*SRE? 32		

***STB?**

Queries the status byte register.

Syntax	*STB?	Function	Returns the set contents of the status byte register (STB) as a numerical data value in NR1 format (0,16,32,48).
Response syntax	(If headers are ON) *STB <i>data</i> (If headers are OFF) <i>data</i>	Notes	The value in the MSS bit represents bit6. The MSS bit remains uncleared, even if the service request is cleared by the serial poll.
Example Transmission Response	(If headers are ON) *STB? 32		
	An event occurs in the standard event status register.		

***TRG**

Request for sampling

Syntax	*TRG	Function	This command executes one sampling cycle while the 3560 is in hold mode.
Example Transmission Response	HOLD_ON; :MEAS:RES?; *TRG; :MEAS:RES? 20.345E-3, OFF, 21.567E-3, OFF		

***TST?**

Requests execution of, and queries the result of, the self test.

Syntax TST?

Response syntax (If headers are ON)
TST *data*
(If headers are OFF)
data

Example
Transmission
Response

TST?

2

RAM error

Function

- Causes the 3560 to perform the self test, and returns the result thereof as a numerical data value in NR1 format (0 to 7).
- The results are shown below. When each bit is set to "1," an associated error has occurred.

bit7	bit6	bit5	bit4	bit3	bit2	bit1	bit0
Not used	Not used	Not used	Not used	Not used	EEPROM	RAM	ROM

***WAI**

Waits until sampling is fully completed.

Syntax *WAI

Function The next command executes after the command now executing.

7.4.2 Specific Command Messages

:ADJust?

Executes zero-adjust and queries the result.

<p>Syntax :ADJust?</p> <p>Response syntax (If headers are ON) :ADJUST <i>data</i> (If headers are OFF) <i>data</i></p> <p>Example (If headers are ON) Transmission :ADJ? Response :ADJUST 0</p> <p>(If headers are OFF) Transmission :ADJ? Response 0</p> <p>The zero-adjust executes successfully.</p>	<p>Function This command executes a zero-adjust and returns a result in 0/1 NR1 numeric data (<i>data</i>) format. If "<i>data</i> = 0," the zero-adjust executes correctly. If "<i>data</i> = 1," the zero-adjust does not execute correctly.</p> <p>Notes The zero-adjust cannot be performed in the following cases: A zero-adjust is attempted when the following parameters exceed the specified limits: Resistance function 240 dgt. (FAST mode) 2400 dgt. (MEDIUM/SLOW mode) Voltage function 3400 dgt. (full sampling) Abnormal measurements</p>
--	--

:AUTOrange

Sets the auto range.

<p>Syntax :AUTOrange_ <i>data</i></p> <p><i>data</i> ON/OFF (Character data)</p> <p>Example :AUTO ON Transmission</p> <p>The measurement is performed in auto-range mode.</p>	<p>Function This command turns auto range on or off.</p> <p>Notes Setting only resistance range or only voltage range is not permitted.</p>
---	---

:AUTOrange?

Queries for auto-range mode on/off status.

Syntax	:AUTOrange?	Function	This command returns the current auto range setting in ON/OFF character data (<i>data</i>) format.
Response syntax	(If headers are ON) :AUTORANGE <i>data</i> (If headers are OFF) <i>data</i>		
Example	(If headers are ON)		
Transmission	:AUT?		
Response	:AUTORANGE OFF? (If headers are OFF)		
Transmission	:AUT?		
Response	OFF		

:COMParator

Selects the comparator to be used.

Syntax	:COMParator <i>data</i> <i>data</i>	Function	This command sets the comparator number to be used as follows. If " <i>data</i> = 0, " the comparator is turned off. If " <i>data</i> = 1 to 30, " the comparator with the specified number is used. The comparator is turned on.
Example	:COMP 1		
Transmission	Comparator 1 is used.	Notes	If the specified comparator number falls outside the valid range, an execution error occurs.

:COMParator?

Queries the comparator number.

Syntax	:COMParator?	Function	This command returns the current comparator number in NR1 numeric data (<i>data</i>) ranging from 0 to 30. The numbers returned indicate the following states: If " <i>data</i> = 0, " the comparator is turned off. If " <i>data</i> = 1 to 30, " the comparator with the number specified in <i>data</i> is used.
Response syntax	(If headers are ON) :COMPARATOR <i>data</i> (If headers are OFF) <i>data</i>		
Example	(If headers are ON)		
Transmission	:COMP?		
Response	:COMPARATOR 1 (If headers are OFF)		
Transmission	:COMP?		
Response	1 Comparator 1 is currently used.		

:CSET:BEEPer

Sets the buzzer for comparator determination.

Syntax	:CSET:BEEPer <i>data</i>	Function	This command sets the buzzer for the comparator specified by the :CSET:NUMBer command.
<i>data</i>	Resistance measurement mode: OFF/IN/HL character data Resistance and voltage measurement mode: OFF/PASS/FAIL character data	Notes	Data is selected according to the mode specified by the :CSET:MODE command. Two modes are available: resistance measurement mode and resistance and voltage measurement mode.
Example Transmission	:CSET:BEEP IN The setting is made so that the buzzer sounds when the comparator result is IN.		

:CSET:BEEPer?

Queries the buzzer setting for comparator.

Syntax	:CSET:BEEPer?	Function	This command returns the buzzer setting for the comparator specified by the :CSET:NUMBer command in OFF/IN/HL character data format (resistance measurement mode) or OFF/PASS/FAIL character data format (resistance and voltage measurement mode). The data format is <i>data</i> .
Response syntax	(If headers are ON) :CSET:BEEPER <i>data</i> (If headers are OFF) <i>data</i>		
Example Transmission	(If headers are ON) :CSET:BEEP?		
Response	:CSET:BEEPER IN (If headers are OFF) :CSET:BEEP?		
Transmission	:CSET:BEEP?		
Response	IN A setting is made so that the buzzer for the specified comparator number sounds when the comparator result is IN.		

:CSET:MODE

Sets for the measurement mode set for the comparator.

Syntax	:CSET:MODE <i>data</i>	Function	This command selects either resistance measurement mode or resistance and voltage measurement mode for the comparator specified by the :CSET:NUMBer command.
<i>data</i>	R/RV (Character data)		
Example Transmission	CSET:NUMB 10;MODE R Comparator number 10 is set to resistance measurement mode.	Notes	If character data other than R or RV is set, an execution error occurs.

:CSET:MODE?

Queries for the measurement mode set for the comparator.

Syntax	:CSET:MODE?	Function	This command selects resistance measurement mode or resistance and voltage measurement mode for the comparator specified by the :CSET:NUMBER command.
Response syntax	(If headers are ON) :CSET:MODE <i>data</i> (If headers are OFF) <i>data</i>		
Example	(If headers are ON)		
Transmission	:CSET:NUMB 20;MOD?		
Response	:CSET:MODE RV		
	(If headers are OFF)		
Transmission	:CSET:NUMB 20;MOD?		
Response	RV		

:CSET:NUMBER

Selects the number of comparator to be set.

Syntax	:CSET:NUMBER <i>data</i>	Function	This command is used to select the number of comparator to be set.
	<i>data</i> 1 to 30 (Numerical value data)	Notes	If the set numeric data falls outside the range 1 to 30, an execution error occurs.
Example	:CSET:NUMBER 1		
Transmission	Comparator 1 is set.		

:CSET:NUMBER?

Queries the number of comparator to be set.

Syntax	:CSET:NUMBER?	Function	This command returns the currently set comparator number as a NR1 value (1 to 30).
Response syntax	(If headers are ON) :CSET:NUMBER <i>data</i> (If headers are OFF) <i>data</i>		
Example	(If headers are ON)		
Transmission	:CSET:NUMB?		
Response	:CSET:NUMBER 1		
	(If headers are OFF)		
Transmission	:CSET:NUMB?		
Response	1		

:CSET:RPARAmeter

Sets the upper and lower limits for comparator resistance.

Syntax :CSET:RPARAmeter *data1*, *data2*
data

Range ()	<i>data1</i>	<i>data2</i>
30 m	0 to 31.000E-3	0 to 31.000E-3
300 m	0 to 310.00E-3	0 to 310.00E-3
3	0 to 3.1000	0 to 3.1000
30	0 to 31.000	0 to 31.000
300	0 to 310.00	0 to 310.00
3 k	0 to 3.1000E+3	0 to 3.1000E+3

*Numerical value data

Example
Transmission :CSET:RRAN 30E-3;:RPAR 10.123E-3, 25.567E-3

The comparator function executes in the 30 m range under the conditions: the upper limit is 25.567 m and the lower limit is 10.123 m .

Function This command sets the resistance range of the comparator specified by the :CSET:NUMBER command. The upper and lower limits are determined automatically; the smaller value is defined as the lower limit and the larger value is defined as the upper limit.

Notes If the set range deviates from the range specified by the :CSET:RRANGE command, an execution error occurs.

:CSET:RPARAmeter?

Queries the upper and lower limits for comparator resistance.

Syntax :CSET:RPARAmeter?

Response syntax (If headers are ON)
:CSET:RPARAMETER *data1*, *data2*
(If headers are OFF)
data1, *data2*

Example (If headers are ON)
Transmission :CSET:RPAR?
Response :CSET:RPARAMETER 25.567E-3, 10.123E-3

(If headers are OFF)

Transmission :CSET:RPAR?
Response 25.567E-3, 10.123E-3

Function This command returns the set resistance range of the comparator specified by the :CSET:NUMBER command in NR3 numeric data (*data*) format.

:CSET:RRANge

Sets the resistance range used by the comparator.

Syntax :CSET:RRANge *data*

data 0.03,0.3,3,30,300,3000
(Numerical value data)

Example
Transmission :CSET:RRAN 0.03

The 30 m range is selected in the comparator setting.

Function This command sets the resistance range for the comparator specified by the :CSET:NUMBER command.

Notes If numeric data is not specified, an execution error occurs.

:CSET:RRANge?

Sets the resistance range used by the comparator.

Syntax :CSET:RRANge?

Response syntax (If headers are ON)
:CSET:RRANGE *data*
(If headers are OFF)
data

Example (If headers are ON)
Transmission :CSET:RRAN?
Response :CSET:RRANGE 0.03

(If headers are OFF)
Transmission :CSET:RRAN?
Response 0.03

Function This command returns the set resistance range of the comparator specified by the :CSET:NUMBER command in NR3 numeric data (*data*) format

Range ()	data
30m	30E-3
300m	300E-3
3	3E+0
30	30E+0
300	300E+0
3k	3E+3

:CSET:VParAmeter

Sets for the comparator voltage upper and lower limits.

Syntax :CSET:VParAmeter *data1, data2*
data

Range (V)	data1	data1
5	-5.0000 to 5.0000	-5.0000 to 5.0000
50	-50.000 to 50.000	-50.000 to 50.000

*Numerical value data

Example
Transmission :CSET:VRAN 5;:VPar 0.5000,3.5000
The comparator function executes in the 5 V range under these conditions: the upper limit is 3.5 V and the lower limit is 0.5 V.

Function This command sets the voltage range of the comparator specified by the :CSET:NUMBER command. The upper and lower limits are determined automatically; the smaller value is defined as the lower limit and the larger value is defined as the upper limit.

- Notes**
- If the set range deviates from the range specified by the :CSET:VRANge command, an execution error occurs.
 - If resistance measurement mode has been selected by the :CSET:MODE command for the comparator specified by the :CSET:NUMBER command, an execution error occurs.

:CSET:VParAmeter?

Queries for the comparator voltage upper and lower limits.

Syntax :CSET:VParAmeter?

Response syntax (If headers are ON)
:CSET:VPARAMETER *data1, data2*
(If headers are OFF)
data1, data2

Example (If headers are ON)
Transmission :CSET:VPar?
Response :CSET:RPARAMETER 3.5000E+0,0.5000E+0
(If headers are OFF)
Transmission :CSET:VPar?
Response 3.5000E+0,0.5000E+0

Function This command returns the set voltage range of the comparator specified by the :CSET:NUMBER command in NR3 numeric data (*data*) format.

- Notes**
- If resistance measurement mode has been selected by the :CSET:MODE command for the comparator specified by the :CSET:NUMBER command, an execution error occurs.

:CSET:VRANge

Sets for the voltage range used by the comparator.

<p>Syntax :CSET:VRANge <i>data</i></p> <p><i>data</i> -50 to 50 (Numerical value data)</p>	<p>Function This command sets the voltage range of the comparator specified by the :CSET:NUMBER command.</p>
<p>Example Transmission :CSET:VRAN 5</p> <p>The 5 V range is selected in the comparator setting.</p>	<p>Notes</p> <ul style="list-style-type: none"> • If numeric data is not specified, an execution error occurs. • If resistance measurement mode has been selected by the :CSET:MODE command for the comparator specified by the :CSET:NUMBER command, an execution error occurs.

:CSET:VRANge?

Queries for the voltage range used by the comparator.

<p>Syntax :CSET:VRANge?</p>	<p>Function This command returns the set voltage range of the comparator specified by the :CSET:NUMBER command in NR3 numeric data (<i>data</i>) format.</p> <p>5 V range 5E+0 50 V range 50E+0</p>
<p>Response syntax (If headers are ON) :CSET:VRANge <i>data</i> (If headers are OFF) <i>data</i></p>	<p>Notes If resistance measurement mode has been selected by the :CSET:MODE command for the comparator specified by the :CSET:NUMBER command, an execution error occurs.</p>
<p>Example (If headers are ON)</p> <p>Transmission :CSET:VRAN?</p> <p>Response :CSET:VRANge 5E+0</p> <p>(If headers are OFF)</p> <p>Transmission :CSET:VRAN?</p> <p>Response 5E+0</p>	

:CTMode

Sets the comparator mode.

<p>Syntax :CTMode <i>data</i></p> <p><i>data</i> AUTO/MANUal (Character data)</p>	<p>Function This command sets comparator mode to either of auto-comparator mode or manual comparator mode.</p>
<p>Example Transmission :CTM AUT</p> <p>The external control terminal mode is set to AUTO.</p>	

:CTMode?

Queries the comparator mode.

Syntax	:CTMode?	Function	This command returns the set comparator mode in AUTO/MANUAL character data (data) format.
Response syntax	(If headers are ON) :CTMODE <i>data</i> (If headers are OFF) <i>data</i>		
Example	(If headers are ON)		
Transmission	:CTM?		
Response	:CTMODE AUTO?		
	(If headers are OFF)		
Transmission	:CTM?		
Response	AUTO		

:FREQUENCY

This command sets power supply voltage.

Syntax	:FREQuenc <i>data</i>	Function	Sets power supply voltage.
	<i>data</i> 50/60 (Numerical value data)	Notes	When the power supply frequency data is not 50 Hz or 60 Hz, this command rounds it off to 50 Hz or 60 Hz.
Example	:FREQ 50		
Transmission	Power supply voltage is set to 50Hz.		

:FREQUENCY?

This command queries power supply voltage.

Syntax	:FREQUENCY?	Function	This command returns the current power supply voltage setting in 50/60 numeric data (data) format.
Response syntax	(If headers are ON) :FREQUENCY <i>data</i> (If headers are OFF) <i>data</i>		
Example	(If headers are ON)		
Transmission	:FREQ?		
Response	:FREQUENCY 50		
	(If headers are OFF)		
Transmission	:FREQ?		
Response	50		

:HEADer

Enable and disable headers.

Syntax	HEADer <i>data</i>	Function	This command turns response message header on or off.
	<i>data</i> ON/OFF (Character data)		
Example Transmission	HEAD OFF		
	No header is affixed to the response message.		

:HEADer?

Queries the headers enablement.

Syntax	:HEADer?	Function	This command returns the response message header setting in ON/OFF character data (<i>data</i>) format.
Response syntax	(If headers are ON) :HEADER ON (If headers are OFF) OFF		
Example Transmission	(If headers are ON) :HEAD?		
Response	:HEADER ON		
	(If headers are OFF)		
Transmission	:HEAD?		
Response	OFF		

:HOLD

Sets the measurement hold.

Syntax	:HOLD <i>data</i>	Function	This command turns measurement hold on or off.
	<i>data</i> ON/OFF (Character data)		
Example Transmission	:HOLD ON	Notes	When the measurement mode is changed in the hold status, the displayed voltage may not be output to the RS-232C and GP-IB, or irrelevant values may be displayed on the screen. After the measurement mode is changed, measure the waveforms again.
	The measured value can be held.		

:HOLD?

Queries for the hold-mode on/off status.

Syntax	:HOLD?	Function	This command returns the current measurement hold setting in ON/OFF character data (<i>data</i>) format.
Response syntax	(If headers are ON) :HOLD <i>data</i> (If headers are OFF) <i>data</i>		
Example	(If headers are ON)		
Transmission	:HOLD?		
Response	:HOLD ON		
	(If headers are OFF)		
Transmission	:HOLD?		
Response	ON		

:LIMit

Queries for set open-circuit terminal voltage.

Syntax	:LIMit <i>data</i>	Function	This command turns open-circuit terminal voltage on or off.
	<i>data</i> ON/OFF (Character data)		
Example	:LIM ON		
Transmission	Limiter is set to ON.		

:LIMit?

Queries for set open-circuit terminal voltage.

Syntax	:LIMit?	Function	This command returns the setting for open-circuit terminal voltage in ON/OFF character data (<i>data</i>) format.
Response syntax	(If headers are ON) :LIMI <i>data</i> (If headers are OFF)		
Example	(If headers are ON)		
Transmission	:LIM?		
Response	:LIMIT ON		
	(If headers are OFF)		
Transmission	:LIM?		
Response	ON		

:LOCK:EXternal

This command turns external input terminal locking on or off.

Syntax :LOCK:EXternal *data*
data ON/OFF (Character data) **Function** External input terminal locking turns on or off.

Example
 Transmission :LOCK:EXT ON
 External input terminal locking is turned on..

:LOCK:EXternal?

Response Format for Query that Returns Numeric Data

Syntax :LOCK:EXternal?
Response syntax (If headers are ON)
 :LOCK:EXTERNAL *data*
 (If headers are OFF)
data **Function** This command returns the current external input terminal lock setting in ON/OFF character data (*data*) format.

Example (If headers are ON)
 Transmission :LOCK:EXT?
 Response :LOCK:EXTERNAL ON
 (If headers are OFF)
 Transmission :LOCK:EXT?
 Response ON

:LOCK:KEY

Sets the key lock.

Syntax :LOCK:KEY *data*
data ON/OFF (Character data) **Function** This command turns key lock ON or OFF.

Example
 Transmission :LOCK:KEY ON
 Key lock is turned on.

:LOCK:KEY?

Queries for the on/off status of the key lock.

Syntax	:LOCK:KEY?	Function	This command returns the current key lock setting in ON/OFF character data (<i>data</i>) format.
Response syntax	(If headers are ON) :LOCK:KEY <i>data</i> (If headers are OFF) <i>data</i>		
Example	(If headers are ON)		
Transmission	:LOCK:KEY?		
Response	:LOCK:KEY ON		
	(If headers are OFF)		
Transmission	:LOCK:KEY?		
Response	ON		

:MEASure:BATTery?

Queries for the current measured resistance and voltage and comparator result.

Syntax :MEASure:BATTery?

Response syntax (If headers are ON)
:MEASURE:BATTERY *data1*, *data2*
(If headers are OFF)
data1, *data2*

data1 Resistance

Resistance range ()	Sampling rate	
	FAST	MEDIUM/SLOW
30 m	. E-3	. E-3
300 m	. E-3	. E-3
3	. E+0	. E+0
30	. E+0	. E+0
300	. E+0	. E+0
3 k	. E+3	. E+3
OFF	1.0000E+8	1.0000E+8
NG	1.0000E+9	1.0000E+9

data2 Voltage

Voltage range (V)	All of sampling rate
5	± . E+0
50	± . E+0
OFF	± 1.0000E+8
NG	1.0000E+9

data3 FAIL/PASS comparator results
OFF comparator isnot used
NG Abnormal measurements

Example (If headers are ON)

Transmission :MEAS:BATT?
Response :MEASURE:BATTERY 20.123E-3,
3.5678E+0,PASS

(If headers are OFF)

Transmission :MEAS:BATT?
Response 20.123E-3,3.5678E+0,PASS

Function • In resistance and voltage measurement mode, this command returns current measured resistance and voltage in NR3 numeric data format (*data1* and *data2*) and the comparator result in FAIL/PASS/OFF/NG character data format (*data3*).

Notes If resistance measurement mode is active, an execution error occurs.

:MEASure:RESistance?

Queries for the current measured resistance and comparator result.

Syntax :MEASure:RESistance?

Response syntax (If headers are ON)
:MEASURE:RESISTANCE *data1*, *data2*
(If headers are OFF)
data1, *data2*
HI/IN/LO/FAIL/PASS comparator results
OFF Comparator is not used.
NG Abnormal measurements

Function

- This command returns the current measured resistance in NR3 numeric data format (*data1*), and the comparator result in HI/IN/LO/OFF/NG character data format (*data2*) or FAIL/PASS/OFF/NG character data format (*data2*).
- HI/IN/LO is returned in voltage measurement mode, while FAIL/PASS is returned in resistance and voltage measurement mode.

data1 Resistance

Resistance range ()	Sampling rate	
	FAST	MEDIUM/SLOW
30 m	. E-3	. E-3
300 m	. E-3	. E-3
3	. E+0	. E+0
30	. E+0	. E+0
300	. E+0	. E+0
3 k	. E+3	. E+3
OFF	1.0000E+8	1.0000E+8
NG	1.0000E+9	1.0000E+9

data2 HI/IN/LO/FAIL/PASS comparator results
OFF Comparator is not used.
NG Abnormal measurements

Example (If headers are ON)

Transmission :MEAS:RES?

Response :MEASURE:RESISTANCE 20.123E-3, IN

(If headers are OFF)

Transmission :MEAS:RES?

Response 20.123E-3, IN

:MEASure:VOLTage?

Queries for the current measured voltage and comparator result.

Syntax :MEASure:VOLTage?

Response syntax (If headers are ON)
:MEASURE:VOLTAGE *data1,data2*
(If headers are OFF)
data1,data2

data1

Voltage range (V)	All of sampling rate
5	± . E+0
50	± . E+0
OFF	± 1.0000E+8
NG	1.0000E+9

Function • This command returns the current measured voltage in NR3 numeric data format (*data1*), and the comparator result in HI/IN/LO/OFF/NG character data format (*data2*) or FAIL/PASS/OFF/NG character data format (*data2*).

Notes If resistance measurement mode is active, an execution error occurs.

data2

FAIL/PASS comparator results
OFF Comparator is not used.
NG Abnormal measurements

Example (If headers are ON)
Transmission :MEAS:VOLT?
Response :MEASURE:VOLTAGE 3.5678E+0,FAIL

(If headers are OFF)
Transmission :MEAS:VOLT?
Response 3.5678E+0,FAIL

:MODE

Sets the measurement mode.

Syntax :MODE *data*

data R/RV (Character data)

Function Sets the measurement mode.

Example
Transmission :MOD RV
Measurement mode is set to resistance and voltage measurement mode.

:MODE?

Queries the measurement mode.

Syntax	:MODE?	Function	This command returns the current measurement mode setting in R/RV numeric data (<i>data</i>) format.
Response syntax	(If headers are ON) MODE <i>data</i> (If headers are OFF) <i>data</i>		
Example	(If headers are ON)		
Transmission	:MOD?		
Response	:MODE R		
	(If headers are OFF)		
Transmission	:MOD?		
Response	R		
	Sets resistance measurement mode.		

:RRANge

Sets the resistance range.

Syntax	:RRANge <i>data</i>	Function	Sets the resistance range.
<i>data</i>	0 to 3.1E+3 (Numerical value data)	Notes	• If another range is set, an execution error occurs.
Example	:RES:RANG 3000		
Transmission	Resistance range is set to 3 k range.		

Range ()	data
30 m	30E-3
300 m	300E-3
3	3E+0
30	30E+0
300	300E+0
3 k	3E+3

:RRANge?

Queries the resistance range.

Syntax	:RRANge?	Function	This command returns the currently set resistance range in NR3 numeric data (<i>data</i>) format.
Response syntax	(If headers are ON) :RRANGE <i>data</i> (If headers are OFF) <i>data</i>	Notes	If auto range is active, returns the currently set range.
Example	(If headers are ON)		
Transmission	:RRAN?		
Response	:RRANGE 300E0		
	(If headers are OFF)		
Transmission	:RRAN?		
Response	300E0		

:SAMPlE

Sets the sampling rate.

Syntax	:SAMPlE <i>data</i>	Function	Sets the sampling rate.
	<i>data</i> FAST/MEDIUM/SLOW (Character data)		
Example	:SAMP FAST		
Transmission			The sampling rate is set to FAST.

:SAMPlE?

Queries the sampling rate.

Syntax	:SAMPlE?	Function	This command returns the current sampling rate setting in FAST/MEDIUM/SLOW character data (<i>data</i>) format.
Response syntax	(If headers are ON) :SAMPlE <i>data</i> (If headers are OFF) <i>data</i>		
Example	(If headers are ON)		
Transmission	:SAMP?		
Response	:SAMPLE SLOW		
	(If headers are OFF)		
Transmission	:SAMP?		
Response	SLOW		

:SENSecheck

Sets the SENSE line break check for measurement leads.

Syntax :SENSecheck *data* **Function** SENSE line break check for measurement leads turns on or off.
data ON/OFF (Character data)

Example :SENS ON
 Transmission
 Broken-line detection is turned on for the SENSE line of the measurement leads.

:SENSecheck?

Queries on/off status of the SENSE line break check for measurement leads.

Syntax :SENSecheck? **Function** This command returns the setting for SENSE line break check for measurement leads in ON/OFF character data (*data*) format.
Response syntax (If headers are ON)
 :SENSECHECK *data*
 (If headers are OFF)
data

Example (If headers are ON)
 Transmission :SENS?
 Response :SENSECHECK ON
 (If headers are OFF)
 Transmission :SENS?
 Response ON

:VRANge

Sets the voltage range.

Syntax :VRANge *data* **Function** Sets the voltage range.
data -50 to 50 (Numerical value data) **Notes** • If another range is set, an execution error occurs.
 • If resistance measurement mode is active, an execution error occurs.

Example :VRAN 5
 Transmission
 Voltage range is set to 5 V range.

:VRANge?

Queries the voltage range.

Syntax :VRANge?

Response syntax (If headers are ON)
:VRANGE *data*
(If headers are OFF)
data

Example (If headers are ON)

Transmission :VRAN?

Response :VRANGE 50E+0

(If headers are OFF)

Transmission :VRAN?

Response 50E+0

Function This command returns the currently set voltage range in NR3 numeric data (*data*) format.

- Notes**
- If resistance measurement mode is active, an execution error occurs.
 - If auto range is active, returns the currently set range.

:ZERoclear

Excuses zero clear.

Syntax :ZERoclear

Example (If headers are ON)

Transmission :ZER

The zero-clear is executed.

Function Zero-clear is a function used to return the zero-adjust data to their default values.

7.5 Initialize Item List

Item \ Initialization method	After power-on	*RST command	*CLS command
RS-232C communication conditions	—	—	—
Device-specific functions (range, etc.)	—		—
Output queue		—	—
Input buffer		—	—
Event resister		—	
Current pass		—	—
Header on/off		—	—

7.6 Notes on RS-232C Interface

Symptom	Cause/Treatment
The RS-232C has stopped working completely.	Are the cables properly connected?
	Are all the devices powered on?
	Has the communication condition been correctly set?
Transmission on the RS-232C is not taking place properly.	Is the controller delimiter set correctly? (Refer to Section 7.2.7, "Delimiters".)
When attempting to read data using a BASIC INPUT statement, the RS-232C bus hangs.	Be sure to transmit one query before each INPUT statement.
	Have any of these transmitted queries resulted in an error?
Although a command has been transmitted, nothing has happened.	Using the *ESR? query, inspect the standard event status register, and check what type of error has occurred.
	Using the ERRor? query, and check whether transmission error occurred on the RS-232C.
The amount of data read in is insufficient.	If the data includes one or more commas, then try using a LINE INPUT statement.
Sending several queries, produces only one response.	Has an error occurred?
	Send the queries one at a time, and read the responses individually. When you want to read them in all at once, try doing so by putting them all on one line separated by the message separator character.
	Have *IDN? query been used?
The response message to a query differs from the display on the front panel of the 3560.	Due to the response message being produced at the instant that the 3193 receives the query, there is a possibility that it may not agree with the display at the instant that the controller reads it in.

Chapter 8

GP-IB Interface (Option)

Except for the power switch, all instrument functions can be performed by remote control through the optional GP-IB interface. The RS-232C and optional GP-IB interfaces may not be used simultaneously. (That is, only one interface may be used at any one given time.) For more information on selecting between the RS-232C or GP-IB interface, see the section that describes setting the RS-232C interface. For more information on selecting between the RS-232C or GP-IB interface, see the section that describes Section 8.2 "Operating Procedure (GP-IB)." For more information on mounting the 9588 GP-IB interface, see Chapter 4 "Measurement Procedure."

Applicable standard: IEEE-488.1 1987

Reference standard: IEEE-488.2 1987

If the output queue is full, the 9588 issues a query error to clear it. The 9588 does not support output queue clear and query error output functions in the deadlock state, as defined in the IEEE-488.2 standard. (Deadlock state: Both input buffer and output queue are full, halting further data processing.)

Connector

Use a 24-pin connector compatible with the IEEE-488 bus. Multiple standard bus cables may be used.

Interface function

See the interface function table.

Applicable code: ASCII code

SH1	All source handshake functions
AH1	All accepter handshake functions
T6	Basic talk functions Serial poll function Talk-only mode is not provided. The talker cancellation function with MLA (My Listen Address) is provided.
L4	Basic listener function Listen-only mode is not provided. The listener cancellation function with MTA (My Talk Address) is provided.
SR1	All service request functions
RL1	All remote/local functions
PP0	Parallel polling is not provided.
DC1	All device clear functions
DT1	All device trigger functions
C0	The controller function is not provided.

8.1 Connection to Computer (GP-IB)

⚠ WARNING

- To avoid electrocution, turn off the power to all devices before plugging or unplugging any of the interface connectors.
- To avoid damage to the interface, do not short the output terminal and do not input voltage to the output terminal. When the instrument is removed, place a blank panel over the opening. This keeps the instrument's internal temperature uniform and within specifications.

To connect the 3560 to a PC, connect the GP-IB cable to the instrument's GP-IB connector and the PC serial port. GP-IB cables are available from Hioki in two lengths: 9151-02 (2 m) and 9151-04 (4 m).

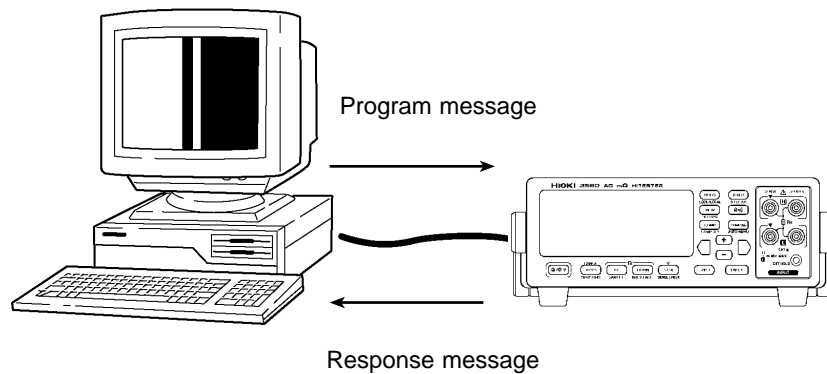

Setting the GP-IB address

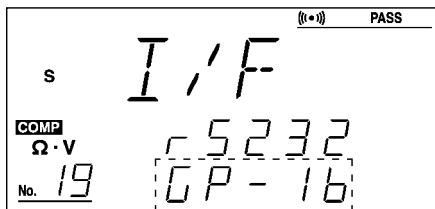

1. Press the **SHIFT** key. "SHIFT" appears lit on the display.
2. Press the **DOWN/INTERFACE** key.
3. Use the **+** and **-** keys to select GP-IB.
4. Press the **ENTER** key.
5. Use the **+** and **-** keys to set the address. You may select numbers in the range from 0 to 30.
6. Press the **ENTER** key to return to the measurement screen.

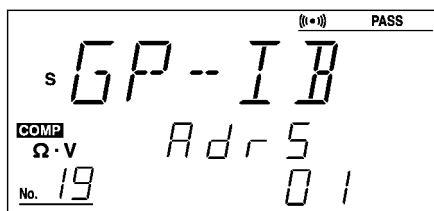

8.2 Operating Procedure (GP-IB)

8.2.1 Communication Methods by the GP-IB

In order to control the 3560 by the GP-IB, there are several kinds of messages. Of these, program messages are those received by the 3560 from the computer, while response messages are those sent from the 3560 to the computer.

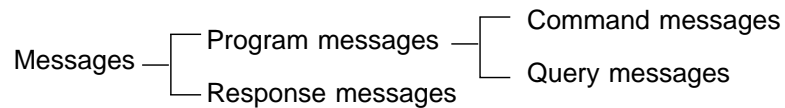

8.2.2 Program Messages

Program messages are command messages or query messages.

(1) Command messages

Command messages are orders for controls of the 3560, such as for making measurement condition settings or for reset or the like.

Example : LIM ON

(2) Query messages

Query messages are order for responses relating to results of measurement, or the state of 3560 settings. (A question mark "?" is suffixed at the end of the command.)

Example : CSET: BEEP?

8.2.3 Message Format

The commands for the 3560 are as far as possible mnemonic. Furthermore, all commands have a long form, and an abbreviated short form.

(1) Program message

The program message is made up from header and data portions.

Example :AUT ON

AUT: Header

ON: Data

(ASCII codes or numerical characters. Messages containing no data also exist in the form of query messages.)

A command header can be abbreviated. The whole command form is referred to as the "long form" and the abbreviated form as the "short form."

In this manual, the short form is written in upper case letters, and then this is continued in lower case letters so as to constitute the long form. Either of these forms will be accepted during operation, but intermediate forms will not be accepted. Further, during operation both lower case letters will be accepted without distinction.

(2) Response messages

It represents the response message for query messages from the 3560. Response messages generated by the 3560 are in long form and in upper case letters.

Example :CSET:BEEPER IN

NOTE

If an error occurs when a query is received, no response message to the query is sent.

8.2.4 Headers

(1) Program message headers

The program message always requires a header.

These are three types of header: simple headers, compound headers, and particular headers.

① Simple header

A header consisting of a single word beginning with a letter.

Example :AUTorange

② Compound header

A header consisting of a sequence of words separated by colons.

Example LOCK:KEY

③ Particular header

A header beginning with an asterisk (*) to indicate that it is a particular command.

Example *CLS

(2) response message

Headers in response message can be enabled or disabled by using the "HEADer" command.

Example "CSET:BEEP?" (Queries the buzzer setting)

Response: [If headers are ON] :CSET:BEEPERIN

Response: [If headers are OFF] IN (Data only)

8.2.5 Data Formats

The 3560 use character string data and decimal numeric data, and the type used varies according to the command in question.

(1) Character data

Character string data must always begin with an alphabetic character, and the characters following can be either alphabetic characters or numerals. Although in character data either upper case letters or lower case letters are accepted, response messages output by the 3560 are always in upper case letters.

Example :LIMIT ON

(2) Decimal data

The numeric data values are all represented in decimal, in three formats identified as NR1, NR2 and NR3, and each of these can appear as either a signed number or an unsigned number. Unsigned numbers are taken as positive.

Further, if the accuracy of a numerical value exceeds the limit which the 3560 can deal, it is rounded off. (5 and above is rounded up; 4 and below is rounded down).

① NR1 format - integer data.

Example +3000, -50000, 210

② NR2 format - fixed point numbers.

Example +2.56, -30.45, 300.28

③ NR3 format - floating point numbers.

Example +3E-2, -1.2E+3

The term "NRf format" includes all these three formats.

When the 3560 is receiving it accepts NRf format, but when it is sending response messages it utilizes whichever one of the formats NR1 to NR3 is indicated in the specified command.

Example :VRAN 5 :VRAN 5.01 :VRAN 0.05E2

8.2.6 Delimiters

The term "delimiter" is used to refer to the following two possibilities for separating data sequences.

EOI
 CR
 CR + EOI
 LF
 LF + EOI
 CR + LF
 CR + LF + EOI

The response message delimiter has the following format:
 CR + LF + EOI

NOTE

The 3560 analyzes the message after checking the delimiter. When using an NEC PC-9801-series computer (and its GP-IB board) as a controller, first execute the "CMD DELIM=0" command to set the delimiter to "CR + LF."

8.2.7 Separators

(1) Message unit separator

A semicolon (;) is used as a message unit separator when it is desired to set out several messages on a single line.

When message are combined in this way, if a syntax error occurs, all subsequent messages up to the next delimiter will be ignored.

Example :RRAN 3E-2;:VRAN 50;:MEAS:BATT

NOTE

When message are combined in this way, if a syntax error occurs, all subsequent messages up to the next delimiter will be ignored.

(2) Header separator

In a message which has a header and data, a space (represented by "(space) in the examples) is used as the header separator to separate the header from the data.

Example :COMPARATOR 1

(3) Data separator

If a message has several data items, commas (,) are required as data separators for separating these data items from one another.

Example :CSET:RPAR *data1,data2*

8.2.8 Abbreviation of Compound Commands

When several compound headers have a common head portion (for example, :CSET:---), then, when and only when writing them directly following on from one another, this common portion (:CSET: in this example) can be omitted.

This common portion is called the "current path", by analogy with the general concept of the current directly in the directly structure of UNIX or MSDOS, and until it is cleared the analysis of following commands is performed by deeming them to be preceded by the current path is shown in the following example:

Normal expression

:CSET:NUMBer ; :CSET:RPARAmeter

Abbreviated expression

:CSET:NUMBer ; RPARAmeter

The current path is cleared when the power is turned on, when a colon (:) appears at the start of a command, and when delimiter is detected.

Messages with particular headers can be executed without relation to the current path. Further, they have no effect upon the current path.

While simple and complex command headers don't require a colon ":" prefix, we recommend using the colon to avoid confusion with abbreviated expressions and to prevent 3560 malfunction.

With the 3560, there are 3 possible current paths:

":CSET", ":LOCK", ":MEAS"

8.2.9 Output Queue

Response messages accumulate in the output queue and all data are received and cleared.

The output queue is also cleared in the following four situations:

- ① When the instrument is powered on.
- ② When the Query error is occurred.
- ③ When the Device is cleared.
- ④ When the I/F is Switched.

The 3560 has an output queue of 128 byte capacity. If the response messages overflow this limit of 128 byte, a query error is generated, and the output queue is cleared. Further, if a new message is received while the output queue still contains data, the output queue is cleared, and a query error is generated.

8.2.10 Input Buffer

The 3560 have an input buffer of 128 bytes capacity.

8.2.11 Status Model

The term "event" refers to any phenomenon which generates a service request.

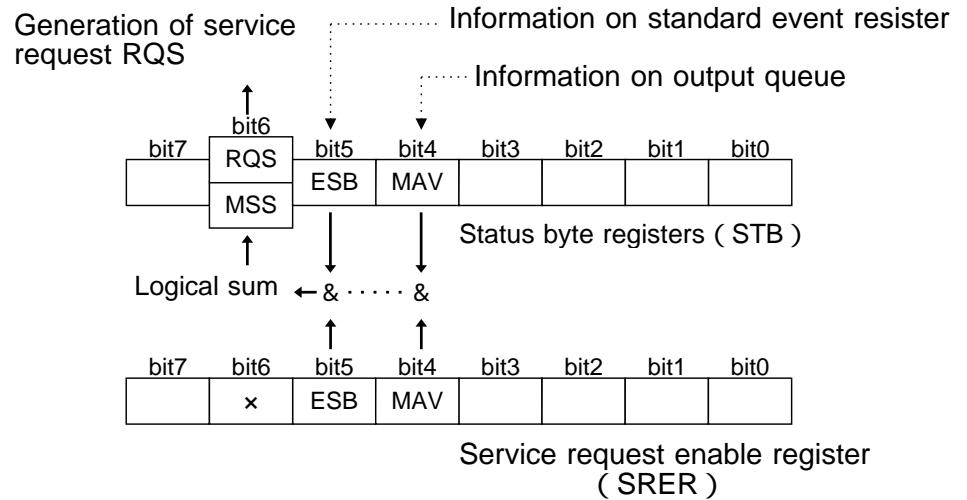

The status byte register holds information relating to the event registers and the output queue. It is further possible to use the service request enable register as a mask to select the items required. If any of the bits selected by the mask becomes 1, bit 6 (the master summary status or MSS bit) is also set to 1, an SRQ message is generated, and this generates a service request.

8.2.12 Status Byte Registers

(1) Status byte register (STB)

The status byte register is an 8-bit register whose contents are output from the 3560 to the controller, when serial polling is being performed. If even only one bit in the status byte register has changed from 0 to 1 (provided that it is a bit which has been set in the service request enable register as a bit which can be used), then the MSS bit is set to 1. Simultaneously with this the SRQ bit is set to 1, and service request is generated.

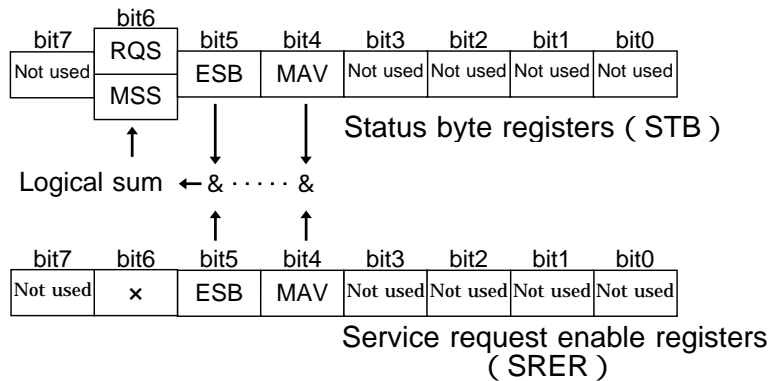

The RQS bit is synchronized with service requests, and is read out and simultaneously cleared when serial polling is being performed. Although the MSS bit is only read out on an *STB? query, on a *CLS command for example it is not cleared until the event is cleared.

Bit	Meaning
7	Not used
6 RQS	RQS is set to "1" after the service request is sent.
MSS	MSS shows the logical sum of other bits in the status byte register.
5 ESB	Standard event summary (logical sum) bit ESB shows the logical sum of the standard event status register.
4 MAV	Message available MAV indicates the output queue has messages.
3	Not used
2	Not used
1	Not used

(2) Service request enable register (SRER)

This register masks the status byte register. Setting a bit of this register to 1 enables the corresponding bit of the status byte register to be used.

8.2.13 Event Registers

(1) Standard event status register (SESR)

The standard event status register is an 8-bit register. If any bit in the standard event status register is set to 1 (after masking by the standard event status enable register), bit 5 (ESB) of the status byte register is set to 1.

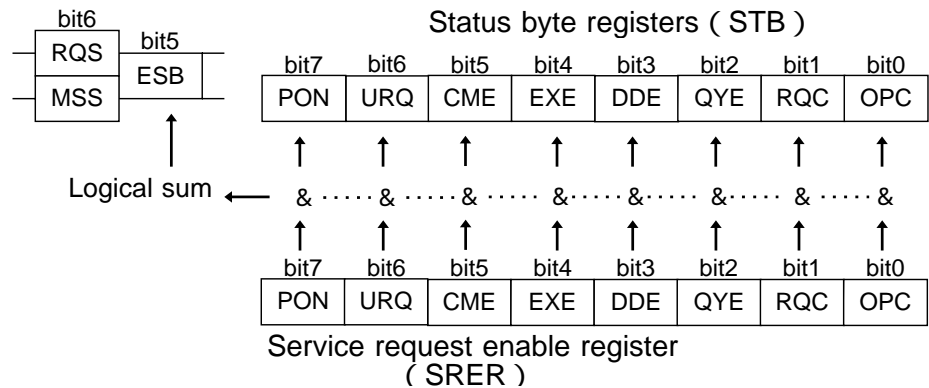

The standard event status register is cleared in the following three situations:

- ① When a *CLS command is received.
- ② When an *ESR? query is received.
- ③ When the instrument is powered on.

(2) Standard event status enable register (SESER)

Setting any bit of the standard event status enable register to 1 enables the corresponding bit of the standard event status register to be accessed.

Standard event status register

Bit 7 PON	Power-on flag PON is set to "1" when the 3560 is turned on or restored from a power failure.
Bit 6 URQ	User request This bit is not used in the 3560.
Bit 5 CME	Command error (Commands up to the message terminator are ignored.) CME is set to "1" when the command received has the following syntax or interpretation errors: <ul style="list-style-type: none"> • A command not defined in the 3560 is received. • The program header is invalid. • The data quantity differs from the specified value. • The data format differs from that specified.
Bit 4 EXE	Execution error EXE is set to "1" when the command received cannot be executed because: <ul style="list-style-type: none"> • The specified data deviates from the specified range. • The specified data is not acceptable.
Bit 3 DDE	Error resulting from device malfunction. DDE is set to "1" if the command cannot be executed for any reason other than command, query, or execution errors. <ul style="list-style-type: none"> • The command cannot be executed, due to an error within the 3560. • The command cannot be executed, because another function is already active.
Bit 2 QYE	Query error (The output queue is cleared.) The query error is detected by the output queue controller and QYE set to "1" when the following events occur: <ul style="list-style-type: none"> • An attempt is made to read an empty output queue. • The response exceeds 128 bytes. • The next message is received while the output queue contains data. • A query exists after the *IDN? query on the same line.
Bit 1 RQC	Controller privilege request This bit is not used in the 3560.
Bit 0 OPC	Operation complete OPC is set to "1" when (for example) the *OPC command executes: * When all actions specified by messages up to the *OPC command are complete

Register read/write command list

Register	Read	Write
Status byte register	*STB?	
Service request enable register	*SRE?	*SRE
Standard event status register	*ESR?	
Standard event status enable register	*ESE?	*ESE

NOTE

All adjustments made to the settings of the 3560 are stored in the internal EEPROM, for which the number of write operations is limited. When the EEPROM reaches the end of its life, the error message "ERR-3" appears. 3560 is turned off or data is not correctly written due to a faulty EEPROM while the measurement conditions are being set in the EEPROM of the 3560. Contact your dealer or Hioki representative.

8.2.14 GP-IB Command

Interface functions permit use of the following commands:

Command	Function
GTL	Go To Local The remote state is canceled, and the system goes into the local state.
LLO	Local Lock Out All keys, including the LOCAL key, becomes out of operating.
DCL	Device Clear Clears the input buffer and the output queue.
SDC	Selected Device Clear Clears the input buffer and the output queue.
GET	Group Execute Trigger During the holding state, perform one-shot measurement.

NOTE

Using the GET (GroupExecute Trigger) command in non-hold mode will produce an execution error.

The following items are the same as for the RS-232C interface. See Chapter 7 "RS-232C Interface."

Message Code Table

Common command

Message reference

Common command

Messages

Initialize Item List

8.3 Sample Program

The program shown below is described in HPBASIC which is created by using the HP's controller. For information on HPBASIC, refer to its user's manual. All the messages in the sample program are described in shortened form. The GP-IB address of the 3560 is set to "1".

(1) 3560 inquiry program

This program initializes the 3560. It inquires to determine the manufacturer, model name, and software version. This program also executes the self test and inquires to determine the result.

Program list	Program comments
100 DIM A\$[100]	100 Defines character strings
110 DIM B\$[100]	110 Defines character strings
120 CLEAR 701	120 Initialize the interface
130 OUTPUT 701;"*RST"	130 Initialize the 3560
140 OUTPUT 701;"*IDN?"	140 Query device ID
150 ENTER 701;A\$	150 Get data
160 PRINT A\$	160 Display data
170 OUTPUT 701;"*TST?"	170 Execute and query self test
180 ENTER 701;B\$	180 Get data
190 PRINT B\$	190 Display data
200 END	200 End of program

(2) 3560 measurement mode, sampling rate, and measurement range setup program

This program sets the measurement mode, sampling rate, and measurement range of the 3560, and inquires to determine the established settings.

100 DIM M\$[10],S\$[10],AR\$[10]	100 Defines character strings
110 DIM A\$[50],B\$[50],C\$[50],D\$[50],E\$[50]	110 Defines character strings
120 CLEAR 701	120 Initialize the interface
130 INPUT"MODE? (R/RV) ";M\$	130 Specify the measurement mode
140 IF M\$="R" THEN 160	140 Select the measurement mode
150 IF M\$="RV" THEN 180	150
160 OUTPUT 701;" :MOD R"	160 Set the measurement mode (Resistance mode)
170 GOTO 190	170
180 OUTPUT 701;" :MOD RV)	180 Set the measurement mode (Resistance and voltage mode)
190 INPUT"SAMPLING? (F/M/S) ";S\$	190 Specify the sampling rate
200 IF S\$="F" THEN 230	200 Select the sampling rate
210 IF S\$="M" THEN 250	210
220 IF S\$="S" THEN 270	220
230 OUTPUT 701;"SAMP FAST"	230 Set the sampling rate to FAST
240 GOTO 280	240
250 OUTPUT 701;"SAMP MED"	250 Set the sampling rate to MEDIUM
260 GOTO 280	260
270 OUTPUT 701;"SAMP SLOW"	270 Set the sampling rate to SLOW
280 INPUT"AUTORANGE? (A/M) ";Ar\$	280 Specify the auto range
290 IF Ar\$="A" THEN 310	290 Select the range
300 IF Ar\$="M" THEN 330	300
310 OUTPUT 701;" :AUT ON"	310 Set the auto range to ON
320 GOTO 410	320
330 OUTPUT 701;" :AUT OFF"	330 Set the auto range to OFF
340 INPUT"RESISTANCE_RANGE? (0 - 3100) ";Rr	340 Specify the resistance range
350 IF Rr<0 OR Rr>3100 THEN 340	350
360 OUTPUT 701;" :RRAN ";Rr	360 Set the resistance range
370 IF M\$="R" THEN 410	370
380 INPUT"VOLTAGE_RANGE? (-50 - 50) ";Vr	380 Specify the voltage range
390 IF Vr<-50 OR Vr>50 THEN 380	390
400 OUTPUT 701;" :VRAN ";Vr	400 Set the voltage range
410 OUTPUT 701;" :MOD?"	410 Query the measurement mode
420 ENTER 701;A\$	420 Get data
430 OUTPUT 701;" :SAMP?"	430 Query the sampling rate
440 ENTER 701;B\$	440 Get data
450 OUTPUT 701;" :AUT?"	450 Query the autorange
460 ENTER 701;C\$	460 Get data
470 OUTPUT 701;" :RRAN?"	470 Query the resistance range
480 ENTER 701;D\$	480 Get data
490 IF M\$="R" THEN 540	490
500 OUTPUT 701;" :VRAN?"	500 Query the voltage range
510 ENTER 701;E\$	510 Get data
520 PRINT A\$,B\$,C\$,D\$,E\$	520 Display data (Resistance and voltage measurement mode)
530 GOTO 550	530
540 PRINT A\$,B\$,C\$,D\$	540 Display data (Resistance and voltage measurement mode)
550 END	550 End of program

(3) 3560 comparator setup program

This program sets comparators for the 3560 and inquires to determine the established settings.

100 DIM Cm\$[10]	100 Defines character strings
110 DIM Rbm\$[10], Vbm\$[10]	110 Defines character strings
120 CLEAR 701	120 Initialize the interface
130 OUTPUT 701; ":HEAD OFF"	130 Set the header
140 INPUT "COMPARATOR NUMBER? (1 - 30) "; Nu	140 Specify the comparator number
150 IF Nu<1 OR Nu>30 THEN 140	150
160 OUTPUT 701; ":CSET:NUMB "; Nu	160 Set the comparator number
170 INPUT "COMPARATOR MODE? (R/RV) "; Cm\$	170 Specify the measurement mode of the comparator
180 IF Cm\$<>"R" AND Cm\$<>"RV" THEN 170	180
190 OUTPUT 701; ":CSET:MOD "; Cm\$	190 Set the measurement mode of the comparator
200 INPUT "COMPARATOR RESISTANCE_RANGE? (0 - 3100) "; Rr	200 Specify the resistance mode of the comparator
210 IF Rr<0 OR Rr>3100 THEN 200	210
220 OUTPUT 701; ":CSET:RRAN "; Rr	220 Set the resistance range of the comparator
230 OUTPUT 701; ":CSET:RRAN?"	230 Query the resistance range of the comparator
240 ENTER 701; Rn	240 Get data
250 IF Cm\$="R" THEN 300	250 Select the measurement mode
260 INPUT "COMPARATOR VOLTAGE_RANGE? (-50 - 50) "; Vr	260 Specify the voltage range of the comparator
270 OUTPUT 701; ":CSET:VRAN "; Vr	270 Set the voltage range of the comparator
280 OUTPUT 701; ":CSET:VRAN?"	280 Query the voltage range of the comparator
290 ENTER 701; Vn	290 Get data
300 INPUT "RESISTANCE_PARAMETER? UPPER(0 - RANGE) "; Rh	300 Specify the upper resistance value
310 INPUT "RESISTANCE_PARAMETER? LOWER(0 - RANGE) "; Rl	310 Specify the lower resistance value
320 IF Rh>Rn OR Rl>Rn THEN 300	320
330 OUTPUT 701; ":CSET:RPAR "; Rh; ", "; Rl	330 Set the upper and lower resistance value
340 IF Cm\$="R" THEN 400	340 Select the measurement mode
350 INPUT "VOLTAGE_PARAMETER? UPPER(0 - RANGE) "; Vh	350 Specify the upper voltage value
360 INPUT "VOLTAGE_PARAMETER? LOWER(0 - RANGE) "; Vl	360 Specify the lower voltage value
370 IF Vh>Vn OR Vl>Vn THEN 350	370
380 OUTPUT 701; ":CSET:VPAR "; Vh; ", "; Vl	380 Set the upper and lower voltage value
390 GOTO 440	390
400 INPUT "BEEPER MODE? (OFF/IN/HL) "; Rbm\$	400 Specify the buzzer (Resistance measurement mode)
410 IF Rbm\$<>"OFF" AND Rbm\$<>"IN" AND Rbm\$<>"HL" THEN 400	410
420 OUTPUT 701; "CSET:BEEP "; Rbm\$	420 Specify the buzzer (Resistance measurement mode)
430 GOTO 470	430
440 INPUT "BEEPER MODE? (OFF/PASS/FAIL) "; Vbm\$	440 Specify the buzzer (Resistance and voltage measurement mode)
450 IF Vbm\$<>"OFF" AND Vbm\$<>"PASS" AND Vbm\$<>"FAIL" THEN 440	450
460 OUTPUT 701; "CSET:BEEP "; Vbm\$	460 Specify the buzzer (Resistance and voltage measurement mode)
470 END	470 End of program

8.4 Notes of the GP-IB

Symptom	Cause/Treatment
The GP-IB has stopped working completely.	Are the cables properly connected?
	Is the device address for the 3560 set correctly?
	Do some other devices have the same GP-IB address?
	Are all the devices powered on?
After transmission on the GP-IB bus, the keys on the 3560 freeze up and have no effect.	Press the LOCK key on the 3560 to release the remote state.
	Has a LLO (Local Lock Out) command been transmitted? Transmit a GTL (Go To Local) command to put the 3560 into the local state.
When attempting to read data using a Basic INPUT@ statement, the GP-IB bus hangs.	Be sure to transmit one query before each INPUT@ (ENTER) statement.
	Have any of these transmitted queries resulted in an error?
Although a command has been transmitted, nothing has happened.	Using *ESR? command, inspect the contents of the standard event status register, and check what type of error has occurred.
Sending several queries, produce only one response.	Has an error occurred?
	Read the response whenever transmitting each query. When you want to read them in all at once, try putting them all on one line using the message separator.
	Have *IDN? query been used?
The service requests are not generated sometimes.	Have the service request enable register and the standard event status enable register been set correctly?
	Clear the standard event register at the end of RQS processing subroutines with *CLS command. Unless the bit of the event has been cleared once, no service request would have generated in the same event.
The response message to a query differs from the display of the 3560.	The response message is produced at the instant that the 3560 receives the query, and there is a possibility that it may not agree with the display.

Chapter 9

Printer Interface (Option)

9.1 Outline

After mounting an optional 9589 PRINTER INTERFACE to the 3560, you can connect a 9203 DIGITAL PRINTER or general-purpose Centronics printer to print out measurement results. If the 9203 DIGITAL PRINTER is connected, the 9203 can process the data statistically, and the processed data can be printed out by the digital printer.

This chapter explains how to connect a general-purpose Centronics printer to the 3560, and gives procedures for printing measurement results.

The 9203 DIGITAL PRINTER driver must be version 2.00 or later preferably later, as even version 2.00 will produce printer errors. For upgrades, please contact the nearest Hioki sales representative. To find the driver version number, please look in the printer operating manual.

9.2 Connection with a General-purpose Centronics Printer

Connecting a General-purpose Centronics Printer

The 3560 accepts the 9588 GP-IB INTERFACE or 9589 PRINTER INTERFACE. For more information on mounting the interface, see Section 3.1 "Mounting the Interface."

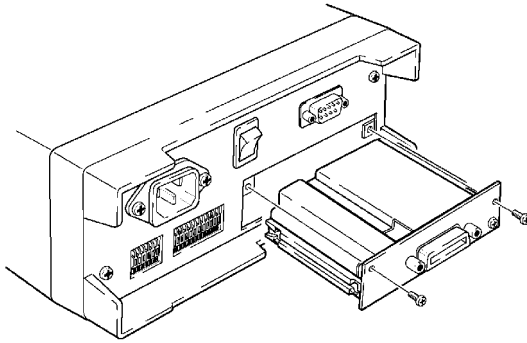

The 9589 PRINTER INTERFACE is connected to the printer with a 9425 CONNECTION CABLE, purchased separately. With a commercially-available connection cable, cables such as the following can be plugged into the standard 36-pin connector (general Centronics printer connector).

PC-9801N-19 (NEC): 1.5 m

PC-9801LV-13 (NEC): 1.0 m

NOTE

- Since the printer interface complies with the Centronics standard, your printer should also conform to this standard.
- To connect the 3560 to the 9203 DIGITAL PRINTER, use the 9425 CONNECTION CABLE and the leads supplied with the 9203.
9425: Connects the interface of the 3560 to the 9203.
Leads supplied with the 9203: Connect the GND terminal of the 3560 to the GND terminal of the 9203 and the PRINT terminal of the 3560 to the TRIG terminal of the 9203.

Connector

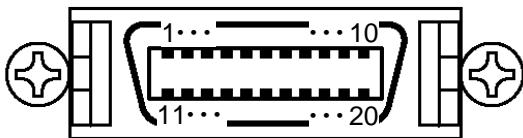

The 3560 has the following or equivalent printer interface connector:

Socket: DHA-RC20-R132N (manufacturer: Daiichi Denshi Kogyo (DDK)) 20-pin half-pitch connector

Pin: DHA-RC20-3G (manufacturer: Daiichi Denshi Kogyo (DDK)) 20-pin half-pitch plug

Pin assignment and signals

Number	Input and output	Signal	Number	Input and output	Signal
1	GND	GND	11	OUT	DATA 7
2	****	****	12	OUT	DATA 6
3	OUT	DATA 5	13	GND	GND
4	OUT	DATA 4	14	****	****
5	OUT	DATA 3	15	GND	GND
6	GND	GND	16	OUT	DATA 2
7	****	****	17	OUT	DATA 1
8	OUT	DATA 0	18	GND	GND
9	OUT	STB	19	****	****
10	IN	BUSY	20	GND	GND

9.3 Printing

This section explains how to output data to a general-purpose Centronics printer. Measure the resistance or resistance and voltage. For measurement methods, see Chapter 4 "Measurement Procedure." Change the PRINT (print trigger) of the external control terminal from "H" to "L." For more information on this, see Chapter 6 "External Control Terminal and External Output Terminal." On receiving the print trigger signal from the external control terminal, the printer outputs the measured values and comparator result as follows:

```
START '98-11- 4 14:36:54
1 14:36:54 0.4950 Ω IN
2 14:36:59 0.4951 Ω IN
3 14:37:02 0.4951 Ω IN
4 14:37:07 0.4951 Ω IN
5 14:37:08 0.4951 Ω IN
6 14:37:09 0.4950 Ω IN
7 14:37:10 0.4951 Ω IN
8 14:37:11 0.4951 Ω IN
9 14:37:12 0.4951 Ω IN
10 14:37:13 0.4951 Ω IN
END '98-11- 4 14:37:16

STATISTICS
N = 10 (* 10)
AVE = 495.080mΩ
MIN = 0.4950 Ω ( 6)
MAX = 0.4951 Ω ( 10)
σn = 0.040mΩ
σn-1 = 0.042mΩ
Cp = 20059.59
CpK = 3516.45
```

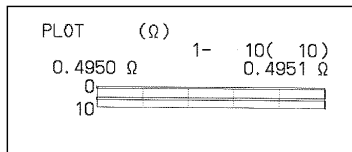
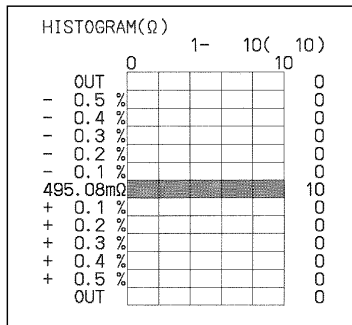

Resistance measurement mode

```
START '98-11- 4 13:29:14
1 13:29:14 106.91mΩ Pass
20.513 V
2 13:29:16 106.91mΩ Pass
20.513 V
3 13:29:18 106.91mΩ Pass
20.513 V
4 13:29:20 106.91mΩ Pass
20.513 V
5 13:29:22 106.91mΩ Pass
20.512 V
7 13:29:29 106.92mΩ Pass
20.513 V
8 13:29:31 106.96mΩ Pass
20.513 V
9 13:29:33 106.92mΩ Pass
20.513 V
10 13:29:35 106.92mΩ Pass
20.513 V
END '98-11- 4 13:29:37

STATISTICS
N = 10 (* 9)
AVE = 106.919mΩ
MIN = 106.91mΩ ( 5)
MAX = 106.96mΩ ( 8)
σn = 0.015mΩ
σn-1 = 0.016mΩ
Cp = 52341.74
CpK = 1168.37

STATISTICS
N = 10 (* 10)
AVE = 20.272 V
MIN = 18.108 V ( 6)
MAX = 20.513 V ( 10)
σn = 0.721 V
σn-1 = 0.760 V
```

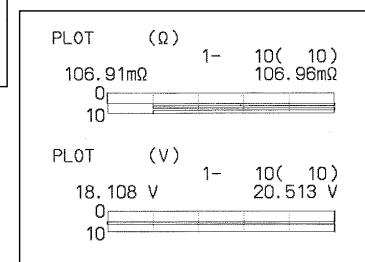
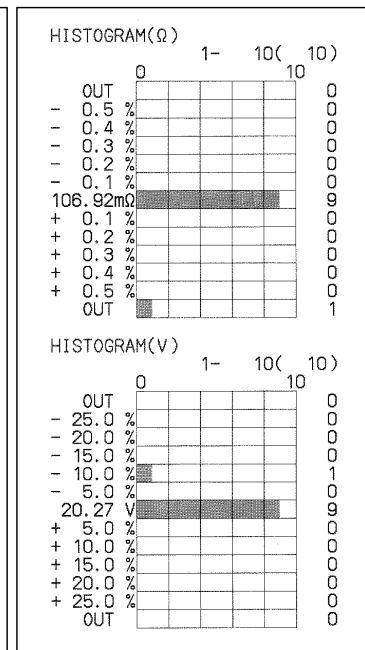

Resistance and voltage measurement mode

NOTE

- Data is not printed in either setup mode - that is, when no measurements are being made.
- If the comparator is not used, no comparator result is printed.
- "OF" is printed if an overflow occurs. "NG" is printed to indicate abnormal measurements.
- With the 9203 DIGITAL PRINTER connected, abnormal measurements will cause " " to be printed.

Chapter 10

Useful Information and Advanced Measurement

10.1 AC Four-terminal Method

The 3560 uses the AC four-terminal method, so that resistance measurement can be carried out with the resistance of the leads and the contact resistance between the leads and the object to be measured canceled out. The following figure shows the principle of the AC four-terminal measurement method.

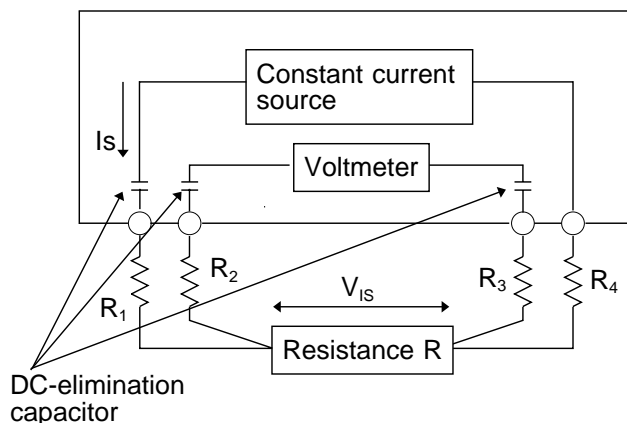

Resistance measurement circuit

Values R_1 to R_4 are the resistances of the measurement leads plus contact resistances.

In the 3560, a synchronized wave detection system is used, whereby the internal impedance is separated into resistance and reactance, and the resistive component only displayed.

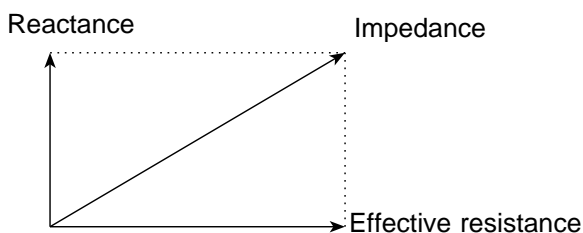

If the lead resistance, the contact resistance between measured object and lead, or the contact resistance between the lead and the 3560 instrument increases, the 3560 can no longer supply normal current to the measured object, resulting in an abnormal measurement status indicated by "____" within the measured resistance field. For more information on abnormal measurements, see Section 4.5 "Starting Measurement"

10.2 Synchronous Detection System

The figure below shows an equivalent circuit for a battery. If the measured object exhibits other electrical characteristics in addition to resistance, as shown in this figure, we can use the synchronous detection system to obtain the effective resistance of the object. This synchronous detection system is also used to separate faint signals from noise.

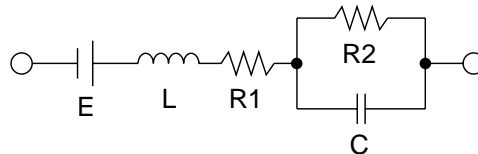

The synchronous detection system picks up the reference signal and those signals having the same phase components. The figure below gives a simplified schematic diagram of the synchronous detection system. The system consists of a multiplying circuit that multiplies two signals and a low-pass filter (LPF) that picks up only DC components from the output.

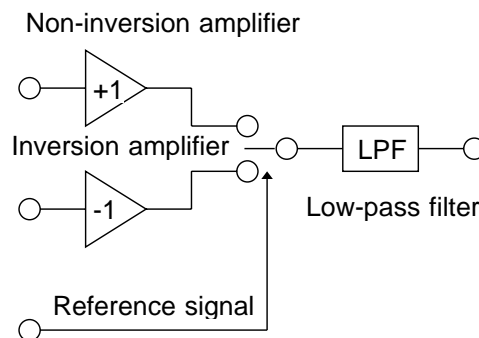

Given " v_1 ," a reference signal voltage for the AC current generated in the 3560, and " v_2 ," the signal voltage for use in synchronous detection, these parameters may be expressed by the equation given below. ϕ of v_2 shows the phase difference against v_1 and is generated by the reactance.

$$v_1 = A \sin \omega t$$

$$v_2 = B \sin(\omega t + \phi)$$

When synchronous detection is applied to both v_1 and v_2 , they are expressed as follows:

$$v_1 \times v_2 = \frac{1}{2}AB \cos \phi - \frac{1}{2}AB \cos(2\omega t + \phi)$$

The first term indicates effective resistance. The second term is attenuated by the LPF. The 3560 displays the first term.

10.3 Configuration and Extension of the Measurement Leads

Measurement lead extension is normally performed by Hioki. If you want extension performed, contact your dealer or Hioki representative.

Observe the following points when extending measurement leads:

1. Use the thickest lead available. Extend the lead only by the necessary amount.
2. Maintain the AC four-terminal configuration while extending the lead. Changing the four-terminal configuration to a two-terminal configuration can result in measurement data being affected by lead resistance and/or contact resistance, resulting in inaccurate measurement.
3. Make the branch section as short as possible. Try to extend the thick lead instead.
4. Make sure the lead is insulated.
5. Try to maintain the same lead arrangement and configuration for both zero-adjust and actual measurement.
6. Extending a lead increases the voltage drop in the lead. Do not exceed the permissible resistance for the extended lead per range defined by the 3560. Over-extending a lead can lead to resistance not being measured to the maximum count (SLOW/MEDIUM: 31000 counts, FAST: 3100 counts).
7. To prevent eddy currents from affecting measurement, keep measurement leads away from metallic parts.
8. After the lead is extended, check it for operating capability, accuracy, and the like.

Maximum lead extension (Figures provided in this table are for reference only; their accuracy is not guaranteed.)

Resistance range ()	Lead resistance and contact resistance	SENSE line break check / Voltage limiter			
		OFF/ON ()	OFF/ON ()	ON/OFF ()	ON/OFF ()
30 m	RC1+RL+RC2 RC2	1.4 900 m	400 m 400 m	1.4 300 m	400 m 300 m
300 m	RC1+RL+RC2 RC2	13 7.5	5 5	13 13	5 3.3
3	RC1+RL+RC2 RC2	125 76	55 55	130 34	55 34
30	RC1+RL+RC2 RC2	990 760	260 260	990 333	260 200*
300	RC1+RL+RC2 RC2	2.3 k 1.5 k	890 890	2.3 k 640	890 520*
3 k	RC1+RL+RC2 RC2	8.7 k 5.1 k	3.9 k 3.9 k	8.7 k 1.9 k	3.9 k 330*

RL: Measurement object

RC1: "Hi" lead resistance + contact resistance

RC2: "Lo" lead resistance + contact resistance

*: RL = F.S.

Reducing induced voltage

Since the 3560 measures a minute resistance with AC power, it is affected by induced voltage. Induced voltage refers to voltage that allows the current generated in the 3560 to build an inductive coupling in a lead and affect signal lines. Since the phase of the induced voltage is shifted from that of the AC current (reference signal) by 90 degrees, it can be eliminated with the synchronous detection circuit if the voltage is low. But for high levels, the induced voltage distorts the signals, causing incorrect synchronous detection. The 3560 monitors induced voltage internally and generates an abnormal measurement signal if the level rises above a certain level. Reducing the length of the lead will lower induced voltage. Reducing the length of the branched section is particularly effective.

Measurement lead structure

The figure below illustrates the structure of the measurement lead.

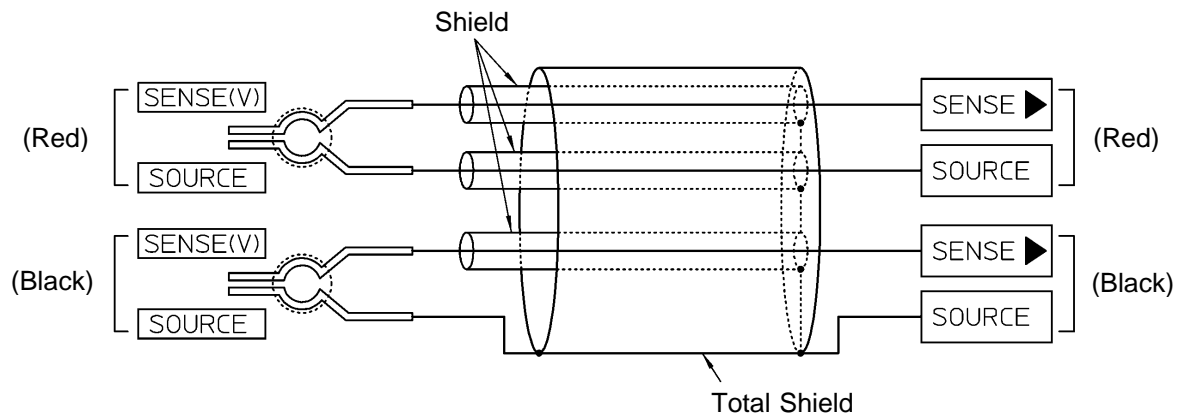

10.4 Effect of Eddy Currents

The AC current generated in the 3560 induces eddy currents in the surrounding metallic plates, which generate induced voltage in the measurement lead. Since the phase of this induced voltage is shifted from that of the AC current (reference signal) by 180 degrees, it cannot be eliminated by the synchronous detection circuit, resulting in measurement errors. The influence of eddy currents is a phenomenon unique to ohmmeters that measure resistance with AC power. To protect the measurement lead from such effects, keep metallic parts, including metallic plates, at a suitable distance from the measurement lead (branched section).

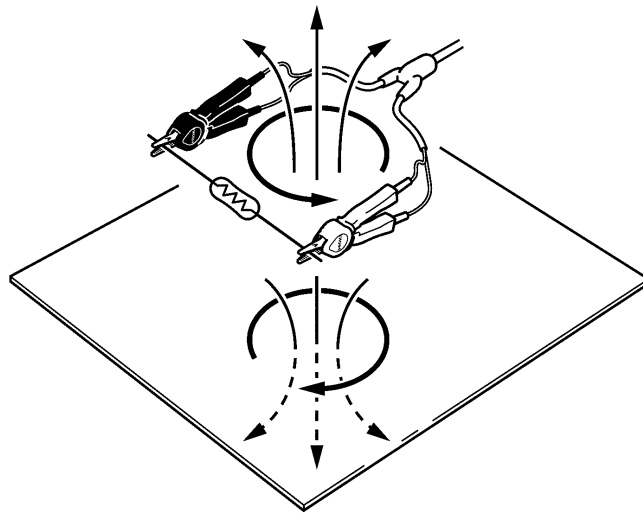

10.5 SOURCE/SENSE Line Break Check

The 3560 supports SOURCE line break check and SENSE line break check functions. The SOURCE line break check function may be enabled or disabled. The figure below gives a SOURCE line break check circuit diagram. If a broken SOURCE line is detected or measured resistance deviates from the specified range, an abnormal measurement signal is output.

The figure below shows a SENSE line break check circuit diagram. In the SENSE line break check, a low current is supplied to the SENSE line to detect breaks, in addition to the measurement current. Since the frequency of this detection current differs from that of the measurement current, measurement remains unaffected by the detection current. If a low current input leads to problems, the SENSE line break check function should be disabled.

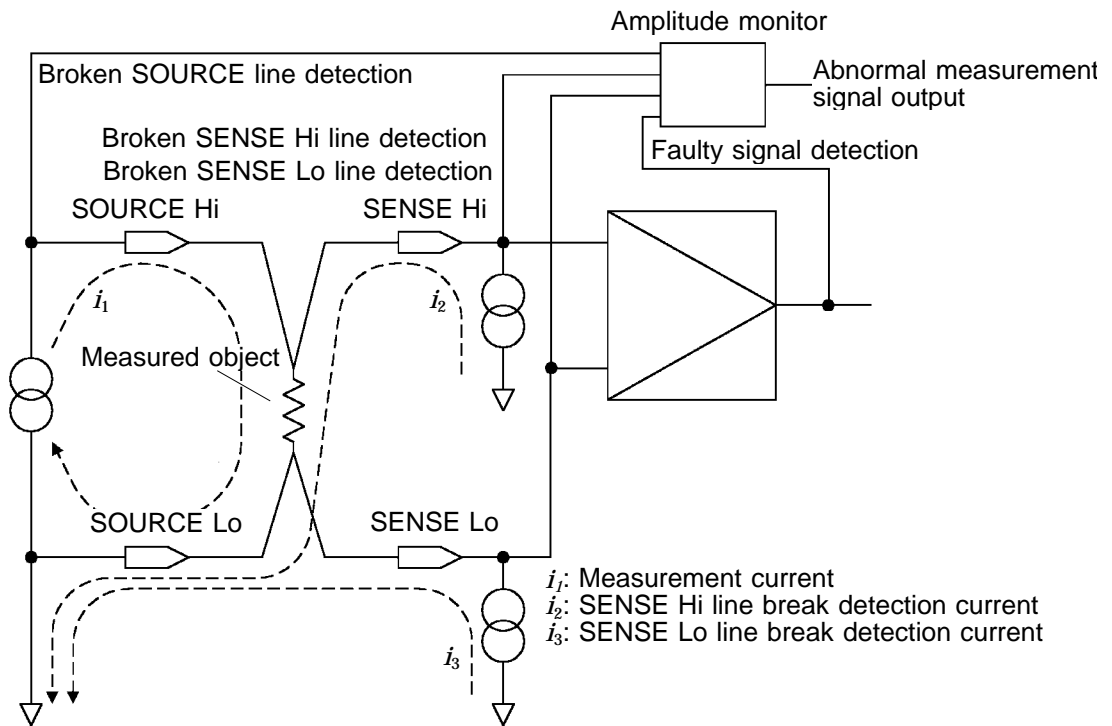

10.6 IEC 512-2, JIS C 5402 and JIS C 5441

IEC 512-2

Electromechanical components for electronic equipment; basic testing procedures and measuring methods.

Measurement frequency:	2 kHz, max.
Measurement Accuracy:	10%, max
Open-circuit terminal voltage:	20 mV _{peak} , max
Measurement current:	100 mA, max

JIS C 5402 (Japanese Industrial Standards)

Testing methods of switches for use in electronic equipment.
Method for test of connectors for use in electronic equipment.

Measurement frequency:	2 kHz or less
Measurement Accuracy:	10%
Open-circuit terminal voltage:	20 mV _{peak}
Measurement current:	100 mA or less

JIS C 5441 (Japanese Industrial Standards)

Testing methods of switches for use in electronic equipment.
Low-voltage and low-current method

Measurement frequency:	2 kHz or less
Open-circuit terminal voltage:	20 mV _{peak} or less
Measurement current:	100 mA or less

10.7 Example of Advanced Measurements

Measuring Contact Resistance at High Speeds

The 3560 supports a sampling rate of 50 samples per second (around 50 Hz) or 60 samples per second (around 60 Hz). The instrument supports an analog response of about 100 ms (in 50 Hz area) or 84 ms (in 60 Hz area), with response time varying with the object measured. Note that these specifications are based on the FAST sampling rate. For maximum performance, we recommend using the hold and trigger functions. For more information on these functions, see Section 4.3.3 "Hold" and Chapter 6 "External Control Terminal and External Output Terminal." For high-speed measurement, the permissible measurement range should not be reduced excessively in the comparator setting. In other words, setting a wide measurement range is preferable as long as the nature of the object to be measured is taken into consideration.

Measuring the Internal Resistance and Circuit Voltage of a Battery

Use the resistance and voltage mode. For more information on resistance and voltage mode, see Chapter 4 "Measurement Procedure." In resistance and voltage mode, resistance and voltage are both subject to comparator operation.

10.8 Calibration of the 3560

For the calibration environment, see 2.2 "Measurement Range."

Calibration of the Ohmmeter

- Use the 9453 FOUR TERMINAL LEAD as the connection lead.
- Use standard resistors with excellent temperature characteristics that resist deterioration over time.
- To prevent influence by the lead, use four-terminal resistors.
- Use a resistor that will reflect the correct resistance at 1 kHz. With wire-wound resistors, the inductance element is so large that the pure resistance (DC resistance) does not equal the effective resistance (real part of impedance, displayed on the 3560).
- For connection of a standard resistor to the 3560, see the figure below.

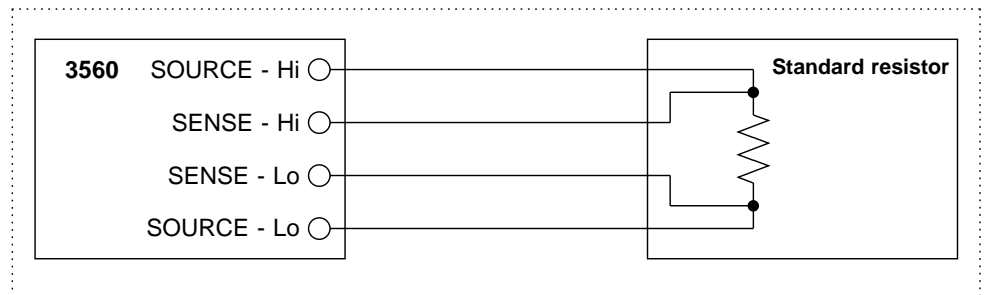

Calibration of the Voltmeter

- Use the 9453 FOUR TERMINAL LEAD as the connection lead.
- Use a generator that can output a DC voltage of 4.9 V or 49 V.
- For connection of a generator to the 3560, see the figure below.
- Do not apply an alternating current from the 3560 to the generator, as the generator may malfunction.

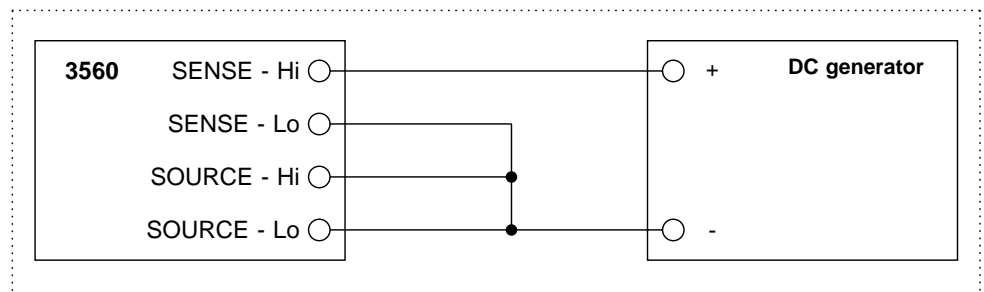

Chapter 11

Maintenance and Service

11.1 Message Code Table

The following messages appear on the display of the 3560.

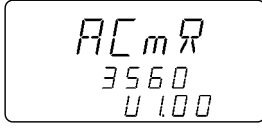
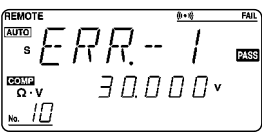
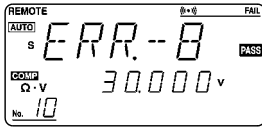
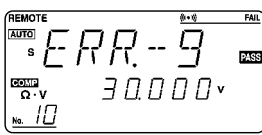
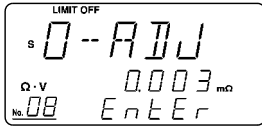
	<p>This message appears whenever the 3560 is turned on, and indicates the model name and the software version.</p>
	<p>Zero adjust error This message indicates that the measured value is out of range in the zero-adjustment mode. See Section 4.4 "Zero Adjust"</p>
	<p>EEPROM error This message appears whenever the 3560 is turned off or data is not correctly written due to a faulty EEPROM while the measurement conditions are being set in the EEPROM of the 3560. Contact your dealer or Hioki representative.</p>
	<p>System error The ROM or RAM of the 3560 is faulty. Contact your dealer or Hioki representative.</p>
	<p>This message indicates that Hioki's adjustment program is active. When this message appears, immediately turn off the 3560 and turn it on again. If you continue to operate the keys without initiating this reboot sequence, the corrected data will be lost and consequently the 3560 will not work correctly.</p>

11.2 Cleaning

To clean the instrument, wipe it gently with a soft cloth moistened with water or mild detergent. Never use solvents such as benzene, alcohol, acetone, ether, ketones, thinners or gasoline, as they can deform and discolor the case.

11.3 Troubleshooting

If damage is suspected, check the "Troubleshooting" section before contacting your dealer or Hioki representative.

When sending the instrument for repair, pack carefully to prevent damage in transit. Include cushioning material so the instrument cannot move within the package. Be sure to include details of the problem. Hioki cannot be responsible for damage that occurs during shipment.

Symptom	Cause	Follow-up
Display is not lit when the powerswitch is turned on.	Power cord is not correctly connected.	Connect the power cord correctly. See section 3.2 "Connecting the Power Cord."
	The power-supply voltage is not consistent with the value indicated on the 3560.	Use the power-supply voltage indicated by the 3560.
The measured value is not displayed. Measurement values are wrong.	Leads are not correctly connected.	Connect leads correctly.
	Leads are broken.	Replace with a new cord.
	A measurement object having a large reactance is measured.	Attempt to measure an object having a small reactance.
	Power supply frequency is not correctly set.	Set the power supply frequency correctly. See Section 3.5 "Setting the Power Supply Frequency."
	The preheating time is short.	Ensure that sufficient preheating time is provided prior to measurement. See Section 3.4 "Powering On/Off."
	ERR-8 is displayed continuously.	The EEPROM of the 3560 is faulty. See Section 11.1 "Message Code Table."
	The resistance/voltage range is not appropriate.	Select a range suitable for the measurement object. See Section 4.2 "Setting the Measurement Range."
The key operation is rejected.	Key lock is active.	Cancel the key lock. See Section 4.3.7 "Key Lock."
	Remote mode is active.	Cancel the remote mode. See Section 4.3.8 "Local."
Key lock can not be cancelled. Remote can not be cancelled.	LLO is executed by GP-IB.	Execute GTL (go to local) by GP-IB. See Section 8.2 "Operating Procedure (GP-IB)."
	The external control terminals (COMP0 to COMP4) are selected.	Cancel selection of the external control terminals (COMP0 to COMP4). See Section 6.3.1 "External Control Terminal."

11.4 Options

11.4.1 9588 GP-IB INTERFACE

Applicable standard: IEEE-488.1 1987

Reference standard: IEEE-488.2 1987

For more information on commands and mounting the 9588 GP-IB INTERFACE, see Chapter 4 "Measurement Procedure" and Chapter 8 "GP-IB Interface (Option)."

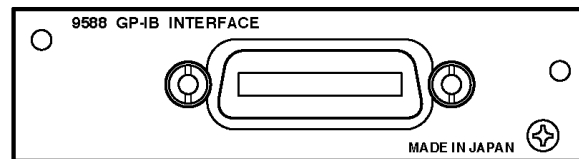

11.4.2 9589 PRINTER INTERFACE

Connecting an optional 9203 DIGITAL PRINTER or general-purpose Centronics printer gives you the option of printing measurement results. For more information on the 9589 PRINTER INTERFACE, see Chapter 9 "Printer Interface (Option)."

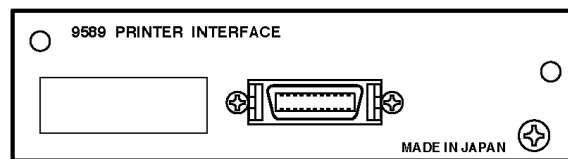

11.4.3 9203 DIGITAL PRINTER

The 9203 DIGITAL PRINTER is specifically intended for use with Hioki measurement equipment. It can print both data and determination results. If the 9203 DIGITAL PRINTER is connected, the 3560 can perform statistical data processing, including determinations of maximum, minimum, standard deviation, and histogram and produce graphs of measurement data. For more information, refer to the operating manual for the 9203 DIGITAL PRINTER.

Dimensions: approx. 215W × 160H × 55D mm

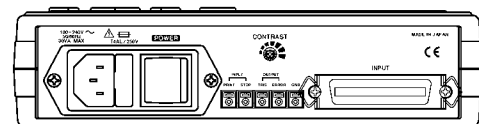
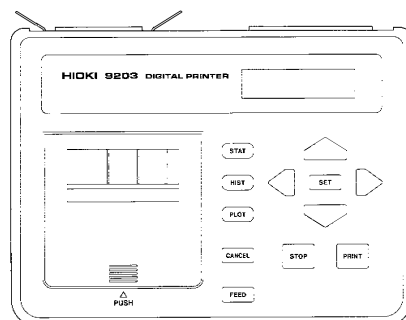

11.4.4 9287-10 CLIP TYPE LEAD (Option)

Clip-type lead supplied with the 3560

Distance between the connector and the branch: approx. 150 mm

Distance between the branch and the probe end: approx. 840 mm

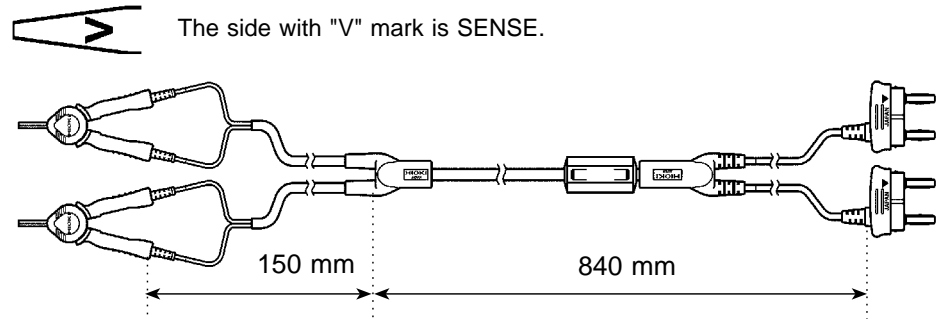

11.4.5 9452 CLIP TYPE LEAD

The 9452 CLIP TYPE LEAD has a bill-like nose, designed to ensure four-terminal measurement even with objects having small contact areas, such as relay terminals and connectors.

Distance between the connector and the branch: approx. 800 mm

Distance between the branch and the probe end: approx. 200 mm

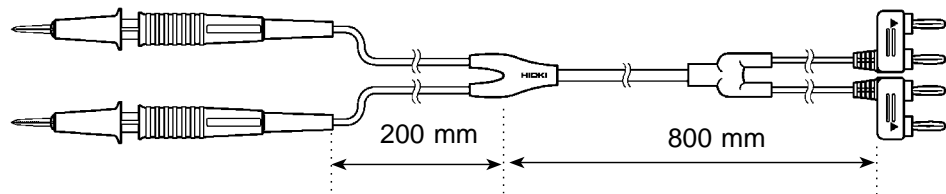

11.4.6 9453 FOUR TERMINAL LEAD

This is a four-terminal lead whose SOURCE terminal forms a covered clip and whose SENSE terminal forms a measurement lead probe. The 9453 FOUR TERMINAL LEAD should be used to measure the pattern resistance of the printed boards and the red and black SOURCE/SENSE terminals separately.

Distance between the connector and the branch: approx. 800 mm

Distance between the branch and the probe end: approx. 300 mm

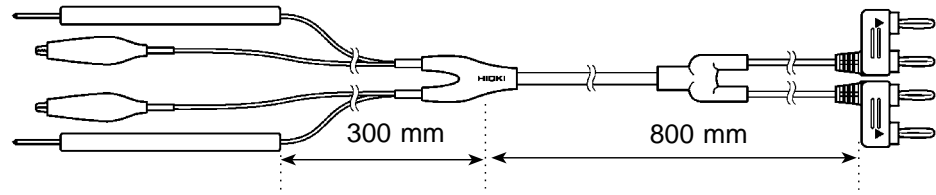

11.4.7 9455 PIN TYPE LEAD

The nose has a four-terminal structure specifically designed for examination of lifted IC leads on printed boards. This 9455 PIN TYPE LEAD is capable of accurate resistance measurements even with small objects.

Distance between the connector and the branch: approx. 400 mm

Distance between the branch and the probe end: approx. 250 mm

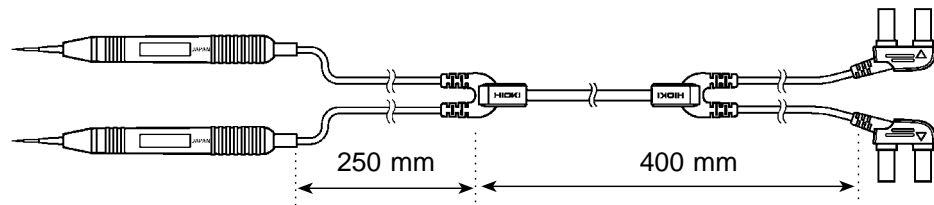

11.4.8 9461 PIN TYPE LEAD

For contact portions occurring on a flat plane unsuited to clipping, or for objects such as relay terminals and connectors, which have small contact areas, this 9461 PIN TYPE LEAD can be pressed against the object for four-terminal measurement.

Distance between the connector and the branch: approx. 400 mm

Distance between the branch and the probe: approx. 250 mm

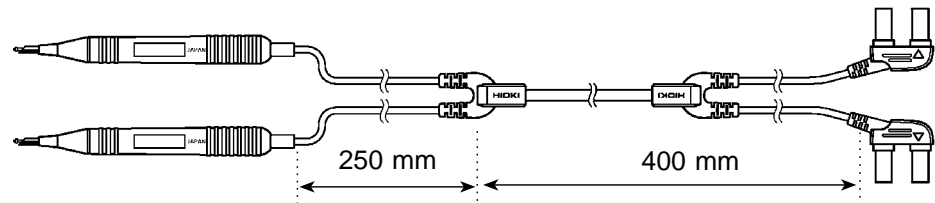

11.4.9 9467 LARGE CLIP TYPE LEAD

This 9467 PIN TYPE LEAD designed to be attached to objects having relatively thick, bar-shaped contact areas. As with 9287-10 and 9452 CLIP TYPE LEAD, four-terminal measurement is performed simply by clipping the measured object.

Distance between the connector and the branch: approx. 850 mm

Distance between the branch and the probe end: approx. 250 mm

Maximum clip diameter: approx. 29 mm

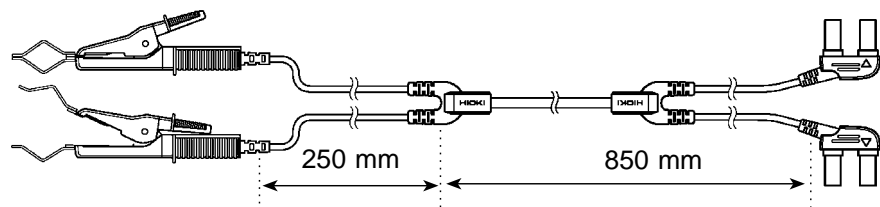

11.4.10 9454 ZERO ADJUSTMENT BOARD

The 9454 ZERO ADJUSTMENT BOARD is used to implement zero-adjust for the 9461 and 9465 PIN TYPE LEAD. Since this board has a double structure composed of printed board and steel plate, the pin-type lead can be short-circuited only by pressing the pin nose against the specified contact hole. This board is not used for the 9455 PIN TYPE LEAD.

Dimensions: approx. 214W × 24H × 8D mm



11.4.11 9466 REMOTE CONTROL SWITCH

The 9466 REMOTE CONTROL SWITCH is mounted on 9455, 9461, and 9465 PIN TYPE LEAD. This switch should be connected to the EXT.HOLD terminal on the front panel of the 3560.
Distance between the terminal and the switch: approx. 370 mm

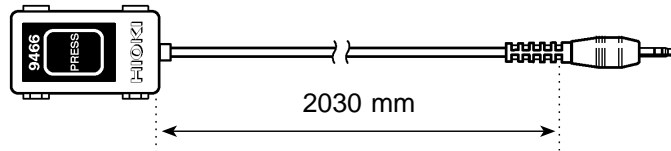

HIOKI

DECLARATION OF CONFORMITY

Manufacturer's Name: HIOKI E.E. CORPORATION
Manufacturer's Address: 81 Koizumi, Ueda, Nagano 386-1192, Japan
Product Name: AC mΩ HiTESTER
Model Number: 3560
Accessory: 9287-10 CLIP TYPE LEAD
Options: 9452 CLIP TYPE LEAD
9453 FOUR TERMINAL LEAD
9455 PIN TYPE LEAD
9461 PIN TYPE LEAD
9465 PIN TYPE LEAD
9466 REMOTE CONTROL SWITCH
9467 LARGE CLIP TYPE LEAD
9588 GP-IB INTERFACE
9589 PRINTER INTERFACE
9151-02 GP-IB CONNECTOR CABLE
9151-04 GP-IB CONNECTOR CABLE
9203 DIGITAL PRINTER
9425 CONNECTION CABLE
9233 RECORDING PAPER
9454 ZERO ADJUSTMENT BOARD

The above mentioned products conform to the following product specifications:

Safety: EN61010-1:2001
EMC: EN61326:1997+A1:1998+A2:2001+A3:2003
Class B equipment
Minimum immunity test requirement
EN61000-3-2:2000
EN61000-3-3:1995+A1:2001

Supplementary Information:

The products herewith comply with the requirements of the Low Voltage Directive 73/23/EEC and the EMC Directive 89/336/EEC.

HIOKI E.E. CORPORATION

15 September 2006

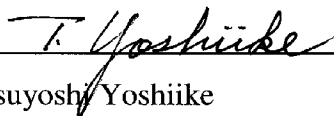
Tatsuyoshi Yoshiike
President

3560A999-04

HIOKI

INSTRUCTION MANUAL

3560

AC mΩ HiTESTER

HIOKI E. E. CORPORATION

HIOKI 3560 AC mΩ HiTESTER

Instruction Manual

Publication date: September 2006 Revised edition 7

Edited and published by HIOKI E.E. CORPORATION
Technical Support Section

All inquiries to International Sales and Marketing Department

81 Koizumi, Ueda, Nagano, 386-1192, Japan

TEL: +81-268-28-0562 / FAX: +81-268-28-0568

E-mail: os-com@hioki.co.jp

URL <http://www.hioki.co.jp/>

Printed in Japan 3560A981-07

-
-
- All reasonable care has been taken in the production of this manual, but if you find any points which are unclear or in error, please contact your supplier or the International Sales and Marketing Department at HIOKI headquarters.
 - In the interests of product development, the contents of this manual are subject to revision without prior notice.
 - Unauthorized reproduction or copying of this manual is prohibited.
-
-

HIOKI

HIOKI E. E. CORPORATION

HEAD OFFICE

81 Koizumi, Ueda, Nagano 386-1192, Japan
TEL +81-268-28-0562 / FAX +81-268-28-0568
E-mail: os-com@hioki.co.jp / URL <http://www.hioki.co.jp/>

HIOKI USA CORPORATION

6 Corporate Drive, Cranbury, NJ 08512, USA
TEL +1-609-409-9109 / FAX +1-609-409-9108

3560A981-07 06-09H



Printed on recycled paper

T  **USA**
Equipment
.NET™
1-877-742-TEST (8378)