

New

C HiTESTER 3506, 3505 C HiTESTER 3504-60, 3504-50, 3504-40

Electronic measuring instruments



For Low Capacitance

C HiTESTER 3506

Measures at 1 kHz and 1 MHz

C HiTESTER 3505

Measures at 1 kHz, 100 kHz and 1 MHz

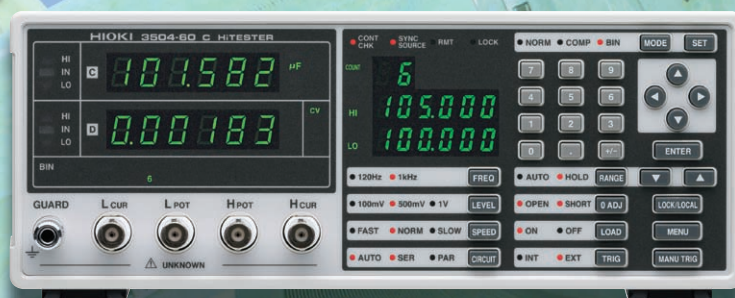

For High Capacitance MLCCs

C HiTESTERs 3504-60, 3504-50 and 3504-40

Measures at 120 Hz and 1 kHz

Ideal C meters for sorting and testing

High-Speed Measurements

Measurement intervals as fast as 2 ms

Specifically, the 3504 Series performs constant-voltage measurements of high-capacitance MLCCs in 2 ms.

High Accuracy

Models 3505 and 3506 have greatly improved repeatability accuracy for very low capacitance measurements.

Contact-Checking Functions

Use Low-C Reject and Detection Level Monitoring functions to verify contact integrity between measurement electrodes and objects to be measured.

Model 3504-60 provides four-terminal contact checking.



ISO 9001
JMI-0216



ISO 14001
JQA-E-90091



Sort values with the Bin function Measurements as fast as 2 ms

Common Features of Models 3506, 3505, 3504-60, 3504-50 and 3504-40

■ C-Meter measurement frequencies comply with JIS C 5101-1

Capacitor Type	C Range	Measurement Frequency [Hz]		Supporting Models
		● Indicates recommended frequency		
Non-Electrolytic	$C \leq 1000 \text{ pF}$	100k ○	1M ●	3506 ^(*) 3505
	$1000 \text{ pF} < C \leq 10 \text{ }\mu\text{F}$	1k ●		
	$10 \text{ }\mu\text{F} < C$	120 ●		3504-60 3504-50 3504-40
Electrolytic	-	120 ○		3511-50 (for ref.)

(*) 100 kHz not available in Model 3506

■ BIN function^{*1}

C measurement values can be classified into up to 14^{*2} ranks for easy sorting.

^{*1} Available in Models 3504-60 and 3504-50, but not in Model 3504-40.

^{*2} Models 3506 and 3505 support up to 13 ranks.

■ Comparator function

Upper and lower limits can be specified for first (C) and second (D) parameters. Evaluation results can be indicated by beeper, LED indicators and external output, with the setting values always displayed.

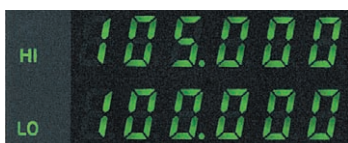

■ Memory function

Measurement data is stored in the instrument and can be downloaded via GP-IB or RS-232C.

3505, and 3506 1,000 measurements

3504-60, 3504-50 and 3504-40 32,000 measurements

■ Intuitive operation with LED indicators

Simply select the desired operation on the front panel. The current measurement configuration settings are indicated by LEDs so you can check your settings at a glance.

■ Trigger-synchronous output

The measurement signal is applied to the test sample only when a measurement trigger is applied. Because large current does not flow when making and breaking contact with the sample, contact point wear is minimized.

■ Stores 99^{*3} measurement configurations

Store up to 99 sets of measurement configuration settings for quick recall when switching test sample types on lines with many repeating measurements.

Any measurement configuration can be recalled by EXT I/O.

^{*3} Models 3506 and 3505 store up to 70 measurement configurations.

■ Contact-checking functions included

Detect contact errors during measurement.

Improve yield rates by separately managing samples that exhibit contact errors.

High-speed measurements as fast as 2 ms (1 ms for analog measurements)

High-speed testing such as with taping machines is supported by the 2 ms minimum measurement time (except FAST 120 Hz measurements). Select from FAST, NORMAL and SLOW measurement speeds.

3506, 3505		Measurement Speed		
Measurement Frequency	Output Signal	FAST	NORMAL	SLOW
1 kHz 100 kHz 1 MHz	INDEX	1.1 ms	4.1 ms	13.3 ms
	EOM	2 ms	5 ms	14 ms

3504-60, 3504-50, 3504-40		Measurement Speed		
Measurement Frequency	Output Signal	FAST	NORMAL	SLOW
120 Hz	INDEX	8.3 ms	33.3 ms	133.3 ms
	EOM	10 ms	37.5 ms	146 ms
1 kHz	INDEX	1 ms	4 ms	24 ms
	EOM	2 ms	5.5 ms	29.5 ms

Equipped with standard EXT I/O, RS-232C, and GP-IB* * GP-IB is not available on Model 3504-40.

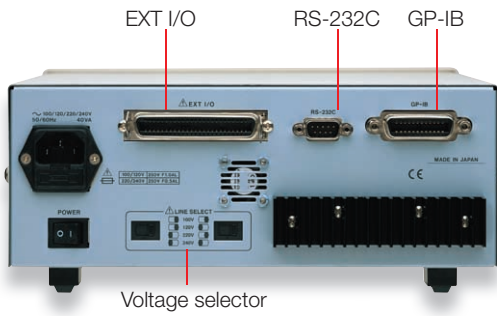

C HiTESTER 3506, 3505

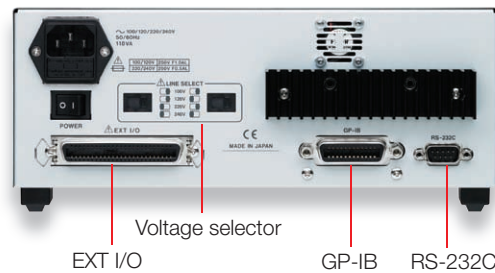

* Model 3504-40 does not include a GP-IB interface.
C HiTESTER 3504-60, 3504-50, 3504-40

EXT I/O

Triggering and loading of measurement conditions can be controlled externally. Capable of external output of comparator results, BIN measurement results, and end-of-measurement signals, these HiTESTERS support full interfacing with automated devices.

EXT I/O Features	
<ul style="list-style-type: none"> Inputs External DC power input (+5 to 24 V, may be supplied from external device) External trigger signal Panel number (Measurement configuration) selection Panel-number-valid signal Calibration 	<ul style="list-style-type: none"> Outputs Internal DC power output (+5 V) Comparator result output (first and second parameters, and ANDed results) Bin measurement judgment output Analog End-of-Measurement signal End-of-Measurement signal Error message output

RS-232C and GP-IB interface*

Except for turning the instrument's power on and off, all HiTESTER functions can be controlled from a computer. This facilitates efficient data handling when controlling or processing data in batches on a computer or when setting instrument processing or measurement conditions.

* GP-IB is not available on Model 3504-40.

EXT I/O Timing Chart

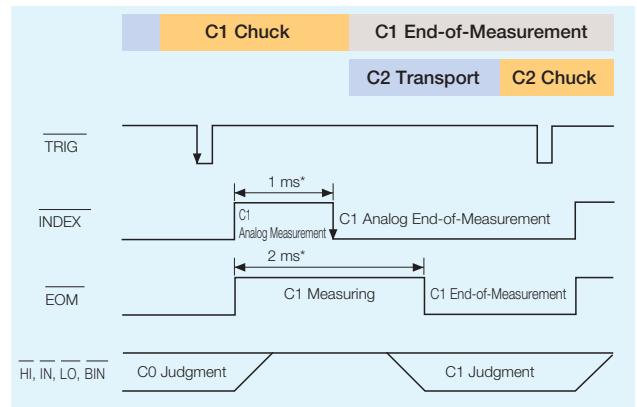

* Measurement Speed: FAST used for example. Not applicable for 120 Hz measurements.

RS-232C interface	
<ul style="list-style-type: none"> Transfer method: Start-stop transfer Data length: 8 bits Stop bit: 1 bit 	<ul style="list-style-type: none"> Transfer speed: 9600, 19200 bps Parity: None Delimiter: CR+LF, CR
GP-IB interface	
<ul style="list-style-type: none"> IEEE-488-2 1987 common commands (mandatory) can be used Conformance standard: IEEE-488.1 1987 Reference standard: IEEE-488.2 1987 	

C HiTESTER 3506, 3505

Measure low-magnitude capacitors with high accuracy



● Measurement parameters and frequency ranges

	Range of Measurements (C, D)	Measurement Frequencies			
		120 Hz	1 kHz	100 kHz	1 MHz
3506	C: 0.000 fF to 15.0000 μF D: 0.00001 to 1.99999	-	○	-	○
3505	C: 0.000 fF to 15.0000 μF D: 0.00001 to 1.99999	-	○	○	○

Features of Models 3506 and 3505 C HiTESTERS

■ Enhanced repeat-measurement accuracy

The lowest capacitance range of Models 3506 and 3505 is 220 fF* (at 1 MHz), with greatly improved repeatability accuracy for very low-capacitance measurements.
* 1 fF (femtofarad) = 10⁻¹⁵ F

■ Enhanced absolute accuracy

A self-calibration function minimizes variations in measurement values due to changes in ambient temperature. In addition, the cable-length-compensation function minimizes measurement errors when the measurement cable is extended from 1 to 2 meters (using 1.5D-2V cable).

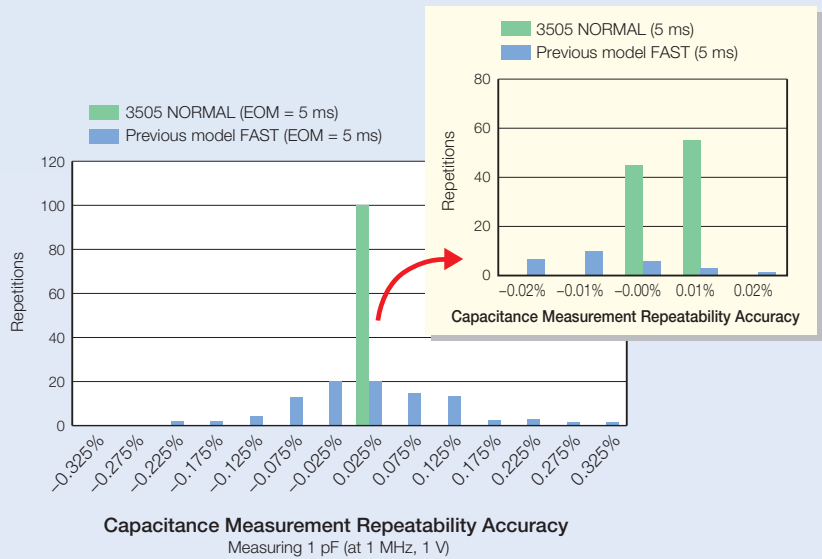

■ Enhanced contact-checking function

Contact errors while measuring can be detected by the Chatter Detection function, Low-C Reject function, Current Detection Circuit Monitoring function and the Applied Voltage Value Monitoring function. Yield rates are improved by judging measurement-object contact errors as ERR instead of FAIL.

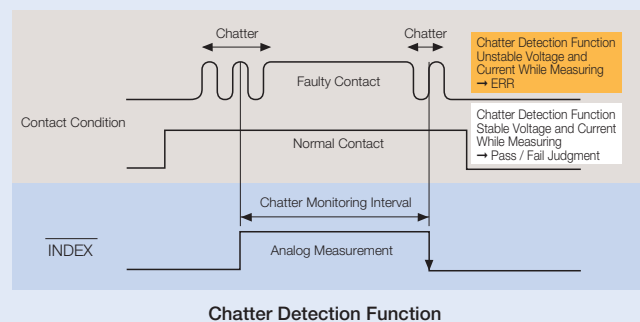
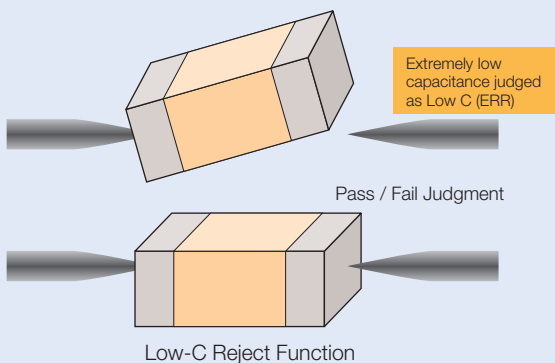

■ Specifications

Measured parameters	C (Capacitance), D (dissipation factor tan δ), Q (1/tan δ)
Measurement frequencies	1 kHz, 100 kHz (only Model 3505) and 1 MHz Accuracy: ±0.01% or better Frequency shift: 1 MHz ±1%, ±2%
Measurement signal level	Open-circuit terminal voltage: 500 mV or 1 V Signal level accuracy: ±10% ±5 mV Output resistance: Approx. 1Ω (@1 kHz in 2.2 μF and higher ranges; @100 kHz in the 22 nF and higher ranges), approx. 20 Ω (in ranges other than the above)
Range of measureable values	C: 0.000 fF to 15.0000 μF D: 0.00001 to 1.99999 Q: 0.0 to 19999.9
Equivalent circuit mode	Series-Parallel Equivalent Circuit mode (Auto/Manual)
Measurement time	Representative value: 2 ms (FAST) (Actual measurement time depends on measurement configuration settings)
Measurement speed	FAST, NORMAL and SLOW
Averaging function	1 to 256
Low-C Reject function	Bad Contact Detection (open circuit between terminals)
Chatter Detection function	Bad Contact Detection (chatter)
Current Detection Circuit Monitoring function	A measurement signal fault is detected when external noise causes measurement levels to be out of tolerance for the measurement range.
Applied Voltage Value Monitoring function	An error is detected when voltage monitored across a test sample is outside of the judgment standard.
Trigger function	Internal and external triggers can be enabled
Trigger Delay	0 to 9.999 s
Memory function	Up to 1,000 measurement values can be stored in the instrument (Downloadable by GP-IB and RS-232C)

Compensation	Open- and short-circuit compensation, load and cable length compensation, and self calibration
Trigger-synchronous output function	Functions to inhibit measurement voltage except while actually measuring
Key-lock function	Settings can be made and cancelled by front panel keys
BIN measurement	C: 13 ranks, D-NG, OUT OF BINS, Absolute value setting, Δ setting, Δ% setting
Comparator	C: HI, IN, LO; D(Q): HI, IN, LO Absolute value setting, Δ setting, Δ% setting
Panel save and load	70 setting configurations can be stored Load method: key operation or external I/O
Audible beeper	Setting the buzzer for comparator judgment results (IN or NG) to ON or OFF is possible
Interface	RS-232C, GP-IB and EXT I/O (included as standard)
Printer function	Measurement values can be printed (requires Model 9442 or 9444 cable)
Display device	LEDs (on/off)
Operating temperature and humidity	0 to 40°C, 80% RH or less (non-condensating)
Storage temperature and humidity	-10 to 55°C, 80% RH or less (non-condensating)
Operating environment	Indoors, to 2000 m ASL
Power supply	Selectable 100, 120, 220 or 240 V ±10%, 50/60 Hz
Max. power consumption	40 VA
Withstand voltage	Power line to ground: 1.39 kV AC for 15 s
Backup battery life	Approx. 6 years
Dimensions	Approx. 260 W × 100 H × 298 D mm (exc. projections)
Weight	Approx. 4.8 kg
Applicable standards	EMC: EN61326, EN61000-3-2, EN61000-3-3 Safety: EN61010-1
Supplied accessories	Power Cord, Spare Fuse

Measurement accuracy and range Temp. and humidity for guaranteed accuracy: 23°C ±5%, 80% RH or less (non-condensating)
Warm-up time: 1 h, with open- and short-circuit compensation, and self calibration set to Auto

■ Measurement area: C: 0.001 fF to 15.0000 μF; D: 0.00001 to 1.99999

■ Measurement accuracy

Use the following equation to calculate the measurement accuracy.

Measurement accuracy = basic accuracy × B × C × D × E

[B: Measurement signal level coefficient]
1 V: 1, 500 mV: 2

[C: Measurement speed coefficient]
FAST: 1.5, NORMAL: 1.2, SLOW: 1

[D: Cable length coefficient] (using 1.5D-2V cable)
0 m: 1, 1 m: 1.5, 2 m: 2

[E: Temperature coefficient]
1 + 0.1 × |t - 23|
t = operating temperature (°C)

■ Basic accuracy [Guaranteed accuracy: 6 months when D ≤ 0.1 D]

C range	Parameter	Accuracy		C range	Parameter	Accuracy		C range	Parameter	Accuracy	
		1 kHz				100 kHz (only Model 3505)				1 MHz	
100 pF	C	0.12%rdg+0.2%rdg×(Cr/Cx)		1 pF	C	0.5%rdg+0.5%rdg×(Cr/Cx)		220 fF	C	0.2%rdg+1%rdg×(Cr/Cx)	
	D	0.002+0.001×(Cr/Cx)			D	0.004+0.004×(Cr/Cx)			D	0.004+0.002×(Cr/Cx)	
220 pF	C	0.12%rdg+0.08%rdg×(Cr/Cx)		2.2 pF	C	0.3%rdg+0.2%rdg×(Cr/Cx)		470 fF	C	0.15%rdg+0.3%rdg×(Cr/Cx)	
	D	0.0012+0.0004×(Cr/Cx)			D	0.004+0.003×(Cr/Cx)			D	0.003+0.001×(Cr/Cx)	
470 pF	C	0.12%rdg+0.04%rdg×(Cr/Cx)		4.7 pF	C	0.25%rdg+0.15%rdg×(Cr/Cx)		1 pF	C	0.12%rdg+0.16%rdg×(Cr/Cx)	
	D	0.0012+0.0003×(Cr/Cx)			D	0.004+0.002×(Cr/Cx)			D	0.002+0.001×(Cr/Cx)	
1 nF	C	0.12%rdg+0.02%rdg×(Cr/Cx)		10 pF	C	0.25%rdg+0.1%rdg×(Cr/Cx)		2.2 pF	C	0.12%rdg+0.08%rdg×(Cr/Cx)	
	D	0.0012+0.0003×(Cr/Cx)			D	0.004+0.002×(Cr/Cx)			D	0.0012+0.0004×(Cr/Cx)	
2.2 nF	C	0.12%rdg+0.02%rdg×(Cr/Cx)		22 pF	C	0.25%rdg+0.06%rdg×(Cr/Cx)		4.7 pF	C	0.12%rdg+0.04%rdg×(Cr/Cx)	
	D	0.0012+0.0003×(Cr/Cx)			D	0.003+0.0015×(Cr/Cx)			D	0.0012+0.0003×(Cr/Cx)	
4.7 nF	C	0.12%rdg+0.02%rdg×(Cr/Cx)		47 pF	C	0.25%rdg+0.06%rdg×(Cr/Cx)		10 pF	C	0.12%rdg+0.02%rdg×(Cr/Cx)	
	D	0.001+0.0003×(Cr/Cx)			D	0.0025+0.0015×(Cr/Cx)			D	0.0012+0.0003×(Cr/Cx)	
10 nF	C	0.12%rdg+0.02%rdg×(Cr/Cx)		100 pF	C	0.15%rdg+0.06%rdg×(Cr/Cx)		22 pF	C	0.12%rdg+0.02%rdg×(Cr/Cx)	
	D	0.001+0.0003×(Cr/Cx)			D	0.0015+0.001×(Cr/Cx)			D	0.001+0.0003×(Cr/Cx)	
22 nF	C	0.12%rdg+0.02%rdg×(Cr/Cx)		220 pF	C	0.15%rdg+0.04%rdg×(Cr/Cx)		47 pF	C	0.12%rdg+0.02%rdg×(Cr/Cx)	
	D	0.001+0.0003×(Cr/Cx)			D	0.0015+0.0005×(Cr/Cx)			D	0.001+0.0003×(Cr/Cx)	
47 nF	C	0.12%rdg+0.02%rdg×(Cr/Cx)		470 pF	C	0.15%rdg+0.02%rdg×(Cr/Cx)		100 pF	C	0.12%rdg+0.02%rdg×(Cr/Cx)	
	D	0.001+0.0003×(Cr/Cx)			D	0.0015+0.0003×(Cr/Cx)			D	0.001+0.0003×(Cr/Cx)	
100 nF	C	0.12%rdg+0.02%rdg×(Cr/Cx)		1 nF	C	0.15%rdg+0.02%rdg×(Cr/Cx)		220 pF	C	0.12%rdg+0.02%rdg×(Cr/Cx)	
	D	0.001+0.0003×(Cr/Cx)			D	0.0015+0.0003×(Cr/Cx)			D	0.001+0.0003×(Cr/Cx)	
220 nF	C	0.12%rdg+0.02%rdg×(Cr/Cx)		2.2 nF	C	0.15%rdg+0.02%rdg×(Cr/Cx)		470 pF	C	0.12%rdg+0.02%rdg×(Cr/Cx)	
	D	0.001+0.0003×(Cr/Cx)			D	0.0015+0.0003×(Cr/Cx)			D	0.001+0.0003×(Cr/Cx)	
470 nF	C	0.12%rdg+0.02%rdg×(Cr/Cx)		4.7 nF	C	0.15%rdg+0.02%rdg×(Cr/Cx)		1 nF	C	0.12%rdg+0.02%rdg×(Cr/Cx)	
	D	0.001+0.0003×(Cr/Cx)			D	0.0015+0.0003×(Cr/Cx)			D	0.001+0.0003×(Cr/Cx)	
1 μF	C	0.12%rdg+0.02%rdg×(Cr/Cx)		10 nF	C	0.15%rdg+0.02%rdg×(Cr/Cx)		10 nF	C	0.15%rdg+0.02%rdg×(Cr/Cx)	
	D	0.001+0.0003×(Cr/Cx)			D	0.0015+0.0003×(Cr/Cx)			D	0.0015+0.0003×(Cr/Cx)	
2.2 μF	C	0.12%rdg+0.02%rdg×(Cr/Cx)		22 nF	C	0.15%rdg+0.02%rdg×(Cr/Cx)		22 nF	C	0.15%rdg+0.02%rdg×(Cr/Cx)	
	D	0.001+0.0003×(Cr/Cx)			D	0.0015+0.0003×(Cr/Cx)			D	0.0015+0.0003×(Cr/Cx)	
4.7 μF	C	0.12%rdg+0.02%rdg×(Cr/Cx)		47 nF	C	0.15%rdg+0.02%rdg×(Cr/Cx)		47 nF	C	0.15%rdg+0.02%rdg×(Cr/Cx)	
	D	0.001+0.0003×(Cr/Cx)			D	0.0015+0.0003×(Cr/Cx)			D	0.0015+0.0003×(Cr/Cx)	
10 μF	C	0.12%rdg+0.02%rdg×(Cr/Cx)		100 nF	C	0.2%rdg+0.02%rdg×(Cr/Cx)		100 nF	C	0.2%rdg+0.02%rdg×(Cr/Cx)	
	D	0.001+0.0003×(Cr/Cx)			D	0.002+0.0003×(Cr/Cx)			D	0.002+0.0003×(Cr/Cx)	

[Cx : the electrical capacity of the sample / Cr : the electrical capacity of the measurement range]

C HiTESTER 3504-60, 3504-50 and 3504-40

Perform high-speed, constant-voltage testing even of high-capacitance MLCs



● Measurement parameters and frequency ranges

	Range of Measurements (C, D)	Measurement Frequencies			
		120 Hz	1 kHz	100 kHz	1 MHz
3504-60	C: 0.9400 pF to 20.0000 mF D: 0.00001 to 1.99999	○	○	-	-
3504-50		○	○	-	-
3504-40		○	○	-	-

● Functional differences between Models 3504-60, 3504-50 and 3504-40

	Constant-Voltage Measurement (CV)			Four-Terminal Contact Check Function	Bin Function	Interface		
	100mV	500mV	1V			RS-232C	GP-IB	EXT I/O
3504-60	○	○	○	○	○	○	○	○
3504-50	-	○	○	-	○	○	○	○
3504-40	-	○	○	-	-	○	-	○

Features of Model 3504-60, 3504-50 and 3504-40 C HiTESTERS

■ Constant voltage measurement (CV)

Constant measuring voltages of 1 V, 500 mV and 100 mV*¹ are provided for voltage-dependent capacitance measurements. Measurement frequency is selectable from 120 Hz or 1 kHz.

*1 100 mV in Model 3504-60 only.

■ Compatible with taping machine assemblies

Model 3504-40 provides the speed and good cost-performance suitable for taping machine systems.

■ Four-Terminal Contact-Checking Function*²

Detect contact errors at all four measurement terminals, for highly reliable contact checking.

*2 Model 3504-60.

■ Enhanced Contact-Checking Functions

Contact errors can be detected while measuring by the Low-C Reject and Chatter Detection functions.

Yield rates are improved by judging measurement object contact errors as ERR instead of FAIL.

■ Specifications

Measured parameters	C (capacitance), D (dissipation factor tan δ)
Measurement frequencies	120 Hz or 1 kHz Accuracy: ±0.01% or better
Measurement signal level	(1) Constant voltage mode: 100 mV* ¹ , 500 mV and 1 V CV 1V measurement ranges: up to 70 μF range (1 kHz) up to 0.7 mF range (120 Hz) CV100 mV* ¹ , CV 500 mV measurement ranges: up to 170 μF range (1 kHz) up to 1.45 mF range (120 Hz) Signal level accuracy: ±10% ±5 mV (2) Open terminal voltage mode: 100 mV* ¹ , 500 mV and 1 V Measurement range: Other than the above Output resistance: approx. 5Ω Signal level accuracy: ±10% ±5 mV
*1 100 mV in Model 3504-60 only	
Range of measurable values	C: 0.9400 pF to 20.0000 mF D: 0.00001 to 1.99999
Equivalent circuit mode	Series/parallel equivalent-circuit mode (Auto/Manual)
Measurement time	Nominal 2 ms (1 kHz, FAST) (The measurement time differs depending on the measurement frequency and measurement speed that are set.)
Measurement speed	FAST / NORMAL / SLOW
Trigger function	Internal and external trigger sources can be selected.
Trigger delay	0 to 9.999 s (at 0.001 s resolution)
Compensation	Open, Short, Load and Offset compensation, Self-calibrating
Averaging function	1 to 256
Four-terminal contact-checking function* (* 3504-60 only)	Detects contact anomalies (open state in four-terminal measurements)
Low-C Reject function	Detects contact anomalies (open state in two-terminal measurements)
Chatter Detection function	Detects contact bounce (chatter)

Trigger-synchronous output function	Function to apply a measurement signal only when performing measurement.
Key-lock function	The key lock can be set and cancelled by key operation on the front panel
BIN measurement (Not available on the 3504-40)	C: 14 ranks, D-NG, OUT OF BINS Absolute value setting, Δ% setting
Memory function	Up to 32,000 measurement values can be stored in the instrument (Downloadable by GP-IB and RS-232C)
Comparator	C: HI / IN / LO, D: HI / IN / LO Absolute value setting, Δ% setting
Panel save and load	Up to 99 sets of measurement conditions can be saved. Load method: Key operation, external I/O.
Audible beeper	The beeper can be set on or off according to the comparator evaluation result ("IN" or "NG") and Bin decision result.
Interface	Models 3504-50, 3504-60: RS-232C, GP-IB, EXT I/O (standard) Model 3504-40: RS-232C, EXT I/O (standard)
Printer function	Measurement values can be printed (requires Printer 9442 and optional Connection Cable 9444)
Display device	LED
Operating temperature and humidity	0 to 40°C, 80% RH or less (no condensation)
Storage temperature and humidity	-10 to 55°C, 80% RH or less (no condensation)
Operating environment	Indoors, up to 2000 m ASL
Power supply	AC 100 V, 120 V, 220 V, or 240 V±10% (selectable), 50/60 Hz
Max. power consumption	110 VA max.
Withstand voltage	Power line to ground, AC 1.69 kV, 15 sec.
Backup battery life	Approx. 6 years
Dimensions	Approx. 260 (W) × 100 (H) × 220 (D) mm (excluding protrusions)
Weight	Approx. 3.8 kg
Applicable standards	EMC: EN61326, EN61000-3-2, EN61000-3-3 Safety: EN61010-1
Supplied accessories	Power cord, spare fuse

C HiTESTER 3504-60, 3504-50 and 3504-40

Measurement accuracy and range

Temp. and humidity for guaranteed accuracy: 23°C ±5%, 80% RH or less (non-condensating)
Warm-up time: 1 h, with open- and short-circuit compensation

■ **Measurement area:** C: 0.9400 pF to 20.0000 mF; D: 0.00001 to 1.99999

Measurement accuracy

Use the following equation to calculate the measurement accuracy.

$$\text{Measurement accuracy} = \text{basic accuracy} \times B \times C \times D \times E$$

[B: Measurement signal level coefficient]
1 at 1 V and at 500 mV,
1.5 at 100 mV

[C: Measurement speed coefficient]

FAST: 1.5

NORMAL: 1.0 (at 1 kHz, 1 V),
1.2 (except at 1 kHz, 1 V)

SLOW: 1

[D: Cable length coefficient] (using 1.5C-2V cable)

0 m: 1

1 m: 1 (at 1 kHz, 1 V)

1.5 (except at 1 kHz, 1 V)

[E: Temperature coefficient]

$1 + 0.1 \times t - 23$

t = operating temperature (°C)

Basic accuracy [Guaranteed accuracy: 6 months when $D \leq 0.1 D$]

Range No.	C range		Parameter	Basic accuracy *1		CV operation
	120 Hz	1 kHz		120 Hz	1 kHz	
1	200 pF	20 pF	C	$\pm 0.20\% \text{rdg} \pm 300 \text{dgt.}$	$\pm 0.20\% \text{rdg} \pm 300 \text{dgt.}$	○
			D	$\pm 0.0120 \pm 2/\text{Cl}$	$\pm 0.0120 \pm 0.25/\text{Cl}$	○
2	2 nF	200 pF	C	$\pm 0.20\% \text{rdg} \pm 60 \text{dgt.}$	$\pm 0.20\% \text{rdg} \pm 60 \text{dgt.}$	○
			D	$\pm 0.0020 \pm 2.2/\text{Cl}$	$\pm 0.0020 \pm 0.265/\text{Cl}$	○
3	20 nF	2 nF	C	$\pm 0.16\% \text{rdg} \pm 20 \text{dgt.}$	$\pm 0.14\% \text{rdg} \pm 20 \text{dgt.}$	○
			D	± 0.0036	± 0.0036	○
4	200 nF	20 nF	C	$\pm 0.15\% \text{rdg} \pm 15 \text{dgt.}$	$\pm 0.13\% \text{rdg} \pm 15 \text{dgt.}$	○
			D	± 0.0020	± 0.0020	○
5	2 μF	200 nF	C	$\pm 0.15\% \text{rdg} \pm 15 \text{dgt.}$	$\pm 0.13\% \text{rdg} \pm 15 \text{dgt.}$	○
			D	± 0.0016	± 0.0016	○
6	20 μF	2 μF	C	$\pm 0.15\% \text{rdg} \pm 15 \text{dgt.}$	$\pm 0.09\% \text{rdg} \pm 10 \text{dgt.}$	○
			D	± 0.0020	± 0.0016	○
7	200 μF	20 μF	C	$\pm 0.25\% \text{rdg} \pm 20 \text{dgt.}$	$\pm 0.13\% \text{rdg} \pm 15 \text{dgt.}$	○
			D	± 0.0035	± 0.0030	○
8	0.7 mF(1V) 1.45 mF(500 mV, 100 mV)	70 μF(1V) 170 μF(500 mV, 100 mV)	C	$\pm 1.2\% \text{rdg} \pm 50 \text{dgt.}$	$\pm 0.7\% \text{rdg} \pm 40 \text{dgt.}$	○
	D	± 0.0060	± 0.0050	○		
9	2 mF	200 μF	C	$\pm 1.2\% \text{rdg} \pm 50 \text{dgt.}$	$\pm 0.7\% \text{rdg} \pm 40 \text{dgt.}$	×
			D	± 0.0060	± 0.0050	×
10	20 mF	2 mF	C	$\pm 2.5\% \text{rdg} \pm 50 \text{dgt.}$	$\pm 2.0\% \text{rdg} \pm 40 \text{dgt.}$	×
			D	$\pm 0.0200 \pm 0.008 \times \text{CH}$	$\pm 0.0180 \pm 0.08 \times \text{CH}$	×

[Cl: Capacitance of component (pF), CH: Capacitance of component (mF)]

*1 Accuracy of range nos. 1 and 2 are not guaranteed at 100 mV measurement signal level.

LCR meter for electrolytic capacitors

LCR HiTESTER 3511-50 CE



- High speed measurement: 5 ms (1 kHz) or 13 ms (120 Hz)
- Built-in high-speed comparator function ideal for measuring at the production line
- Source frequency: 120 Hz or 1 kHz
- Print measurement values and judgment results with the optional Printer 9442

Measurement leads are not included. Purchase the appropriate lead option for your application separately.

Resistance tester for continuity testing of 3 terminal capacitors

RESISTANCE HiTESTER 3541 CE



- **Wide Measurement Range**
0.1 μΩ (20 mΩ ranges) to 110.000 MΩ
- **High Speed & High Precision Measurements**
As fast as 0.6 ms with 70 ppm precision (in the 2 kΩ to 110 kΩ range)
- **Two types of Temperature Correction**
Correction by Pt sensor or Infrared Thermometer
- **Low-Power Measurement Function**
Essential for DCR measurements of chip inductors and connector contacts
- **Equipped with EXT I/O, GP-IB and RS-232C interfaces**
Easily integrates into automated production lines
- **Data Printing**
Print out measurement values and calculation results (with optional Printer 9670)

Options for a wide range of applications

• For 3504-60, 3504-50 and 3504-40

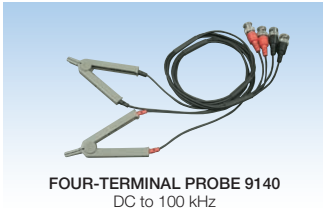

FOUR-TERMINAL PROBE 9140
DC to 100 kHz



PINCHER PROBE 9143
DC to 5 MHz



TEST FIXTURE 9261
DC to 5 MHz

* 9140, 9143, 9261 cable lengths are 1 m (39.37").

• For 3506, 3505, 3504-60, 3504-50 and 3504-40



TEST FIXTURE 9262
DC to 5 MHz



SMD TEST FIXTURE 9263
DC to 5 MHz
Test sample dimensions: 1 to 10 mm



SMD TEST FIXTURE 9677
DC to 120 MHz
Test sample dimensions: 3.5 ± 0.5 mm



SMD TEST FIXTURE 9699
DC to 120 MHz
Test sample dimensions: 1.0 to 4.0 mm wide, maximum 1.5 mm high

PRINTER 9442



(The optional Connection Cable 9444 and AC Adapter are required to connect the Printer 9442.)

Measurement values, comparator results, and BIN measurement results can be printed out on the optional Printer 9442 via the standard RS-232C interface. This is convenient if you want to attach inspection results to printed data.

■ Printer 9442 specifications

- Printing method: Thermal serial dot printer
- Paper width: 112 mm
- Print speed: 52.5 cps
- Power supply: AC Adapter 9443 or supplied NiMH battery (prints 3000 lines after full charge using 9443)
- Dimensions and weight: Approx. 160 (W) × 66.5 (H) × 170 (D) mm, 580 g

Print sample

C	198.416n	F	D	0.00173		
C	198.414n	F	D	0.00171		
C	198.410n	F	D	0.00174		
C	198.420n	F	D	0.00347		
C	198.391n	F	L0	D	0.00527	HI
C	198.389n	F	L0	D	0.00344	IN
C	198.403n	F	IN	D	0.00175	IN
C	198.389n	F	L0	D	0.00521	HI
C	198.395n	F	L0	D	0.00345	IN
C	198.395n	F	L0	D	0.00523	HI

■ Ordering information

For Low-Magnitude Capacitors

C HiTESTER 3505

(Measurement frequencies: 1 kHz, 100 kHz and 1 MHz)

C HiTESTER 3506

(Measurement frequencies: 1 kHz and 1 MHz)

For High-Magnitude MLCC

C HiTESTER 3504-60

(Measurement frequencies: 120 Hz and 1 kHz, four-terminal contact-checking function, constant voltage measurement at 100 mV, 500 mV and 1 V)

C HiTESTER 3504-50

(Measurement frequencies: 120 Hz and 1 kHz constant voltage measurement at 500 mV and 1 V)

C HiTESTER 3504-40

(Measurement frequencies: 120 Hz and 1 kHz constant voltage measurement at 500 mV and 1 V, no GP-IB interface, no Bin function)

Probe and test fixtures are not supplied with the unit. Select an optional probe and test fixture when ordering.

• Optional accessories

FOUR-TERMINAL PROBE **9140**

PINCHER PROBE **9143**

TEST FIXTURE **9261**

TEST FIXTURE **9262** (direct connection type)

SMD TEST FIXTURE **9263** (direct connection type)

SMD TEST FIXTURE **9677** (direct connection type)

SMD TEST FIXTURE **9699** (direct connection type)

GP-IB CONNECTION CABLE **9151-02** (2 m/ 78.74")

GP-IB CONNECTION CABLE **9151-04** (4 m/ 157.48")

PRINTER **9442**

AC ADAPTER **9443-01** (for 9442, Japan)

AC ADAPTER **9443-02** (for 9442, EU)

AC ADAPTER **9443-03** (for 9442, USA)

CONNECTION CABLE **9444** (for 9442)

RECORDING PAPER **1196** (for 9442 / 25 m/ 984.25", 10 rolls)

HIOKI
HIOKI E. E. CORPORATION

T  **USA**
Equipment
.NET

205 Westwood Ave
Long Branch, NJ 07740
1-877-742-TEST (8378)
Fax: (732) 222-7088
salesteam@Tequipment.NET