

INSTRUCTION MANUAL

Logger Series

- 3631-20 HUMIDITY LOGGER**
- 3632-20 TEMPERATURE LOGGER**
- 3633-20 TEMPERATURE LOGGER**
- 3634-20 INSTRUMENTATION LOGGER**
- 3635-24,25,26 VOLTAGE LOGGER**

HIOKI E. E. CORPORATION

Contents

Introduction	i
Inspection	i
Safety Notes	ii
Notes on Use	v
Chapter 1 Overview	1
Chapter 2 Set Up	5
2.1 Replacing the Battery	5
2.2 Power Save Function	7
2.3 Setting Current Time	9
2.4 Connecting Sensor and Cable	10
Chapter 3 Settings	15
3.1 Setting Items	15
3.2 Manual Setting	18
3.3 Setting by COMMUNICATION BASE	20
3.4 Connecting COMMUNICATION BASE with Logger	21
Chapter 4 Specifications	23
Chapter 5 Maintenance and Service	35

Introduction

Thank you for purchasing the HIOKI 3631 to 3635 Logger Series. To obtain maximum performance from the product, please read this manual first, and keep it handy for future reference.

Inspection

When you receive the product, inspect it carefully to ensure that no damage occurred during shipping. If damage is evident, or if it fails to operate according to the specifications, contact your dealer or Hioki representative.

General accessories

Instruction Manual

LR03 alkaline battery x 2

(built into this unit, for monitor)

Designated accessory for each logger

3631-20	9630 HUMIDITY SENSOR
3634-20	9632 CONNECTION CABLE
3635-24 3635-25 3635-26	9632 CONNECTION CABLE





Safety Notes

This manual contains information and warnings essential for safe operation of the product and for maintaining it in safe operating condition. Before using the product, be sure to carefully read the following safety notes.





This product is designed to conform to IEC 61010 Safety Standards, and has been thoroughly tested for safety prior to shipment. However, mishandling during use could result in injury or death, as well as damage to the product. Be certain that you understand the instructions and precautions in the manual before use. We disclaim any responsibility for accidents or injuries not resulting directly from product defects.

Safety symbols

	<ul style="list-style-type: none"> • The  symbol printed on the product indicates that the user should refer to a corresponding topic in the manual (marked with the ) before using the relevant function. • In the manual, the  symbol indicates particularly important information that the user should read before using the product.
	<p>Indicates DC (Direct Current).</p>

The following symbols are used in this Instruction Manual to indicate the relative importance of cautions and warnings.

	<p>Indicates that incorrect operation presents a significant hazard that could result in serious injury or death to the user.</p>
	<p>Indicates that incorrect operation presents a possibility of injury to the user or damage to the product.</p>

Measurement categories (Overvoltage categories)

This product complies with CAT I safety requirements. To ensure safe operation of measurement product, IEC 61010 establishes safety standards for various electrical environments, categorized as CAT I to CAT IV, and called measurement categories. These are defined as follows.

- | | |
|---------|--|
| CAT I | Secondary electrical circuits connected to an AC electrical outlet through a transformer or similar device. |
| CAT II | Primary electrical circuits in equipment connected to an AC electrical outlet by a power cord (portable tools, household appliances, etc.) |
| CAT III | Primary electrical circuits of heavy equipment (fixed installations) connected directly to the distribution panel, and feeders from the distribution panel to outlets. |
| CAT IV | The circuit from the service drop to the service entrance, and to the power meter and primary overcurrent protection device (distribution panel). |

Higher-numbered categories correspond to electrical environments with greater momentary energy. So a measurement device designed for CAT III environments can endure greater momentary energy than a device designed for CAT II. Using a measurement product in an environment designated with a higher-numbered category than that for which the product is rated could result in a severe accident, and must be carefully avoided.

Never use a CAT I measuring product in CAT II, III, or IV environments. The measurement categories comply with the Overvoltage Categories of the IEC60664 Standards.

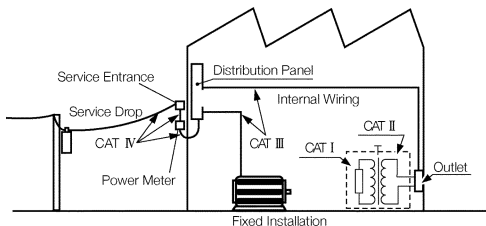

Notes on Use

Follow these precautions to ensure safe operation and to obtain the full benefits of the various functions.

⚠ CAUTION

- The unit should always be operated in a range from -20 to 70 and 80 %RH or less.
- The 9630 HUMIDITY SENSOR should be replaced every year. You are recommended to replace it twelve months after opening the package.
- If used outside the specified environmental ranges for operation (or storage), the sensor accuracy may deteriorate in less than one year, and accurate measurement may not be possible.
- If used outside the specified environmental ranges for operation (or storage), the operation of the unit cannot be guaranteed.
- When the 9630 HUMIDITY SENSOR is not being used, seal it in a plastic bag with a desiccating agent, and store in a dark, cool place.

⚠ CAUTION

- Take care to avoid condensation. In particular, if there is a sudden change of temperature (for example moving from a cold place to a warm one), condensation is likely to occur.
- To avoid damage or malfunction, avoid excessive force on the tip of the 9631 Temperature Sensor series or overly bending the leads.
- Do not dip the unit in liquids (water, alcohol, etc.).
- Avoid use in an atmosphere containing corrosive gases or the vapor of organic solvents.
- Testing monitor batteries installed in the unit may possibly be weak. Replace batteries before extended measurement usage.
- Use the original packing materials when reshipping the product, if possible.
- Use only LR03 Alkaline batteries. Using manganese batteries may not result in accurate measurements or proper communication with the Communication Base.
- Avoid directly exposing the optical communication port in the data logger to light sources powered by AC voltage such as fluorescent lighting - doing so may cause the instrument to malfunction.
Depending on the luminosity of the lighting, as much as possible stay away from the light source or cover the optical communication port when using the logger.

Chapter 1

Overview

Logger series enable measurement and recording at fixed intervals.

Data is saved in nonvolatile memory when batteries are weak or removed for replacement. Logger series products are designed for various types of recording shown below. For details, see each product specification.

3631-20	Temperature and Humidity
3632-20	Temperature (internal sensor)
3633-20	Temperature (external sensor)
3634-20	Instrumentation sensor (4-20 mA) compatible
3635	Voltage output sensor compatible 3635-24 (± 500 mVDC) 3635-25 (± 5 VDC) 3635-26 (± 50 VDC)

In use with HIOKI measurement instrument
analog output

3635-24: 3423

3635-25: 3404, 3444, 3445

Interval and Maximum Recording Time (Power save function: On)

Single 3631-20 HUMIDITY LOGGER records temperature and humidity each up to 8000 data.

INTVL	REC time	INTVL	REC time
2 s	4h26min40s	1 min	5day13h20min
5 s	11h6min40s	2 min	11day2h40min
10 s	22h13min20s	5 min	27day18h40min
15s	33h20min	10 min	55day13h20min
20 s	44h26min4s	15 min	83day8h
30 s	66h40min	20 min	111day2h40min
		30 min	166day16h
		60 min	333day8h

Using loggers other than 3631-20 HUMIDITY LOGGER, single logger records up to 16000 data.

INTVL	REC time	INTVL	REC time
2 s	8h53min20s	1 min	11day2h40min
5 s	22h13min20s	2 min	22day5h20min
10 s	44h26min40s	5 min	55day13h20min
15 s	66h40min	10 min	111day2h40min
20 s	88h53min20s	15 min	166day16h
30 s	133h20min	20 min	222day5h20min
		30 min	333day8h
		60 min	666day16h

Name and Functions of Parts

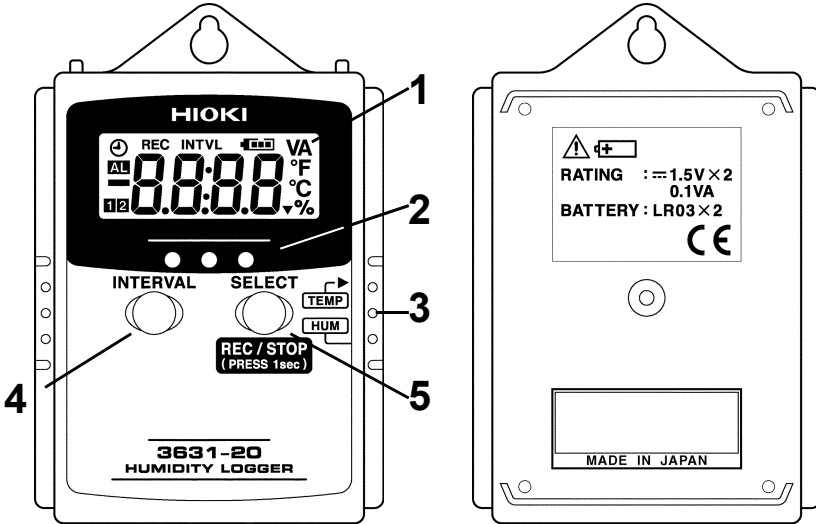

EX: 3631-20

1. LCD	Displays measurement value and settings.
2. Optical data transfer ports	Enables optical data transfer to COMMUNICATION BASE.
3. Connecting terminals	Connects various sensors and data transfer cables.
4. INTERVAL button	Calls up interval setting display to set interval.
5. SELECT button (REC/STOP)	Pressing more than 1 second initiates or stops recording. Interval is selected in interval setting display.

Chapter 2



Set Up

2.1 Replacing the Battery

**WARNING**

- To avoid electric shock when replacing the batteries, disconnect the connection cable before beginning. Also, after replacing the batteries, always replace the cover and tighten the screw before using the unit.
- Do not mix old and new batteries, or different types of batteries. Also, be careful to observe battery polarity during installation. Otherwise, poor performance or damage from battery leakage could result.
- Do not touch board when replacing batteries. Touching board may result in damage.
- Handle and dispose of batteries in accordance with local regulations.
- Use only LR03 Alkaline batteries. Using manganese batteries may not result in accurate measurements or proper communication with the Communication Base.

Installing new batteries assures operation for about two years (about one year with 3631-20). (at 20 °C temperature, power save function: on, interval set at 1 minute)

Remaining battery power indicator () indicates remaining battery life reducing incrementally from right. Empty battery power indicator () indicates time to replace batteries.

- (1)** Remove back cover screw to remove cover. Verify polarity and install two new LR03 alkaline batteries.
- (2)** Fit cover properly and tighten screw.

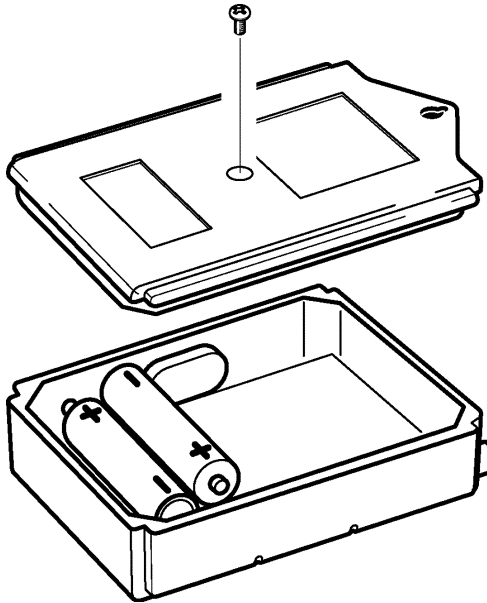

2.2 Power Save Function

Display window is automatically turned off in approximately 15 seconds after last key entry. (Sleep)

However, while recording, **REC** /  /  mark shows each conditions.

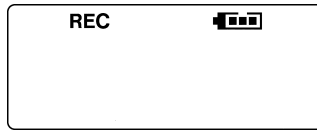

Press any button to turn display on to display measurement value or to set settings.

Note when interval setting display is on, sleep does not engage even after 15 seconds has passed with no button press.

Initially, power save function is on. To turn off power save function, follow the instructions below.

Turning off power save shortens battery life.

Setting procedure

- (1)** Connect logger, COMMUNICATION BASE and personal computer.
- (2)** Start up application software packaged with COMMUNICATION BASE.
- (3)** Go to Communications on the menu bar and select Power Save Options. Choose Off to turn off power save function.

Changing power save settings initializes all logger measurement conditions (excluding measurement data).

To connect COMMUNICATION BASE with logger and personal computer and to install application software, see COMMUNICATION BASE Instruction Manual.

To use application software, see Help.

2.3 Setting Current Time

After replacing batteries in logger series current time must be set when connecting with COMMUNICATION BASE for the first time. See how to set current time in COMMUNICATION BASE instruction manual.

2.4 Connecting Sensor and Cable



To avoid damage to the unit, do not input a voltage and current exceeding the rated maximum to the input terminals.

3634-20: ± 40 mA, 3635-24: ± 600 mV

3635-25: ± 6 V, 3635-26: ± 60 V

Using the 3634/3635

In order to prevent electric shock and short-circuit accidents, shut off the power to the line to be measured before connecting the connection cable.

Use only the specified connection cables (9632, 9633, 9634) to connect the product input terminals to the circuit to be tested.

Connecting Temperature Sensor (3631-20, 3633-20)

3631-20 HUMIDITY LOGGER records temperature and humidity in 2 channels when connected to 9630 HUMIDITY SENSOR.

When connected to 9631 TEMPERATURE SENSOR series, humidity measurement is not available.

Connect 9631 TEMPERATURE SENSOR series to 3633-20 TEMPERATURE LOGGER. When sensor is not connected, internal temperature sensor carries out measurement.

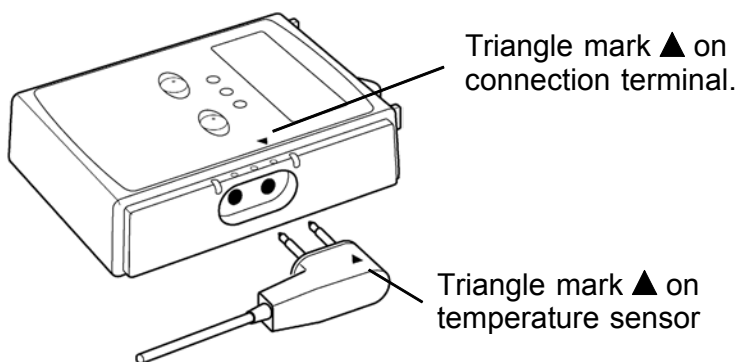

EX: 3631-20 and 9630

When connecting temperature sensor, securely insert sensor cable to unit as designated by triangle mark ▲ on connection terminal. Do not connect sensor cable in reverse. Improper connection results in failure to display accurate value.

Connecting Connection Cable (3634-20, 3635 series)

Connect 9632, 9633 or 9634 CONNECTION CABLE.

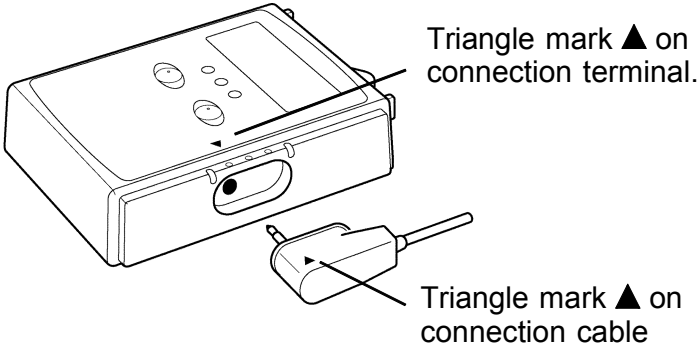

When connecting connection cable, securely insert connection cable to unit as designated by triangle mark ▲ on connection terminal. Improper connection results in failure to display accurate value.

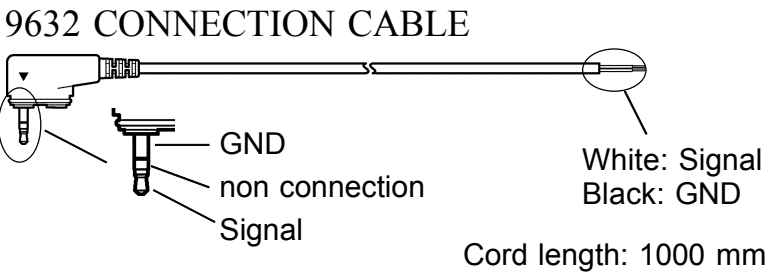

9633 CONNECTION CABLE

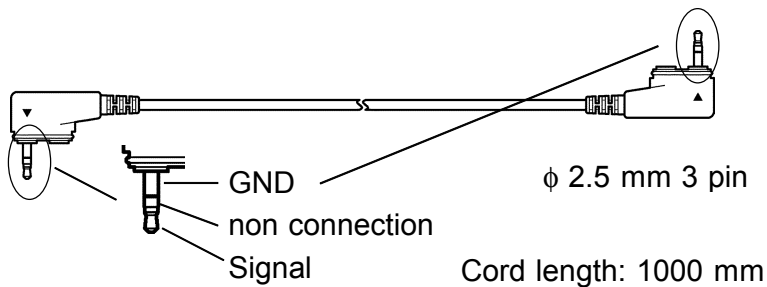

The 9633 connection cable is not compatible with 2-pin miniature jacks.

9634 CONNECTION CABLE

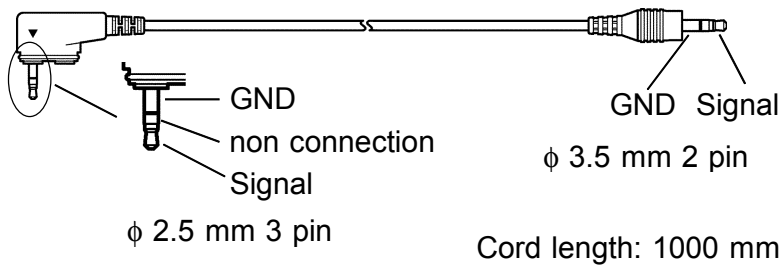

Sensors and compatible connection cables

3631-20	9630, 9631-01 to 9631-05
3632-20	none
3633-20	9631-01 to 9631-05
3634-20	9632, 9633, 9634
3635 series	9632, 9633, 9634

Chapter 3 Settings

3.1 Setting Items

Logger stand-alone manual settings and settings in combination with COMMUNICATION BASE with measurement conditions stored in memory loaded from personal computer

Setting	Logger	Logger + COMMUNICATION BASE
1. Start recording	Yes	Yes
2. Stop recording	Yes	---
3. Interval setting	Yes	Yes
4. Current time setting	---	Yes
5. Start control	---	Yes
6. Recording format setting	---	Yes
7. Comments	---	---

Yes: settable/ ---: cannot be set

Comment setting is available when personal computer is connected to logger and COMMUNICATION BASE.

1. Start recording

Start manual recording by pressing logger REC/STOP button for 1 second or initiate by prescheduled start set using COMMUNICATION BASE.

When time scheduled start is engaged, clock icon appears in display.



EX: 3631-20

When batteries are weak, recording does not start.

During recording, weak battery interrupts recording.

2. Stop recording

Stop recording by pressing logger REC/STOP button for 1 second.

Or recording stops automatically when data is full when set to recording format: one time.

3. Interval setting

Set interval with logger alone or using COMMUNICATION BASE.

(2/5/10/15/20/30 s, 1/2/5/10/15/20/30/60 min)

4. Current time setting

To set current time, see COMMUNICATION BASE instruction manual.

5. Start control

Set specific recording date and time using COMMUNICATION BASE to engage time scheduled start. When time scheduled start is engaged, clock icon appears in display.

6. Recording format setting

Set recording format using COMMUNICATION BASE.

Choose either one time or endless recording format. Default setting is one time.

One time: Ends recording when data reaches 16000 (8000 in 3631-20).

Endless : Overwrites previously recorded data when data exceeds 16000 (8000 in 3631-20).

7. Comments

Set comments entered by personal computer to logger using COMMUNICATION BASE.

When sorting collected recording data, comments are helpful.

Comment setting is available when personal computer is connected to both logger and COMMUNICATION BASE.

3.2 Manual Setting

(1) Interval setting

Press INTERVAL button to switch measurement value display to interval setting display. (**INTVL** appears.)



Press SELECT button to designate interval. Press INTERVAL button to complete setting.

(2) Starting and ending recording

Press REC/STOP button for 1 second to clear last recorded data and start recording. (**REC** appears.)

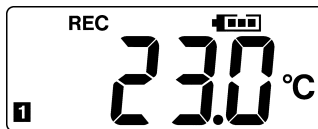

EX: 3631-20

Press REC/STOP button for 1 second to stop recording.

When memory is full, recording automatically stops when recording format: one time is selected.

When batteries are weak, recording does not start. During recording, weak batteries interrupt recording.

When the auto save function becomes on while recording, the measured value stops being displayed.

For details refer to "2.2 Power Save Function"

3.3 Setting by COMMUNICATION BASE

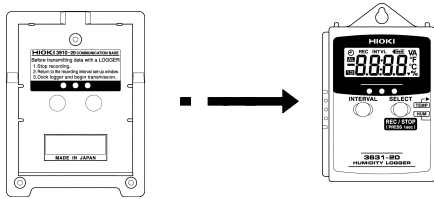

- (1) Press logger INTERVAL button lightly to display LCD.
- (2) When logger LCD shows **REC** mark or clock icon, press REC/STOP button for more than 1 second to stop recording.
During recording or waiting time before recording start time, data transfer cannot be established with COMMUNICATION BASE.
- (3) Press logger INTERVAL button to display interval setting display.
(**INTVL** appears.)
- (4) Connect COMMUNICATION BASE with logger.
- (5) Press COMMUNICATION BASE SEND button for more than 1 second to send data settings to logger.

**Previously recorded logger data is erased when recording is resumed.
Be sure to load data to be saved to COMMUNICATION BASE or to personal computer before recording.**

3.4 Connecting COMMUNICATION BASE with Logger

Align and insert Logger prongs to COMMUNICATION BASE slots and fasten Logger securely.

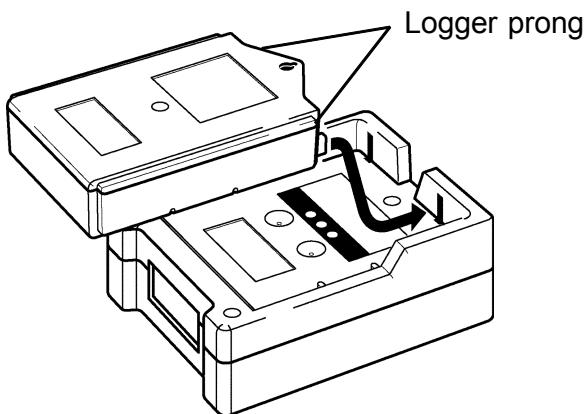

Improper connection between logger and COMMUNICATION BASE results communications failure appears.

Error reset

When error occurs in COMMUNICATION BASE, Press SEND button or RECEIVE button on COMMUNICATION BASE to reset. Logger may freeze in communications mode. Connect logger to COMMUNICATION BASE again and press COMMUNICATION BASE LOAD button. Although communications failure occurs in COMMUNICATION BASE again Logger returns to normal. Correct COMMUNICATION BASE error and reestablish communication with logger.

Chapter 4

Specifications

Logger Series General Specifications

LCD display	Measurement value (3631-20: temperature/humidity display alternates) Recording status (recording/interim) Interval (setting time) Battery status (remaining battery power indicator: 4 phases)
Recording capacity	16,000 data x 1 channel 8,000 data x 2 channels (3631-20 only)
Recording start options	Manual start, Prescheduled start
Recording options	One time, Endless
Recording stop options	Manual stop, Memory full
Interval	2/5/10/15/20/30 s 1/2/5/10/15/20/30/60 min
Data backup	Available (Data not erased by weak batteries or battery replacement)
Interface	Infrared optical data transfer
Warranty and accuracy guaranteed	1 year
Rated power	LR03 alkaline battery 1.5 V x 2

Maximum rated power 0.1 VA

Battery life About two years
(about one year in 3631-20)
With continuous recording at 20 (68°F)
temperature, power save function: on,
interval at 1 minute

Dimensions Approx. 57W x 74H x 19.5D mm
(2.24"W x 2.91"H x 0.77"D)
(excluding projections)

Mass Approx. 70 g (2.5 oz) (including batteries)

Location for use Indoors, altitude up to 2000 m (6562-ft.)

Operate temperature and humidity range -20 to 70 (-4 to 158°F),
80 %RH or less (no condensation)

Storage temperature and humidity range -20 to 70 (-4 to 158°F),
80 %RH or less (no condensation)

Standards Applying Safety EN61010-1
Measurement category I (anticipated
transient overvoltage 330 V), Pollution
Degree 2
EMC EN61326

3631-20 HUMIDITY LOGGER

Input Temperature 1 ch + Humidity 1 ch (with 9630)
When external temperature sensor is in use, internal temperature and humidity measurements are invalid.

Measurement range Temperature:
-20.0 to 70.0 (-4 to 158°F) (Internal sensor)
-40.0 to 180.0 (-40 to 356°F)
(External sensor)
0.0 to 50.0 (32 to 122°F)
(9630 HUMIDITY SENSOR)
Humidity:
(at 0 to 50 / 32 to 122°F) 20.0 to 95.0 %RH
(9630 HUMIDITY SENSOR)

Accuracy Temperature:
-40.0 to -0.1 ± 1.0 (-40 to 32°F $\pm 1.8^\circ\text{F}$)
0.0 to 35.0 ± 0.5 (32 to 95°F $\pm 0.9^\circ\text{F}$)
35.1 to 70.0 ± 1.0 (95 to 158°F $\pm 1.8^\circ\text{F}$)
70.1 to 120.0 ± 2.0 (158 to 248°F $\pm 3.6^\circ\text{F}$)
120.1 to 180.0 ± 5.0 (248 to 356°F $\pm 9^\circ\text{F}$)
Humidity:

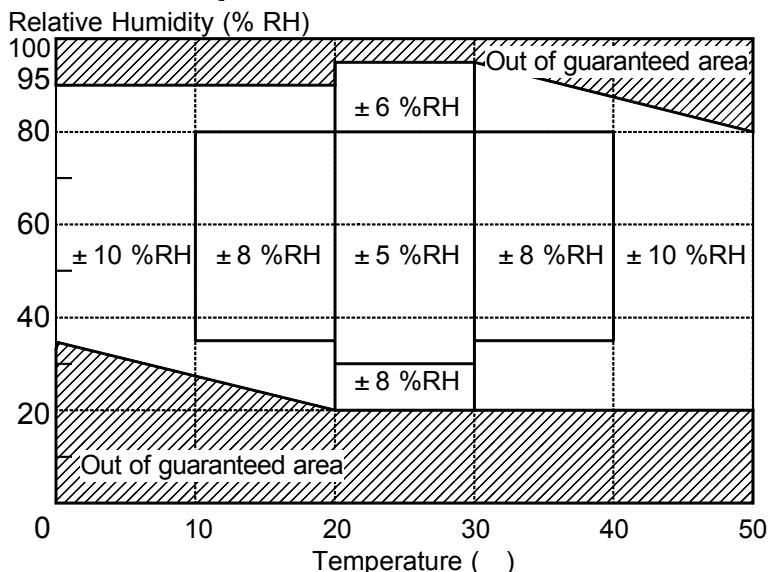

Internal temperature sensor registration	Approx. 25 min
Temperature sensor	Thermistor
Water Resilience	IP54 (water resistant)
Influence of the radiation field	± 10 at 3 V/m
Accessories	9630 HUMIDITY SENSOR Instruction Manual, LR03 alkaline battery x 2
Options	COMMUNICATION BASE 9631-01,-02,-03,-04,-05,-11,-14,-21,-24 TEMPERATURE SENSOR

Water resilience

IP 54: Not affected in showering test.

IP 67: Not affected submerged in 1 m of water, for 30 minutes.

3632-20 TEMPERATURE LOGGER

Input	Temperature 1 ch		
Measurement range	-20.0 to 70.0	(-4 to 158°F)	
Accuracy	-20.0 to -0.1	± 1.0	(-4 to 32°F ± 1.8°F)
	0.0 to 35.0	± 0.5	(32 to 95°F ± 0.9°F)
	35.1 to 70.0	± 1.0	(95 to 158°F ± 1.8°F)
Temperature sensor	Thermistor		
Internal temperature sensor registration	Approx. 25 min		
Water Resilience	IP67 (water proof)		
Influence of the radiation field	± 10	at 3 V/m	
Accessories	Instruction Manual LR03 alkaline battery x 2		
Option	COMMUNICATION BASE		

3633-20 TEMPERATURE LOGGER

Input	Temperature 1 ch When external temperature sensor is in use, internal temperature is invalid.
Measurement range	-20.0 to 70.0 (-4 to 158°F) (Internal sensor) -40.0 to 180.0 (-40 to 356°F) (External sensor)
Accuracy	-40.0 to -0.1 ± 1.0 (-40 to 32°F ± 1.8°F) 0.0 to 35.0 ± 0.5 (32 to 95°F ± 0.9°F) 35.1 to 70.0 ± 1.0 (95 to 158°F ± 1.8°F) 70.1 to 120.0 ± 2.0 (158 to 248°F ± 3.6°F) 120.1 to 180.0 ± 5.0 (248 to 356°F ± 9°F)
Temperature sensor	Thermistor
Internal temperature sensor registration	Approx. 25 min
Water Resilience	IP54 (water resistant)
Influence of the radiation field	± 10 at 3 V/m
Accessories	Instruction Manual LR03 alkaline battery x 2
Options	COMMUNICATION BASE 9631-01,-02,-03,-04,-05,-11,-14,-21,-24 TEMPERATURE SENSOR

3634-20 INSTRUMENTATION LOGGER

Sensor details	General purpose instrumentation sensor (4-20mA output, no power supply to sensor)
Input	Current 1 ch
Measurement range	0.00 to 20.00 mA, Resolution: 0.01 mA
Maximum rated input current	± 40 mA
Accuracy (23 ± 5)	± 0.8 % rdg. ± 5 dgt.
Temperature coefficient	0.08 %/
Internal resistance	Approx. 7 Ω
Influence of the radiation field	$\pm 5\%$ rdg. at 3 V/m
Accessories	9632 CONNECTION CABLE Instruction Manual LR03 alkaline battery x 2
Options	COMMUNICATION BASE 9632 CONNECTION CABLE 9633 CONNECTION CABLE 9634 CONNECTION CABLE

3635 VOLTAGE LOGGER

Input	Voltage 1 ch
Measurement range	3635-24: ± 500.0 mV (0.1 mV) 3635-25: ± 5.000 V (1 mV) 3635-26: ± 50.00 V (10 mV) Resolution: ()
Maximum rated input voltage	3635-24: ± 600 mV 3635-25: ± 6 V 3635-26: ± 60 V
Input impedance (Approx.)	3635-24: 1.5 M Ω 3635-25: 5.4 M Ω 3635-26: 5.1 M Ω
Accuracy (23 ± 5)	± 0.8 % rdg. ± 5 dgt.
Temperature coefficient	0.08 %/
Influence of the radiation field	$\pm 5\%$ rdg. at 3 V/m
Accessories	9632 CONNECTION CABLE Instruction Manual LR03 alkaline battery x 2
Options	COMMUNICATION BASE 9632 CONNECTION CABLE 9633 CONNECTION CABLE 9634 CONNECTION CABLE

Temperature Sensor Specifications

9630-X1 HUMIDITY SENSOR (cable integrated type)

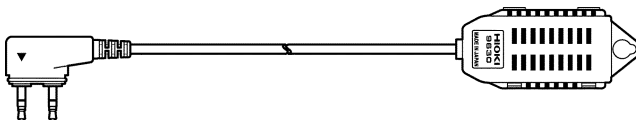

Temperature range	0 to 50 (32 to 122°F)
Humidity range	10.0 to 95.0 %RH (accuracy assured: 20.0 to 95.0 %RH)
Response time	Temperature: Approx. 100 s Humidity: Approx. 10 min
Temperature sensor	Thermistor
Humidity sensor	Macromolecular membrane (resistance method)
Cord length	9630 : 1 m (3.28-feet) 9630-01 : 5 m (16.25-feet) 9630-02 : 10 m (328-feet)
Dimensions	Sensor: 60W x 25H x 12D mm (2.36"W x 0.98"H x 0.47"D)

9631-X1 TEMPERATURE SENSOR (molded type)

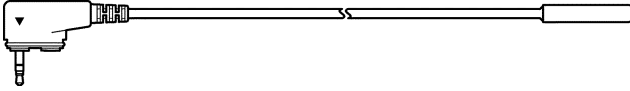

Temperature range	-40 to 180 (-40 to 356°F)
--------------------------	---------------------------

Response time	Approx. 100 s
----------------------	---------------

Moisture proof	JIS C 0920
-----------------------	------------

Temperature sensor	Thermistor
---------------------------	------------

Cord length	9631-01: 1 m (3.28-feet) 9631-11: 5 m (16.25-feet) 9631-21: 10 m (3281-feet)
--------------------	--

Dimensions	Sensor: ϕ 5 x 28 mm
-------------------	--------------------------

9631-02 TEMPERATURE SENSOR (Needle type)

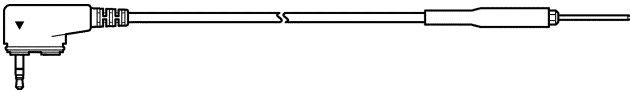

Temperature range	-40 to 120 (-40 to 248°F) (up to 180 /356°F. at the metal tip)
--------------------------	---

Response time	Approx. 20 s
----------------------	--------------

Temperature sensor	Thermistor
---------------------------	------------

Dimensions	Sensor: 25 mm, ϕ 1.3 mm Cord length: 1000 mm (3.28-feet)
-------------------	--

9631-03 TEMPERATURE SENSOR (cease type)

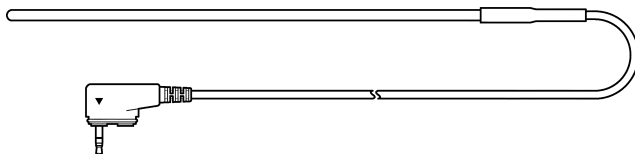

Temperature range	-40 to 120 (-40 to 248°F) (up to 180 /356°F. at the metal tip)
--------------------------	---

Response time	Approx. 90 s
----------------------	--------------

Temperature sensor	Thermistor
---------------------------	------------

Dimensions	Sensor: 180 mm, ϕ 4 mm Cord length: 1000 mm (3.28-feet)
-------------------	---

9631-X4 TEMPERATURE SENSOR (Rag connector terminal type)

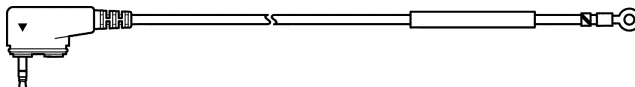

Temperature range	-30 to 180 (-22 to 356°F)
--------------------------	---------------------------

Response time	Approx. 45 s
----------------------	--------------

Temperature sensor	Thermistor
---------------------------	------------

Cord length	9631-04: 1 m (3.28-feet) 9631-14: 5 m (16.25-feet) 9631-24: 10 m (32.81-feet)
--------------------	---

Dimensions	Metal tip: 16.5 mm, Major diameter: ϕ 7 mm Minor diameter: ϕ 3.2 mm
-------------------	--

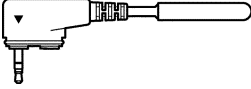
9631-05 TEMPERATURE SENSOR (molded type)

Temperature range	-40 to 180 (-40 to 356°F)
--------------------------	---------------------------

Response time	Approx. 100 s
----------------------	---------------

Temperature sensor	Thermistor
---------------------------	------------

Moisture proof	JIS C 0920
-----------------------	------------

Dimensions	Sensor: ϕ 5 x 28 mm Cord length: 30 mm (1.18inch)
-------------------	---

Response time (Reference value)

Time to display 90% value change in temperature and humidity.

Chapter 5

Maintenance and Service

Cleaning

To clean the product, wipe it gently with a soft cloth moistened with water or mild detergent. Never use solvents such as benzene, alcohol, acetone, ether, ketones, thinners or gasoline, as they can deform and discolor the case.

Service

If the product seems to be malfunctioning, confirm that the batteries are not discharged, and that the sensor are not open circuited before contacting your dealer or Hioki representative.

Pack the product carefully so that it will not be damaged during shipment, and include a detailed written description of the problem. Hioki cannot be responsible for damage that occurs during shipment.

HIOKI

DECLARATION OF CONFORMITY

Manufacturer's Name: HIOKI E.E. CORPORATION

Manufacturer's Address: 81 Koizumi, Ueda, Nagano 386-1192, Japan

Model Number and Product Name:

3631-20 HUMIDITY LOGGER
3632-20, 3633-20 TEMPERATURE LOGGER
3634-20 INSTRUMENTATION LOGGER
3635-24, 3635-25, 3635-26 VOLTAGE LOGGER

Options: 9630, 9630-01, 9630-02 HUMIDITY SENSOR
9631-01, 9631-02, 9631-03, 9631-04, 9631-05,
9631-11, 9631-14, 9631-21, 9631-24
TEMPERATURE SENSOR
9632, 9633, 9634 CONNECTION CABLE
9637, 9638 RS-232C CABLE

The above mentioned products conform to the following product specifications:

Safety: EN61010-1:2001

EMC: EN61326:1997+A1:1998+A2:2001+A3:2003
ClassB equipment
Portable test and measurement equipment.

Supplementary Information:

The products herewith comply with the requirements of the EMC Directive 89/336/EEC, but is not applicable to the Low Voltage Directive 73/23/EEC.

HIOKI E.E. CORPORATION

15 September 2006

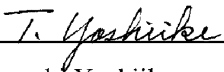

Tatsuyoshi Yoshiike
President

3631A999-04

HIOKI HIOKI 3631-20, 3632-20, 3633-20,

3634-20, 3635-24, 25, 26

Logger Series

Instruction Manual

Publication date: November 2006 Revised edition 10

Edited and published by HIOKI E.E. CORPORATION

Technical Support Section

All inquiries to International Sales and Marketing Department

81 Koizumi, Ueda, Nagano, 386-1192, Japan

TEL: +81-268-28-0562 / FAX: +81-268-28-0568

E-mail: os-com@hioki.co.jp

URL <http://www.hioki.co.jp/>

Printed in Japan 3631A981-10

- All reasonable care has been taken in the production of this manual, but if you find any points which are unclear or in error, please contact your supplier or the International Sales and Marketing Department at HIOKI headquarters.
 - In the interests of product development, the contents of this manual are subject to revision without prior notice.
 - Unauthorized reproduction or copying of this manual is prohibited.
-
-

HIOKI

HIOKI E. E. CORPORATION

HEAD OFFICE

81 Koizumi, Ueda, Nagano 386-1192, Japan
TEL +81-268-28-0562 / FAX +81-268-28-0568
E-mail: os-com@hioki.co.jp / URL <http://www.hioki.co.jp/>

HIOKI USA CORPORATION

6 Corporate Drive, Cranbury, NJ 08512, USA
TEL +1-609-409-9109 / FAX +1-609-409-9108

3631A981-10 06-11H



Printed on recycled paper

T  **USA**
Equipment
.NETTM
1-877-742-TEST (8378)