

3662-20

3663-20

LASER LIGHT SOURCE

Contents

Introduction	1
Inspection	1
Safety Notes	2
Usage Notes	4
Chapter 1 Overview	7
1.1 Product Overview	7
1.2 Features	7
1.3 Parts Names and Functions	8
Chapter 2 Measurement Procedures	11
2.1 Connecting Connectors	11
2.1.1 Connecting FC-Type Connector	12
2.1.2 Connecting SC-Type Connector	13
2.2 Turning ON/OFF Power	14
2.3 Output Modulation	15
Chapter 3 Specifications	17
3.1 Optical Output Specifications	17
3.2 General Specifications	18

Chapter 4 Maintenance and Service 19

4.1	Battery Replacement	19
4.2	Attaching/Detaching Connector Adapter ..	21
4.3	Attaching the Strap	23
4.4	Cleaning	24
4.4.1	Cleaning the Product	24
4.4.2	Cleaning Optical Output Terminal	24
4.4.3	Cleaning Cable Connector	26
4.5	Service	27

Chapter 5 Appendix 29

5.1	Options	29
-----	---------------	----

Introduction

Thank you for purchasing the HIOKI “3662-20, 3663-20 LASER LIGHT SOURCE”. To obtain maximum performance from the product, please read this manual first, and keep it handy for future reference.

Inspection

When you receive the product, inspect it carefully to ensure that no damage occurred during shipping. In particular, check the accessories, panel switches, and connectors. If damage is evident, or if it fails to operate according to the specifications, contact your dealer or Hioki representative.

Accessories

Carrying case.....	1
LR6 alkaline battery	2
Strap	1
Instruction manual	1

Before using the product

Before using the product the first time, verify that it operates normally to ensure that the no damage occurred during storage or shipping. If you find any damage, contact your dealer or Hioki representative.

Safety Notes





This product is designed to conform to IEC 61010 Safety Standards, and has been thoroughly tested for safety prior to shipment. However, mishandling during use could result in injury or death, as well as damage to the product. Be certain that you understand the instructions and precautions in the manual before use. We disclaim any responsibility for accidents or injuries not resulting directly from product defects.

This manual contains information and warnings essential for safe operation of the product and for maintaining it in safe operating condition. Before using the product, be sure to carefully read the following safety notes.

Safety Symbols



In the manual, the  symbol indicates particularly important information that the user should read before using the product.

The  symbol printed on the product indicates that the user should refer to a corresponding topic in the manual (marked with the ) before using the relevant function.

Laser Safety Information

CLASS 1 LASER PRODUCT

The 3662-20 and 3663-20 LASER LIGHT SOURCES are both Class 1 laser products conforming to IEC60825-1:2001.

FDA (CDRH)

Complies with 21 CFR 1040.10 and 1040.11 except for deviations pursuant to Laser Notice No.50, dated July 26, 2001.

The following symbols in this manual indicate the relative importance of cautions and warnings.



DANGER Indicates that incorrect operation presents an extreme hazard that could result in serious injury or death to the user.



WARNING Indicates that incorrect operation presents a significant hazard that could result in serious injury or death to the user.



CAUTION Indicates that incorrect operation presents a possibility of injury to the user or damage to the product.

NOTE

Advisory items related to performance or correct operation of the product.

Other Symbols



Indicates the prohibited action

v

Indicates the reference

Usage Notes



Follow these precautions to ensure safe operation and to obtain the full benefits of the various functions.

CAUTION

A laser beam is output from the laser output connector during operation. The laser beam is invisible. To prevent eye damage, do not look directly into the connector or look at it through a magnifying glass while the power is on.

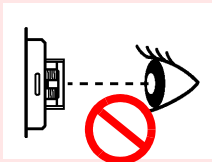

CAUTION

Direct
sunlight

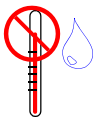

High temperature
High humidity



Dust

- Do not store or use the product where it could be exposed to direct sunlight, high temperature or humidity, or condensation. Under such conditions, the product may be damaged and insulation may deteriorate so that it no longer meets specifications.
- To avoid damage to the product, do not allow the product to get wet, and do not use it when your hands are wet.
- Do not use the product where it may be exposed to corrosive or combustible gases. The product may be damaged.
- To avoid damage to the product, protect it from vibration or shock during transport and handling, and be especially careful to avoid dropping.
- The mating portions of the laser output connector ferrule and of the connector adapter are high-precision machined parts. Make sure that these portions are free of dust or other foreign matter when connecting them. In particular, the optical output connector ferrule requires meticulous care. If there is dust in the interface or a scratch on the optical output connector ferrule, the 3662-20/3663-20 may not satisfy performance specifications.

NOTE

- After use, always turn OFF the power.
- Be sure to replace the cap to protect the device from dust when the 3662-20/3663-20 is not in use.
- The Battery replacement indicator appears when battery voltage becomes low. Replace the batteries as soon as possible.
- Use the specified battery (LR6 alkaline battery) only. Other batteries (manganese batteries, for example) run out more quickly than alkaline batteries.

Handling Optical Fiber Cable

CAUTION

Follow the precautions below to prevent damage to the optical fiber cables.

- Do not insert at an angle.

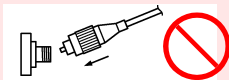

- Do not bend the cable at the neck of the connector.

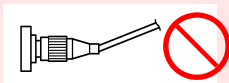

- Do not bend or twist.

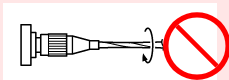

- Do not pull forcefully.

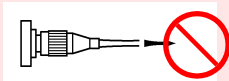

- Do not allow cable to kink.

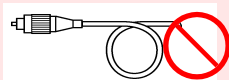

- Do not touch the end face (ferrule).

Overview

Chapter 1

1.1 Product Overview

The 3662-20/3663-20 LASER LIGHT SOURCE is a Class 1 laser source used to measure the optical loss of optical fiber cables. The laser source is designed to be used with an optical power meter. The laser source is available in two output wavelengths: 1,550 nm (3662-20) and 1,310 nm (3663-20).

1.2 Features

Output Modulation (CHOP)

This function modulates a laser output (CHOP mode, duty ratio of 50%). The modulation frequency may be selected from among the following options: continuous wave (CW), 270 Hz, 1 kHz, and 2 kHz.

1.3 Parts Names and Functions

Front

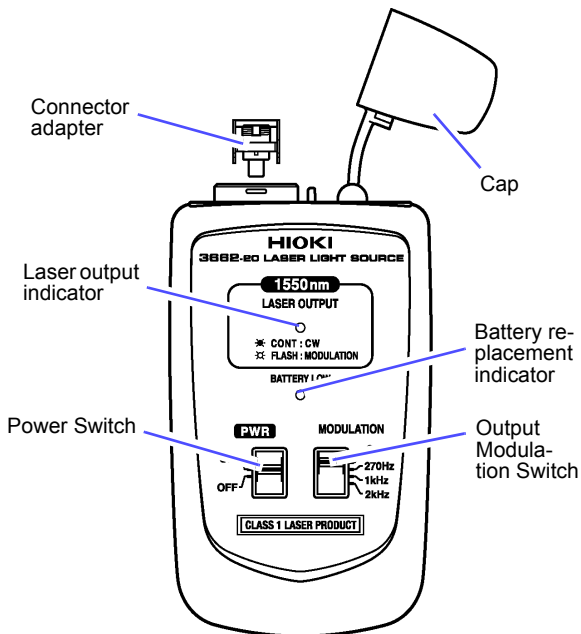

(The figure shows the 3662-20.)

NOTE

The names of the parts and the functions are the same for the 3663-20.

Connector adapter	This is attached to the laser output connector ferrule. Use the FC type or SC type depending on the connector type of the cable to be connected (optional).
Laser output indicator	When a laser beam is output, this indicator lights steadily when CW is selected with the output modulation switch and blinks when a modulated beam (270 Hz, 1 kHz, or 2 kHz) is selected.
Battery replacement indicator	Blinks when the battery is low
Power Switch	Turns power ON/OFF to the 3662-20/3663-20
Output Modulation Switch	Selects CW, 270 Hz, 1 kHz, or 2 kHz
Cap	Protects the laser output connector and the connector adapter from dust and damage. Be sure to replace when the 3662-20/3663-20 is not in use.

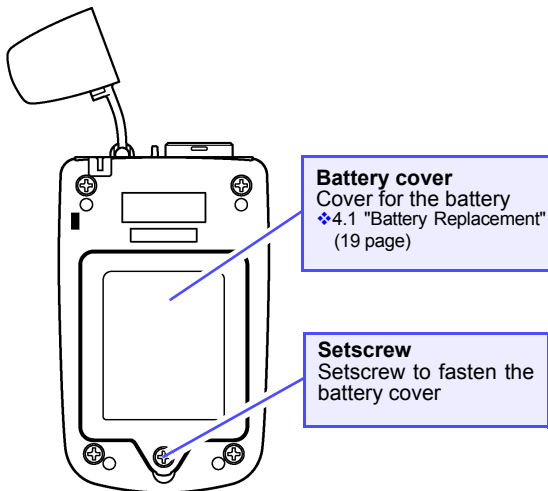
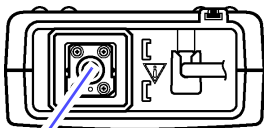
Rear**Upper**

Laser output connector ferrule
Connector ferrule for laser beam
output

Measurement Procedures

Chapter 2

2.1 Connecting Connectors



CAUTION

- A laser beam is output from the laser output connector ferrule during operation. The laser beam is invisible. To prevent eye damage, do not look directly into the connector or look at it through a magnifying glass while the power is on.

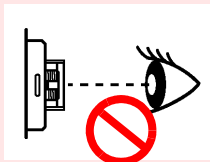

- Make sure that the mating portions are free of dust or other foreign matter when connecting an optical fiber cable to the 3662-20/3663-20. In particular, the end face (ferrule) requires meticulous care. If there is dust in the interface or a scratch on the end face, the measurement may not be accurate.

NOTE

Always clean the optical connector end face (ferrule) of the optical fiber cable before connecting.

2.1.1 Connecting FC-Type Connector

1. Insert the end face (ferrule) of the optical fiber cable into the connector adapter on the 3662-20/3663-20.
Make sure that the protrusion of the cable connector fits into the hole of the connector adapter.
2. Rotate the knurled nut (connecting nut) to tighten.

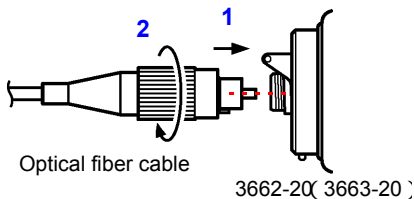

2.1.2 Connecting SC-Type Connector

Insert the end face (ferrule) of the optical fiber cable into the connector adapter on the 3662-20/3663-20.

Make sure that the protrusion of the cable connector fits into the hole of the connector adapter.

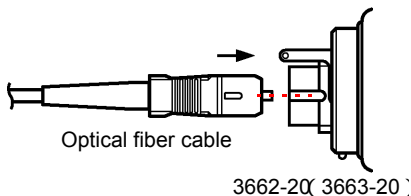

NOTE The 9735, 9736, and 9737 (optional) are optical fiber cables with an ordinary optical connector. (They are not equipped with a master connector.)

9735/9736/9737 OPTICAL FIBER CABLE Specifications

Cable	1.3 μm -band single-mode optical fiber cable
Connection loss	0.5 dB or less
Return loss	45.0 dB or more
Minimum bending radius	30 mm (Do not allow to remain bent for a long time.)

2.2 Turning ON/OFF Power

Power ON

Turn on the power switch.

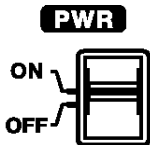

The laser output indicator will light up or start blinking and the laser output connector will output a laser beam.

NOTE

If the battery replacement indicator is blinking when power is turned on, the battery is running low. Replace with a new battery.

❖4.1 "Battery Replacement" (19 page)

Power OFF

Turn off the power switch.

2.3 Output Modulation

The laser output may be selected between a continuous wave (CW) and a 270 Hz, 1 kHz, or 2 kHz modulated wave (CHOP). The laser output indicator stays on when it is a continuous wave. The indicator blinks when it is a modulated.

Continuous wave	Continuous wave (CW) The laser output indicator stays on.
270Hz/ 1kHz/2kHz	Duty ratio of 50% Modulated beam (CHOP) at the displayed frequency The laser output indicator blinks.

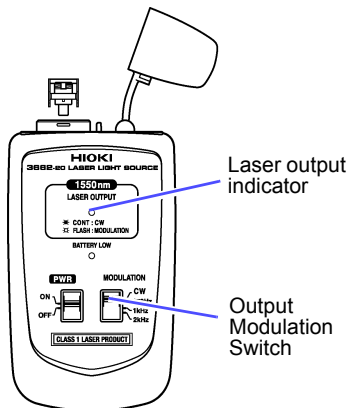

(The figure shows the 3662-20.)

NOTE The names of the parts and the functions are the same for the 3663-20.

Specifications

Chapter 3

3.1 Optical Output Specifications

Luminous element	Laser diode
Output connector	FC, SC (Using the optional connector adapter)
Applicable fiber	Single-mode fiber
Output mode	Continuous wave (CW) 270 Hz/ 1 kHz/ 2 kHz modulated (CHOP)
Output wavelength*	3662-20: 1550 ± 20 nm 3663-20: 1310 ± 20 nm (Ambient temperature: $23 \pm 5^\circ\text{C}$ ($73 \pm 41^\circ\text{F}$))
Spectrum width*	5 nm or less (Ambient temperature: $23 \pm 5^\circ\text{C}$ ($73 \pm 41^\circ\text{F}$), RMS (σ : -20 dB))
Output level*	-6 ± 2 dBm (Ambient temperature: $23 \pm 5^\circ\text{C}$ ($73 \pm 41^\circ\text{F}$))
Output-level stability*	Within ± 0.1 dB (Constant when the ambient temperature is within $23 \pm 5^\circ\text{C}$ ($73 \pm 41^\circ\text{F}$). 5 minutes)
Output-level stability*	Within 1.0 dBp-p (Ambient temperature: 0 to 40°C (32 to 104°F), 8 hours)
Operating temperature and humidity for guaranteed accuracy Period of guaranteed accuracy	$23 \pm 5^\circ\text{C}$ ($73 \pm 41^\circ\text{F}$), 80%RH or less 1 year

*Common conditions:

Single-mode fiber, FC master connector, PC polishing, and 2 meter-cable output end

3.2 General Specifications

Rated power supply	DC1.5 V X 2 LR6 alkaline battery 1.5 V X 2
Maximum rated power	0.6 VA
Operating time	3662-20: Approx. 20 hours 3663-20: Approx. 36 hours (Ambient temperature of 23°C (73°F) with a continuous beam)
Additional Functions	Battery check function (The battery replacement indicator blinks when the battery voltage is low.)
Size	Approx. 76W X 159H X 35D mm (2.99"W X 6.26"H X 1.38"D) (excluding projections)
Weight	Approx. 180 g (6.3 oz.) (excluding batteries)
Operating temperature and humidity	0 to 40°C (32 to 104°F), 80%RH or less (no condensation)
Storage temperature and humidity	-10 to 50°C (14 to 122°F), 80%RH or less (no condensation)
Operating Environment	Indoors, altitude up to 2000 m (6562 feet)
Applicable Standards	Safety EN61010-1:2001 Pollution Degree 2 EMC EN61326:1997+A1:1998+A2:2001+A3:2003 Laser IEC 60825-1:2001 Class 1 laser Complies with 21 CFR 1040.10 and 1040.11 except for deviations pursuant to Laser Notice No.50, dated July 26,2001.
Accessories	Carrying case 1 LR6 alkaline battery 2 Strap 1 Instruction manual 1
Options	9730 CARRYING CASE 9733 FC CONNECTOR ADAPTER 9734 SC CONNECTOR ADAPTER 9735 FC-FC OPTICAL FIBER CABLE 9736 SC-SC OPTICAL FIBER CABLE 9737 SC-FC OPTICAL FIBER CABLE 9738 OPTICAL CONNECTOR CLEANER 9739 SPARE CLEANER

Maintenance and Service

Chapter 4

CAUTION

Never modify the 3662-20/3663-20. Also, disassembly or repairs must be performed by qualified service engineers only. Observing these precautions will prevent fire, electrical shock, injury, or exposure to optical radiation.

4.1 Battery Replacement

WARNING

- Do not mix old and new batteries, or different types of batteries. Also, be careful to observe battery polarity during installation. Otherwise, poor performance or damage from battery leakage could result.
- After replacing the batteries, replace the cover and screws before using the product.
- To avoid the possibility of explosion, do not short circuit, disassemble or incinerate batteries.
- Handle and dispose of batteries in accordance with local regulations.

CAUTION

- To avoid corrosion from battery leakage, remove the batteries from the product if it is to be stored for a long time.
- If a optical fiber cable is bent or twisted, this may result in damage to the cable. Be sure to disconnect the optical fiber cable before replacing the battery.

NOTE

- The battery replacement indicator appears when battery voltage becomes low. Replace the batteries as soon as possible.
- Use the specified battery (LR6 alkaline battery) only. Other batteries, (manganese batteries, for example) run out more quickly than alkaline batteries.

If the battery replacement indicator is blinking when power is turned on, the battery is running low. Replace with a new battery.

1. Turn off power and disconnect the optical fiber cable from the 3662-20/3663-20.
2. Remove the setscrew and open the battery cover.
3. Replace both batteries.
4. Replace the battery cover and tighten the set-screw.

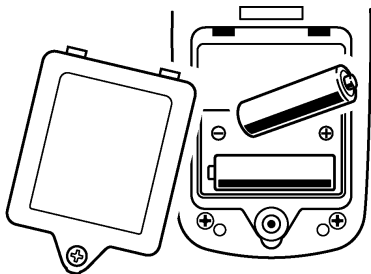

4.2 Attaching/Detaching Connector Adapter



CAUTION

- The mating portions of the laser output connector ferrule and of the connector adapter are high-precision machined parts. Make sure that these portions are free of dust or other foreign matter when connecting them. In particular, the optical output connector ferrule requires meticulous care. If there is dust in the interface or a scratch on the optical output connector ferrule, the 3662-20/3663-20 may not satisfy performance specifications.
- Make sure that power of the 3662-20/3663-20 is off when replacing the connector adapter. While power is on, do not look into the optical output connector. The laser beam may damage the eye. The laser beam is not visible.

Attachment Procedure

1. Make sure that power to the 3662-20/3663-20 is off.
2. Insert the connector adapter into the end face (ferrule) of the laser output connector. Make sure to push in the connector adapter deep enough so that the lock lever will be on the rear of the 3662-20/3663-20.
3. Push in the connector adapter fully and turn the lock lever to the rear. (Make sure that the lock is engaged.)

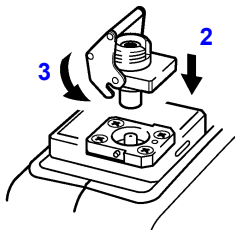

9733 FC CONNECTOR
ADAPTER

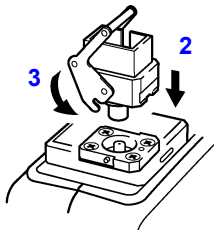

9734 SC CONNECTOR
ADAPTER

Detaching Procedure

1. Push the lock lever to the front of the 3662-20/3663-20 to unlock.
2. Gently draw out the connector adapter.

NOTE

Be sure to replace the cap of the 3662-20/3663-20 and the adapter's dust cap for protection against damage and dust when the 3662-20/3663-20 is not in use.

4.3 Attaching the Strap

Use the strap to carry the instrument, or to hang it up at the installation location.



Attach both ends of the strap securely to the instrument. If insecurely attached, the instrument may fall and be damaged when carrying.

Attaching the strap

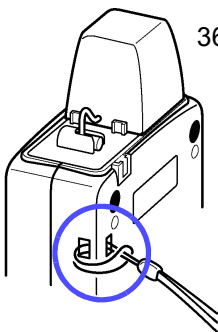

3662-20(3663-20)

Pass the strap through the strap hole of the 3662-20/3663-20 as shown in the figure.

4.4 Cleaning



4.4.1 Cleaning the Product

To clean the product, wipe it gently with a soft cloth moistened with water or mild detergent. Never use solvents such as benzene, alcohol, acetone, ether, ketones, thinners or gasoline, as they can deform and discolor the case.

4.4.2 Cleaning Optical Output Terminal

CAUTION

- The mating portions of the laser output connector ferrule and of the connector adapter are high-precision machined parts. Make sure that these portions are free of dust or other foreign matter when connecting them. In particular, the optical output connector ferrule requires meticulous care. If there is dust in the interface or a scratch on the optical output connector ferrule, the 3662-20/3663-20 may not satisfy performance specifications.
- When cleaning the optical output connector, make sure that power to the laser source is off. While power is on, do not look directly into the connector or look at it through a magnifying glass. The laser beam may damage the eye. The laser beam is not visible.

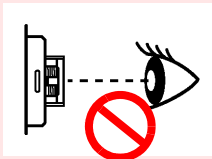

NOTE

Always clean the optical connector end face (ferrule) of the optical fiber cable before connecting.

1. Detach the connector adapter.
2. Gently wipe the laser output connector (ferrule, end face) and the surrounding area using a new cotton swab, a soft lint-proof cloth, or an optical connector cleaner (stick). Blow any fibers left on the end face (ferrule) with a blower brush designed for optical lenses. If necessary, clean with a new cotton swab moistened with isopropyl alcohol and wipe with a soft lint-proof cloth. Blow any fibers left on the end face (ferrule) with a blower brush designed for optical lenses.

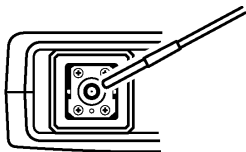

4.4.3 Cleaning Cable Connector

Use the 9738 OPTICAL CONNECTOR CLEANER to clean the connector of the optical fiber cable.

CAUTION

When cleaning the end of the optical connector, do not apply too much force with the cleaning cloth. This may result in damage to the connector and the 3662-20/3663-20 may consequently fail to satisfy performance specifications.

1. Squeeze the lever of the 9738 OPTICAL CONNECTOR CLEANER and the shutter will open, revealing the cleaning cloth.
2. While squeezing the lever, gently press the end of the optical connector against the cleaning surfaces (cleaners held in the slot shown) at a right angle. Slide the connector once in the direction of the arrow marked on the cleaners.
3. Slide the connector once per cleaning surface. There are two cleaning surfaces; thus slide the connector a total of two times. Release the lever and the shutter will shut.

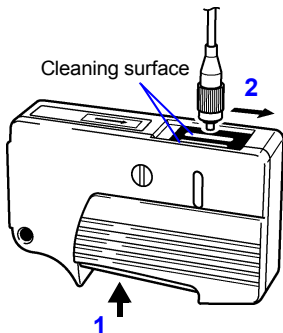

NOTE

Always clean the optical connector end face (ferrule) of the optical fiber cable before connecting.

4.5 Service

- If the product seems to be malfunctioning, confirm that the batteries are not discharged, and that the optical fiber cables are not open circuited before contacting your dealer or Hioki representative.
- When sending the product for repair, remove the batteries and pack carefully to prevent damage in transit. Include cushioning material so the instrument cannot move within the package. Be sure to include details of the problem. Hioki cannot be responsible for damage that occurs during shipment.

Appendix

Chapter 5

5.1 Options

9730 CARRYING CASE

The carrying case houses the 3661-20 OPTICAL POWER METER, 3662-20/3663-20 LASER LIGHT SOURCE, connector adapters, reference cable, and 9738 OPTICAL CONNECTOR CLEANER.

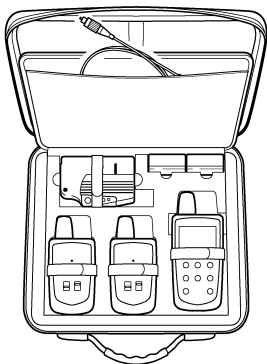

9733 FC CONNECTOR ADAPTER

FC connector adapter for the 3662-20/3663-20 LASER LIGHT SOURCE (with dust-cap attached)

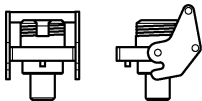

9734 SC CONNECTOR ADAPTER

SC connector adapter for the 3662-20/3663-20 LASER LIGHT SOURCE (with dust-cap attached).

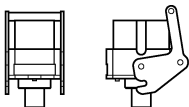
**9735 FC-FC OPTICAL FIBER CABLE**

FC-to-FC reference cable (Length: 2 m)

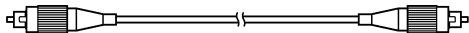
**9736 SC-SC OPTICAL FIBER CABLE**

SC-to-SC reference cable (Length: 2 m)

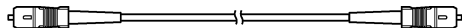

9737 SC-FC OPTICAL FIBER CABLE

SC-to-FC reference cable (Length: 2 m)

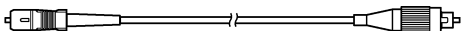

Hioki's optional optical fiber cables (9735, 9736 and 9737) are optical fiber cables with an ordinary optical connector. (They are not equipped with a master optical connector.)

9735/9736/9737 OPTICAL FIBER CABLE Specifications

Cable	1.3 μm -band single-mode optical fiber cable
Connection loss	0.5 dB or less
Return loss	45.0 dB or more
Minimum bending radius	30 mm (Do not allow to remain bent for a long time.)

9738 OPTICAL CONNECTOR CLEANER

Cleaner for optical fiber cable connector

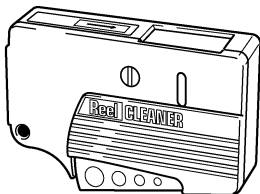
**9739 SPARE CLEANER**

Refill for the 9738 OPTICAL CONNECTOR CLEANER (6-rolls)



HIOKI

DECLARATION OF CONFORMITY

Manufacturer's Name: HIOKI E.E. CORPORATION
Manufacturer's Address: 81 Koizumi, Ueda, Nagano 386-1192, Japan
Product Name: LASER LIGHT SOURCE
Model Number: 3662-20, 3663-20
Options: 9733 FC CONNECTOR ADAPTER
9734 SC CONNECTOR ADAPTER
9735 FC-FC OPTICAL FIBER CABLE
9736 SC-SC OPTICAL FIBER CABLE
9737 SC-FC OPTICAL FIBER CABLE

The above mentioned products conform to the following product specifications:

Safety: EN61010-1:2001
EMC: EN61326:1997+A1:1998+A2:2001+A3:2003
ClassB equipment
Portable test and measurement equipment
Laser: IEC60825-1:1993+A1:1997+A2:2001
Complies with 21 CFR 1040.10 and 1040.11
except for deviations pursuant to Laser Notice
No.50, dated July 26, 2001.

Supplementary Information:

The product herewith complies with the requirements the EMC Directive 89/336/EEC, but is not applicable to the Low Voltage Directive 73/23/EEC.

HIOKI E.E. CORPORATION

15 September 2006

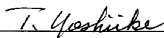

Tatsuyoshi Yoshiike
President

3662A999-02

HIOKI 3662-20,3663-20 LASER LIGHT SOURCE
Instruction Manual

Publication date: September 2006 Revised edition 2
Edited and published by HIOKI E.E. CORPORATION
Technical Support Section

All inquiries to International Sales and Marketing Department

81 Koizumi, Ueda, Nagano, 386-1192, Japan

TEL: +81-268-28-0562 / FAX: +81-268-28-0568

E-mail: os-com@hioki.co.jp

URL <http://www.hioki.co.jp/>

Printed in Japan 3662A981-02

-
-
- All reasonable care has been taken in the production of this manual, but if you find any points which are unclear or in error, please contact your supplier or the International Sales and Marketing Department at HIOKI headquarters.
 - In the interests of product development, the contents of this manual are subject to revision without prior notice.
 - Unauthorized reproduction or copying of this manual is prohibited.
-
-

HIOKI

HIOKI E. E. CORPORATION

HEAD OFFICE

81 Koizumi, Ueda, Nagano 386-1192, Japan
TEL +81-268-28-0562 / FAX +81-268-28-0568
E-mail: os-com@hioki.co.jp
URL <http://www.hioki.co.jp/>

HIOKI USA CORPORATION

6 Corporate Drive, Cranbury, NJ 08512, USA
TEL +1-609-409-9109 / FAX +1-609-409-9108

3662A981-02 06-09H



Printed on recycled paper

T  **USA**
Equipment
.NETTM
1-877-742-TEST (8378)