

INSULATION / VOLTAGE WITHSTAND TEST INSTRUMENT SERIES

Safety Standards
Measuring Instruments



New



3153



3159 CE



3158 CE



3154 CE

This electrical safety test instrument series is designed for insulation resistance and voltage withstand testing of electrical devices and components according to various safety standards. A multitude of automation and labor-saving features are provided to ensure effective testing for a wide variety of requirements and test conditions. Select the most appropriate model for your applications.



ISO14001
JQA-E-90091



3153 AUTOMATIC INSULATION / WITHSTANDING HITESTER

3159 INSULATION / WITHSTANDING HITESTER

3158 AC WITHSTANDING VOLTAGE HITESTER

3154 DIGITAL MΩ HITESTER

Model 3153

Automatic Insulation Voltage Withstand Testing

Voltage Control from a PC

Full Remote Control

All test parameters can be controlled by RS-232C or GP-IB, including test voltage, cut-off current, resistance threshold and timer durations. Start-stop control can be provided with the **9613** single hand remote control or **9614** two-hand remote control.

Standards-Based Testing

Comparator/Timer

Includes built-in pass-fail comparator and timer functions for easy compliance testing to various safety standards such as those for Electrical Appliance Safety Regulations.

Settable Ramp Up/Down Test Voltage Timing

Ramp Timer Functions

Raising and lowering of test voltage can be set for voltage withstand testing.

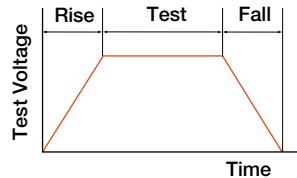

Test Status Read/Write

Program Function

Test conditions can be stored and recalled to support complete automation by sequencer. Up to 32 files can be stored with up to 50 steps per file.

Up to 32 files

Analog Voltmeter

The test voltage can be verified not only on the digital display but also on the analog meter.

Danger Lamp

The warning light flashes during testing and whenever high voltage is present at the terminals.

External Switch

Start/stop may be controlled with the **9613** or the **9614**. (The **9613** and **9614** are options.)

Fluorescent Display Tube

The display uses a bright, easy-to-read fluorescent tube.

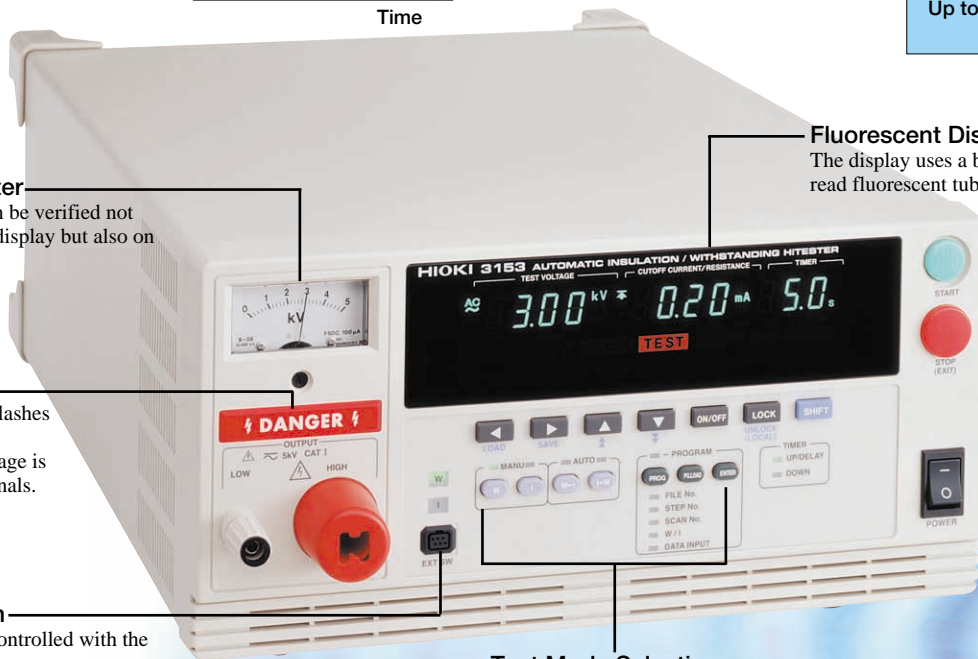

Test Mode Selection

Three test modes are selectable:

1. Manual test modes: ACW, DCW, I
2. Automatic test modes: W → I, I → W
3. Programmed test modes: testing by preprogrammed functions.

● Automation Support

Automation features include programmable testing modes, EXT I/O, RS-232C, GP-IB, connection scanning and various data management functions.

● Save 10 Sets of Test Conditions

Store up to 10 sets of test conditions for voltage withstand and insulation resistance modes, so you can quickly switch among the test conditions. (Save/Load)

● Interlock Protect Function

To ensure safety during automatic testing, test output can be interrupted and testing inhibited by input signals from automatic sensing devices.

● Auto Discharge Feature

Any charge on the object under test is discharged by the test instrument, so there is no residual charge after testing. (DC voltage withstand, insulation resistance tests)

● Zero-V Switching

Test voltage on/off switching can be forced to occur only at sine wave zero-crossings. (AC voltage withstand testing)

● PWM Switching Technique

Enhanced accuracy is obtained by preventing variations in supply voltage from affecting test voltage.

Wide Range of Functions for Various Conditions

1. Pass Hold Function (0: No Hold, 1: Hold)

The pass state is held when it is activated. This is convenient for verifying the decision value.

2. Fail Hold Function (0: No Hold, 1: Hold)

The fail state is held when it is activated. This is convenient for temporarily stopping the test process.

3. Hold State (0: No Hold, 1: Hold)

This saves the state when the Stop key is pressed during a test to unconditionally end the test.

4. Momentary Out (0: Disabled, 1: Enabled)

This function outputs a voltage only when the Start key is being pressed. The Start key is effective both for EXT SW and external I/O.

5. Double Action (0: Disabled, 1: Enabled)

This function allows testing to start only if the Start key is pressed within a half second after the Stop key.

6. Fail Mode (0: Disabled, 1: Enabled)

This function allows the Hold state to be released only by the Stop key on the instrument panel.

7. "START" Interface Command (0: Disabled, 1: Enabled)

This specifies whether the "START" command is enabled.

8. Interlock Function (0: Disabled, 1: Enabled)

This specifies whether the interlock terminal for external I/O is enabled.

9. Maximum Output Voltage

Sets the upper limit of the test voltage.

10. Insulation Resistance Measurement Range

(0: Fixed Range, 1: Automatic Range)

This specifies whether the measurement range for insulation resistance testing should be fixed or automatically determined.

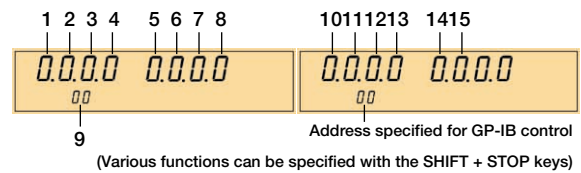

11. Insulation Resistance Test End Mode

- 0: Test for the specified time
- 1: Stop when "pass" is detected
- 2: Stop when "fail" is detected

This specifies the method of ending insulation resistance tests.

12. Ramp Time Setting

- 0: No judgment during ramp-up
- 1: Judgment during ramp-up

This specifies whether the judgment is enabled during ramp-up. Valid only during voltage withstand testing.

13. PC Interface

- 0: RS-232C (PC, 9600 bps)
- 1: RS-232C (PC, 19200 bps)
- 2: GP-IB

This specifies the type of PC interface to use.

14. Electrical Discharge Function

(0: Disabled, 1: Enabled)

This specifies whether the electrical discharge function is enabled at the end of testing.

15. Test Signal Output

- 0: ON also when TEST indicator is flashing
- 1: OFF when TEST indicator is flashing
- 2: ON only when TEST indicator is flashing (excluding ramp down time)

This specifies whether the TEST signal of the external I/O should be output when the TEST indicator is flashing.

Enhanced System Measurements

Maximum 32-Channel Multi-Point Testing

Model 3930 HIGH VOLTAGE SCANNER

Combine Model 3153 with the 3930 HIGH VOLTAGE SCANNER to perform insulation withstand testing easily. Single-end inputs test up to 8 points (between any 4 points) per instrument, and can connect up to 4 instruments together.

Model 3930 Specifications

No. of Channels	Multi-Mode: 4 High-Low channels
	Single-End Mode: 8 High-Common channels
Operating Voltage	5 kV AC, 7 kV DC
Action/Recovery Time	6 ms or less
Supply Voltage	24 V DC \pm 5% (at control signal input connector)
Size & Mass	Approx. 320(W) \times 90(H) \times 250(D) mm, 3 kg.

Simultaneous Protective Ground Continuity Testing

Safety Inspection System

Combine Model 3153 with the 3157-01 AC GROUNDING HiTESTER and a general-purpose sequencer for a simple safety test inspection system that includes protective ground continuity and insulation withstand testing.



Model 3157-01
AC GROUNDING HiTESTER

Settable current ranges:
3.0 to 31 A AC

Max. output power:
130VA

Resistance measurement range:
0 to 1.800 Ω

A Full Line-up of Models to Suit Various Needs

Model 3153

AUTOMATIC INSULATION / WITHSTANDING HITESTER



Voltage Withstand Testing

AC: 0.20 to 5.00 kV, 500 VA
DC: 0.20 to 5.00 kV, 50 VA
0.01 to 100.0 mA

Insulation Testing

DC: 50 to 1200 V
0.10 to 9999 MΩ

- Insulation and AC/DC continuous voltage withstand testing
- Safety standards compliance testing
- Stores up to 10 sets of test conditions (10 each for insulation and voltage withstand)
- Zero-V Switching (voltage withstand testing)
- Electrical Discharge function (DC voltage withstand, insulation testing)
- Automated testing support
- Interlock Protect function
- Remote controllable

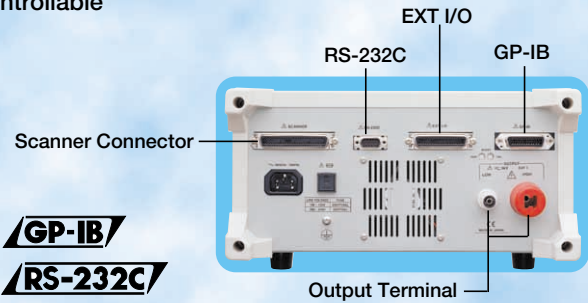

GP-IB
RS-232C

Model 3159

INSULATION / WITHSTANDING HITESTER



Voltage Withstand Testing

AC: 0 to 2.5 kV/5.0 kV, 500 VA
0.01 to 120.0 mA

Insulation Testing

DC: 500/1000 V
0.5 to 2000 MΩ

- Insulation and voltage withstand testing
- Safety standards compliance testing
- Stores up to 10 sets of test conditions (10 each for insulation and voltage withstand)
- Voltage comparator functions (voltage withstand testing)
- Zero-V Switching (voltage withstand testing)
- Electrical Discharge function (insulation testing)
- Automated testing support
- Interlock Protect function
- Remote controllable

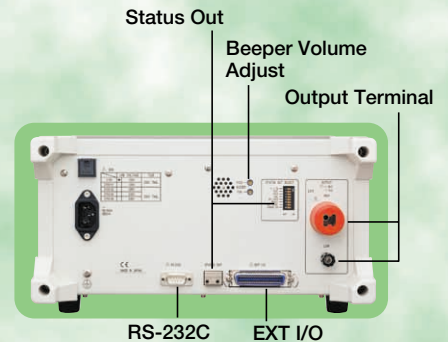

RS-232C

Model 3158

AC WITHSTANDING VOLTAGE HITESTER



Voltage Withstand Testing

AC: 0 to 2.5 kV/5.0 kV, 500 VA
0.01 to 120.0 mA

- Safety standards compliance testing
- Stores up to 20 sets of test conditions
- Voltage comparator functions
- Zero-V Switching
- Electrical Discharge function
- Automated testing support
- Interlock Protect function
- Selectable remote controls

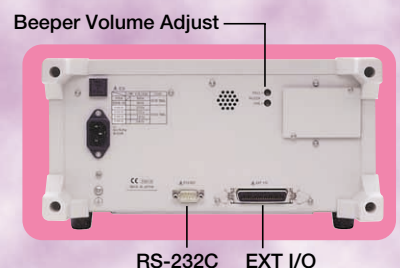

RS-232C



EXT I/O Output Signals

External control can be provided by various signals (signal lines have photocoupler isolation)

Pin	I/O	Signal	Function
1	OUT	READY	LO when in "ready state"
2	OUT	L-FAIL	LO when in "fail state" for the lower bound
3	OUT	U-FAIL	LO when in "fail state" for the upper bound
4	OUT	PASS	LO when in "pass state"
5	OUT	TEST	LO when in "test state"
6	OUT	H.V.ON	LO when voltage is present at the output terminals
7	IN	EXT-E	When LO, external I/O input signals are enabled
8	IN	START	When LO, it functions as a "Start" key
9	IN	STOP	When LO, it functions as a "Stop" key
10	IN	INT.LOCK	Interlock engaged when open
11	OUT	W-MODE	LO during voltage withstand testing
12	OUT	I-MODE	LO during insulation testing
13	OUT	W-FAIL	LO when in "fail state" for voltage withstand testing
14	OUT	I-FAIL	LO when in "fail state" for insulation testing
15-16	IN	ISO.GND	Ground inputs for external devices

Pin	I/O	Signal	Function
17-18	IN	EXT.COM	Common terminals for external devices
19	OUT	STEP-END	LO when at the end of a step
20	OUT	FILE-END	LO when at the end of a file
21	IN	FILE-E	LO when FILE 0 to 4 is in use
22	IN	FILE-0	File selection
23	IN	FILE-1	File selection
24	IN	FILE-2	File selection
25	IN	FILE-3	File selection
26	IN	FILE-4	File selection
33-34	OUT	ISO.DCV	Internal power 5V DC (60 mA)
35-36	IN	EXT.DCV	External power supply (5 to 30V DC)

Various Function Settings

1. PASS Hold function
2. FAIL Hold function
3. Hold function
4. Momentary out
5. Double actions
6. FAIL mode
7. "START" interface command
8. Interlock function
9. Maximum Output Voltage
10. Insulation Resistance measurement range
11. Insulation Resistance Test End mode
12. Ramp Timer setting
13. PC Interface
14. Electrical Discharge function
15. TEST signal output

Status Out

When the output conditions set by the DIP switches are satisfied (OR condition), output is provided at relay contacts.

1. H.V.ON	Output voltage generation
2. TEST	Testing in progress
3. PASS	Passed
4. FAIL	Failed
5. INT.LOCK	Interlocked
6. READY	Ready
7. EXT.CONT.	Under external control
8. POWER.ON	Powers the 3159 on

Pin	I/O	Signal	Function
1	OUT	READY	LO when in "ready state"
2	OUT	L-FAIL	LO when in "fail state" for the lower bound
3	OUT	U-FAIL	LO when in "fail state" for the upper bound
4	OUT	PASS	LO when in "pass state"
5	OUT	TEST	LO when in "test state"
6	OUT	H.V.ON	LO when voltage is present at the output terminals
7	IN	EXT-E	When LO, external I/O input signals are enabled
8	IN	START	When LO, it functions as a "Start" key
9	IN	STOP	When LO, it functions as a "Stop" key
10	IN	INT.LOCK	Interlock engaged when open
11	OUT	W-MODE	LO during voltage withstand testing
12	OUT	I-MODE	LO during insulation testing
13	OUT	W-FAIL	LO when in "fail state" for voltage withstand testing
14	OUT	I-FAIL	LO when in "fail state" for insulation testing
15-18	IN	ISO.COM	Ground inputs for external devices
33-36	OUT	ISO.DCV	Internal power 15V DC (100 mA)

1. PASS Hold function
2. FAIL Hold function
3. Hold function
4. Momentary out
5. Double actions
6. FAIL mode
7. "START" RS command
8. Interlock function
9. Voltage Comparator position
10. Insulation Resistance measurement range
11. Insulation Resistance Test End mode

Pin	I/O	Signal	Function
1	OUT	READY	LO when in "ready state"
2	OUT	L-FAIL	LO when in "fail state" for the lower bound
3	OUT	U-FAIL	LO when in "fail state" for the upper bound
4	OUT	PASS	LO when in "pass state"
5	OUT	TEST	LO when in "test state"
6	OUT	H.V.ON	LO when voltage is present at the output terminals
7	IN	EXT-E	When LO, external I/O input signals are enabled
8	IN	START	When LO, it functions as a "Start" key
9	IN	STOP	When LO, it functions as a "Stop" key
10	IN	INT.LOCK	Interlock engaged when open
15-18	IN	ISO.COM	Ground inputs for external devices
33-36	OUT	ISO.DCV	Internal power 15V DC (100 mA)

1. PASS Hold function
2. FAIL Hold function
3. Hold function
4. Momentary out
5. Double actions
6. FAIL mode
7. "START" RS command
8. Interlock function
9. Voltage Comparator position

Specifications

■ Voltage Withstand Testing

	Model 3153 AUTOMATIC INSULATION / WITHSTANDING HITESTER		Model 3159 INSULATION / WITHSTANDING HITESTER	Model 3158 AC WITHSTANDING VOLTAGE HITESTER
	AC	DC	AC	
Output voltage	0.20 to 5.00 kV	0.20 to 5.00 kV	Two ranges: AC 0 to 2.5 or 5.0 kV	
Voltage output method	PWM switching method (zero-switching)	PWM switching method	Zero-switching	
Transformer capacity	500 VA (rated 30 minutes)	...	500 VA (rated 30 minutes)	
Output capacity	...	50 VA (continuous)	...	
Voltage adjustment method	Digital setting (0.01 kV setting resolution)		Manual adjustment	
Output voltage accuracy	±1.5% of setting voltage ±2 dgt.		...	
Voltage change rate	±7% or less (max. 5 kV at 100 mA → unloaded: with resistive load)*2	±16% or less (max. 5 kV at 10 mA → unloaded: with resistive load)*2	...	
Voltage waveform	Sine wave (5% or less distortion, unloaded)	...	Power waveform	
Voltage frequency	50 or 60 Hz ±0.2%	...	Power synchronization	
Output ripple voltage	...	6% of output voltage or less (at 5 kV DC, 10 mA, resistive load)	...	
Output current	100 mA *1	10 mA (continuous)	...	
Voltmeter	Average rectified effective value display	Average display	Average rectified effective value display	
	Digital: 0.00 to 5.00 kV (full scale) Accuracy: ±1.5% f.s. Analog: 0 to 5 kV (full scale) Accuracy: ±5% f.s.		Digital: 0.00 to 5.00 kV (full scale) Accuracy: ±1.5% f.s. Analog: 0 to 5 kV (full scale) Accuracy: ±5% f.s.a	
Current measurement range	0.01 to 100.0 mA	0.01 to 10.0 mA	0.01 to 120.0 mA	
Indicated value range	10 or 100 mA	10 mA	2, 8, 32 or 120 mA	
Measurement resolution	0.00 to 10.00 or 0.01 mA (10-mA range) 10.1 to 100.0 or 0.1 mA (100-mA range, AC only)		0.01 mA (2- or 8-mA range), 0.1 mA (32-mA range), 1 mA (120-mA range)	
Current measurement accuracy	± (2% rdg. + 5 dgt.) common to each range *3		± (3% f.s. + 20 μA) for all ranges (at 5% power distortion or less)	

*1. Time vs. Output Voltage (at 23°C ambient)

Current Measurement Range	Max. Test Time	Standby Time
1 ≤ 60 mA	continuous	none
60 mA < 1 ≤ 100 mA	15 minutes	15 minutes

*2. Unloaded = 40 MΩ load (instrument input impedance)

*3. Plus scanner accuracy, when used.

■ Insulation Resistance Testing

	Model 3153	Model 3159	Model 3158
Test voltage	Output voltage: Positive polarity 50 to 1200V DC Voltage adjustment method: Digital setting (1V resolution) Output voltage accuracy: ±1.5% ±2 dgt. of setting level	Rated voltage: 500 or 1000V DC Unloaded voltage: 1 to 1.2 times rated voltage	...
Rated measurement current	1 mA	1 to 1.2 mA	...
Short-circuit current	200 mA or less	4 to 5 mA (500V) 2 to 3 mA (1000V)	...
Voltmeter	Average display Digital: 0 to 1200V DC (full scale) Accuracy: ±1.5% rdg. ±2 dgt. Analog: 0 to 1200V DC Accuracy: ±5% f.s. (5 kV full scale)	Average display Digital: 0 to 1200V DC (f.s.) Accuracy: ±1.5% f.s.	...
		Analog: not applicable	
Measurement range/accuracy	0.100 to 1.049 MΩ 1.05 to 10.49 MΩ*1 10.5 to 104.9 MΩ*1 105 to 9999 MΩ*1 Fundamental accuracy: ±4% rdg.*2	0.5 to 999 MΩ (500V)/±4% rdg. 1 to 999 MΩ (1000V)/±4% rdg. 1000 to 2000 MΩ /±8% rdg.	...

*1. Measurement range changes according to test voltage.

*2. Plus scanner accuracy, when used.

Decision Function

	Model 3153	Model 3159	Model 3158
Decision method	Window comparison method (digital specification)		
Decision results	UPPER-FAIL: Measured current (insulation resistance value) exceeded the specified upper bound. PASS: Measured current (insulation resistance value) was between the specified upper and lower bounds during the specified time elapsed LOWER-FAIL: Measured current (insulation resistance value) was less than the specified lower bound (Note: Model 3158 has no insulation resistance function)		
Decision processing	For each decision result, output the display portion, the beeper sound, and EXT I/O signal		
Specification ranges	Voltage withstand testing: ACV: 0.1 to 100 mA (upper bound) / 0.1 to 99 mA (lower bound) DCV: 0.1 to 10 mA (upper bound) / 0.1 to 9.9 mA (lower bound) Insulation testing: 0.10 to 9999 MΩ (same upper/lower bounds)	Voltage withstand testing: 0.1 to 120 mA (upper bound) / 0.1 to 119 mA (lower bound) Insulation testing (Model 3159 only): 0.2 to 2000 MΩ (same upper/lower bounds)	
Specification resolution	Voltage withstand testing: 0.1 mA (0.1 to 9.9 mA), 1 mA (10 to 100 mA) Insulation testing: 0.01 MΩ (0.10 to 9.99 MΩ), 0.1 MΩ (10.0 to 99.9 MΩ), 1 MΩ (100 to 9999 MΩ)	Voltage withstand testing: 0.1 mA (0.1 to 9.9 mA), 1 mA (10 to 120 mA) Insulation testing (Model 3159 only): 0.01 MΩ (0.2 to 2 MΩ), 0.1 MΩ (2.1 to 20 MΩ), 1 MΩ (21 to 200 MΩ), 10 MΩ (210 to 2000 MΩ)	

Timers

	Model 3153	Model 3159	Model 3158
Testing timer	Specification range: 0.3 to 999 s Specification resolution: 0.1 s (0.3 to 99.9 s), 1 s (100 to 999 s) Accuracy: ±0.5% of specified value	Specification range: 0.5 to 999 s Specification resolution/accuracy: 0.1 s (0.5 to 99.9 s), ±50 ms; 1 s (100 to 999 s) ±0.5 s	
	Action: (when ON is specified) after starting, the countdown from the specified time is displayed. (when OFF is specified) displays the elapsed time from starting		
Ramp timer (withstand test time)	Specification range: 0.1 to 99.9 s ramp-up and -down specified separately Specification resolution/accuracy: 0.1 s, ±0.5% of specified value	...	
Delay timer (insulation resistance test time)	Specification range: 0.1 to 99.9 s Specification resolution/accuracy: 0.1 s, ±0.5% of specified value Action: specify a delay time after testing is set to begin to inhibit decisions during that time	Non-deterministic interval: 0.5 s (Mask time until determination begins during insulation resistance testing)	...

Interfaces

	Model 3153	Model 3159	Model 3158
EXT I/O	Open-collector outputs, active low, max. 30V DC loaded voltage, all signal lines photocoupler-isolated		
EXT SW	START, STOP, SW.EN (panel terminal switch enabled), connection point inputs		
RS-232C	Start-stop synchronization, full duplex, 9600 or 19200 bps	Start-stop synchronization, full duplex, 9600 bps	
GP-IB	IEEE 488.2 (1987) compliant	...	

General Specifications

	Model 3153	Model 3159	Model 3158
Display	Fluorescent display tube (digital display), analog meter		
Monitor functions	Output voltage, detected current, measured resistance		Output voltage, detected current
Monitor period	2 times per second minimum		
Operating temperature range	0 to 40 °C, 80% RH maximum (non-condensating)		
Storage temperature range	-10 to 50 °C, 90% RH maximum (non-condensating)		
Temperature and humidity range for guaranteed accuracy	23 ± 5 °C, 80% RH maximum (non-condensating) (after 10-min. warm-up for 3153, or 5-min. warm-up for 3158 and 3159)		
Operating environment	Indoors, up to 2000m ASL		
Power supply voltage	100 to 240V AC (installed fuse depends on actual voltage, so specify supply voltage when ordering) 100 to 120V AC: installed fuse 250V T10AL 200 to 240V AC: installed fuse 250V T5AL	100V AC (3159), 120V AC (3159-01), 220V AC (3159-02), 230V AC (3159-03), 240V AC (3159-04)	120V AC (3158-01), 220V AC (3158-03), 230V AC (3158-04), 240V AC (3158-05)
Power supply frequency	50 or 60 Hz		
Max. power consumption	1000 VA	800 VA	
Withstand voltage	Power supply to chassis: 1.35 kV AC at 15 mA for 1 min.	Power supply to chassis: 1.35 kV AC at 10 mA for 1 min.	
Dimensions	Approx. 320 (W) × 155 (H) × 480 (D) mm	Approx. 320 (W) × 155 (H) × 330 (D) mm	Approx. 320 (W) × 155 (H) × 263 (D) mm
Mass	Approx. 18 kg	Approx. 18 kg (3159), 20.5 kg (3159-01), 21.5 kg (3159-02 to 3159-04)	Approx. 16 kg (3158-01), 18 kg (3158-03 to 3159-05)
Applicable standards	EMC: EN 61326-1:1997 + A1:1998 Class A, EN 61000-3-2:1995 + A1:1998+ A2:1998, EN 61000-3-3:1995 Safety: EN 61010-1:1993 + A2:1995 Contamination Level 2, Measurement Category II (anticipated overvoltage category 2500V) EN 61010-2-031:1994		
Supplied accessories	9615 H.V. TEST LEADS (high voltage side and return, one each), POWER CORD, EXTRA FUSE		
Options	9613 REMOTE CONTROL BOX (SINGLE), 9614 REMOTE CONTROL BOX (DUAL), 9637 RS-232C CABLE (9-pin Dsub to 9-pin Dsub), 9638 RS-232C CABLE (9-pin Dsub to 25-pin Dsub), 9267 SAFETY TEST DATA MANAGEMENT SOFTWARE	9616 WARNING LAMP	
	3930 HIGH VOLTAGE SCANNER 9151-02 GP-IB CONNECTOR CABLE (2m) 9151-04 GP-IB CONNECTOR CABLE (4m)		

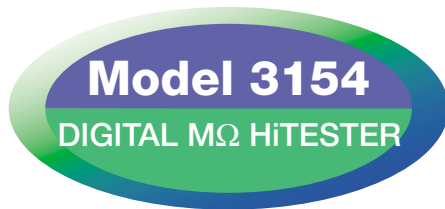

- Six test voltages from 25 to 1000V
- Stores 10 setting states
- Easy standards testing with comparator timer function
- Automatic electrical discharge feature
- Minimize instability with slow sampling
- Record changes with analog output



[Measurement Voltage/Range (Auto/Manual range switching)]

Measurement voltage	25V	50V	100V	250V	500V	1000V
Measurement range	2,000, 20.00 and 200.0 MΩ		2,000, 20.00 and 2000 MΩ		2,000, 20.00, 200.0 and 4000 MΩ	
Accuracy	±2% rdg., ±5 dgt.		0 to 20.00 MΩ		0 to 100.0 MΩ	0 to 999 MΩ
	±5% rdg.		19.0 to 200.0 MΩ	19.0 to 2000 MΩ	100.1 to 2000 MΩ	1000 to 4000 MΩ
Unloaded voltage	1 to 1.2 times the measurement voltage					
Min. meas. resistance	0.025 MΩ	0.05 MΩ	0.1 MΩ	0.25MΩ	0.5MΩ	2MΩ
Rated meas. current	1 to 1.2 mA					0.5 to 0.6 mA
Short-circuit current	1.2 mA or less					0.6 mA or less

3153 AUTOMATIC INSULATION / WITHSTANDING HiTESTER

■ Options

- 3930 HIGH VOLTAGE SCANNER
- 9613 REMOTE CONTROL BOX (SINGLE)
- 9614 REMOTE CONTROL BOX (DUAL)
- 9151-02 GP-IB CONNECTOR CABLE (2m)
- 9151-04 GP-IB CONNECTOR CABLE (4m)
- 9637 RS-232C CABLE (1.8 m) (9pin-9pin/Cross)
- 9638 RS-232C CABLE (1.8 m) (9pin-25pin/Cross)
- 9267 SAFETY TEST DATA MANAGEMENT SOFTWARE

3159 INSULATION / WITHSTANDING HiTESTER (100V AC)

- 3159-01 INSULATION / WITHSTANDING HiTESTER (120V AC)
- 3159-02 INSULATION / WITHSTANDING HiTESTER (220V AC)
- 3159-03 INSULATION / WITHSTANDING HiTESTER (230V AC)
- 3159-04 INSULATION / WITHSTANDING HiTESTER (240V AC)

■ Options

- 9613 REMOTE CONTROL BOX (SINGLE)
- 9614 REMOTE CONTROL BOX (DUAL)
- 9616 WARNING LAMP
- 9637 RS-232C CABLE (1.8 m) (9pin-9pin/Cross)
- 9638 RS-232C CABLE (1.8 m) (9pin-25pin/Cross)
- 9267 SAFETY TEST DATA MANAGEMENT SOFTWARE

- 3158-01 AC WITHSTANDING VOLTAGE HiTESTER (120V AC)
- 3158-03 AC WITHSTANDING VOLTAGE HiTESTER (220V AC)
- 3158-04 AC WITHSTANDING VOLTAGE HiTESTER (230V AC)
- 3158-05 AC WITHSTANDING VOLTAGE HiTESTER (240V AC)

■ Options

- 9613 REMOTE CONTROL BOX (SINGLE)
- 9614 REMOTE CONTROL BOX (DUAL)
- 9637 RS-232C CABLE (1.8 m) (9pin-9pin/Cross)
- 9638 RS-232C CABLE (1.8 m) (9pin-25pin/Cross)
- 9267 SAFETY TEST DATA MANAGEMENT SOFTWARE



9613
REMOTE CONTROL BOX (SINGLE)



9614
REMOTE CONTROL BOX (DUAL)



9615
H.V. TEST LEADS



9616
WARNING LAMP
(100V AC, 0.1A)

When using Model 9616 with Models 3153 or 3158, please contact HIOKI for specific details.

HIOKI

HIOKI E. E. CORPORATION

T
Equipment
.NET



205 Westwood Ave
Long Branch, NJ 07740
1-877-742-TEST (8378)
Fax: (732) 222-7088
salesteam@Equipment.NET