

INSTRUCTION MANUAL

Digital Clamp Meter

Model: GCM-302/303

Thank you for purchasing our products. Please read this instruction manual before using the meter and keep it properly for contingent use.

GW INSTEK

Made to Measure

GOOD WILL INSTRUMENT CO., LTD.

T +886-2-2268-0389 F +886-2-2268-0639

E-mail: marketing@goodwill.com.tw

www.gwinstek.com.tw

CONTENT INDEX

Precaution.....	1-3
Name of Parts and Description.....	4-5
Measuring Instruction	
• ACA measurement (set on \tilde{A}).....	6
• ACV measurement (set on $\underset{\sim}{V}$).....	7
• DCV measurement (set on $\underset{\sim}{V}$).....	7
• Resistance measurement (set on Ω).....	8
• Diode check (set on \rightarrow).....	9
• Continuity check (set on \bullet)).....	10
Auto Power Off Device	10
Battery Replacement Steps	11
Specification List.....	12-14

Please read this instruction manual before using the meter and keep it properly for contingent use.

PRECAUTION:

To avoid danger and damage happened during operation, the following symbols are used as points for attention.



:Warning: Improper use of the meter may bring hurt or even death to body. Please read the operation carefully.



:Caution: Improper use of the meter may bring hurt or even death to body. Please read the operation carefully.



:Dual insulation



:AC - (Alternating Current) voltage / current



:DC - (Direct Current) voltage



:Grounding - Earth Terminal

Warning

■ To prevent electrical shock or fire!

- Before measurement, make sure that the test leads and function switch has been set properly.
- Before switching among functions, remove the test leads off the measured object.
- Before measurement, make sure the circuit current of object won't exceed the maximum measurement range.
- Do not use this meter if any crack or damage occurred in the case or test leads.
- Do not open the case of meter or the battery lib during measurement.
- Please keep your hands behind the guard ring of test leads while measuring with test leads.
- Please keep your hands below the guard ring of the meter while measuring with sensing jaw.
- Before proceeding resistance measurement, turn off the power to the circuit under test first.
- Never use the meter in rainy or humid environment or with wet hands.
- Before proceeding current measurement, make sure to remove the test leads from the input terminals.

Warning

■ To prevent damage to the meter or electrical shock!

According to the safety standard, the maximum voltage input power is classified as follows to protect the users against transient impulse voltage in power lines.

Over-voltage Category (CAT.)	Maximum input voltage
CAT II	600V

Caution

- Do not use the meter near equipment emitting noise or under an environment with sudden temperature change; otherwise, unstable or erroneous reading will appear.
- Take the batteries out of the meter if it will be left idle for a long time.
- After measurement, switch the function knob back to OFF position. As there will be slight power consumption under auto power off mode.
- Please position the conductor in the center of jaw in order to ensure the accuracy of measurement while measuring current.
- Please make sure to keep out of high current to ensure the accuracy of measurement while measuring current.
- Do not use organic solvent to clean the meter but with a soft cloth if necessary.
- Do not expose the meter under direct sunshine or extreme temperature or in moisture places.
- When the measurement values appear irregularly or the **+ -** symbol displays, replace the batteries immediately to ensure normal operation.

(1) NAME OF PARTS

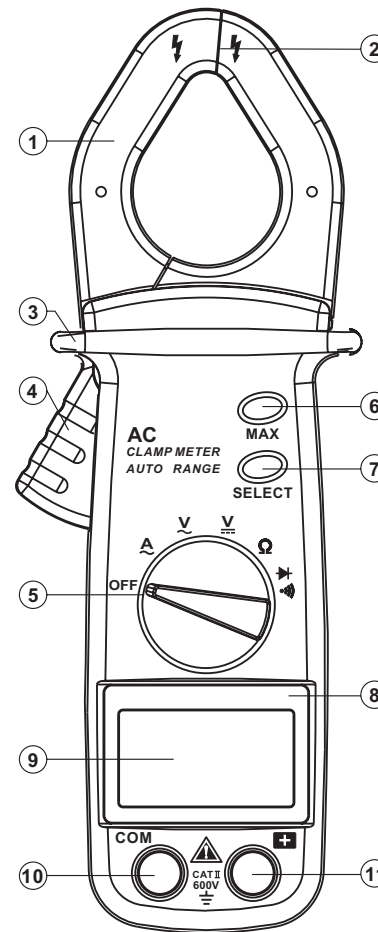

① **Jaw**

Position the conductor in the center of jaw in order to ensure the accuracy of reading while measuring current.

② **Opening of the jaw**

③ **Guard ring**

Keep your hands below the guard ring of the meter while measuring with sensing jaw.

④ **Clamp trigger**

Press down the trigger to open the jaw.

⑤ **Function switch knob**

OFF	Turn off the power
\tilde{A}	AC current measurement
\tilde{V}	AC voltage measurement
$\underline{\underline{V}}$	DC voltage measurement
Ω	Resistance measurement
\rightarrow/\rightarrow	Diode / Continuity check

⑥ **MAX key**

Press MAX key during measurement, **MAX** symbol will appear on the LCD; and the maximum value will be locked and renewed instantaneously. To cancel this function, just press MAX key again and **MAX** symbol will disappear.

Note: This function is only applicable to \tilde{A} , \tilde{V} & $\underline{\underline{V}}$

⑦ **SELECT key**

Transform between diode and continuity check.

⑧ **Name plate**

Mark product brand and model number

⑨ **LCD Display**

Show measurement symbols, units and values

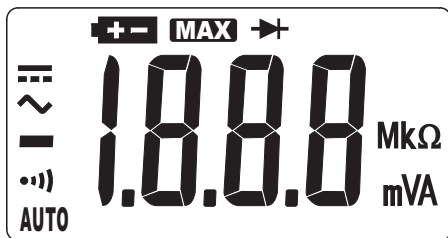

Symbols / Units	Description
≡	Lit when in DC mode measurement
~	Lit when in AC mode measurement
—	Negative polarity indicator
••))	Lit when in continuity check
AUTO	Auto-ranging indicator
+—	Low battery indicator
A	Unit for current measurement
mV, V	Unit for voltage measurement
MΩ, kΩ, Ω	Unit for resistance measurement
MAX	Maximum value lock indicator
▶	Lit when in diode measurement
1.0.0.0	Measured value display

⑩ **COM Terminal**

For connecting the negative input end (black test lead) for DCV, ACV, Ω, ▶ & ••)) measurement

⑪ **⊕ terminal**

For connecting the positive input end (red test lead) for DCV, ACV, Ω, ▶ & ••)) measurement

(2) MEASURING INSTRUCTIONS

■ AC Current Measurement (A)

Measuring range: 200A~600A (2 ranges, auto-ranging)

1. Set the function switch knob on A
2. Press down the clamp trigger to open the jaw, place one conductor in the center of the jaw (as below drawing), then read the value when it stabilizes.

Note: Please put the conductor in the center of jaw in order to avoid serious inaccuracy

3. The meter will choose the appropriate range to measure automatically.
4. When measurement finished, set the function switch knob on OFF position to turn off the meter.

Note: If the measurement is conducted in a place with dim light, you may press MAX key to lock the value measured and read it in other places with proper illumination.

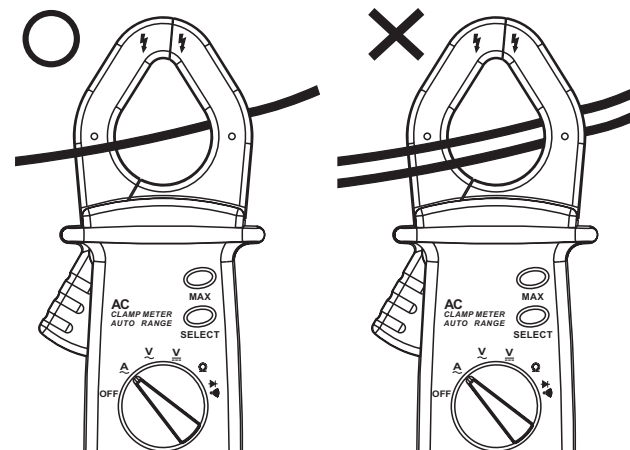

■ AC Voltage Measurement (\underline{V})

Measuring range: 2V-600V (4 ranges, auto-ranging)

1. Set the function switch knob on \underline{V}
2. Plug the black test lead into COM terminal and the red one into \oplus terminal
3. Connect the test leads to the circuit under test and then read the value when it stabilizes
4. The meter will choose the appropriate range to measure automatically
5. When measurement finished, set the function switch knob on OFF position to turn off the meter.

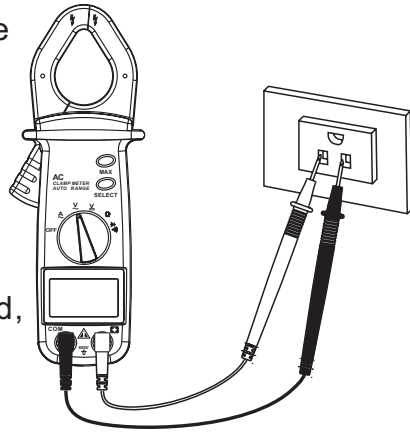

■ Resistance Measurement (Ω)

Measuring range: 200 Ω -20M Ω (6 ranges, auto-ranging)

1. Set the function switch knob on Ω
2. Plug the black test lead into COM terminal and the red one into \oplus terminal
3. Connect the test leads to the circuit under test and then read the value when it stabilizes
4. The meter will choose the appropriate range to measure automatically
5. When measurement finished, set the function switch knob on OFF position to turn off the meter.

 : Before undergoing resistance measurement, firstly switch off the power to the circuit under test and fully discharge the capacitor.

■ DC Voltage Measurement (\underline{V})

Measuring range: 200mV-600V (5 ranges, auto-ranging)

1. Set the function switch knob on \underline{V}
2. Plug the black test lead into COM terminal and the red one into \oplus terminal
3. Connect the test leads to the circuit under test and then read the value when it stabilizes
4. The meter will choose the appropriate range to measure automatically
6. When measurement finished, set the function switch knob on OFF position to turn off the meter.

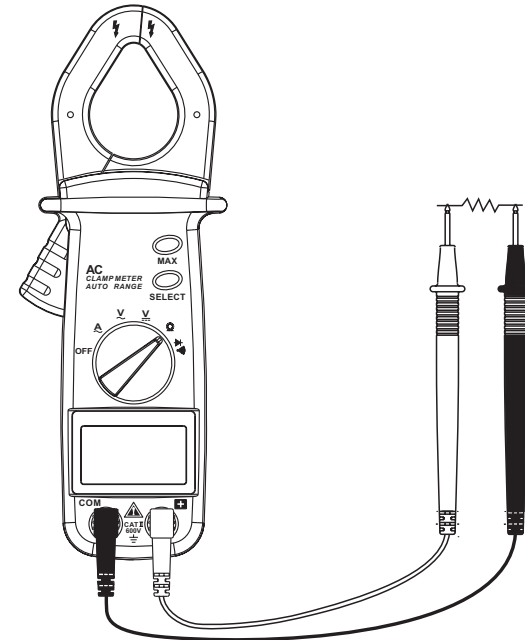
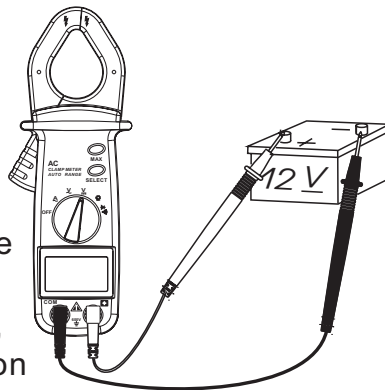

■ Diode Check (→▶)

1. Set the function switch knob on →▶/•••••)
2. →▶ Symbol will appear on the LCD
3. Connect the test leads to the diode and then read the value when it stabilizes

(A) Forward-bias Diode Test

Connect black test lead to the cathode and red one to the anode

Silicon diode value reading approximate 0.5~0.7V

Germanium diode value reading approximate 0.5~0.7V

Note that reading close to 0V represents a short-circuit and "OL" symbol indicates an open-circuit.

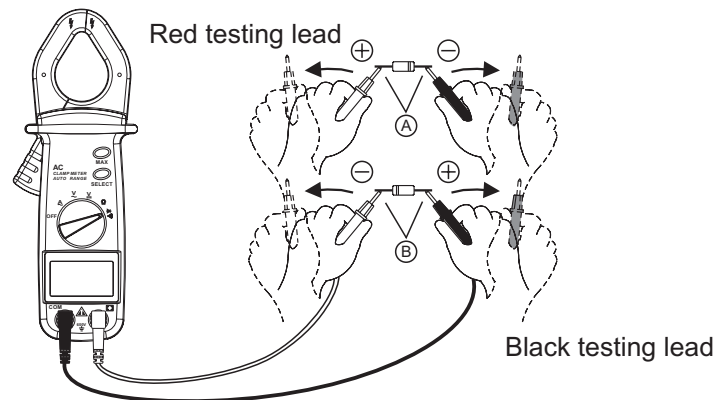

(B) Reverse-bias Diode Test

Connect black test lead to the anode and red one to the cathode. Normally, it shows OL on display, indicating that the diode under test is normal. The diode is defective if the display gives a certain voltage level.

4. When measurement finished, set the function switch knob on OFF position to turn off the meter.

■ Continuity Measurement (•••••)

1. Set the function switch knob on →▶/•••••)
2. Press SELECT key until ••••• symbol appears on LCD
3. Plug the black test lead into COM terminal and the red one into + terminal
4. Connect the test leads to the circuit under test. If circuit is continuous or less than $60\ \Omega (\pm 20\ \Omega)$, the beeper will sound
5. When measurement finished, set the function switch knob on OFF position to turn off the meter.

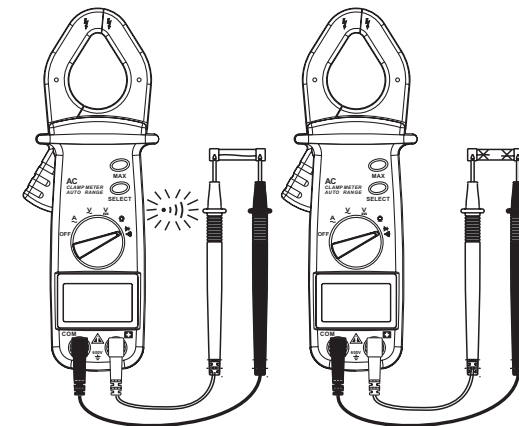

(3) AUTO POWER OFF (POWER-SAVING) DEVICE

When power on the meter and you don't touch any key or function switch knob for 15 minutes, the meter will turn the power off automatically. One minute before the meter shut down, the alarm sounds to warn the users. Once the meter turns the power off already, you can press the MAX key to regenerate the meter again.

(4) Replacing Batteries

If **+ -** symbols appears, the batteries fall below the normal operation voltage. Replace them with 2 new batteries.
(Standard UM-4 or R03 AAA batteries)

⚠ CAUTION

- Before replacing batteries, make sure to disconnect the clamp meter from the circuit under test.
- Replace two new batteries at the same time, and make sure you put the batteries at correct polarities.

(5) Battery Replacement Steps

- 1.Abort the measuring action
- 2.Turn the function switch knob back to OFF
- 3.Remove the screw on the back of casing (as drawing)
- 4.Open the battery lid
- 5.Load the new batteries
- 6.Install the battery lid into the casing and fasten it with the screw

Remove the screw
on the back of casing

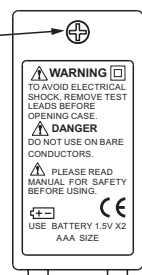

Battery lid

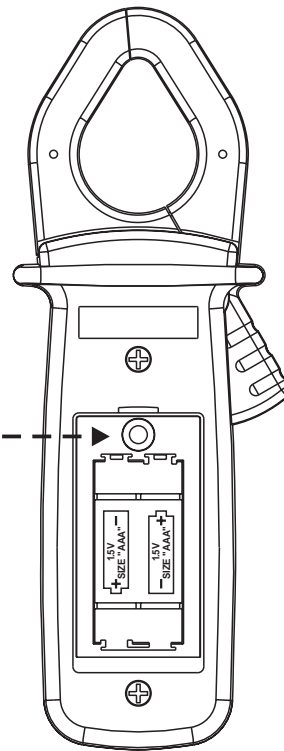

(6) Specification

1. General Specification:

- **Max Clamp Size:** \varnothing 30mm or 10x35mm
- **Measurement Functions:** \underline{A} , \underline{V} , \underline{V} , Ω , \rightarrow , \bullet
- **Additional Functions:** Max hold, auto power off
- **LCD Display:**
Unit & function indication, 1999 digits as maximum reading, negative polarity indicator, overload indicator ("OL" indicating overload of resistance, beeper, diode), **+ -** indicating low battery.
- **Range:** Auto-ranging
- **Sampling Rate:** approx. 3 times per second
- **Operation Temperature/Humidity:**
 $0^{\circ}\text{C}\sim 50^{\circ}\text{C}$ ($32^{\circ}\text{F}\sim 122^{\circ}\text{F}$) / below 80% R.H.
(no condensation)
- **Storage Temperature/Humidity:**
 $-10^{\circ}\text{C}\sim 60^{\circ}\text{C}$ ($14^{\circ}\text{F}\sim 140^{\circ}\text{F}$) / below 70% R.H.
(no condensation)
- **Power Supply:** 2 pcs of standard UM-4 or R03 AAA batteries
- **Battery Life:**
Alkaline batteries approx. 400 hours
General batteries approx. 240 hours
- **Dimensions:** 189mm(L) x 71mm(W) x 37mm(H)
- **Weight:** approx. 200g (batteries included)

- **Comply with Safety Standard:** IEC 61010-1 600V CAT II
Pollution degree 2

- **Accessories:** AAA 1.5V2 (inside the case)
Test leads.....1
Instruction manual1
Carrying case.....1

• **Optional Accessories:**

AC Line Splitter

(Direct measuring with no necessity to split the wire away by negative and positive independently. Hence, it also can amplify the small current by 10 times for easy reading)

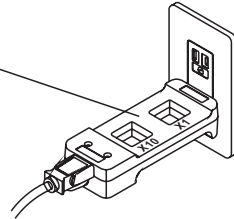

2. Electrical Specification:

Environment temperature/ humidity: $23 \pm 5^{\circ}\text{C}$ / below 80% R.H.

rdg: reading digits

dgt: decimal digits

■ **ACA measurement (set on A)**

Accuracy : $\pm(\% \text{rdg} + \text{dgt})$ 50~500Hz

Range	Resolution	AVG Accuracy GCM-302	True RMS Accuracy GCM-303	Maximum Input Current
200A	0.1A	$\pm(1.9\% \text{rdg} + 10 \text{dgt})$		600A
600A	1A	$\pm(1.9\% \text{rdg} + 5 \text{dgt})$		

■ **ACV measurement (set on V)**

40~500Hz

Range	Resolution	AVG Accuracy GCM-302	True RMS Accuracy GCM-303	Input Impedance	Maximum Input Voltage
2V	0.001V	$\pm(1.5\% \text{rdg} + 10 \text{dgt})$		Approx. 11M Ω	600V rms
20V	0.01V			Approx. 10M Ω	
200V	0.1V	$\pm(1.5\% \text{rdg} + 5 \text{dgt})$			
600V	1V				

■ **DCV measurement (set on V)**

Range	Resolution	Accuracy	Input Impedance	Maximum Input Voltage
200mV	0.1mV	$\pm(0.7\% \text{rdg} + 3 \text{dgt})$	$\geq 100 \text{M}\Omega$	600V
2V	0.001V	$\pm(1.3\% \text{rdg} + 3 \text{dgt})$	Approx. 11M Ω	
20V	0.01V		Approx. 10M Ω	
200V	0.1V	$\pm(1\% \text{rdg} + 3 \text{dgt})$		
600V	1V			

■ **Resistance measurement (set on Ω)**

Range	Resolution	Accuracy	Open-Loop Voltage	Maximum Input Voltage
200 Ω	0.1 Ω	$\pm(1.5\% \text{rdg} + 5 \text{dgt})$	Approx. 0.4V	600V
2k Ω	0.001k Ω			
20k Ω	0.01k Ω			
200k Ω	0.1k Ω			
2M Ω	0.001M Ω	$\pm(5\% \text{rdg} + 5 \text{dgt})$		
20M Ω	0.01M Ω	$\pm(10\% \text{rdg} + 5 \text{dgt})$		

■ **Diode check (set on \rightarrow)**

Range	Resolution	Accuracy	Open-Loop Voltage
2V	0.001V	$\pm(10\% \text{rdg} + 5 \text{dgt})$	Approx. 1.5V

■ **Continuity check (set on $\bullet\bullet$)**

Range	Resolution	Accuracy	Open-Loop Voltage	Maximum Input Voltage
200 Ω	0.1 Ω	The buzzer turns on for resistances lower than $60\Omega \pm 20\Omega$	Approx. 0.4V	600V

Specification and outward appearance of the product described above may be revised for modification without prior notice.



205 Westwood Ave
Long Branch, NJ 07740
1-877-742-TEST (8378)
Fax: (732) 222-7088
salesteam@Tequipment.NET