

EC Declaration of Conformity

We

GOOD WILL INSTRUMENT CO., LTD.

No. 7-1, Jhongsing Rd., Tucheng City, Taipei County 236, Taiwan.

GOOD WILL INSTRUMENT (SUZHOU) CO., LTD.

No. 69 Lushan Road, Suzhou New District Jiangsu, China.

declare that the below mentioned product

PEL-300

is herewith confirmed to comply with the requirements set out in the Council Directive on the approximation of the Law of Member States relating to Electromagnetic Compatibility (89/336/EEC,92/31/EEC,93/68/EEC)and Low Voltage Equipment Directive (73/23/EEC, 93/68/EEC).

For the evaluation regarding the Electromagnetic Compatibility and Low Voltage Equipment Directive, the following standards are applied:

EN 61326-1:Electrical equipment for measurement, control and laboratory use—EMC requirements (1997+A1:1998)					
Conducted Emission	EN 55022 class B (1994)		Electrostatic Discharge	IEC 1000-4-2	(1995)
Radiated Emission			Radiated Immunity	IEC 1000-4-3	(1995)
Current Harmonics	EN 61000-3-2	(1995)	Electrical Fast Transients	IEC 1000-4-4	(1995)
Voltage Fluctuations	EN 61000-3-3	(1995)	Surge Immunity	IEC 1000-4-5	(1995)
-----	-----	-----	Conducted Susceptibility	EN 61000-4-6	(1996)
-----	-----	-----	Power Frequency Magnetic field	EN 61000-4-8	(1993)
-----	-----	-----	Voltage Dip/Interruption	EN 61000-4-11	(1994)

Low Voltage Equipment Directive 73/23/EEC & amended by 93/68/EEC
IEC/EN 61010-1:2001

CONTENTS

1. INTRODUCTION	1
1-1 Features.....	1
2. SPECIFICATIONS	2
3. OPERATION	5
3-1 Front and rear panels.....	5
3-2 Operations	9
(1). Constant Voltage Mode	10
(2). Constant Current Mode	10
(3). Constant Resistance Mode.....	11
(4). Setting of maximum input power.....	11
(5). Setting of operational frequency	12
(6). Setting of operational duty	13
(7). Setting of dynamic mode	13
(8). Setting of LOAD ON/OFF	13
(9). Setting of STEP	14
(10).Setting of MEMORY	14
(11).Setting the duration of execution	16
(12).Setting of repeated executions	17
(13).Setting of auto execution	18
4. CALIBRATION PROCEDURES	19
4-1 Adjusting the reference voltage of C.V. MODE	19
4-2 Adjusting the reference voltage in 10 Ω ~1k Ω range of C.R. MODE	20
4-3 Calibrating the D/A in 10 Ω range of C.R. MODE.....	20
4-4 Calibrating the OFFSET of C.R. MODE	21
4-5 Calibrating the D/A of C.V. MODE	22
4-6 Calibrating the D/A, A/D in 6A range of C.C. MODE	22
4-7 Calibrating the D/A in 6A range of W SET	23

4-8	Calibrating the D/A, A/D in 0.6A range of C.C. MODE	24
4-9	Calibrating the D/A in 0.6A range of W SET	24
4-10	Calibrating the D/A, A/D in 60A range of C.C. MODE	25
4-11	Calibrating the D/A in 60A range of W SET	26
4-12	Calibrating the reference voltage in 1Ω range of C.R. MODE	26
4-13	Calibrating the D/A in 1kΩ range of C.R. MODE	27
4-14	Calibrating the D/A in 100Ω range of C.R. MODE	28
4-15	Calibrating the D/A in 1Ω range of C.R. MODE	29
4-16	Calibrating the 100Hz~1kHz range of SW MODE	30
4-17	Calibrating the D/A in 10Hz~100Hz range of SW MODE	31
4-18	Calibrating the D/A in 1Hz~10Hz range of SW MODE	32
4-19	D/A Calibrating the SENSE current offset of C.C., C.R. MODE	33
5.	APPLICATION	34
5-1	The Table of the error message	34
5-2	Test Lead	35
6.	Safety summary	36

1. INTRODUCTION

1-1 Features

- ✦ Simple operation with smart push buttons
- ✦ High resolution (20mV, 0.2mA, 0.33mΩ)
- ✦ With voltage, current and power overload prevention functions
- ✦ Easy access to maximum 100 files
- ✦ Voltage range: 3 ~ 60V
- ✦ Current range: 6mA ~ 60A
- ✦ Maximum power: 300W
- ✦ Operational modes: constant voltage (CV), constant current (CC), and constant resistance (CR)
- ✦ With self-testing and auto software calibration functions
- ✦ Meet UL CSA IEC requirement

2. SPECIFICATIONS

Functions			Modes	Ranges	
Operational Limits	Voltage Range			3 ~ 60V	
	Current Range			6mA ~ 60A	
	Power Range			1 ~ 300W	
Constant Voltage (CV) Mode	Applicable Range			3 ~ 60 V	
	Accuracy			$\pm(0.1\% + 40mV)$	
	Resolution			20mV	
	Step			20mV ~ 6V	
Constant Current (CC) Mode	Applicable Range			6mA ~ 60V	
	Accuracy		6A ~ 60A	$\pm(0.5\% + 100mA)$	
			0.6A ~ 6A	$\pm(0.1\% + 10mA)$	
			6mA ~ 0.6A	$\pm(0.1\% + 1mA)$	
	Resolution		6A ~ 60A	20mA	
			0.6A ~ 6A	2mA	
			6mA ~ 0.6A	0.2mA	
	Step		6A ~ 60A	20mA ~ 6A	
0.6A ~ 6A			2mA ~ 6A		
6mA ~ 0.6A			0.2mA ~ 6A		
Constant Current (CC) Mode	Dynamic Status	Frequency	Range	1Hz ~ 1kHz	
			Accuracy	$\pm 5\%$	
			Resolution	100Hz ~ 1kHz	5Hz
				10Hz ~ 100Hz	0.5Hz
		Cycle	1Hz ~ 10Hz	0.05Hz	
			Range	10% ~ 90%	
			Accuracy	$\pm 10\%$	
	Resolution	1%			

Functions		Modes	Ranges
Constant Resistance (CR) Mode	Applicable Range		50mΩ ~ 1kΩ
	Accuracy	100Ω ~ 1kΩ	±(5% + 1Ω)
		10Ω ~ 100Ω	±(5% + 100mΩ)
		1Ω ~ 10Ω	±(5% + 10mΩ)
		50mΩ ~ 1Ω	±(5% + 1mΩ)
	Resolution	100Ω ~ 1kΩ	330mΩ
		10Ω ~ 100Ω	33mΩ
		1Ω ~ 10Ω	3.3mΩ
		50mΩ ~ 1Ω	0.33mΩ
	Step	100Ω ~ 1kΩ	330mΩ ~ 100Ω
		10Ω ~ 100Ω	33mΩ ~ 100Ω
		1Ω ~ 10Ω	3.3mΩ ~ 10Ω
50mΩ ~ 1Ω		0.33mΩ ~ 1Ω	
Power Setting	Applicable Range		1 ~ 300W
	Accuracy		±(2% + 4W)
	Resolution		0.1W
Voltage Readback	Accuracy		±(0.1% + 60mV)
	Resolution		20mV
Current Readback	Accuracy	6A ~ 60A	±(0.5% + 100mA)
		0.6A ~ 6A	±(0.1% + 10mA)
		6mA ~ 0.6A	±(0.1% + 1mA)
	Resolution	6A ~ 60A	20mA
		0.6A ~ 6A	2mA
6mA ~ 0.6A		0.2mA	
Memory	Number of Data Saving		0 ~ 99

Functions		Modes	Ranges
Timer	Time Setting		1 sec. ~ 999 min. 59 sec.
	Resolution		1 sec.
Temperature	Dynamic Operation		0°C ~ 40°C
	Storage		-10°C ~ 70°C
Humidity	Dynamic Operation		80% (Max.)
	Storage		70% (Max.)
Power Source	AC 100V, 120V, 220V, 240V ± 10% 50/60 Hz		
Replace Fuse Type	110V/120V	T 0.5A 250V	
	220V/240V	T 0.2A 250V	
Rated Input	Watts	40W	
	VA	50VA	
Operation Environment	In door		
	Altitude up to 2,000m		
	Installation Category II		
	Pollution Degree 2		
Accessories	User's Manual x 1; Power Cord x 1		
Dimensions	255mm(D) x 145mm(H) x 346mm(W)		
Weight	9kg (approx.)		

3. OPERATION

3-1 Front and rear panels

Graph 3-1 Front Panel

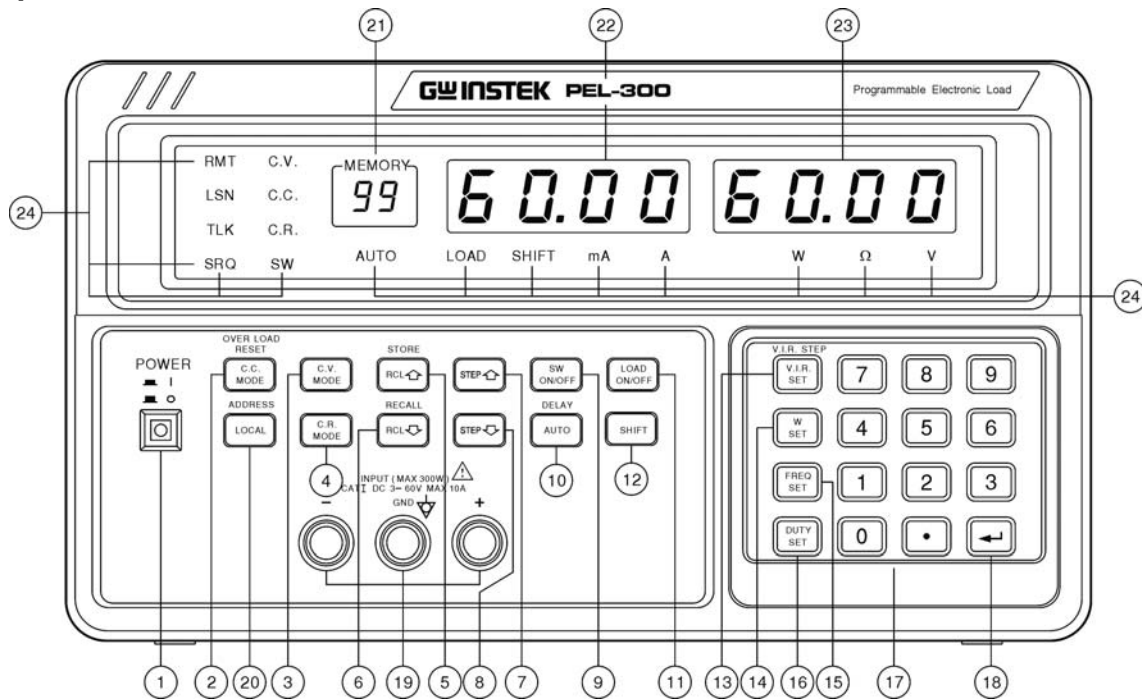

Graph 3-2 Rear Panel

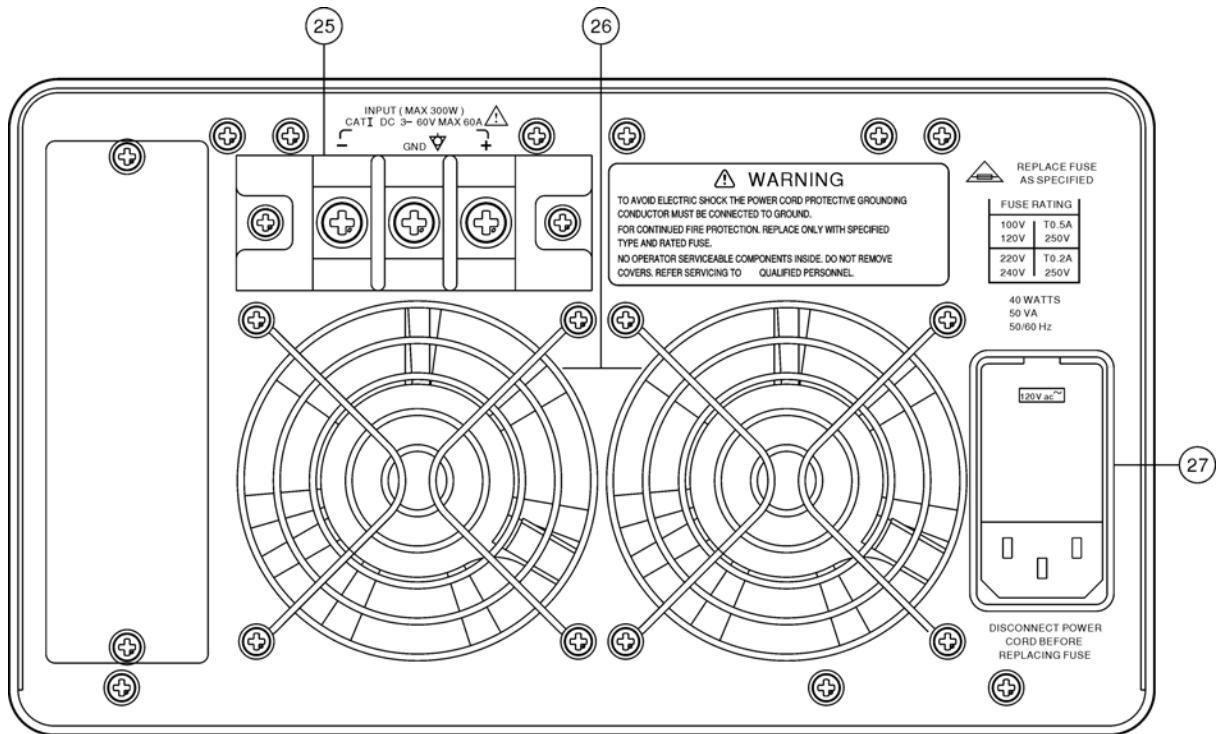

- ① POWER : “■” -- power is on; “■” -- power is off.
- ② C.C. MODE : To set operation in constant current mode.
- ③ C.V. MODE : To set operation in constant voltage mode.
- ④ C.R. MODE : To set operation in constant resistance mode.
- ⑤ RCL ▲ : To recall the previous batch of memorized data.
- ⑥ RCL ▼ : To recall the next batch of memorized data.
- ⑦ STEP ▲ : To add a STEP value to the values of pre-set voltage, current and resistance.
- ⑧ STEP ▼ : To subtract a STEP value from the values of pre-set voltage, current and resistance.
- ⑨ SW ON/OFF : To switch on/off dynamic operational mode.
- ⑩ AUTO : To execute automatically based on pre-set data (under LOAD ON status ONLY).
- ⑪ LOAD ON/OFF : Turn on/off LOAD function.
- ⑫ SHIFT : To shift and proceed secondary functions.
 - (1) SHIFT + C.C. MODE(Over Load Reset): To cancel overload protection.
 - (2) SHIFT + LOCAL(ADDR): To set location of GPIB.
 - (3) SHIFT + RCL ▲ (STO): To save current data in memory.
 - (4) SHIFT + RCL ▼(RCL): To recall data from memory, or to retrieve the number of starting batch and ending batch, and the times of execution of the memory that will be applied.
 - (5)SHIFT + AUTO (DLY): To set the time of execution.
 - (6)SHIFT + V.I.R. SET(V.I.R. STEP): To set the step value of voltage, current, and resistance.

- ⑬ V.I.R. SET : To set the values of input voltage, current, and resistance.
- ⑭ W SET : To set the maximum of input power.
- ⑮ FREQ. SET : To set the frequency in dynamic operational mode.
- ⑯ DUTY SET : To set DUTY under dynamic operational mode.
- ⑰ 0 ~ 9 : The buttons for input numbers.
- ⑱ ↵ : To complete data inputting.
- ⑲ DC INPUT : The input terminal of the electronic load (Max.10A).
- ⑳ LOCAL : Not used
- ㉑ MEMORY : To display different sets of data memorized.
- ㉒ DISPLAY A : To display current applied.
- ㉓ DISPLAY V : To display voltage applied.
- ㉔ DISPLAY : To display unit, status, and mode.
- ㉕ DC INPUT : The input terminal of the electronic load (Max. 60A).
- ㉖ Ventilator : To exhaust hot air.
- ㉗ AC SOCKET : Its circuit includes a fuse, a distributor, and a filter.

3-2 Operations

Graph 3-3

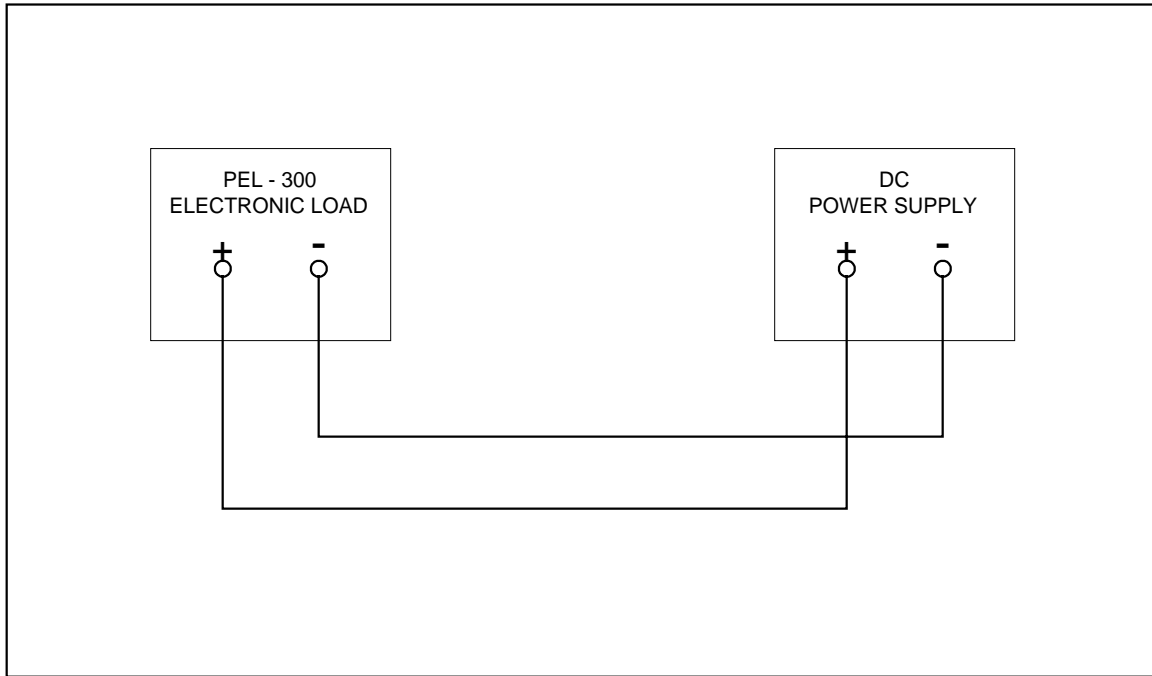

(1) Constant Voltage Mode:

- ❶ Connect the instrument according to Graph 3-3.
- ❷ Turn the power switch to “ON” position, then press C.V. MODE button (the light of C.V. MODE will be on).
- ❸ Press LOAD ON/OFF button (the light of LOAD will be on), the displays will indicate the value of external voltage and current.

Example:

To set input voltage at 20V in constant voltage mode

- | | |
|---------|--------------------------------------|
| STEP 1. | Press C.V. MODE |
| STEP 2. | Press V.I.R. SET |
| STEP 3. | Press 20 (unit is specified as “V”) |
| STEP 4. | Press ↵ |

(2). Constant Current Mode:

- ❶ Connect the instrument according to Graph 3-3.
- ❷ Turn the power switch to “ON” position, then press C.C. MODE button (the light of C.C. MODE is on).
- ❸ Press LOAD ON/OFF button (the light of LOAD is on), the displays will indicate the value of external voltage and current.

Example:

To set input current at 1.248A in constant current mode

- | | |
|---------|---|
| STEP 1. | Press C.C. MODE |
| STEP 2. | Press V.I.R. SET |
| STEP 3. | Press 1.248 (unit is specified as “A”) |
| STEP 4. | Press ↵ |

(3). Constant Resistance Mode:

- ❶ Connect the instrument according to Graph 3-3.
- ❷ Turn the power switch to “ON” position, then press C.R. MODE button (the light of C.R. MODE is on).
- ❸ Press LOAD ON/OFF button (the light of LOAD is on), the displays will indicate the value of external voltage and current.

Example:

To set input resistance at 500Ω in constant resistance mode

- | | |
|---------|---------------------------------------|
| STEP 1. | Press C.R. MODE |
| STEP 2. | Press V.I.R. SET |
| STEP 3. | Press 500 (unit is specified as “Ω”) |
| STEP 4. | Press ↵ |

(4). Setting of maximum input power:

- ❶ Select C.V. MODE, C.C. MODE or C.R. MODE.
- ❷ When the light of the selected mode is on, press W SET button. Input desired W value after the display indicating the original W value.
- ❸ Press LOAD ON/OFF button.

Example:

To set maximum input power at 300W

- | | |
|---------|---------------------------------------|
| STEP 1. | Press W SET |
| STEP 2. | Press 300 (unit is specified as “W”) |
| STEP 3. | Press ↵ |

(5). Setting of operational frequency:

- ❶ Connect the instrument according to Graph 3-3.
- ❷ Turn the power switch to “ON” position, then press C.C. MODE button (the light of C.C. MODE is on).
- ❸ Press FREQ. SET button; then input desired FREQ. value after the display indicating the original FREQ. value.

Example:

To set operational frequency as 1000Hz

- | | |
|---------|---|
| STEP 1. | Press FREQ. SET |
| STEP 2. | Press 1000 (unit is specified as “Hz”) |
| STEP 3. | Press ↵ |

(6). Setting of operational duty:

- ❶ Connect the instrument according to Graph 3-3.
- ❷ Turn the power switch to “ON” position, then press C.C. MODE button (the light of C.C. MODE is on).
- ❸ Press DUTY SET button; then input desired DUTY value after the display indicating the original DUTY value.
- ❹ Press LOAD ON/OFF button.

Example:

To set operation duty at 50%

- | | |
|---------|--------------------------------------|
| STEP 1. | Press DUTY SET |
| STEP 2. | Press 50 (unit is specified as “%”) |
| STEP 3. | Press ↵ |

(7). Setting of dynamic mode:

- ❶ Connect the instrument according to Graph 3-3.
- ❷ Turn the power switch to “ON” position, then press C.C. MODE button (the light of C.C. MODE is on).
- ❸ Press SW ON/OFF button; the light of SW is on which indicates the operation is proceeded in dynamic mode.

Note: be sure to complete the settings of FREQ. and DUTY before setting the dynamic mode.

Example:

To set operation in dynamic mode

- STEP 1. Press SW ON/OFF button (the light of SW is on)
- STEP 2. Press LOAD ON/OFF button
(the light of LOAD is on which indicates the operation is in SW mode)

(8). Setting of LOAD ON/OFF:

- ❶ Turn the power switch to “ON” position, then press C.C. MODE, C.V. MODE or C.R. MODE button.
- ❷ Press LOAD ON/OFF button; the light of LOAD is on which indicates the load has been turned on.
- ❸ Press LOAD ON/OFF button again; the light of LOAD is out which indicates the load has been turned off.

Note: Make sure the preset input power is not too low that may cause an error message.

9). Setting of STEP:

- 1 Turn the power switch to “ON” position, then press SHIFT button to enable the secondary functions.
- 2 Press V.I.R. SET button, key in digits to specify the value of STEP, then press ↵ button to complete the setting.

Examples:

- ♦ To set STEP value at 0.02A in C.C. MODE

STEP 1. Press SHIFT
STEP 2. Press V.I.R. SET
STEP 3. Press 0.02
STEP 4. Press ↵

- ♦ To set STEP value at 1V in C.V. MODE

STEP 1. Press SHIFT
STEP 2. Press V.I.R. SET
STEP 3. Press 1
STEP 4. Press ↵

- ♦ To set STEP value at 0.33Ω in C.R. MODE

STEP 1. Press SHIFT
STEP 2. Press V.I.R. SET
STEP 3. Press 0.33
STEP 4. Press ↵

(10). Setting of MEMORY:

- 1 Turn the power switch to “ON” position, then press C.C. MODE, C.V. MODE or C.R. MODE button.
- 2 Set operational voltage, current, resistance, frequency, DUTY, time, and the times of execution.
- 3 Press SHIFT key to enable the secondary functions; press RCL ▲ ; key in digits to specify a batch; then press ↵ to complete the setting and to save them in the memory.

Note: Be sure to complete the setting of the data to be saved before proceeding execution.

Examples:

- ♦ In C.V. MODE, to set voltage at 10V, W SET at 300W, STEP at 1V and to save current data in the 99th batch.

STEP 1.	C.V. MODE	STEP 9.	V.I.R. SET
STEP 2.	V.I.R. SET	STEP10.	1
STEP 3.	10	STEP11.	┘
STEP 4.	┘	STEP12.	SHIFT
STEP 5.	W SET	STEP13.	RCL ▲
STEP 6.	300	STEP14.	99
STEP 7.	┘	STEP15.	┘
STEP 8.	SHIFT		

- ♦ In C.C. MODE, to set current at 1A, power at 300W, STEP at 0.2A, FREQ. at 1000Hz, DUTY at 50%. To work in SW MODE, and save data in the 11th batch.

Note: In addition to setting the values of current, power and STEP, FREQ. SET, and DUTY SET should also be set while proceeding the setting of C.C. MODE SW function.

STEP 1.	C.C. MODE	STEP12.	FREQ. SET
STEP 2.	V.I.R. SET	STEP13.	1000
STEP 3.	1	STEP14.	┘
STEP 4.	┘	STEP15.	DUTY SET
STEP 5.	W SET	STEP16.	50
STEP 6.	300	STEP17.	┘
STEP 7.	┘	STEP18.	SW ON/OFF
STEP 8.	SHIFT	STEP19.	SHIFT
STEP 9.	V.I.R. SET	STEP20.	RCL ▲
STEP10.	0.2	STEP21.	11
STEP11.	┘	STEP22.	┘

- ♦ To save data in current batch

STEP 1. SHIFT
STEP 2. RCL ▲
STEP 3. ┘

(Assume MEMORY indicates 33, data will then be saved in the 33rd batch right after proceeding the 3 STEPs aforementioned.)

(11). Setting the duration of execution:

- ❶ Press SHIFT to enable the secondary function.
- ❷ Press AUTO key and key in digits with a decimal (number before the decimal means “minute”; the one after the decimal is specified as “second”) for the duration of execution.

Examples:

- ♦ To set the running time as 20 minutes and 38 seconds

STEP 1. SHIFT
STEP 2. AUTO
STEP 3. 20.38
STEP 4. ┘

- ♦ To set the running time as 40 seconds

STEP 1. SHIFT
STEP 2. AUTO
STEP 3. 0.40
STEP 4. ┘

(12). Setting of repeated executions:

- ❶ Press SHIFT to enable the secondary function.
- ❷ Press RCL▼ key.
- ❸ Key in three sets of digits with two decimals in between. The first set of the digits is specified as “the starting batch”, the second set is specified as “the ending batch”, and the last set is specified as “the number of executions.”
- ❹ Then press ↵ .

Example:

- ♦ To run batch 1 to batch 98 for 99 times
 - STEP 1. SHIFT
 - STEP 2. RCL ▼
 - STEP 3. 1.98.99
 - STEP 4. ↵
 - STEP 5. AUTO
 - STEP 6. LOAD ON/OFF
- ♦ To retrieve data from batch 1 till batch 18
 - STEP 1. SHIFT
 - STEP 2. RCL ▼
 - STEP 3. 1.18
 - STEP 4. ↵
- ♦ To run batch 1 to batch 98 endlessly
 - STEP 1. SHIFT
 - STEP 2. RCL ▼
 - STEP 3. 1.98
 - STEP 4. ↵
 - STEP 5. AUTO
 - STEP 6. LOAD ON/OFF
- ♦ To retrieve data from the 10th batch
 - STEP 1. SHIFT
 - STEP 2. RCL ▼
 - STEP 3. 10
 - STEP 4. ↵

(13). Setting of auto execution:

- ❶ The light of AUTO is out when auto execution is not functioning.
- ❷ Press AUTO button, the indicator will light up, and the function will be turned on.

Note: Be sure to complete the settings of item 1 to 7 and 10 to 12 before proceeding the setting of auto execution.

Example:

To set auto execution

- STEP 1. Press AUTO key (the light of AUTO is on)
- STEP 2. Press LOAD ON/OFF to proceed auto execution

4. CALIBRATION PROCEDURES

Instruments: 2 sets of DMM(digital multiple meters with 5 1/2 digits);
3 sets of POWER SUPPLY(60V, 6A; 8V, 75A; and 18V, 20A);
1 set of COUNTER (frequency counter).

4-1 Adjusting the reference voltage of C.V. MODE

- ❶ Press SHIFT and C.V. MODE, then key in 3, 8, 0, 1, and ↵ .
- ❷ When MEMORY indicates “01” and A indicates “CL01”, short the input terminal of the electronic load and press ↵ .
- ❸ When MEMORY indicates “02”, set the voltage of POWER SUPPLY to around 60V and the current of it to 0.8A.
- ❹ Connect the output terminal of POWER SUPPLY to the input terminal of the electronic load.
- ❺ Test the input terminal of load by the 200V range of a DMM. Adjust the POWER SUPPLY until the DMM display reads 60.00V. Adjust SVR401 to make the voltage of load to be 60.00V.
- ❻ Press ↵ .

Note : Applied instruments -- POWER SUPPLY (60V, 6A); DMM (5 1/2 digits)
Applied situation -- Voltage readings of the electronic load are not consistent with the true values.

4-2 Adjusting the reference voltage in 10Ω~1kΩ range of C.R. MODE

- ➊ Set voltage of POWER SUPPLY to 60V and current of it to 1A.
- ➋ Connect the output terminal of POWER SUPPLY to the input terminal of electronic load.
- ➌ Press SHIFT and C.V. MODE, then key in 3, 8, 0, 2, and ↵.
- ➍ Test the input terminal of load by the 200V range of a DMM. Adjust the POWER SUPPLY until the DMM display reads 60.00V. Use the 20V range of another DMM to test TP1 of a PCB.
- ➎ When MEMORY indicates "01" and A indicates "CL02", key in the voltage reading (no less than 6 digits including decimal) of TP1 (in unit of "V") and press ↵.
- ➏ When MEMORY indicates "02", key in the voltage reading (no less than 7 digits including decimal) of TP1 (in unit of "V") and press ↵.
- ➐ When MEMORY indicates "03", key in the voltage reading (no less than 7 digits including decimal) of TP1 (in unit of "V") and press ↵.

Note: Applied instruments -- POWER SUPPLY (60V, 6A); DMM (5 1/2 digits)
Applied situation -- The C.R. MODE in 10Ω~1kΩ range is not reliable.

4-3 Calibrating the D/A in 10Ω range of C.R. MODE

- ➊ Set voltage of POWER SUPPLY to 17V and current of it to 20A.
- ➋ Connect the output terminal of POWER SUPPLY to a DMM in 20A range in series. Hook up the DMM with the input terminal of the electronic load.
- ➌ Test the input terminal of the load by the 20V range of a DMM. Press SHIFT & C.V. MODE, key in 3,8,0,3, and ↵. Then adjust the POWER SUPPLY until the DMM display reads 17.00V.

- ④ When MEMORY indicates “01” and A indicates “CL03”, key in the current reading (no less than 6 digits including decimal) of the DMM (in unit of “A”) and press ↵ .
- ⑤ When MEMORY indicates “02”, key in the current reading (no less than 5 digits including decimal) of the DMM (in unit of “A”) and press ↵ .
- ⑥ When MEMORY indicates “03”, key in the current reading (no less than 5 digits including decimal) of the DMM (in unit of “A”) and press ↵ .
- ⑦ When MEMORY indicates “04”, key in the current reading (no less than 5 digits including decimal) of the DMM (in unit of “A”) and press ↵ .

Note: Applied instruments -- POWER SUPPLY (18V, 20A); DMM (5 1/2 digits)
Applied situation --The C.R. MODE in 10Ω range is not reliable.

4-4 Calibrating the OFFSET of C.R. MODE

- ① Set voltage of POWER SUPPLY to 3V and current of it to 0.5A
- ② Connect the output terminal of POWER SUPPLY to a DMM in 2A range in series. Then hook up the DMM with the input terminal of the electronic load.
- ③ Test the input terminal of the load by the 20V range of a DMM. Adjust the POWER SUPPLY until the DMM display reads 3.00V.
- ④ Set C.R. MODE to 10Ω (①select C.R. MODE; ② press V.I.R. SET; ③ key in “1”, “0”; ④ press ↵) first, then set the load to LOAD ON status.
- ⑤ adjust the POWER SUPPLY until the DMM display reads 0.300A.

Note: Applied instruments -- POWER SUPPLY (60V, 6A); DMM (5 1/2 digits)

4-5 Calibrating the D/A of C.V. MODE

- ➊ Set voltage of POWER SUPPLY to 62V and current of it to 0.5A.
- ➋ Connect the output terminal of POWER SUPPLY to the input terminal of electronic load.
- ➌ Test the input terminal of the load by the 200V range of a DMM. Pursue a reading of 62.00V from the DMM.
- ➍ Press SHIFT and C.V. MODE, then key in 3, 8, 0, 4, and ↵.
- ➎ When MEMORY indicates "01" and A indicates "CL04", key in the voltage reading (5 digits including decimal) of the DMM (in unit of "V") and press ↵.
- ➏ When MEMORY indicates "02", key in the voltage reading (5 digits including decimal) of the DMM (in unit of "V") and press ↵.
- ➐ When MEMORY indicates "03", key in the voltage reading (5 digits including decimal) of the DMM (in unit of "V") and press ↵.

Note: Applied instruments -- POWER SUPPLY (60V, 6A); DMM (5 1/2 digits)
Applied situation --The readings of the C.V. MODE are not reliable.

4-6 Calibrating the D/A, A/D in 6A range of C.C. MODE

- ➊ Set voltage of POWER SUPPLY to 30V and current of it to 6.2A.
- ➋ Connect the output terminal of POWER SUPPLY to a DMM in 20A range in series. Hook up the DMM with the input terminal of electronic load.

- ③ Test the input terminal of the load by the 200V range of a DMM. Press SHIFT and C.V. MODE, then key in 3, 8, 0, 5, and ↵ .
- ④ Adjust the POWER SUPPLY until the DMM display reads 30.00V.
- ⑤ When MEMORY indicates “01” and A indicates “CL05”, key in the current reading (no less than 5 digits including decimal) of the DMM (in unit of “A”) and press ↵ .
- ⑥ When MEMORY indicates “02”, key in the current reading (no less than 6 digits including decimal) of the DMM (in unit of “A”) and press ↵ .

Note: Applied instruments -- POWER SUPPLY (60V, 6A); DMM (5 1/2 digits)
Applied situation --The C.C. MODE in 6A range is not reliable.

4-7 Calibrating the D/A in 6A range of W SET

- ① Set the voltage of POWER SUPPLY to 50V and current of it to 6.2A.
- ② Connect the output terminal of POWER SUPPLY to a DMM in 20A range in series. Hook up the DMM with the input terminal of the electronic load.
- ③ Test the input terminal of the load by the 200V range of a DMM. Pursue a reading of 50.00V from the DMM by adjusting the POWER SUPPLY.
- ④ Press SHIFT and C.V. MODE, then key in 3, 8, 0, 6, and ↵ .
- ⑤ When MEMORY indicates “01” and A indicates “CL06”, the execution will be proceeded automatically by the pre-set program without key-in process.

Note: Applied instruments -- POWER SUPPLY (60V, 6A); DMM (5 1/2 digits)
Applied situation --The POWER SET in 6A range is not reliable.

4-8 Calibrating the D/A, A/D in 0.6A range of C.C. MODE

- ① Set voltage of POWER SUPPLY to 60V and current of it to 0.8A.
- ② Connect the output terminal of POWER SUPPLY to a DMM in 2A range in series. Hook up the DMM with the input terminal of the electronic load.
- ③ Test the input terminal of the load by the 200V range of a DMM. Press SHIFT and C.V. MODE, then key in 3, 8, 0, 7, and ↵.
- ④ Adjust the POWER SUPPLY until the DMM display reads 60.00V.
- ⑤ When MEMORY indicates "01" and A indicates "CL07", key in the current reading (no less than 6 digits including decimal) of the DMM (in unit of "A") and press ↵.
- ⑥ When MEMORY indicates "02", key in the current reading (no less than 7 digits including decimal) of the DMM (in unit of "A") and press ↵.

Note: Applied instruments -- POWER SUPPLY (60V, 6A); DMM (5 1/2 digits)
Applied situation --The readings of C.C. MODE in 0.6A range are not reliable.

4-9 Calibrating the D/A in 0.6A range of W SET

- ① Set voltage of POWER SUPPLY to 60V and current of it to 0.8A.
- ② Connect the output terminal of POWER SUPPLY to a DMM in 2A range in series. Hook up the DMM with the input terminal of the electronic load.
- ③ Test the input terminal of the load by the 200V range of a DMM. Press SHIFT and C.V. MODE, then key in 3, 8, 0, 8, and ↵.

- ④ Adjust the POWER SUPPLY until the DMM display reads 60.00V.
- ⑤ When MEMORY indicates "01" and A indicates "CL08", the execution will be proceeded automatically by the pre-set program without key-in process.

Note: Applied instruments -- POWER SUPPLY (60V, 6A); DMM (5 1/2 digits)
Applied situation --The POWER SET in 0.6A range is not reliable.

4-10 Calibrating the D/A, A/D in 60A range of C.C. MODE

- ① Set voltage of POWER SUPPLY to 5V and current of it to 75A.
- ② Connect the output terminal of POWER SUPPLY to a DMM in 75A range in series. Hook up the DMM with the input terminal of the electronic load.
- ③ Test the input terminal of the load by the 20V range of a DMM. Press SHIFT and C.V. MODE, then key in 3, 8, 0, 9, and ↵ .
- ④ Adjust the POWER SUPPLY until the DMM display reads 5.00V.
- ⑤ When MEMORY indicates "01" and A indicates "CL09", key in the current reading (no less than 6 digits including decimal) of the DMM (in unit of "A") and press ↵ .
- ⑥ When MEMORY indicates "02", key in the current reading (no less than 6 digits including decimal) of the DMM (in unit of "A") and press ↵ .

Note: Applied instruments -- POWER SUPPLY (8V, 75A); DMM (5 1/2 digits)
Applied situation --The C.C. MODE in 60A range is not reliable.

4-11 Calibrating the D/A in 60A range of W SET

- ① Set voltage of POWER SUPPLY to 5V and current of it to 75A.
- ② Connect the output terminal of POWER SUPPLY to a DMM in 75A range in series. Hook up the DMM with the input terminal of the electronic load.
- ③ Test the input terminal of the load by the 20V range of a DMM. Press SHIFT and C.V. MODE, then key in 3, 8, 1, 0, and \downarrow .
- ④ Adjust the POWER SUPPLY until the DMM display reads 5.00V.
- ⑤ When MEMORY indicates "01" and A indicates "CL10", the execution will be proceeded automatically by the pre-set program without key-in process.

Note: Applied instruments -- POWER SUPPLY (8V, 75A); DMM (5 1/2 digits)
Applied situation --The POWER SET in 60A range is not reliable.

4-12 Calibrating the reference voltage in 1 Ω range of C.R. MODE

- ① Set voltage of POWER SUPPLY to 17V and current of it to 1A.
- ② Connect the output terminal of POWER SUPPLY to the input terminal of the electronic load. Hook up a DMM in 200V range with the input terminal of the load. Press SHIFT and C.V. MODE, then key in 3, 8, 1, 1, and \downarrow . Pursue a reading of 17.00V from the DMM by adjusting the POWER SUPPLY.
- ③ Measure TP1 of PCB with another DMM in 20V range.
- ④ When MEMORY indicates "01" and A indicates "CL11", key in the voltage reading of TP1 (no less than 6 digits including decimal) of the DMM (in unit of "V") and press \downarrow .
- ⑤ When MEMORY indicates "02", key in the voltage reading of TP1 (no less than 7 digits including decimal) of the DMM (in unit of "V") and press \downarrow .

- ⑥ When MEMORY indicates “03”, key in the voltage reading of TP1 (no less than 7 digits including decimal) of the DMM (in unit of “V”) and press \downarrow .

Note: Applied instruments -- POWER SUPPLY (60V, 6A); DMM (5 1/2 digits)
Applied situation -- The readings of C.R. MODE are not reliable.

4-13 Calibrating the D/A in 1k Ω range of C.R. MODE

- ① Set voltage of POWER SUPPLY to 60V and current of it to 1A.
- ② Connect the output terminal of POWER SUPPLY to a DMM in 2A range in series. Hook up the DMM with the input terminal of the electronic load.
- ③ Test the input terminal of the load by the 200V range of a DMM. Press SHIFT and C.V. MODE, then key in 3,8,1,2,and \downarrow . Pursue a reading of 60.00V from DMM by adjusting the POWER SUPPLY.
- ④ When MEMORY indicates “01” and A indicates “CL12”, key in the current reading (no less than 6 digits including decimal) of the DMM (in unit of “A”) and press \downarrow .
- ⑤ When MEMORY indicates “02”, key in the current reading (no less than 7 digits including decimal) of the DMM (in unit of “A”) and press \downarrow .
- ⑥ When MEMORY indicates “03”, key in the current reading (no less than 7 digits including decimal) of the DMM (in unit of “A”) and press \downarrow .
- ⑦ When MEMORY indicates “04”, key in the current reading (no less than 7 digits including decimal) of the DMM (in unit of “A”) and press \downarrow .

Note: Applied instruments -- POWER SUPPLY (60V, 6A); DMM (5 1/2 digits)
Applied situation -- The readings of C.R. MODE are not reliable.

4-14 Calibrating the D/A in 100Ω range of C.R. MODE

- ❶ Set voltage of POWER SUPPLY to 40V and current of it to 6.2A.
- ❷ Connect the output terminal of POWER SUPPLY to a DMM in 20A range in series. Then hook up the DMM with the input terminal of the electronic load.
- ❸ Test the input terminal of the load by the 200V range of a DMM. Press SHIFT and C.V. MODE, then key in 3, 8, 1, 3, and ↵. Adjust the POWER SUPPLY until the DMM display reads 40.
- ❹ When MEMORY indicates "01" and A indicates "CL13", key in the current reading (no less than 6 digits including decimal) of the DMM (in unit of "A") and press ↵.
- ❺ When MEMORY indicates "02", key in the current reading (no less than 6 digits including decimal) of the DMM (in unit of "A") and press ↵.
- ❻ When MEMORY indicates "03", key in the current reading (no less than 6 digits including decimal) of the DMM (in unit of "A") and press ↵.
- ❼ When MEMORY indicates "04", key in the current reading (no less than 6 digits including decimal) of the DMM (in unit of "A") and press ↵.

Note: Applied instruments -- POWER SUPPLY (60V, 6A); DMM (5 1/2 digits)
Applied situation -- The readings of C.R. MODE are not reliable.

4-15 Calibrating the D/A in 1Ω range of C.R. MODE

- ❶ Set voltage of POWER SUPPLY to 5V and current of it to 75A.
- ❷ Connect the output terminal of POWER SUPPLY to a DMM in 75A range in series. Then hook up the DMM with the input terminal of the electronic load.
- ❸ Test the input terminal of the load by the 20V range of a DMM. The readout should be 5.00V.
- ❹ Press SHIFT and C.V. MODE, then key in 3, 8, 1,4, and ↵. Then adjust the POWER SUPPLY until the DMM display reads 5.00V.
- ❺ When MEMORY indicates "01" and A indicates "CL14", key in the current reading (no less than 5 digits including decimal) of the DMM (in unit of "A") and press ↵.
- ❻ When MEMORY indicates "02", key in the current reading (no less than 5 digits including decimal) of the DMM (in unit of "A") and press ↵.
- ❼ When MEMORY indicates "03", key in the current reading (no less than 5 digits including decimal) of the DMM (in unit of "A") and press ↵.
- ❽ When MEMORY indicates "04", key in the current reading (no less than 5 digits including decimal) of the DMM (in unit of "A") and press ↵.

Note: Applied instruments -- POWER SUPPLY (8V, 75A); DMM (5 1/2 digits)
Applied situation -- The readings of C.R. MODE are not reliable.

4-16 Calibrating the 100Hz~1kHz range of SW MODE

- ❶ Set voltage of POWER SUPPLY to 60V and current of it to 1A.
- ❷ Connect the positive output terminal of POWER SUPPLY to a 0.1Ω 5W concrete resistance first, then connect the resistance to the input terminal of electronic load. Hook up a DMM in 200V range with the input terminal of the load. Connect the input terminal of COUNTER to both ends of the concrete resistance.
- ❸ Test the input terminal of the load by the 200V range of a DMM. Press SHIFT and C.V. MODE, then key in 3, 8, 1,5, and ↵. Then adjust the POWER SUPPLY until the DMM display reads 60.00V.
- ❹ When MEMORY indicates "01" and A indicates "CL15", key in the frequency reading (7 digits including decimal) of the COUNTER (in unit of "Hz") and press ↵.
- ❺ When MEMORY indicates "02", key in the frequency reading (7 digits including decimal) of the COUNTER (in unit of "Hz") and press ↵.
- ❻ When MEMORY indicates "03", key in the frequency reading (7 digits including decimal) of the COUNTER (in unit of "Hz") and press ↵.
- ❼ When MEMORY indicates "04", key in the frequency reading (7 digits including decimal) of the COUNTER (in unit of "Hz") and press ↵.
- ❽ When MEMORY indicates "05", key in the frequency reading (7 digits including decimal) of the COUNTER (in unit of "Hz") and press ↵.
- ❾ When MEMORY indicates "06", key in the frequency reading (7 digits including decimal) of the COUNTER (in unit of "Hz") and press ↵.

Note: Applied instruments -- POWER SUPPLY(60V, 6A); DMM(5 1/2 digits); COUNTER(frequency counter)
Applied situation -- The readings of FREQ. and DUTY are not reliable.

4-17 Calibrating the D/A in 10Hz~100Hz range of SW MODE

- ❶ Set voltage of POWER SUPPLY to 60V and current of it to 1A.
- ❷ Connect the positive output terminal of POWER SUPPLY to a 0.1Ω 5W concrete resistance first, then connect the resistance to the input terminal of the electronic load. Hook up a DMM in 200V range with the input terminal of the load. Connect the input terminal of COUNTER to both ends of the concrete resistance.
- ❸ Test the input terminal of the load by the 200V range of a DMM. Press SHIFT and C.V. MODE, then key in 3, 8, 1,6, and \downarrow . Then adjust the POWER SUPPLY until the DMM display reads 60.00V.
- ❹ When MEMORY indicates “01” and A indicates “CL16”, key in the frequency reading (7 digits including decimal) of the COUNTER (in unit of “Hz”) and press \downarrow .
- ❺ When MEMORY indicates “02”, key in the frequency reading (7 digits including decimal) of the COUNTER (in unit of “Hz”) and press \downarrow .
- ❻ When MEMORY indicates “03”, key in the frequency reading (7 digits including decimal) of the COUNTER (in unit of “Hz”) and press \downarrow .
- ❼ When MEMORY indicates “04”, key in the frequency reading (7 digits including decimal) of the COUNTER (in unit of “Hz”) and press \downarrow .
- ❽ When MEMORY indicates “05”, key in the frequency reading (7 digits including decimal) of the COUNTER (in unit of “Hz”) and press \downarrow .
- ❾ When MEMORY indicates “06”, key in the frequency reading (7 digits including decimal) of the COUNTER (in unit of “Hz”) and press \downarrow .

Note: Applied instruments -- POWER SUPPLY (60V, 6A); DMM (5 1/2 digits);
COUNTER (frequency counter)

Applied situation --The readings of FREQ. and DUTY are not reliable.

4-18 Calibrating the D/A in 1Hz~10Hz range of SW MODE

- ❶ Set voltage of POWER SUPPLY to 60V and current of it to 1A.
- ❷ Connect the positive output terminal of POWER SUPPLY to a 0.1Ω 5W concrete resistance first, then connect the resistance to the input terminal of the electronic load. Hook up a DMM in 200V range with the input terminal of the load. Connect the input terminal of COUNTER to both ends of the concrete resistance.
- ❸ Test the input terminal of load by the 200V range of a DMM. Press SHIFT & C.V. MODE, then key in 3,8,1,7, and \downarrow . Adjust the POWER SUPPLY until the DMM display reads 60..
- ❹ When MEMORY indicates "01" and A indicates "CL17", key in the frequency reading (7 digits including decimal) of the COUNTER (in unit of "Hz") and press \downarrow .
- ❺ When MEMORY indicates "02", key in the frequency reading (7 digits including decimal) of the COUNTER (in unit of "Hz") and press \downarrow .
- ❻ When MEMORY indicates "03", key in the frequency reading (7 digits including decimal) of the COUNTER (in unit of "Hz") and press \downarrow .
- ❼ When MEMORY indicates "04", key in the frequency reading (7 digits including decimal) of the COUNTER (in unit of "Hz") and press \downarrow .
- ❽ When MEMORY indicates "05", key in the frequency reading (7 digits including decimal) of the COUNTER (in unit of "Hz") and press \downarrow .
- ❾ When MEMORY indicates "06", key in the frequency reading (7 digits including decimal) of the COUNTER (in unit of "Hz") and press \downarrow .

Note: Applied instruments -- POWER SUPPLY (60V, 6A); DMM (5 1/2 digits); COUNTER (frequency counter)
Applied situation --The readings of FREQ. and DUTY are not reliable.

4-19 D/A Calibrating the SENSE current offset of C.C., C.R. MODE

- ❶ Set voltage of POWER SUPPLY to 60V and current of it to 1A.
- ❷ Connect the output terminal of POWER SUPPLY to a DMM in 2A range in series. Hook up the DMM with the input terminal of the load.
- ❸ Test the input terminal of the load by the 200V range of a DMM. Press SHIFT and C.V. MODE, then key in 3, 8, 1, 8, and ↵. Adjust the POWER SUPPLY until the DMM display reads 60.00V.
- ❹ When MEMORY indicates "01" and A indicates "CL18", key in the current reading (7 digits including decimal) of the DMM (in unit of "A") and press ↵.
- ❺ When MEMORY indicates "02", key in the current reading (7 digits including decimal) of the DMM (in unit of "A") and press ↵.
- ❻ When MEMORY indicates "03", key in the current reading (7 digits including decimal) of the DMM (in unit of "A") and press ↵.
- ❼ When MEMORY indicates "04", key in the current reading (7 digits including decimal) of the DMM (in unit of "A") and press ↵.

Note: Applied instruments -- POWER SUPPLY (60V, 6A); DMM (5 1/2 digits).

5. APPLICATION

5-1 The Table of the error message

Code	Cause	Resolvent
Err-01	Input voltage over 60V	Lower the input voltage
Err-02	Input power exceeds setting	Set higher power value or lower the voltage and current
Err-03	Input voltage and power exceed setting	Lower the input voltage and set a higher power value
Err-04	Input current exceeds setting	Lower the input current
Err-05	Input voltage and current exceed setting	Same as Err-01 and Err-04
Err-06	Input current and power exceed setting	Same as Err-02 and Err-04
Err-07	Input voltage, current and power exceed setting	Same as ERR-01, Err-02 and Err-04
Err-08	Error of the adjusting data when performing CHECKSUM	Send the instrument back to the manufacturer for adjustment or adjust by yourself.
Err-09	Error inaccurate when performing CHECKSUM	Send the instrument back to the manufacturer for repair
Err-10	The time of running AUTO has not been set	Re-set the time of execution
Err-11	Key-in value exceeds input range	Key in the value again
Err-12	The setting of STEP exceeds the resolution of the range between chosen	Set the value of STEP again
Err-13	The setting of STEP exceeds output range	Set the value of V.I.R. again

To clear the Error Message: [SHIFT] + [C.C. MODE]

5-2 Test Lead

The Selection of Output Test Lead and Feedback Test Lead:

For safety assurance, please select the adequate output test lead according to the following list:

UL (CSA) Model	Conductor				Maximum Conductive Resistor Ω/km	Permissible Current A(amp)
	Wire No. AWG	Component pc/mm	Cross Section Area (mm^2)	Outer Diameter mm		
1015 TEW (Twisted Wire)	24	11/0.16	0.22	0.64	88.6	7.64
	22	17/0.16	0.34	0.78	62.5	10.0
	20	21/0.18	0.53	0.95	39.5	13.1
	18	34/0.18	0.87	1.21	24.4	17.2
	16	26/0.254	1.32	1.53	15.6	22.6
	14	41/0.254	2.08	2.03	9.90	30.4
	12	65/0.254	3.29	2.35	6.24	40.6
	10	65/0.32	5.23	3.00	3.90	55.3

Remark:

1. The ambient temperature of “Permissible Current” is at 40°C , the withstanding temperature of conductor is at 105°C according to the condition of the distributed single wire.
2. The permissible current listed as above is suggested to be used under 70%.
3. If the feedback test leads are in need, the level above UL(CSA) AWG24, 22, 20... can be accepted. Besides, when the load is a capacitive load, please use the twin wire by twisting (+)output test lead with (S+) feedback test lead. Same way used on (-) output test lead and (S-) feedback test lead.
4. When the current value exceeds above suggestive list, can select more wires used in parallel according to above list.

6. SAFETY SUMMARY

SAFETY TERMS AND SYMBOLS:

These terms may appear in this manual or on the product:



WARNING. Warning statements identify condition or practices that could result in injury or loss of life.



CAUTION. Caution statements identify conditions or practices that could result in damage to this product or other property.



WARNING: This equipment is not for measurements performed for CAT II, III and IV.

Measurement category I is for measurements performed on circuits not directly connected to MAINS.

Measurement category II is for measurements performed on circuits directly connected to the low voltage installation.

Measurement category III is for measurements performed in the building installation.

Measurement category IV is for measurements performed at the source of the low-voltage installation.

The following symbols may appear in this manual or on the product:



DANGER
High Voltage



ATTENTION
refer to Manual



Protective
Conductor Terminal



Functional Earth
Terminal

FOR UNITED KINGDOM ONLY

NOTE: This lead/appliance must only be wired by competent person.

WARNING: THIS APPLIANCE MUST BE EARTHED

IMPORTANT: The wires in this lead are coloured in accordance with the following code:

Green/ Yellow:	Earth
Blue:	Neutral
Brown:	Live (Phase)

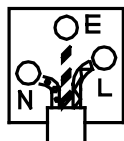

As the colours of the wires in main leads may not correspond with the colours marking identified in your plug/appliance, proceed as follows:

The wire which is coloured Green & Yellow must be connected to the Earth terminal marked with the letter E or by the earth symbol  or coloured Green or Green & Yellow.

The wire which is coloured Blue must be connected to the terminal which is marked with the letter N or coloured Blue or Black.

The wire which is coloured Brown must be connected to the terminal marked with the letter L or P or coloured Brown or Red. If in doubt, consult the instructions provided with the equipment or contact the supplier.

This cable/appliance should be protected by a suitably rated and approved HBC mains fuse: refer to the rating information on the equipment and/or user instructions for details. As a guide, cable of 0.75mm² should be protected by a 3A or 5A fuse. Larger conductors would normally require 13A types, depending on the connection method used.

Any moulded mains connector that requires removal /replacement must be destroyed by removal of any fuse & fuse carrier and disposed of immediately, as a plug with bared wires is hazardous if an engaged in live socket. Any re-wiring must be carried out in accordance with the information detailed on this label.



WARNING: For continued fire protection, replace fuse only with the specific type and rating by qualified personnel. Disconnect the power cord before replacing fuse.

Cleaning the Cabinet

Disconnect the AC power cord before cleaning the instrument.

Use a soft cloth dampened in a solution of mild detergent and water. Do not spray cleaner directly onto the instrument, since it may leak into the cabinet and cause damage.

Do not use chemicals containing benzene, benzene, toluene, xylene, acetone, or similar solvents.



GW assumes no responsibility for its product being used in a hazardous or dangerous manner either alone or in conjunction with other equipment. High voltage and high pulse current used in some instruments may be dangerous if misused.



**205 Westwood Ave
Long Branch, NJ 07740
1-877-742-TEST (8378)
Fax: (732) 222-7088
salesteam@Equipment.NET**