

Keithley Instruments, Inc.

28775 Aurora Road
Cleveland, Ohio 44139
1-888-KEITHLEY

<http://www.keithley.com>



Description

The Model 2657A-PM-200 Protection Module (PM) is a stand-alone module that protects certain lower-voltage source-measure units (SMUs) that are part of a testing configuration from damage by voltage sources that are greater than 220 V.

Figure 1: Model 2657A-PM-200



The protection module is designed for use with the following lower voltage SMUs:

- Model 2611A Single-Channel System SourceMeter® Instrument
- Model 2612A Dual-Channel System SourceMeter® Instrument
- Model 2635A Single-Channel System SourceMeter® Instrument
- Model 2636A Dual-Channel System SourceMeter® Instrument
- Model 4200-SCS Semiconductor Characterization System SMUs:
 - Model 4200-SMU Medium Power Source-Measure Unit (with or without the Model 4200-PA Remote PreAmp Option)
 - Model 4210-SMU High Power Source-Measure Unit (with or without the Model 4200-PA Remote PreAmp Option)

The protection module is intended for use in applications where a device breakdown or other potential failure could connect the high-voltage output of the Model 2657A High Power System SourceMeter® Instrument to a lower voltage SMU.



CAUTION

The Model 2657A-PM-200 does not protect the Model 2601A Single-Channel System SourceMeter® Instrument or the Model 2602A Dual-Channel System SourceMeter® Instrument. Do not use the protection module with these source-measure instruments.

⚠ CAUTION

To prevent damage to the Model 2657A-PM-200 in the case of device failure, the current from the high-voltage source should be limited to 120 mA or less.

⚠ WARNING

The Model 2657A-PM-200 protection module must be connected to protective earth (safety ground) using the the supplied green-yellow ground cables (Model CA-568). Connection of both ground cables to protective earth are necessary for safety.

Figure 2: Model 2657A-PM-200 grounding
High voltage triaxial connectors

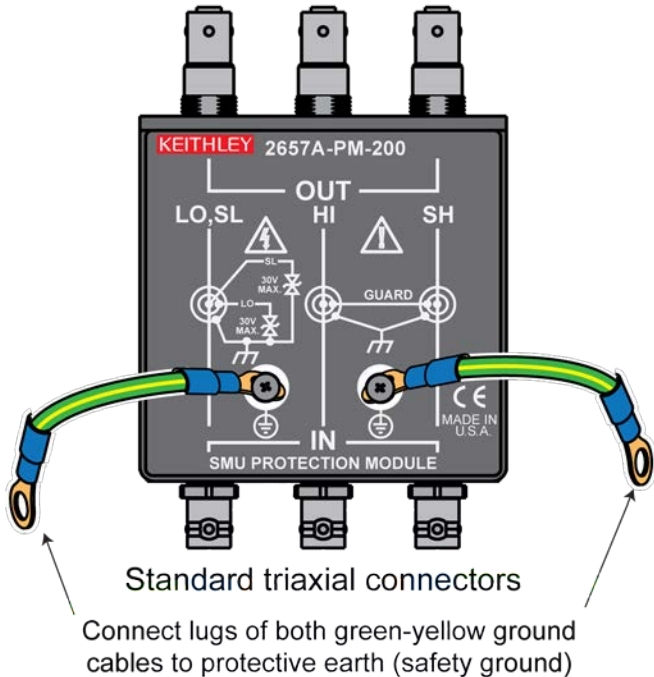

The standard triaxial IN connectors are used for connection to the SMU. Maximum clamped voltage on the IN connectors is 240 VDC. The high voltage triaxial connectors are used for connection to the device under test. Do not exceed 3280 V on the OUT connectors.

- The center conductor of the LO,SL connectors is sense LO and the inner shield is LO. The outer shield (shell) is chassis ground.
- The center conductor of the HI connectors is HI and the inner shield is guard. The outer shield (shell) is chassis ground.
- The center conductor of the SH connectors is sense HI and the inner shield is guard. The outer shield (shell) is chassis ground.

Connections using a Model 2611A or 2612A SMU

Required accessories:

- One Model 2600-TRIAX adapter per channel
- Two or three standard triaxial cables (either Model 7078-TRX or 4200-TRX) per channel
- Two or three high-voltage (HV) triaxial cables (Model CA-553 or CA-554) per channel

Connection summary

Use the connection drawing below to connect source-measure unit (SMU) channels of the Model 2611A or 2612A to the Model 2657A-PM-200. For each channel, make sure to use the IN connectors of the the Model 2657A-PM-200 for connection to the Model 2600-TRIAX and use the OUT connectors for connection to the device under test (DUT).

The drawing shows connections for 4-wire sensing. For 2-wire applications, the SH (sense HI) connectors of the Model 2657A-PM-200 are not used.

NOTE

Connecting the Model 2600-TRIAX to the Model 2657A-PM-200 connects the LO terminal of the Model 2611A or 2612A to protective earth (safety ground).



CAUTION

Do not convert triaxial cables to BNC cables. Using BNC cables removes protection from the Model 2611A or 2612A and may result in damage to the SMU. You must use triaxial cables to connect to the lower-voltage SMU.

NOTE

When using the 2657A-PM-200, HI and SH (sense HI) should be connected together at the device under test. A potential difference between the two circuits in excess of 100 mV may result in compromised measurements.

Large potential differences can be created when there is significant lead resistance and current flowing in the HI lead. To minimize lead resistance, minimize the distance between the Model 2657A-PM-200 and the device under test.

Figure 4: Connections for a Model 2611A or 2612A

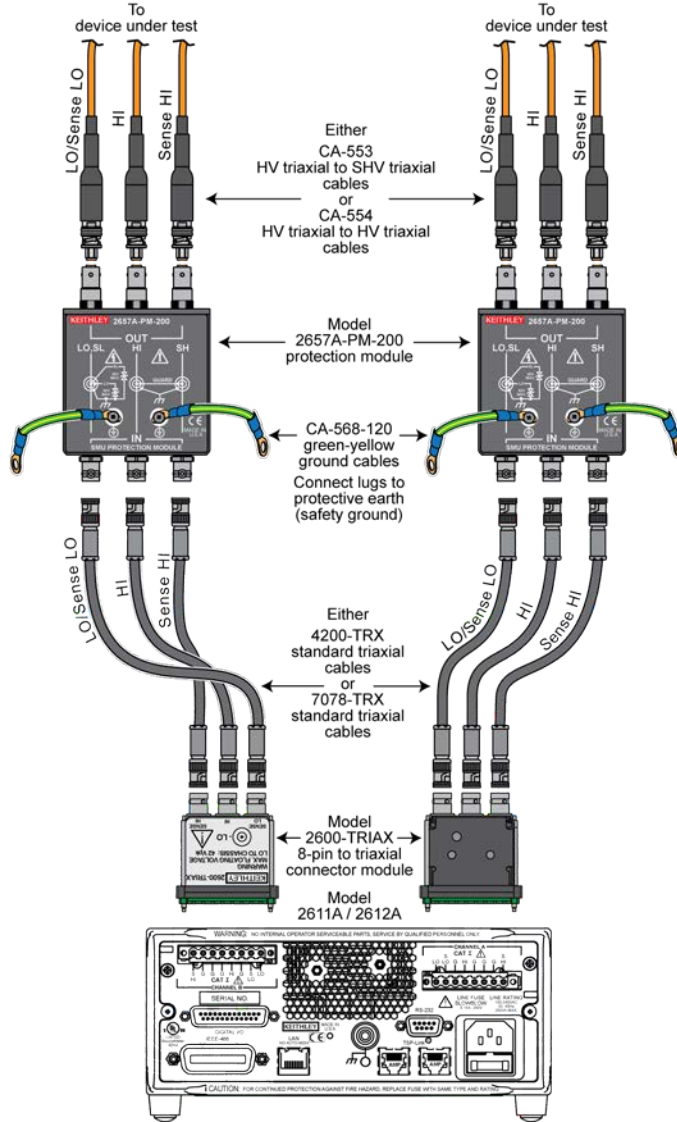

Connections using a Model 2635A or 2636A SMU

Required accessories:

- Two or three standard triaxial cables (either Model 7078-TRX or 4200-TRX) per source-measure unit (SMU) channel
- Two or three high-voltage (HV) triaxial cables (Model CA-553 or CA-554) per SMU channel

Connection summary

Use the connection drawing below to connect source-measure unit (SMU) channels of the Model 2635A or 2636A to the Model 2657A-PM-200. For each channel, make sure to use the IN connectors of the Model 2657A-PM-200 for connection to the Model 2635A or 2636A and use the OUT connectors for connection to the device under test (DUT).

The drawing shows connections for 4-wire sensing. For 2-wire applications, the SH (sense HI) connectors of the Model 2657A-PM-200 are not used.



CAUTION

Do not convert triaxial cables to BNC cables. Using BNC cables removes protection from the Model 2635A or 2636A and may result in damage to the SMU. You must use triaxial cables to connect to the lower-voltage SMU.

NOTE

When using the 2657A-PM-200, HI and SH (sense HI) should be connected together at the device under test. A potential difference between the two circuits in excess of 100 mV may result in compromised measurements.

Large potential differences can be created when there is significant lead resistance and current flowing in the HI lead. To minimize lead resistance, minimize the distance between the Model 2657A-PM-200 and the device under test.

Connections using a Model 4200-SCS SMU (with Model 4200-PA)

If ordered, a Model 4200-PA remote preamplifier (preamp) for a source-measure unit (SMU) is installed at the factory when the Model 4200-SCS is ordered.

Required accessories to connect one Model 4200-SMU or 4210-SMU (with the Model 4200-PA):

- Two or three Model 4200-TRX cables
- Two or three high-voltage (HV) triaxial cables (Model CA-553 or CA-554)

Connection summary

Use the connection drawing below to connect a Model 4200-PA preamp and the GNDU (ground unit) to the Model 2657A-PM-200. Make sure to use the IN connectors of the Model 2657A-PM-200 for connection to the Model 4200-SCS and use the OUT connectors for connection to the device under test (DUT).

The drawing shows connections for 4-wire sensing. For 2-wire applications, the SH (sense HI) connectors of the Model 2657A-PM-200 are not used.

NOTE

When using multiple SMUs that are installed in the Model 4200-SCS, each SMU needs its own protection module. To achieve adequate voltage protection, connect the GNDU Sense terminal to the LO,SL (LO and sense LO) connector of each protection module using triax tees (such as the Keithley Model 237-TRX-T) and additional triaxial cables (Model 4200-TRX).

NOTE

Connecting the Model 4200-SMU or 4210-SMU to the Model 2657A-PM-200 connects the LO terminal of the SMU to protective earth (safety ground).



CAUTION

Do not convert triaxial cables to BNC cables. Using BNC cables removes protection from the Model 4200-SCS SMU and may result in damage to the SMU. You must use triaxial cables to connect to the lower-voltage SMU.

NOTE

When using the Model 2657A-PM-200, HI and SH (sense HI) should be connected together at the device under test. A potential difference between the two circuits in excess of 100 mV may result in compromised measurements.

Large potential differences can be created when there is significant lead resistance and current flowing in the HI lead. To minimize lead resistance, minimize the distance between the Model 2657A-PM-200 and the device under test.

Figure 6: Connections for a Model 4200-SCS SMU (with preamp)

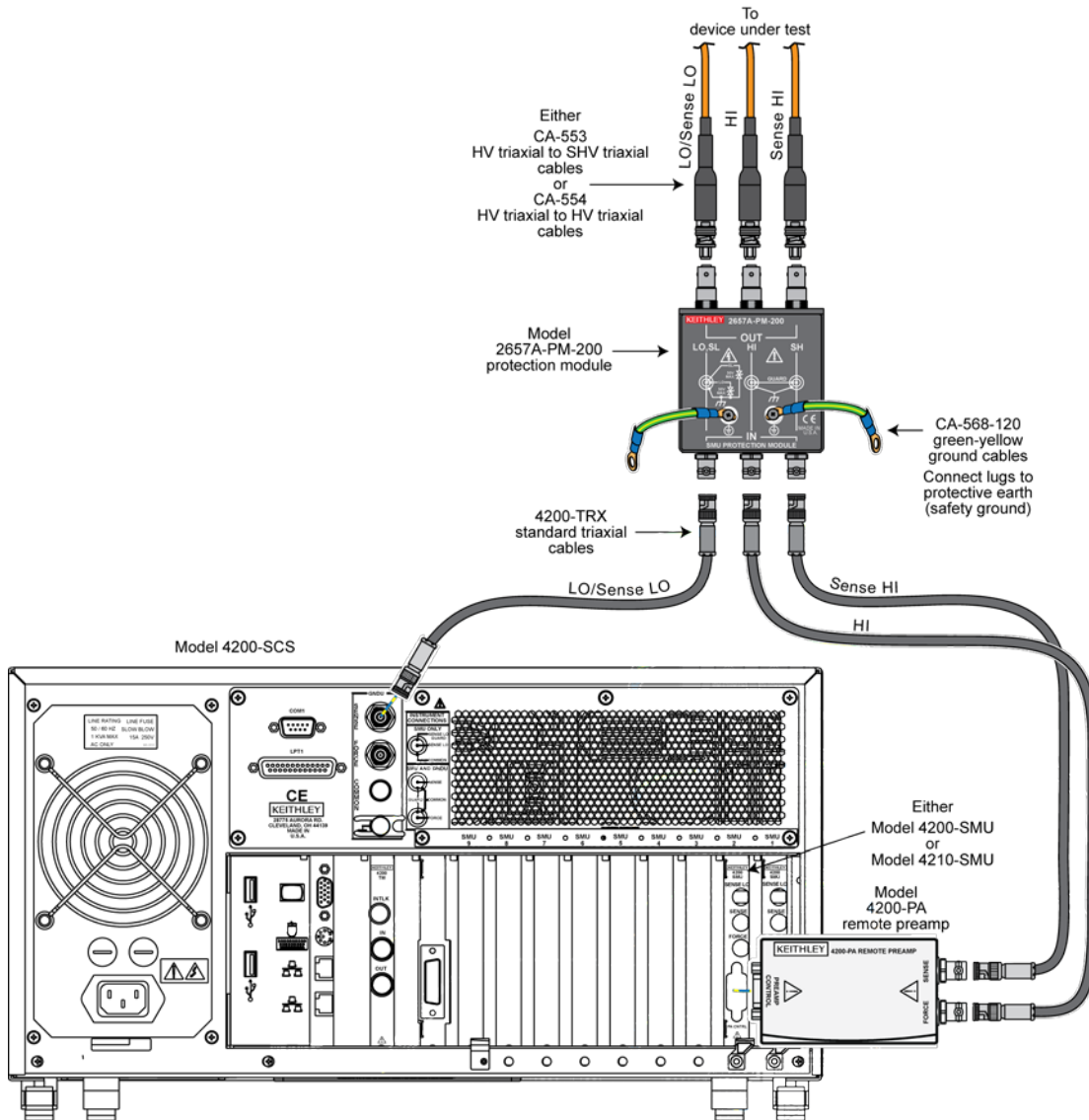

Connections using a Model 4200-SCS SMU

Required accessories to connect one Model 4200-SMU or 4210-SMU (without the Model 4200-PA Remote PreAmp):

- One Model 4200-TRX cable
- One or two Model 4200-MTRX cables
- Two or three high-voltage (HV) triaxial cables (Model CA-553 or CA-554)

Connection summary

Use the connection drawing below to connect a Model 4200-SMU or 4210-SMU and the GNDU (ground unit) to the Model 2657A-PM-200. Make sure to use the IN connectors of the Model 2657A-PM-200 for connection to the Model 4200-SCS and use the OUT connectors for connection to the device under test (DUT).

The drawing shows connections for 4-wire sensing. For 2-wire applications, the SH (sense HI) connectors of the Model 2657A-PM-200 are not used.

NOTE

When using multiple SMUs that are installed in the Model 4200-SCS, each SMU needs its own protection module. To achieve adequate voltage protection, connect the GNDU Sense terminal to the LO,SL (LO and sense LO) connector of each protection module using triax tees (such as the Keithley Model 237-TRX-T) and additional triaxial cables (Model 4200-TRX).

NOTE

Connecting the Model 4200-SMU or 4210-SMU to the Model 2657A-PM-200 connects the LO terminal of the SMU to protective earth (safety ground).

NOTE

When using the 2657A-PM-200, HI and SH (sense HI) should be connected together at the device under test. A potential difference between the two circuits in excess of 100 mV may result in compromised measurements.

Large potential differences can be created when there is significant lead resistance and current flowing in the HI lead. To minimize lead resistance, minimize the distance between the Model 2657A-PM-200 and the device under test.



Figure 7: Connections for a Model 4200-SCS SMU

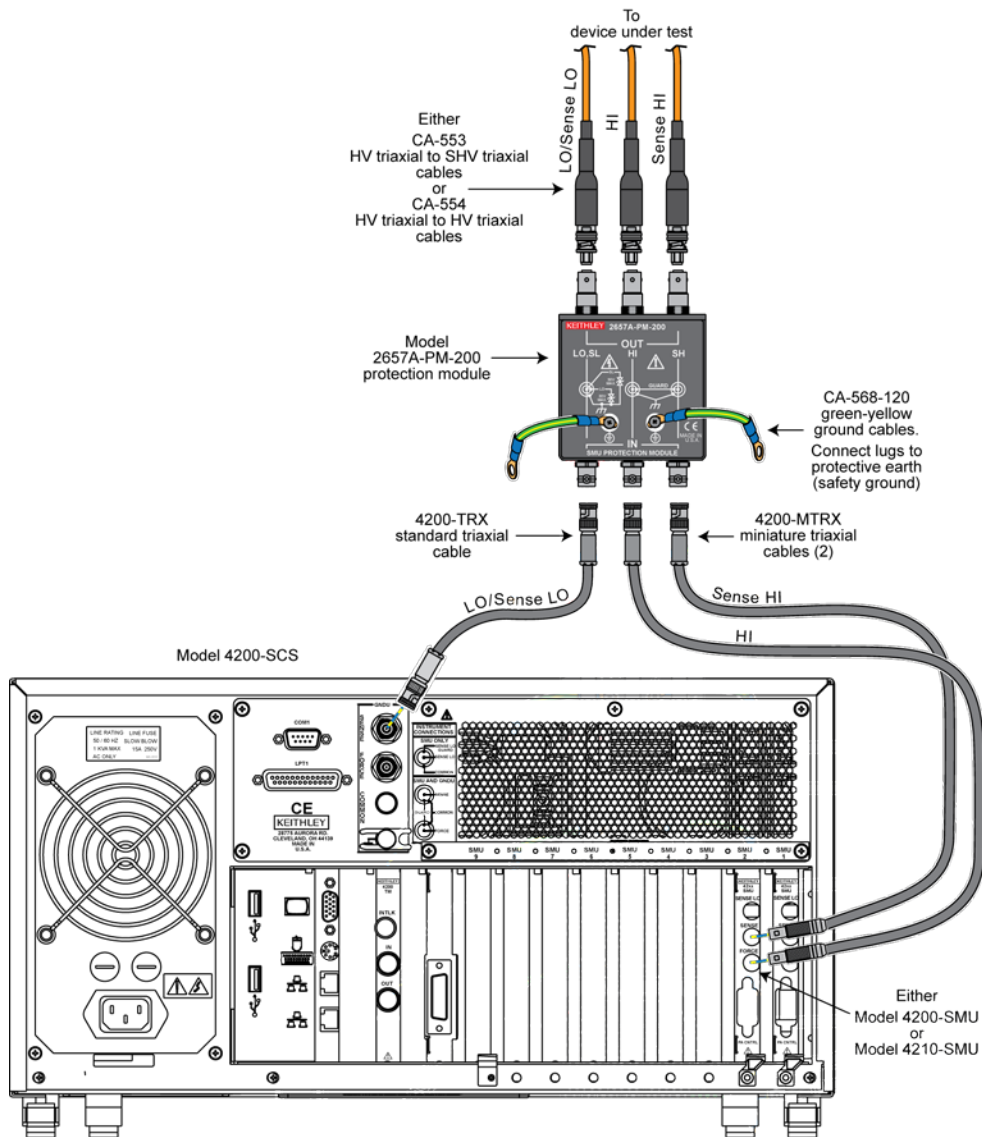

Verify Model 2657A-PM-200 operation

A simplified block diagram of the Model 2657A-PM-200 is shown below.

Figure 8: Simplified diagram of the Model 2657A-PM-200

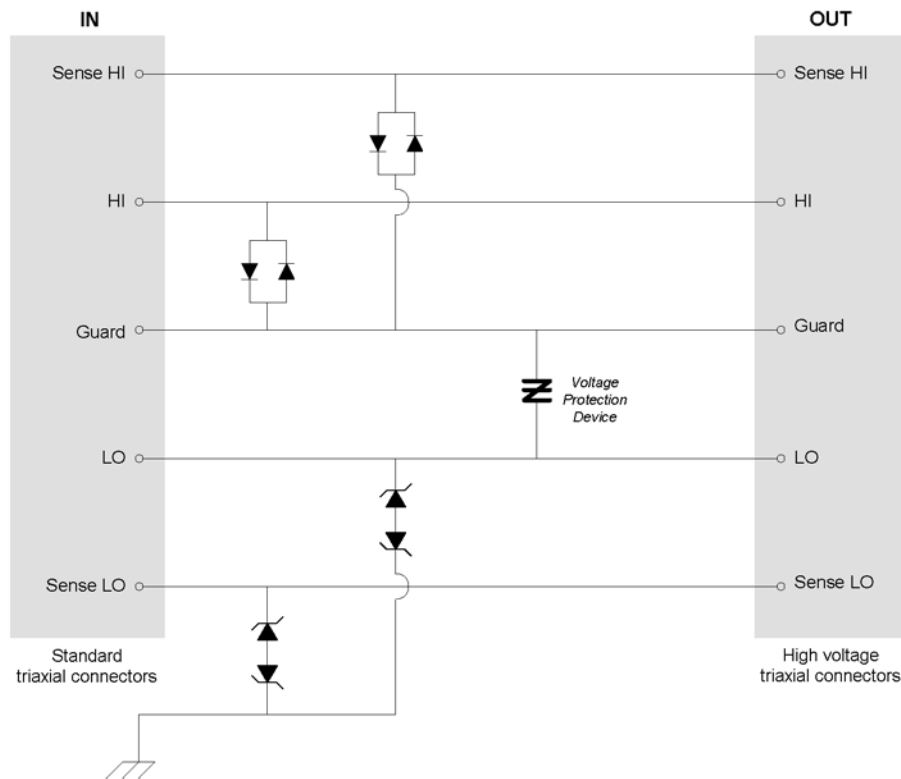

The voltage protection device is connected between Guard and LO. Low-leakage diodes are used to connect both HI and Sense HI to the Guard terminal. This enables the protection module to protect a SMU connected to the IN terminals from overvoltage.

The Zener diodes between LO and chassis and Sense LO and chassis limit the maximum voltage between LO and chassis ground to 30 V to 40 V.

Use the following procedures to verify that the Model 2657A-PM-200 is operating properly.

Verify diodes between HI / sense HI and guard

A Keithley SourceMeter® instrument capable of sourcing 10 mA at 10 V is required for verification procedures A and B.

Verification procedure A

Verify the operation of the diodes between Sense HI and Guard of the Model 2657A-PM-200:

1. As shown in the connection drawing below, connect the source-measure unit (SMU) to the SH triaxial connector of the protection module:
 - a. Connect the SMU Force HI terminal to the center conductor of the SH IN triaxial connector of the Model 2657A-PM-200.
 - b. Connect the SMU Force LO terminal to the inner shield of the SH IN triaxial connector of the Model 2657A-PM-200.

Figure 9: Connections for verification procedure A

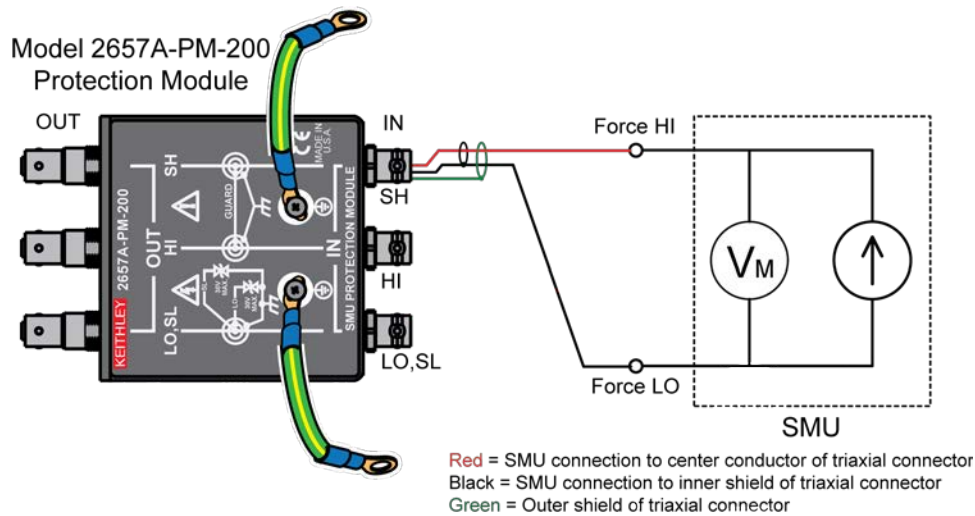

2. Configure the SMU to source current and measure voltage.
3. Program the current source level to 10 mA.
4. Set the voltage limit to 10 V.
5. Turn on the SMU output.
6. Verify that the voltage measured by the SMU is between 0.6 V and 1.0 V.
7. Program the SMU current source level to -10 mA.
8. Verify that the voltage measured is between -0.6 V and -1.0 V.

Verification procedure B

Verify the operation of the diodes between HI and Guard of the Model 2657A-PM-200:

1. As shown in the connection drawing below, connect the source-measure unit (SMU) to the HI triaxial connector of the protection module:
 - a. Connect the SMU Force HI terminal to the center conductor of the HI OUT triaxial connector of the Model 2657A-PM-200.
 - b. Connect the SMU Force LO terminal to the inner shield of the HI OUT triaxial connector of the Model 2657A-PM-200.

Figure 10: Connections for verification procedure B

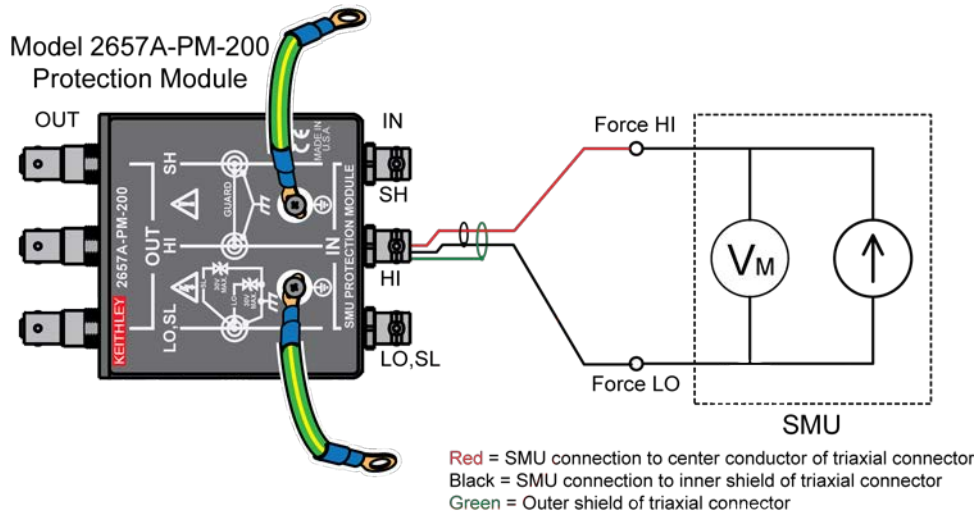

2. Configure the SMU to source current and measure voltage.
3. Program the current source level to 10 mA.
4. Set the voltage limit to 10 V.
5. Turn on the SMU output.
6. Verify that the voltage measured is between 0.6 V and 1.0 V.
7. Program the current source level to -10 mA.
8. Verify that the voltage measured is between -0.6 V and -1.0 V.

Verify diodes between LO / sense LO and chassis

A Keithley SourceMeter® instrument capable of sourcing 10 mA at 50 V is required for verification procedures C and D.

! WARNING

A safety shield must be used whenever hazardous voltages (>30 V RMS, 42 V peak) will be present in the test circuit. To prevent electrical shock that could cause injury or death, never use a Keithley SourceMeter® instrument in a test circuit that may contain hazardous voltages without a properly installed and configured safety shield. The following procedures show the use of a metal safety shield. Connect the enclosure of the metal test fixture to protective earth (safety ground).

If using a nonconductive test fixture, it must be rated to double the maximum capability of the test equipment in the system and the two green-yellow ground cables for the Model 2657A-PM-200 must be connected to protective earth (safety ground). Failure to attach the ground wires to a known protective earth may result in electric shock.

Verification procedure C

Verify the operation of the diodes between Sense LO and the chassis of the Model 2657A-PM-200:

1. As shown in the connection drawing below, connect the source-measure unit (SMU) to the SL triaxial connector of the protection module:
 - a. Connect the SMU force HI terminal to the center conductor of the SL OUT triaxial connector of the Model 2657A-PM-200.
 - b. Connect the SMU force LO terminal to the outer shield (chassis) of the SL OUT triaxial connector of the Model 2657A-PM-200. The chassis is available at the outer shield of any of the triaxial connectors on the Model 2657A-PM-200.

Figure 11: Connections for verification procedure C

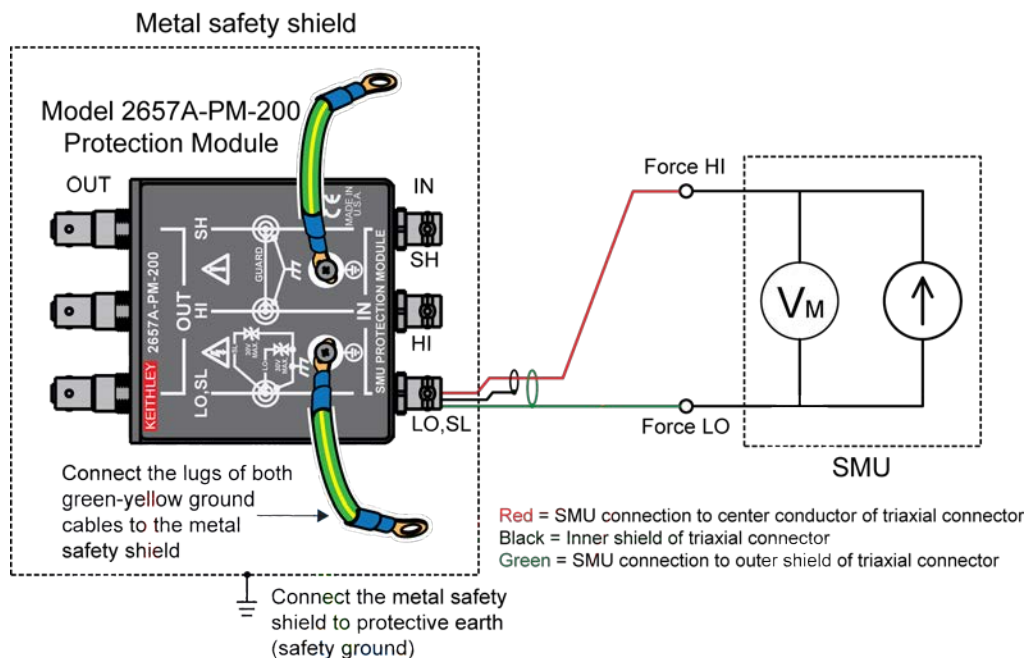

2. Configure the SMU to source current and measure voltage.
3. Program the current source level to 10 mA.
4. Set the voltage limit to 50 V.
5. Turn on the SMU output.
6. Verify that the voltage measured is between 30 V and 40 V.
7. Program the current source level of the SMU to -10 mA.
8. Verify that the voltage measured is between -30 V and -40 V.

Verification procedure D

Verify the operation of the diodes between LO and the chassis of the Model 2657A-PM-200:

1. As shown below, connect the SMU to the LO,SL triaxial connector of the protection module:
 - a. Connect the SMU force HI terminal to the inner shield of the LO,SL IN triaxial connector of the Model 2657A-PM-200.
 - b. Connect the SMU force LO terminal to the outer shield (chassis) of the LO,SL IN triaxial connector of the Model 2657A-PM-200. The chassis is available at the outer shield of any of the triaxial connectors on the Model 2657A-PM-200.

Figure 12: Connections for verification procedure D

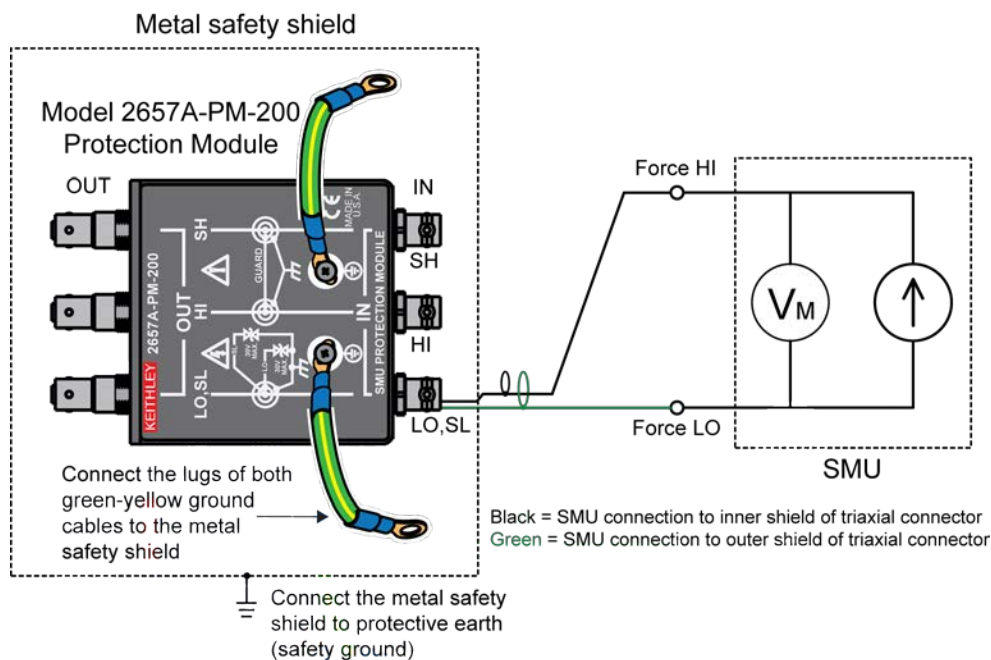

2. Configure the SMU to source current and measure voltage.
3. Program the current source level to 10 mA.
4. Set the voltage limit to 50 V.
5. Turn on the output.
6. Verify that the voltage measured is between 30 V and 40 V.
7. Program the current source level of the SMU to -10 mA.
8. Verify that the voltage measured is between -30 V and -40 V.

Verify voltage protection device between Guard and Force LO

A Keithley SourceMeter® instrument capable of sourcing 20 mA at 300 V is required for verification procedures E and F. The Model 2657A High Power System SourceMeter® Instrument or Model 2410 High Voltage SourceMeter® Instrument is recommended. An oscilloscope capable of measuring up to 300 V is also recommended.

WARNING

A safety shield must be used whenever hazardous voltages (>30 V RMS, 42 V peak) will be present in the test circuit. To prevent electrical shock that could cause injury or death, never use a Keithley SourceMeter® instrument in a test circuit that may contain hazardous voltages without a properly installed and configured safety shield. The following procedures show the use of a metal safety shield. Connect the enclosure of the metal test fixture to protective earth (safety ground).

If using a nonconductive test fixture, it must be rated to double the maximum capability of the test equipment in the system and the two green-yellow ground cables for the Model 2657A-PM-200 must be connected to protective earth (safety ground). Failure to attach the ground wires to a known protective earth may result in electric shock.

Not shown in the simplified block diagram are redundant voltage protection devices between the inner shields (guard) of the HI and SH (sense HI) terminals of the Model 2657A-PM-200. Verification procedures E and F checks both of these devices.

Verification procedure E

Verify proper operation of the protection device between the inner shields of the Sense HI (SH) and LO terminals of the Model 2657A-PM-200:

1. As shown in the connection drawing below, connect the high voltage source-measure unit (HV SMU) to the SH and SL triaxial connectors of the protection module:
 - a. Connect the SMU Force HI terminal to the inner shield of the SH OUT triaxial connector of the Model 2657A-PM-200.
 - b. Connect the SMU Force LO terminal to the inner shield of the SL OUT triaxial connector of the Model 2657A-PM-200.

Figure 13: Connections for verification procedure E

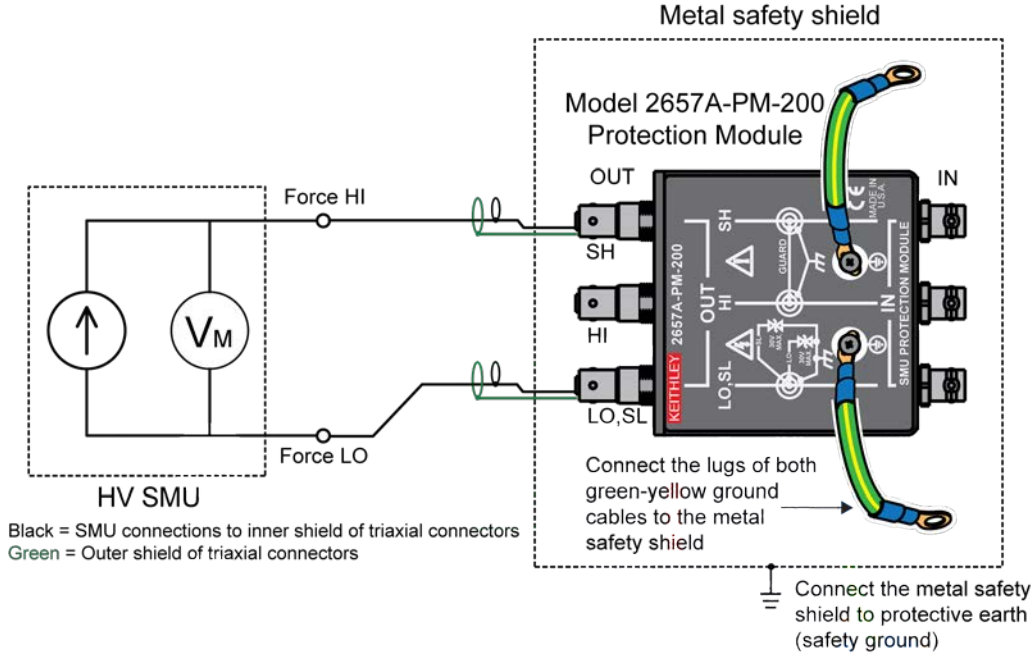

2. Configure the HV SMU to source current and measure voltage.
3. Program the current source level to 20 mA.
4. Program the voltage limit to 220 V.
5. Turn on the HV SMU output.
6. Verify that the voltage measured is 220 V.
7. Program the current source level to -20 mA.
8. Verify that the voltage measured is -220 V.
9. Turn off the HV SMU output.
10. Connect the scope across the output terminals of the HV SMU.
11. Configure the HV SMU to source voltage.
12. Program the voltage source level to +300 V.
13. Turn on the HV SMU output and trigger the scope.
14. Verify that the voltage waveform on the scope has a ramped waveform. The voltage should ramp up to at least 150 V and then clamp to less than 50 V.
15. Turn off the HV SMU output.
16. Program the voltage source level to -300 V.
17. Turn on the HV SMU output.
18. Verify that the voltage waveform on the scope has a ramped waveform. The voltage should ramp down to at least -150 V and then clamp to less than -50 V.

Verification procedure F

Verify proper operation of the protection device between the inner shields of the HI and LO terminals of the Model 2657A-PM-200:

1. As shown in the connection drawing below, connect the high voltage source-measure unit (HV SMU) to the HI and LO,SL triaxial connectors of the protection module:
 - a. Connect the SMU Force HI terminal to the inner shield of the HI OUT triaxial connector of the Model 2657A-PM-200.
 - b. Connect the SMU Force LO terminal to the inner shield of the LO,SL OUT triaxial connector of the Model 2657A-PM-200.

Figure 14: Connections for verification procedure F

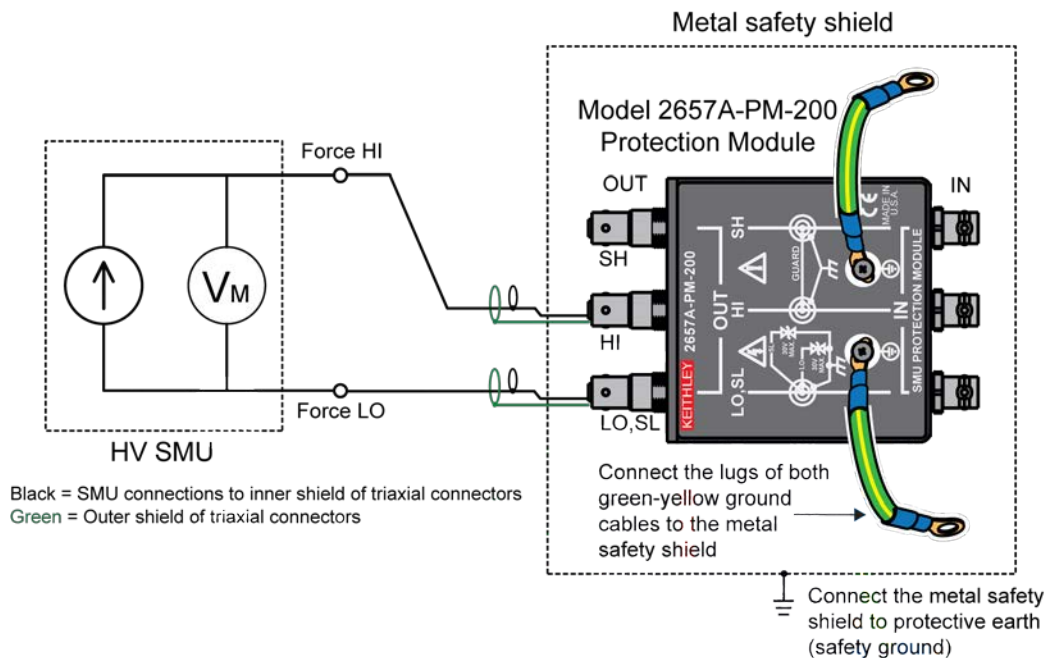

2. Configure the HV SMU to source current and measure voltage.
3. Program the current source level to 20 mA.
4. Program the voltage limit to 220 V.
5. Turn on the HV SMU output.
6. Verify that the voltage measured is 220 V.
7. Program the current source level to -20 mA.
8. Verify that the voltage measured is -220 V.
9. Turn off the HV SMU output.
10. Connect the scope across the output terminals of the HV SMU.
11. Configure the HV SMU to source voltage.
12. Program the voltage source level to +300 V.

13. Turn on the HV SMU output and trigger the scope.
14. Verify that the voltage waveform on the scope has a ramped waveform. The voltage should ramp up to at least 150 V and then clamp to less than 50 V.
15. Turn off the HV SMU output.
16. Program the voltage source level to -300 V.
17. Turn on the HV SMU output.
18. Verify that the voltage waveform on the scope has a ramped waveform. The voltage should ramp down to at least -150 V and then clamp to less than -50 V.