

**7751
7752
7753**

**High Voltage Source/Switch Module
 Low Voltage, Current-Source-Only Source/Switch Module
 1MΩ High Voltage Source/Switch Module**



- Sourcing and switching for airbag inflator testing with the Model 2790
- Programmable 0–50mA current source
- Programmable 50–500V voltage source (7751 and 7753)
- Built-in I/V converter (7751 and 7753)
- Low energy sources, a hardware source interlock, and programmable shunts help prevent accidental detonations

Ordering Information

- 7751** High Voltage Source/Switch Module
- 7752** Low Voltage, Current-Source-Only Source/Switch Module
- 7753** 1MW High Voltage Source/Switch Module

SERVICES AVAILABLE

7751-3Y-EW	1-year factory warranty extended to 3 years from date of shipment
7752-3Y-EW	1-year factory warranty extended to 3 years from date of shipment
7753-3Y-EW	1-year factory warranty extended to 3 years from date of shipment

The Model 7751, 7752, and 7753 Source/Switch Modules are designed exclusively for use in the Model 2790 SourceMeter Switch System for electrical checks of airbag inflators and a variety of other automotive electrical test applications. These modules provide the programmable high voltage and low current sourcing, plus the multichannel switching support required to measure insulation resistance and conductor continuity in these applications.

The Model 7751 and 7753 modules include programmable DC voltage (50–500V) and current (0–50mA) sources, as well as relay switching. A built-in current-to-voltage converter on these modules is used with the voltage source to measure the insulation resistance. They can also be used to measure currents from 0–50μA. The constant current source is useful for measuring the resistance of bridgewires and shunt bars. Four banks of two-pole relays provide a sufficient number of terminals to connect two single inflator units or one dual inflator unit to the Model 2790 mainframe for testing. The mainframe will accommodate two plug-in modules, so a single Model 2790 system can be connected to two test stands and be used to test two dual inflator airbag modules. Parallel testing in the form of “voltage soak with one card, measure with the other” is possible for both single and double test stand configurations. The switch matrix of the Model 7751 and 7753 simplifies implementing contact verification tests and allows the Model 2790 to verify test voltages and currents for increased measurement reliability.

The Model 7752 module is identical to the Model 7751, except that it does not include the high voltage source and current-to-voltage converter. The Model 7753 is identical to the Model 7751 except that the lowest high ohms measurement for the Model 7753 is 1MΩ and for the Model 7751 is 10MΩ.

Safety related design features that provide added protection against accidental detonation include low energy sources, a hardware source interlock, and programmable shunts that can be used in conjunction with an inflator’s shunt bar.

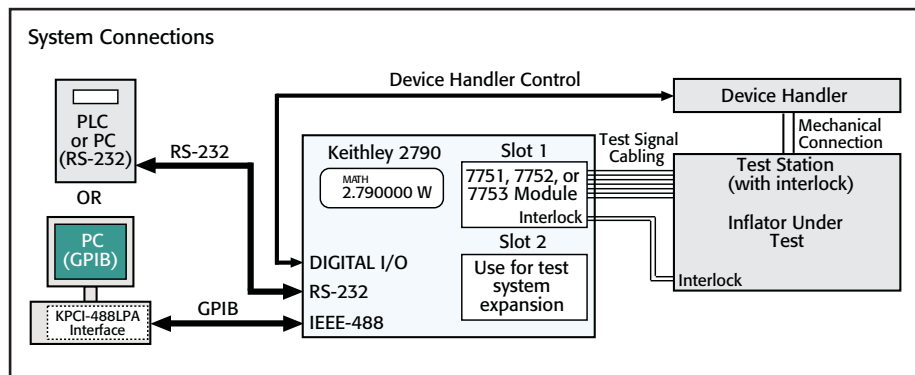

Source/switch modules for airbag inflator testing with the Model 2790

DIGITAL MULTIMETERS & SYSTEMS

1.888.KEITHLEY (U.S. only)
www.keithley.com

KEITHLEY

A GREATER MEASURE OF CONFIDENCE