

CL510 Quick Installation Guide

Lumens™

1. Instruction for Installation

1.1 Preparation before installation

Installation and connection of CL510 ceiling camera requires special skills. To install by yourself, please follow necessary steps, ensure steady and tight installation of the device, and pay attention to your safety to avoid any accident.

- * Ensure the safety of the installation environment. Please do not install the device on unstable ceiling or in a place where the device is in danger of falling to avoid any accident.
- * Please check whether accessories in the box are complete or not. Please contact the supplier for any shortage, and make sure to keep the accessories in the box intact.
- * Please choose a proper place for installation of CL510 in advance. Please determine an installation place according to the following requirements:
 - ▼ Confirm the position for the object to be captured.
 - ▼ Calculate the height required for hanging the device according to the position of the object to be captured.
- * Please prepare the following tools for easy installation and shorter installation time:
 - ▶ Accessories of CL510 in the box.
 - ▶ Hanging parts (ceiling mounted hanger, screw for fixing the hanger 1/4-UNC x 4).
 - ▶ Drilling machine, screw driver.
 - ▶ Ladder.

2. Schematic diagram for the size of U-hanger and preparation before installation

2.1 Schematic diagram for the size of U-hanger

The installation personnel should prepare the screw hanger in compliance with the size of the hole used for securing the hanger. (The screw hanger should be bought separately.)

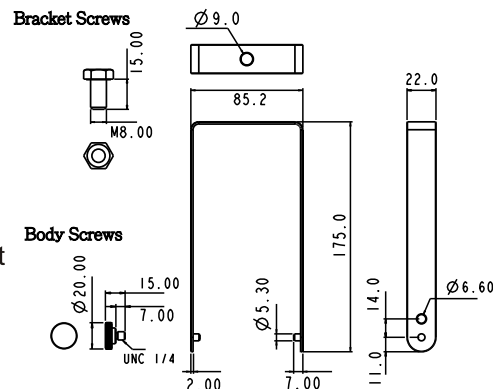

3. I would like to install CL510 on the ceiling

3.1 Installation steps

1. Adjust the DIP SWITCH to the desired output specifications
2. Assemble the U-hanger and the device using screws supplied.
3. Please follow the instruction for the screw hanger to install it on the ceiling.
4. Screw the device onto the screw hanger and complete the installation.

3.2 DIP Switch Setting

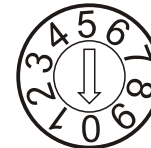

Setting	Output Mode
0	XGA(Default)
1	SXGA
2	WXGA
3	UXGA
4	1080P

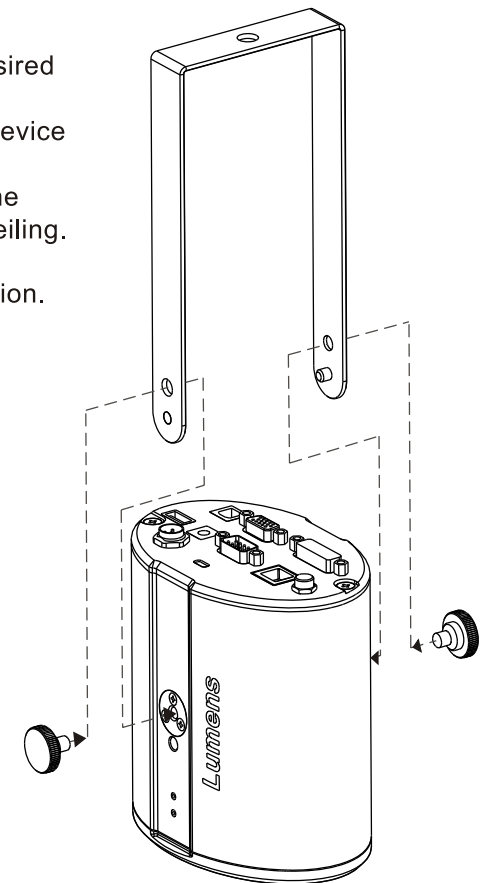

4. Installation and setup before use

1. After the power is on, press [MENU] to enter the menu to adjust the power frequency.
 - * Please refer to [Appendix 1 of CL510 Installation Guide](#) for applicable frequency in various regions.
2. Press [LASER] on the remote control to enable the laser mark, and then press [FREEZE] -> [DEL] -> [◀] to enable the center positioning mark. To be positioned in the center point, use a cross point screw driver to adjust the knob so that the two marks overlap.
3. Open the Service Menu to set up the AF Table.
 - * For more operation instructions, please refer to [CL510 Installation Guide](#).

1. 安装说明

1.1 安装前准备

CL510吸顶摄录展台的安装和连接需要专门的技巧，请用户自行安装时，依照安装程序循序安装，且确认设备之安装稳定牢固，并注意自身安全，避免意外。

- * 确认安装环境的安全性，请勿将机体安装于不可靠之天花板或易于掉落之处，以免发生意外。
- * 请先检查箱内之配件是否齐全，若有缺件，请与供应商联络并告知短缺之配件，且请保持箱体配件之完整。
- * 安装前须事先规划 CL510安装的位置，请依照下列项目规划安装的位置：
 - ▼ 确认取像物件的摆设位置。
 - ▼ 依照取像位置计算出机器需吊挂的高度。
- * 备妥以下安装工具，以利安装方便，缩短安装时间：
 - ▼ CL510箱内之配件。
 - ▼ 吊挂组件(天花板吊架、吊架固定螺丝1/4-UNC*4颗)。
 - ▼ 钻孔机、螺丝起子。
 - ▼ 梯子。

2. U型吊架尺寸示意图与安装前准备

2.1 U型吊架尺寸图

请安装人员依据U型吊架固定孔之尺寸准备螺杆吊架(螺杆吊架请另行购买)

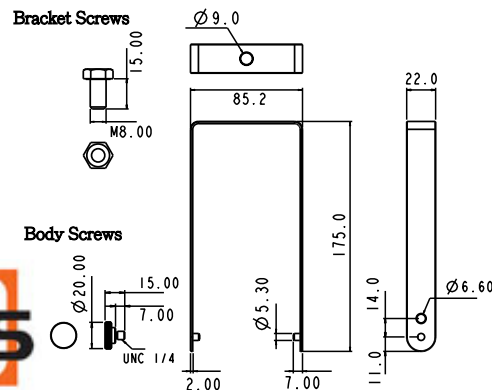

3. 我想要将CL510安装于天花板

3.1 安装步骤

1. 依输出设备规格调整 DIP SWITCH
2. 用配件螺丝组装 U型吊架及展台
3. 请依螺杆吊架说明安装螺杆吊架至天花板
4. 将展台锁固至螺桿吊架即完成安装

3.2 DIP SWITCH设定

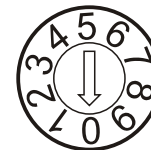

设定(Setting)	输出模式
0	XGA(Default)
1	SXGA
2	WXGA
3	UXGA
4	1080P

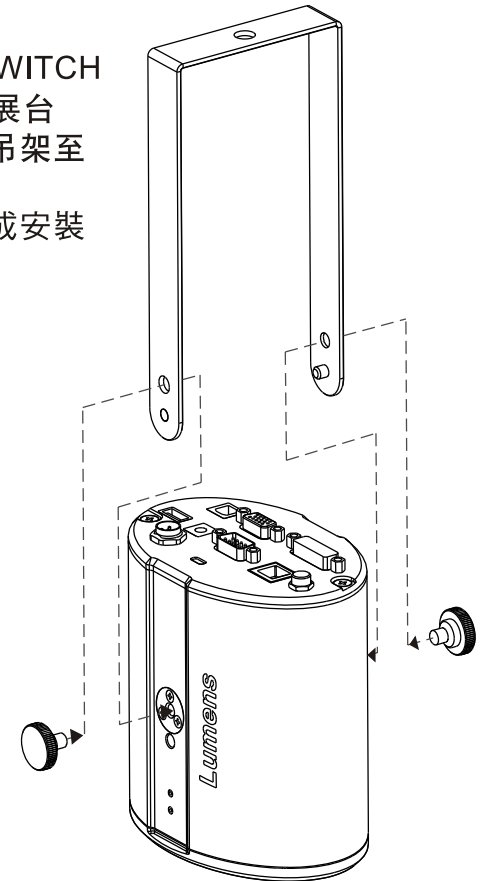

4. 使用前安装设定

1. 开启电源后，按[MENU]进入选单调整电源频率
 - * 各地适用电源频率，请参考CL510安装手册附件一
2. 按下遥控器上[LASER]开启雷射标记，再按下[FREEZE] -> [DEL] -> [◀]开启中心定位标记，使用十字起子调整旋钮，使两标记重合，以定位至中心点
3. 开启 Service Menu 萤幕选单设定 AF Table
 - * 更多操作内容，请参考CL510安装手册