



Single-handed process validation



The accuracy of digital technology combined with the simplicity of an analog gauge.

Specifications (0 °C to +50 °C, unless otherwise noted)

Input Ranges

15 psi/1 BAR, 30 psi/2 BAR, 100 psi/7 BAR,
500 psi/30 BAR, 1,000 psi/70 BAR,
3,000 psi/200 BAR, 5,000 psi/300 BAR,
10,000 psi/700 BAR

Accuracy

±0.05% FS Positive Pressure
±0.25% FS Vacuum/500 psi and below

Temperature Compensation

0 °C to +50 °C (32 °F to +122 °F) to rated accuracy

Standard Engineering Units

PSI, Bar, Kg/cm², inH₂O (4 °C, 20 °C or 60 °F),
ft H₂O (4 °C, 20 °C or 60 °F), cmH₂O (4 °C and
20 °C), mH₂O (4 °C and 20 °C), Kpa, mBAR, inHg,
mmHg, TORR

Media Compatibility

liquids and gases compatible with 316 stainless steel

Environmental

Operating Temperature

-10 °C to +55 °C

Storage

-20 °C to +70 °C (-4 °F to +158 °F)

Mechanical

Dimensions

4.375" x 5.0" x 1.50"

Input Port

1/4" male NPT

Display

5 Digits, 0.65" (16.53 mm) height

Bar Graph – 0 to 100% in 20 segments

Power

Battery

three (3), size AA alkaline batteries

Battery Life

1,500 hours without backlight;

2,000 hours at slow sample rate;

battery life can be displayed on bar graph to

indicate the amount of time left

Low Battery Indicator

displayed icon near the end of battery life

Includes: manual, batteries

Ordering Information

Order Model: BetaGauge - PI - xxx - x - Kitx - RB - 24

15,000 psi/1 BAR; xxx = 015
30,000 psi/2 BAR; xxx = 030
100.00 psi/7 BAR; xxx = 100
500.00 psi/30 BAR; xxx = 500
1,000.00 psi/70 BAR; xxx = 01K
3,000.0 psi/200 BAR; xxx = 03K
5,000.0 psi/300 BAR; xxx = 05K
10,000 psi/700 BAR; xxx = 10K

Port Position

Bottom (standard); x = __ (leave blank)

Back (option); x = B

Kit

With 500 pound pump; Kit5
With 3,000 pound pump; Kit3
(includes BetaGauge P. I., pressure calibration hand pump, and fittings)

Available Options

Rubber Boot; RB

External 24 VDC Power Input; 24

Sanitary Seal

Please obtain seal worksheet/ordering information by calling the factory, or visit <http://www.betalibrators.com>, to download the Sanitary Seal Order Form from the Pressure Products, BetaGauge P. I. section.



BetaGauge P. I. Kit

www.betalibrators.com

BETA Calibrators Corporation
Londonderry, NH; Tel: 800-821-0023
Farmers Branch, Texas; Tel: 800-537-2181

Email: sales@betalibrators.com; Web: www.betalibrators.com

The BetaGauge P. I. — performance, ease-of-use, and an unmatched feature set!

Features:

- Very high accuracy compared to analog test gauges; $\pm 0.05\%$ F. S.; temperature compensated
- Temperature compensated accuracy over 0 to 50 °C
- Eight (8) standard pressure ranges
- Displays in 18 standard or fully custom engineering units
- Displays ambient temperature in °C or °F
- Large, back-lit, 5-1/2 digit display with 0.65" high digits and 20 segment bar graph
- Rugged stainless steel case meets NEMA 4/IP65
- Password-protected "through the keypad" calibration
- MIN/MAX recall
- Adjustable TARE zeros large system offsets
- User-configurable sample rate maximizes measurement performance and battery life
- User-configurable damping smooths readings from pulsating/plant air sources
- Auto Shut-off for extended battery life
- Low battery indicator
- CSA intrinsically safe, Class 1, Div. 1 approvals pending
- CE approved
- Available with optional sanitary seal
- Available with optional 24 V external power input
- Available with optional rubber boot

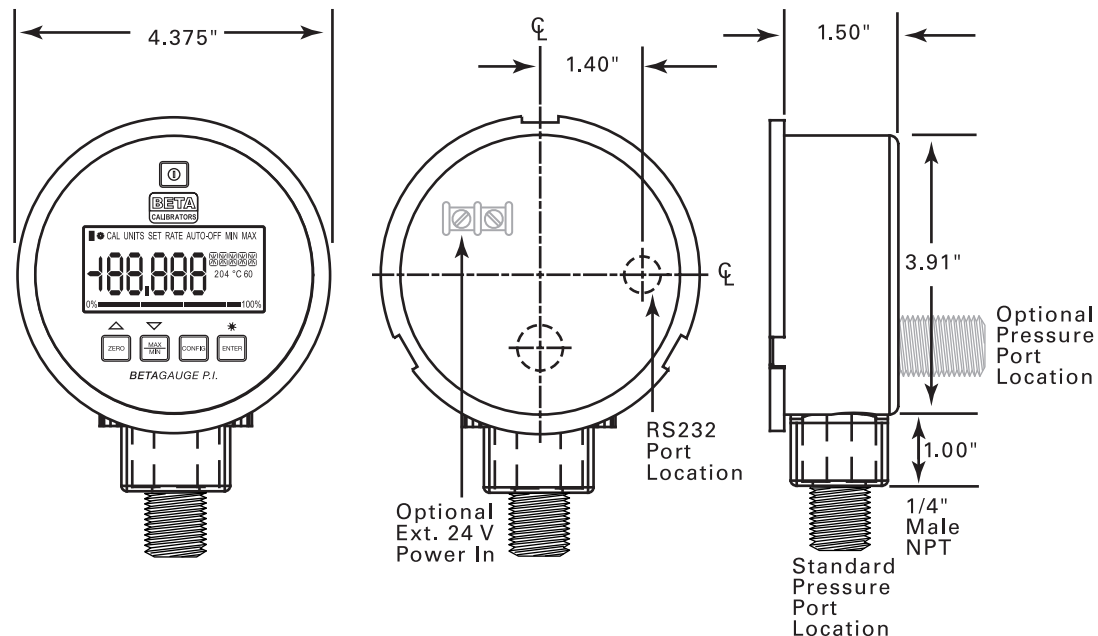

Description:

The BetaGauge P. I. Digital Pressure Test Gauge takes the concept of an analog Test Gauge, and brings it to a new level, as only Beta Calibrators can do. The BetaGauge P. I. combines the accuracy of digital technology with the simplicity of an analog gauge, and achieves performance, ease-of-use, and a feature set unmatched in the pressure measurement world. Setup of the BetaGauge P. I. is fast and straightforward, through a menu-driven display, with minimal text, and intuitive functions, that is simple enough to allow the gauge to be used anywhere in the world, without the need for multilingual displays. And the availability of optional sanitary seals that meet 3A standards per specification 37-01 allow the gauge to be used in virtually any application.

Ease-of-use, performance, and features set the BetaGauge P. I. Digital Pressure Test Gauge apart, just as you've come to expect from Beta Calibrators!

Accuracy

The BetaGauge P. I. first and foremost, provides 0.05% of full scale readings of pressure in any one of eight (8) ranges. Readings may be displayed in any one of 18 standard engineering units, or, in custom units you define, to eliminate tedious conversion calculations.

Display

The 5-1/2 digit, 0.65" high digital display and companion percent-of-range bar graph provide an easy to read display, even from a distance.

Sampling Rate

The reading sample rate can be user-adjusted to match the type of measurement required. For example, when capturing pressure switch threshold points, a 10 samples/second sample rates allows more data points for a more accurate reading of the actual switching threshold. For normal use, a "standard" instrument-grade 3 samples/second rate can be set. In instances where the signal needs to be filtered, the sample rate can be set to 1 sample/second. A power saving mode, at 1 sample per 2 seconds, allows the BetaGauge P. I. to enter a "sleep" mode, where the display is frozen between readings, maximizing battery life to 2,000 hours. This mode is ideal when more frequent readings are not necessary and battery life is a concern, especially in panel-mounted applications.

MIN/MAX Function

A MIN/MAX function is provided which instantly recalls the minimum and maximum pressure readings that have been automatically stored by the BetaGauge P. I.

Auto Shutoff

An auto power shutoff feature may be enabled for a preset time interval to extend battery life.

Field Recalibration

Password-protected field calibration of the BetaGauge P. I. may be initiated through the keypad.

RS232 Port

An RS232 port allows pressure reading data to be extracted directly from the gauge for off-line analysis. Requires Martel RS232 cable (P/N C232S).

TARE

Adjustment In addition to a ZERO function that compensates for sensor drift, large residual system pressures can be nulled using the TARE adjustment. This adjustment, when combined with the ability to create custom engineering units for display, allows the BetaGauge P. I. to be used in a variety of liquid level and volume measurements, easily reading units of interest, such as gallons in a tank, directly.

Temperature Display and Compensation

The BetaGauge P. I. is temperature compensated to retain its accuracy over its operating range. The temperature measured by its internal sensor can be displayed in °C or °F.

Damping Adjustment

Damping can be set to integrate readings to accommodate pulsating sources, such as plant air.

Sanitary Seal Option

The BetaGauge P. I. is available with diaphragm seals made of 316 stainless steel, with quick-couples that meet 3A Standards per specification 37-01 for use in sanitary piping applications in the food, beverage, pharmaceutical, and other industries requiring extreme levels of purity. The seal elements are designed to mount on tees or welding ferrules. Their design allows for fast, efficient installation and removal for flushing or changing process media, line cleanout, and equipment washdown.

External Power Input Option

An optional external 24 VDC power input is available for applications where the BetaGauge P. I. will be permanently incorporated into a process line.

Rubber Boot Option

A protective rubber boot is available to help protect the BetaGauge P. I. from damage when dropped.

Pressure Calibration Kit Option

The BetaGauge P. I. is available in a self-contained calibration kit, including a hand pressure pump, and associated fittings.

