

AWB-S™ RS-232/485 RF Modem

AWB-S RS-232/485 RF Modem

Interfacing Protocols

RF Operation

Advanced Programming

Appendices

Product Manual v1.0.0

1 Watt Transmit Power, -110 dBm Receiver Sensitivity, 256-bit AES Encryption

Adalet Wireless
4801 W. 150th St.
Cleveland, OH 44135
Phone: 216-267-6864
Fax: 216-267-3219

info@adaletwireless.com
www.adaletwireless.com

AWB-S Manual
9/27/2005

© 2005 All rights reserved

No part of the contents of this manual may be transmitted or reproduced in any form or by any means without the written permission of Adalet Wireless.

AES Encryption Source Code

© 2005, Dr Brian Gladman, Worcester, UK. All rights reserved.

Conditions:

- Distributions of AES source code include the above copyright notice, this list of conditions and disclaimer.
- Distributions in binary form include the above copyright notice, this list of conditions and disclaimer in the documentation and/or other associated materials.
- The copyright holder's name is not used to endorse products built using this software without specific written permission.

Alternatively, provided that this notice is retained in full, this product may be distributed under the terms of the GNU General Public License (GPL), in which case the provisions of the GPL apply INSTEAD OF those given above.

Disclaimer - This AES software is provided 'as is' with no explicit or implied warranties in respect of its properties, including, but not limited to, correctness and/or fitness for purpose.

Technical Support:

Phone: 216-267-6864

E-Mail: info@adaletwireless.com

Contents

1. AWB-S RS-232/485 RF Modem	4
Features	4
Worldwide Acceptance	4
Specifications	5
AWB-S Interface	6
2. Interfacing Protocols	7
RS-232 Operation	7
DIP Switch Settings & Pin Signals	7
RS-485 (2-wire) Operation	9
DIP Switch Settings & Pin Signals	9
RS-485 (4-wire) & RS-422 Operation	10
DIP Switch Settings & Pin Signals	10
RS-485/422 Connection Guidelines	11
3. RF Operation	12
Serial Communications	12
RS-232 and RS-485/422 Data Flow	12
Host and RF Modem I/O Settings	12
Flow Control	13
Modes of Operation	14
Idle Mode	14
Transmit Mode	14
Receive Mode	16
Sleep Mode	17
Shutdown Mode	17
Command Mode	18
RF Communication Options	20
Addressing Options	20
Streaming Mode	21
Acknowledged Mode	22
Multi-Transmit Mode	24
4. Advanced Programming	25
Automatic DIP Switch Configurations	25
Programming the AWB-S RF Modem	26
AT Command Examples (AWBridge Software)	26
Binary Command Example	27
Command Descriptions (Short)	28
Command Descriptions (long)	29
Appendix A: Agency Certifications	46
FCC Certification	46
Labeling Requirements	46
FCC Notices	47
FCC-Approved Antennas (900 MHz)	48
IC (Industry Canada) Certification	50
Appendix B: Additional Information	51
1 Year Warranty	51
Contact CoName	51

1. AWB-S RS-232/485 RF Modem

The AWB-S RF Modem (900 MHz) is a drop-in wireless solution that provides long range data communications between RS-232/485 devices. Simply feed serial data into one modem and the data surfaces on the other side of the wireless link.

The modem transfers a standard asynchronous serial data stream between two or more modems. Its built-in RS-232, RS-485 and RS-422 interfacing allows for rapid integration into existing data systems.

Features

Long Range Performance

1 Watt Power Output (1 mW – 1 W, selectable)

Range (@ 9600 bps throughput data rate):

- Indoor/Urban: **up to 3000'** (900 m)
- Outdoor line-of-sight: up to **14 miles** (22 km) w/ dipole antenna
- Outdoor line-of-sight: up to **40 miles** (64 km) w/ high gain antenna

Range (@ 115200 bps throughput data rate):

- Indoor/Urban: **up to 1500'** (450 m)
- Outdoor line-of-sight: up to **7 miles** (11 km) w/ dipole antenna
- Outdoor line-of-sight: up to **20 miles** (32 km) w/ high gain antenna

Receiver Sensitivity: -110 dBm (@ 9600 baud),
-100 dBm (@ 115200 baud)

Advanced Networking & Security

True Peer-to-Peer (no "master" required),
Point-to-Point, Point-to-Multipoint & Multidrop

Retries and Acknowledgements

FHSS (Frequency Hopping Spread Spectrum)

10 hopping channels - each with over 65,000 network addresses available

256-bit AES Encryption (See KY Command [p34] for implementation)

Easy-to-Use

No configuration required

Advanced configurations available
through AT & binary Commands

External DIP Switch configurations

7 to 28 V power supply

Continuous RF data stream of up to
115.2 kbps

Transparent Operation – Wireless links
replace serial wires

Software-selectable serial interfacing

MODBUS, $\overline{\text{CTS}}$, $\overline{\text{RTS}}$, $\overline{\text{DCD}}$ & $\overline{\text{DTR}}$
I/O Support

XII™ Interference Immunity

Power-saving Sleep Modes

Streaming, Acknowledged & Multi-Send
RF Communication Options

Free & Unlimited Technical Support

Worldwide Acceptance

FCC Approved (USA - Go to Appendix A [p46] for FCC Requirements)
Systems that contain AWB-S Modems can inherit FCC Certification

IC Approved (Canada)

ISM (Industrial, Scientific & Medical) **license-free** 902-928 MHz frequency band

Manufactured under ISO 9001:2000 registered standards



Specifications

Table 1.1. AWB-S RF Modem Specifications

AWB-S 900 MHz RF Modem Specifications			
Performance	@ 9600 bps Throughput Data Rate	@ 115200 bps Throughput Data Rate	
Transmit Power Output	1 mW - 1 W (software selectable)	1 mW - 1 W (software selectable)	
Indoor/Urban Range	Up to 3000' (900 m)	Up to 1500' (450 m)	
Outdoor RF line-of-sight Range	Up to 14 miles (22 km) w/ dipole antenna Up to 40 miles (64 km) w/ high-gain antenna	Up to 7 miles (11 km) w/ dipole antenna Up to 20 miles (32 km) w/ high-gain antenna	
Interface Data Rate (selectable using BD Command)	1200 - 230400 bps	1200 - 230400 bps	
RF Data Rate	10000 bps	125000 bps	
Receiver Sensitivity	-110 dBm	-100 dBm	
Power Requirements (refer also to Table 1.2 below)			
Receive Current	110 mA	110 mA	
Idle Currents	16 sec cyclic sleep (SM=8)	20 mA	19 mA
	8 sec cyclic sleep (SM=7)	21 mA	19 mA
	4 sec cyclic sleep (SM=6)	24 mA	20 mA
	2 sec cyclic sleep (SM=5)	30 mA	22 mA
	1 sec cyclic sleep (SM=4)	39 mA	25 mA
Pin Sleep Power Down	17 mA	17 mA	
Serial Port Sleep Power Down	45 mA	45 mA	
General			
Frequency	902-928 MHz ISM Band		
Spread Spectrum	FHSS (Frequency Hopping Spread Spectrum)		
Modulation	FSK (Frequency Shift Keying)		
Encryption	256-bit AES		
Supported Network Topologies	Peer-to-Peer, Point-to-Point, Point-to-Multipoint & Multidrop		
Channel Capacity	10 hop sequences share 50 frequencies		
Physical Properties			
Size	2.75" x 5.50" x 1.124" (7.90 cm x 13.90 cm x 3.80 cm)		
Weight	7.1 oz. (200 g)		
Serial Connector	DB-9		
Operating Temperature	-40 to 85° C (industrial)		
Antenna			
Connector	RPSMA (Reverse-polarity SMA)		
Type	½ wave dipole whip, 6.75" (17.1 cm), 2.1 dBi Gain		
Impedance	50 ohms unbalanced		
Certifications			
FCC Part 15.247	OUR-9XTEND		
Industry Canada (IC)	4214A-9XTEND		

Table 1.2. AWB-S RF Modem Specifications – Relative to user-selected TX Power Output

Power Requirements (TX currents relative to each TX Power Output option)					
Transmit Power Output	1 mW	10 mW	100 mW	500 mW	1 W
Transmit Current @9600 baud (9 VDC supply voltage, typical)	110 mA	145 mA	250 mA	510 mA	900 mA
Transmit Current @115K baud (9 VDC supply voltage, typical)	110 mA	140 mA	245 mA	500 mA	800 mA

AWB-S Interface

Figure 1.1. Front View

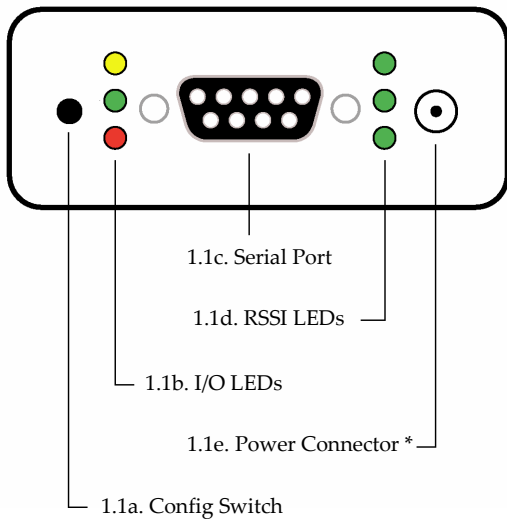

* **Note:** The AWB-S RF Modem can accept voltages as low as 5 (±5%) V.

Contact Adalet Wireless technical support (216-267-6864) to implement this option.

1.1a. Config (Configuration) Switch

The Configuration Switch provides an alternate method for entering into Command Mode. To enter Command Mode at the default RF data rate of the RF modem, depress the Config Switch for two seconds.

1.1b. I/O LEDs

LEDs indicate modem activity as follows:

- Yellow** (top LED) = Serial Data Out (to host)
- Green** (middle) = Serial Data In (from host)
- Red** (bottom) = Power/TX Indicator (Red light is on when powered, pulses off briefly during RF transmission)

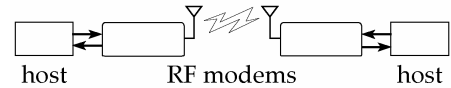

1.1c. Serial Port (DB-9)

Standard female DB-9 (RS-232) DCE connector – Connector can be also used for RS-485 and RS-422 connections.

1.1d. RSSI LEDs

RSSI LEDs indicate the amount of fade margin present in an active wireless link. Fade margin is the difference between the incoming signal strength and the modem's receiver sensitivity.

- 3 LEDs on** = Very Strong Signal (> 30 dB fade margin)
- 2 LEDs on** = Strong Signal (> 20 dB fade margin)
- 1 LED on** = Moderate Signal (> 10 dB fade margin)
- 0 LED on** = Weak Signal (< 10 dB fade margin)

1.1e. Power Connector *

7-28 VDC Power Connector (Center positive, 5.5/2.1mm)

1.2a. DIP Switch

During the power-on sequence, the DIP Switch automatically configures the AWB-S Modem to operate in different modes. Each time the RF modem is powered-on, intelligence inside the AWB-S RF Modem programs the modem according to the positions of the DIP Switch. [Refer to Figure 1.3 for DIP Switch settings]

Refer to Automatic DIP Switch Configurations [p25] for more info.

1.2b. Antenna Port

Port is a 50Ω RF signal connector for connecting to an external antenna. The connector type is RPSMA (Reverse Polarity SMA) female. The connector has threads on the outside of a barrel and a male center conductor.

Figure 1.2. Back View

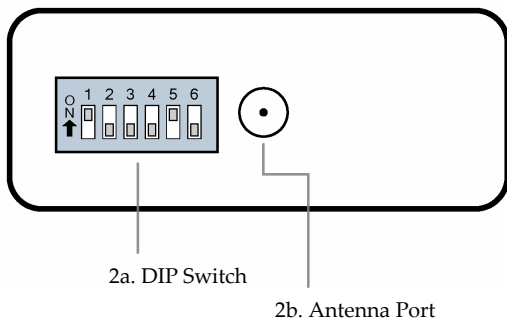
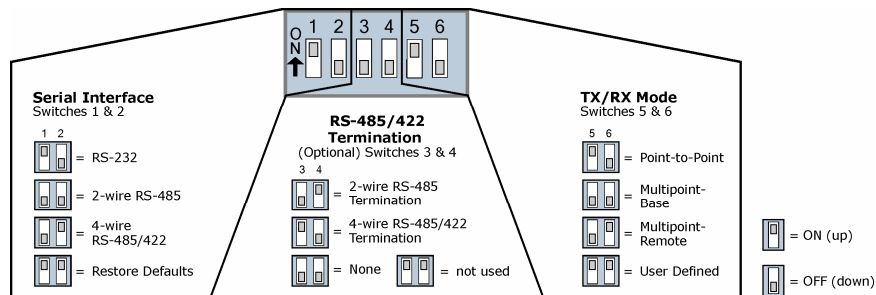

Figure 1.3. DIP Switch Settings



2. Interfacing Protocols

The AWB-S RF Modem supports the following interfacing protocols:

- RS-232
- RS-485 (2-wire) Half-Duplex
- RS-485 (4-wire) and RS-422

RS-232 Operation

DIP Switch Settings & Pin Signals

Figure 2.1. RS-232 DIP Switch Settings

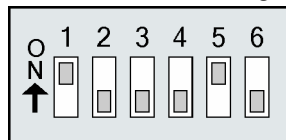

DIP Switch settings are read and applied only while powering-on.

Figure 2.2. Pins used on the female RS-232 (DB-9) Serial Connector

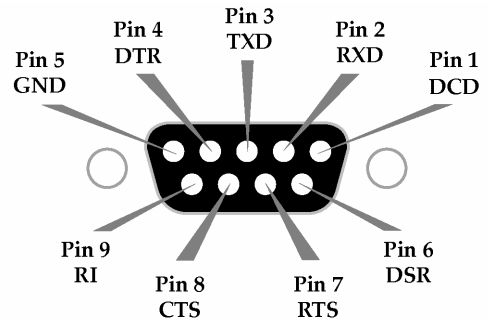

Table 2.1. RS-232 Signals and their implementations on the AWB-S RF Modem
(Low-asserted signals are distinguished by horizontal line over pin name.)

DB-9 Pin	RS-232 Name	Module Name*	Description	Implementation
1	DCD	GPO2 / RX LED	Data-Carrier-Detect	Connected to DSR (pin6)
2	RXD	DO	Received Data	Serial data exiting the RF Modem (to host)
3	TXD	DI	Transmitted Data	Serial data entering into the RF modem (from host)
4	DTR	GPI2 / SLEEP	Data-Terminal-Ready	Can enable POWER-DOWN on the RF Modem
5	GND	-	Ground Signal	Ground
6	DSR	GPO2 / RX LED	Data-Set-Ready	Connected to DCD (pin1)
7	$\overline{\text{RTS}}$ / CMD	GPI1 / $\overline{\text{RTS}}$ / CMD	Request-to-Send	Provides $\overline{\text{RTS}}$ flow control or enables "Command Mode" on the RF Modem
8	$\overline{\text{CTS}}$	GPO1 / $\overline{\text{CTS}}$ / RS-485 TX EN	Clear-to-Send	Provides $\overline{\text{CTS}}$ flow control
9	RI	-	Ring Indicator	Optional power input that is connected internally to the positive lead of the front power connector

* Inside the AWB-S RF Modem is an OEM RF Module. The names in this column refer to the pin signals of the embedded module. AWB-S Commands [p28] used to configure pin behaviors are named according to the pins of the module, not the RS-232 connection.

Wiring Diagram: RS-232 DTE Device to a DCE RF Modem

Figure 2.3. RS-232 DTE (male connector) device wired to an AWB-S RF Modem (female connector)

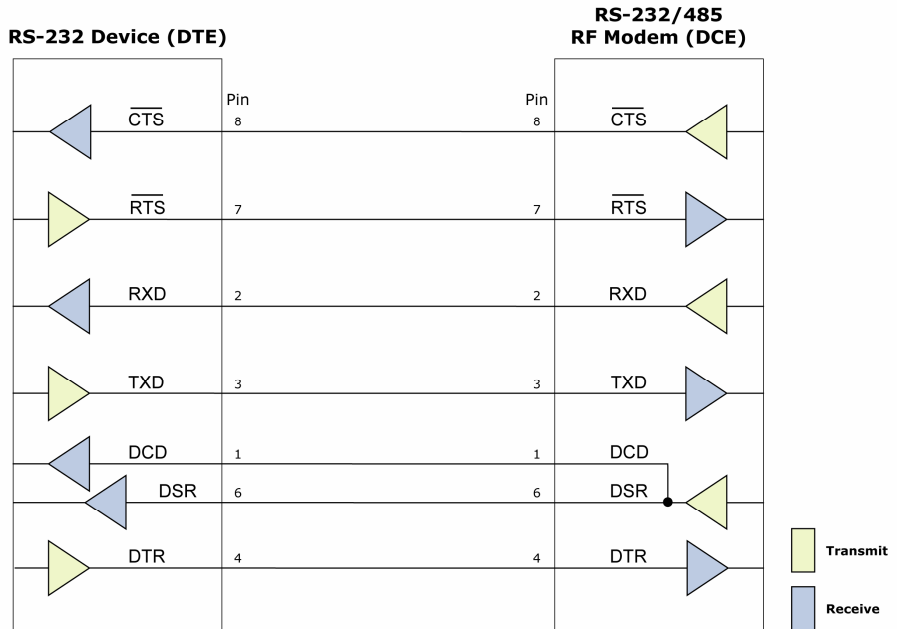

Wiring Diagram: DCE RF Modem to an RS-232 DCE Device

Figure 2.4. AWB-S RF Modem (female connector) wired to an RS-232 DTE (male connector) device

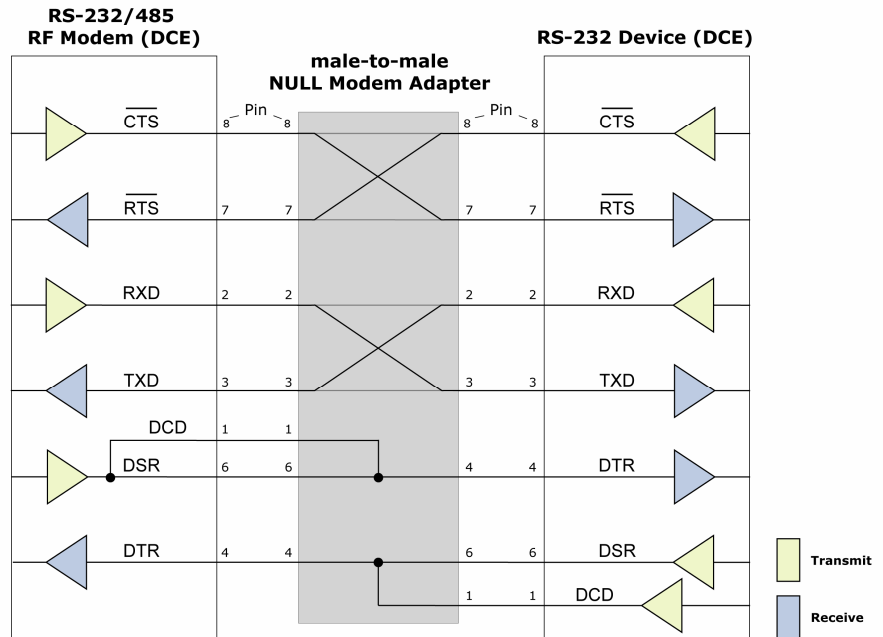

Sample Wireless Connection: DTE ↔ DCE ⚡ DCE ↔ DCE

Figure 2.5. Typical wireless connection used for serial communications between DTE and DCE devices



RS-485 (2-wire) Operation

DIP Switch Settings & Pin Signals

Figure 2.6.
RS-485 (2-wire) Half-Duplex
DIP Switch Settings

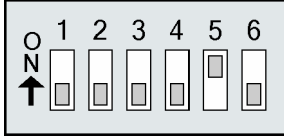
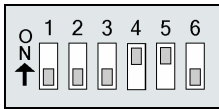

Figure 2.8.
RS-485 (2-wire) with Termination (optional)



Termination is the 120 Ω resistor between T+ and T-.

DIP Switch settings are read and applied only while powering-on.

Figure 2.7.
Pins used on the female RS-232 (DB-9)
Serial Connector

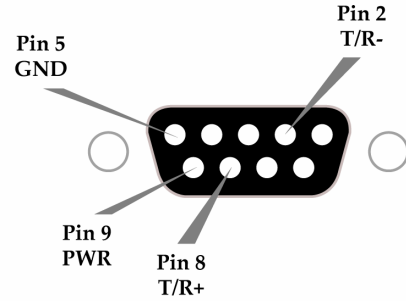

Note: Refer to Figures 2.15 and 2.16 for RJ-45 connector pin designations used in RS-485/422 environments.

Table 2.2. RS-485 (2-wire half-duplex) Signals and their implementations on the AWB-S RF Modem

DB-9 Pin	RS-485 Name	Description	Implementation
2	T/R- (TRA)	Negative Data Line	Transmit serial data to and from the AWB-S RF Modem
5	GND	Ground Signal	Ground
8	T/R+ (TRB)	Positive Data Line	Transmit serial data to and from the AWB-S RF Modem
9	PWR	Power	Optional power input that is connected internally to the front power connector
1, 3, 4, 6, 7			not used

Wiring Diagram: RS-485 (2-wire) Half-Duplex

Figure 2.9. AWB-S RF Modem in an RS-485 (2-wire) half-duplex environment

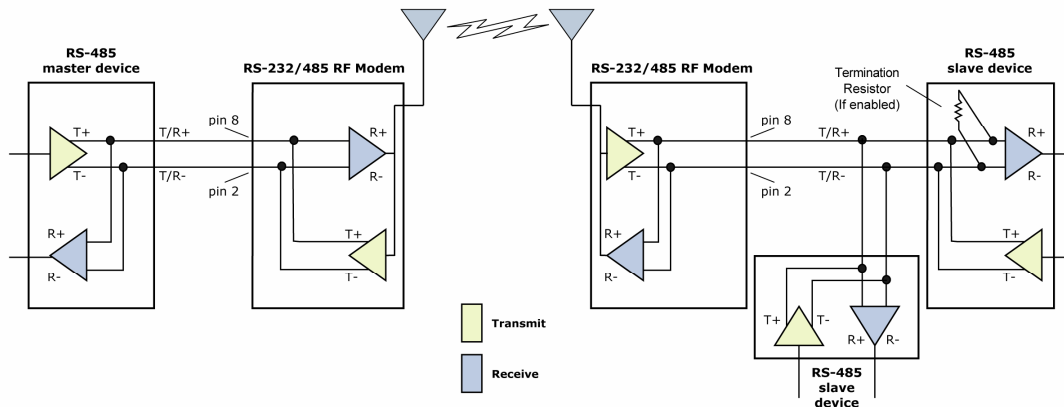

RS-485 (4-wire) & RS-422 Operation

DIP Switch Settings & Pin Signals

Figure 2.10.
RS-485 (4-wire) and RS-422
DIP Switch Settings

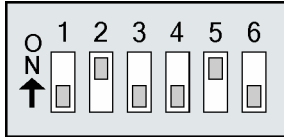
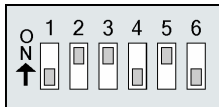

Figure 2.12.
RS-485 (4-wire) & RS-422 with Termination (optional)



Termination is the 120 Ω resistor between T+ and T-.

DIP Switch settings are read and applied only while powering-on.

Figure 2.11.
Pins used on the female RS-232 (DB-9)
Serial Connector

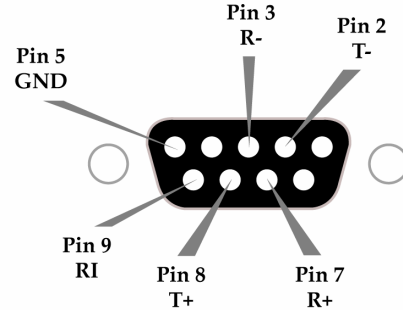
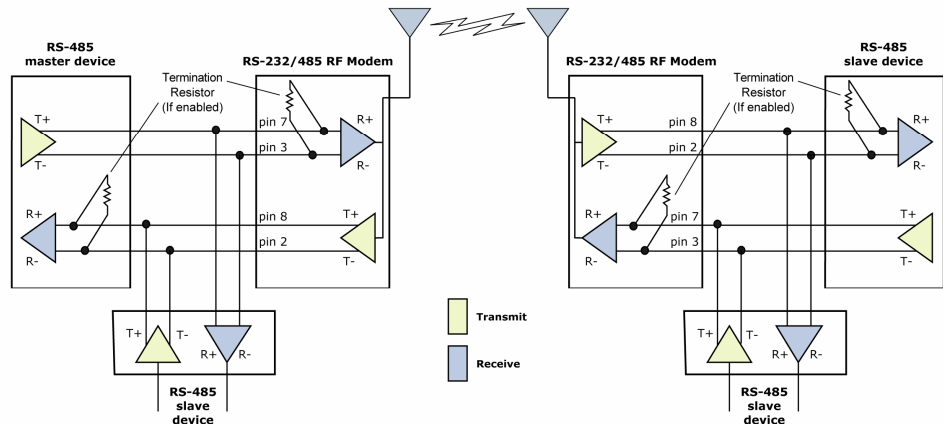

Table 2.3. RS-485/422 (4-wire) Signals and their implementations with the AWB-S RF Modem

DB-9 Pin	RS-485/422 Name	Description	Implementation
2	T- (TA)	Transmit Negative Data Line	Serial data sent from the AWB-S RF Modem
3	R- (RA)	Receive Negative Data Line	Serial data received by the AWB-S RF Modem
5	GND	Signal Ground	Ground
7	R+ (RB)	Receive Positive Data Line	Serial data received by the AWB-S RF Modem
8	T+ (TB)	Transmit Positive Data Line	Serial data sent from the AWB-S RF Modem
9	PWR	Power	Optional power input that is connected internally to the front power connector
1, 4, 6			not used

Wiring Diagram: RS-485 (4-wire) Half-Duplex

Figure 2.13. AWB-S RF Modem in an RS-485 (4-wire) environment



Wiring Diagram: RS-422

Figure 2.14. AWB-S RF Modem in an RS-485 (4-wire) environment

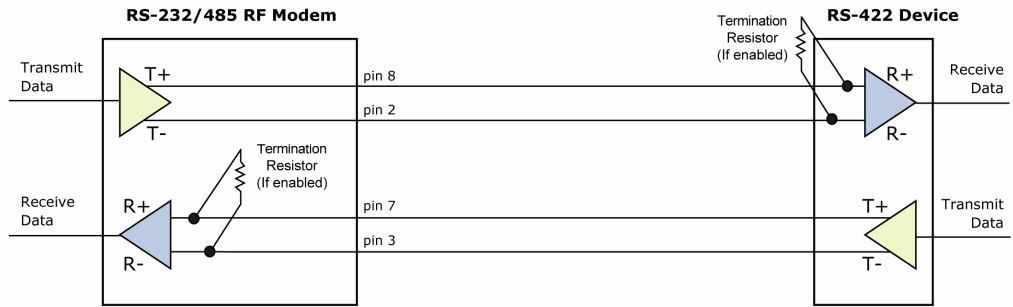

RS-485/422 Connection Guidelines

The RS-485/422 protocol provides a solution for wired communications that can tolerate high noise and push signals over long cable lengths. RS-485/422 signals can communicate as far as 4000 feet (1200 m). RS-232 signals are suitable for cable distances up to 100 feet (30.5 m).

RS-485 offers multi-drop capability in which up to 32 nodes can be connected. The RS-422 protocol is used for point-to-point communications.

Suggestions for integrating the AWB-S Modem with the RS-485/422 protocol:

1. When using Ethernet twisted pair cabling: Select wires so that T+ and T- are connected to each wire in a twisted pair. Likewise, select wires so that R+ and R- are connected to a twisted pair. (For example, tie the green and white/green wires to T+ and T-.)
2. For straight-through Ethernet cable (not cross-over cable) – The following wiring pattern works well: Pin3 to T+, Pin4 to R+, Pin5 to R-, Pin6 to T-
3. Note that the connecting cable only requires 4 wires (even though there are 8 wires).
4. When using phone cabling (RJ-11) – Pin2 in the cable maps to Pin3 on opposite end of cable and Pin1 maps to Pin4 respectively.

Figure 2.15. Male DB-9 to RJ-45 Adapter (yellow)

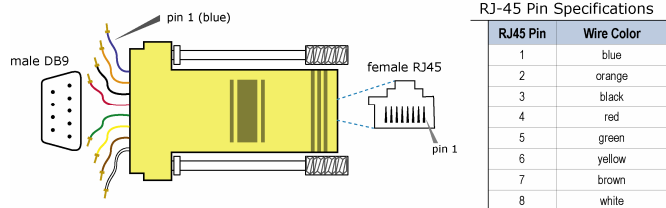
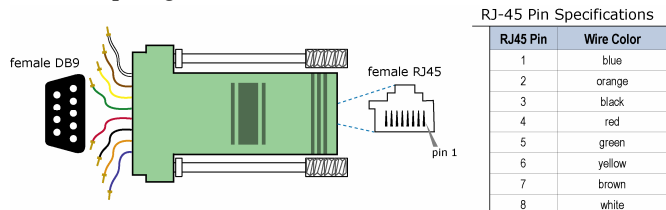

Figure 2.16. Female DB-9 to RJ-45 Adapter (green)



3. RF Operation

⚠ WARNING: When operating at 1 Watt power output, observe a minimum separation distance of 2' (0.6 m) between modems. Transmitting in close proximity of other modems can damage modem front ends.

Serial Communications

RS-232 and RS-485/422 Data Flow

The AWB-S RF Modem interfaces to a host device through a standard RS-232 (DB-9) connector. Devices that have a standard RS-232 serial port can connect directly through the pins of the AWB-S RF Modem as shown in the figure below.

Figure 3.1. System Data Flow in an RS-232 environment

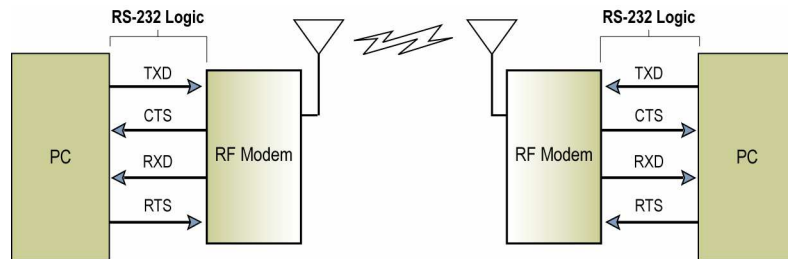

Host and RF Modem I/O Settings

Serial communications between a host and the AWB-S RF Modem are dependent upon having matching baud rate, parity, stop bit & number of data bits settings. Refer to the table below to ensure host serial port settings match those of the AWB-S RF Modem.

Table 3.1. Parameter values critical to serial communications between the RF Modem and host

Parameter Setting	AWB-S RF Modem Default Parameter Value
Baud (Serial Data Rate)	9600 bps (BR parameter = 3)
Number of Data Bits	8 (NB parameter = 0)
Parity	None (NB parameter = 0)
Number of Stop Bits	1 (NB parameter = 0)

Both the AWB-S RF Modem and host (PC) settings can be viewed and adjusted using Adalet Wireless's proprietary AWBridge Software. Use the "Terminal" or "Modem Configuration" tabs to configure the RF Modem settings. Use the "PC Settings" tab to configure host settings. Refer to the Advanced Programming and AWBridge Software sections for more information.

Flow Control

Figure 3.2. Internal Data Flow Diagram

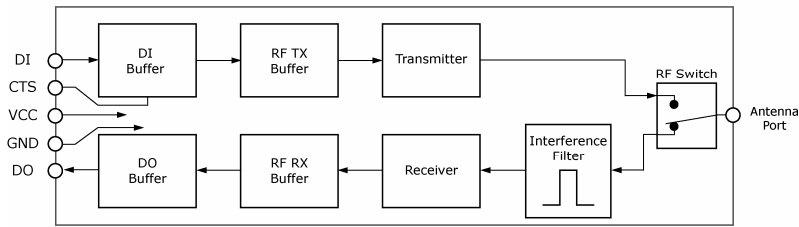

DI (Data In) Buffer and Flow Control

When serial data enters the AWB-S Modem through the DI Pin, the data is stored in the DI Buffer until it can be transmitted.

When the RB and RO parameter thresholds are satisfied (refer to Transmit Mode section [p14] for more information), the modem attempts to initialize an RF connection. If the modem is already receiving RF data, the serial data is stored in the modem's DI Buffer. The DI buffer stores at least 2.1 KB. If the DI buffer becomes full, hardware or software flow control must be implemented in order to prevent overflow (loss of data between the host and AWB-S Modem).

How to eliminate the need for flow control:

1. Send messages that are smaller than the DI buffer size. The size of the DI buffer varies according to the packet size (PK parameter) and the parity setting (NB parameter) used.
2. Interface at a lower baud rate (BD parameter) than the RF data rate (BR parameter).

Two cases in which the DI Buffer may become full and possibly overflow:

1. If the serial interface data rate is set higher than the RF data rate of the modem, the modem will receive data from the host faster than it can transmit the data over-the-air.
2. If the modem is receiving a continuous stream of RF data or if the modem is monitoring data on a network, any serial data that arrives on the DI pin is placed in the DI Buffer. The data in the DI buffer will be transmitted over-the-air when the modem no longer detects RF data in the network.

Hardware Flow Control (CTS). When the DI buffer is 17 bytes away from being full; by default, the modem de-asserts (high) $\overline{\text{CTS}}$ to signal to the host device to stop sending data [refer to FT (Flow Control Threshold, p33) and CS (GPO1 Configuration, p31) Commands.]. $\overline{\text{CTS}}$ is re-asserted after the DI Buffer has 34 bytes of memory available.

Software Flow Control (XON). XON/XOFF software flow control can be enabled using the FL (Software Flow Control) Command [p32]. This option only works with ASCII data.

DO (Data Out) Buffer & Flow Control

When RF data is received, the data enters the DO buffer and is sent out the serial port to a host device. Once the DO Buffer reaches capacity, any additional incoming RF data is lost. The DO buffer stores at least 2.1 KB.

Two cases in which the DO Buffer may become full and possibly overflow:

1. If the RF data rate is set higher than the interface data rate of the modem, the modem will receive data from the transmitting modem faster than it can send the data to the host.
2. If the host does not allow the modem to transmit data out from the DO buffer because of being held off by hardware or software flow control.

Hardware Flow Control (RTS). If $\overline{\text{RTS}}$ is enabled for flow control (RT Parameter = 2, p40), data will not be sent out the DO Buffer as long as $\overline{\text{RTS}}$ is de-asserted.

Software Flow Control (XOFF). XON/XOFF software flow control can be enabled using the FL (Software Flow Control) Command [p32]. This option only works with ASCII data.

Modes of Operation

AWB-S RF Modems operate in five modes.

Figure 3.3. Modes of Operation

The RF modem can only be in one mode at a time.

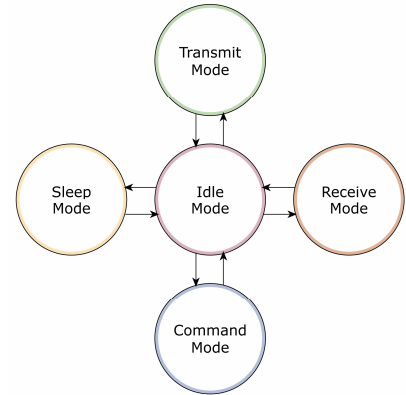

Idle Mode

When not receiving or transmitting data, the modem is in Idle Mode. The modem uses the same amount of power in Idle Mode as it does in Receive Mode.

The modem shifts into the other modes of operation under the following conditions:

- Serial data is received in the DI Buffer (Transmit Mode)
- Valid RF data is received through the antenna (Receive Mode)
- Command Mode Sequence is issued (Command Mode)
- Sleep Mode condition is met (Sleep Mode)

The modem automatically transitions to Idle Mode after finished responding to these conditions.

Transmit Mode

When the first byte of serial data is received from the host in the DI buffer, the modem attempts to shift to Transmit Mode and initiate an RF connection with other modems. After transmission is finished, the modem returns to Idle Mode.

RF transmission begins after either of the following criteria is met:

1. RB bytes have been received by the host and are pending for RF transmission.
[RB (Packetization Threshold) Command]
2. At least one character has been received by the host and is pending for RF transmission, and RO character times of silence have been observed on the host.
[RO (Packetization Timeout) Command]

Figure 3.4. Transmit Mode Data Flow

The character timeout trigger can be disabled by setting RO to zero. In this case, transmission will not begin until RB bytes have been received and are pending for RF transmission. The RB parameter may be set to any value between 1 and the RF packet size (PK), inclusive. Note that transition to Transmit Mode cannot take place during RF reception; the RF reception must complete before the modem can transition into Transmit Mode.

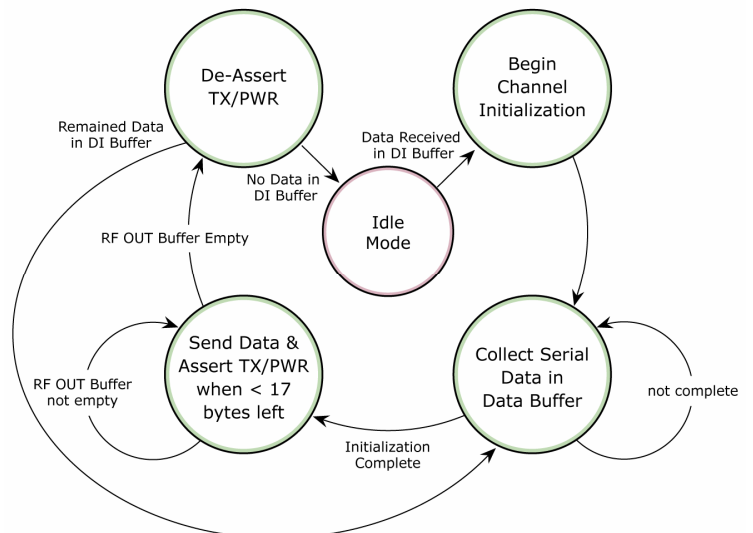

After either of the RB and RO conditions are met, the modem then initializes a communications channel. Serial data in the DI buffer is grouped into RF packets (up to 2048 bytes in each packet - refer to PK (Maximum RF Packet Size) Command), converted to RF data and then is transmitted over-the-air until the DI buffer is empty.

Channel initialization is the process of sending an RF initializer that synchronizes receiving modems with the transmitting modem. During channel initialization, incoming serial data accumulates in the DI buffer.

RF data, which includes the payload data, follows the RF initializer. The payload includes up to the maximum packet size (PK Command) bytes. As the TX modem nears the end of the transmission, it inspects the DI buffer to see if more data exists to be transmitted. This could be the case if more than PK bytes were originally pending in the DI buffer or if more bytes arrived from the host during transmission. If more data is pending, the transmitting modem instructs all listening modems that a subsequent packet is coming. Receiving modems move to the new frequency and listen for the subsequent packet.

Refer to the RF Communication Options [p20] section for information and state diagrams that illustrate channel initialization and the sequence of events that follow.

RF Packet

Figure 3.5. RF Packet Components

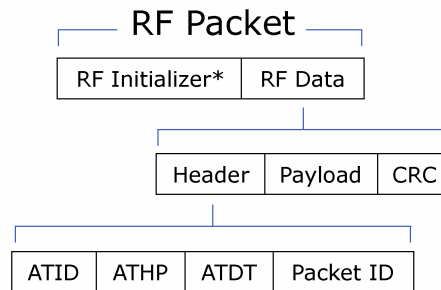

* When streaming multiple RF packets, the RF Initializer is only sent in front of the first packet.

RF Initializer

An RF initializer is sent each time a new connection sequence begins. The RF initializer contains channel information that notifies receiving modems of information such as the hopping pattern used by the transmitting modem. Channel initialization takes 5 ms at the 115k RF data rate and 54 ms at the 9600 RF data rate. The first transmission always sends an RF initializer.

An RF initializer can be of various lengths depending on the amount of time determined to be required to prepare a receiving modem. For example, a wake-up initializer is a type of RF initializer used to wake remote modems from Sleep Mode (Refer to the FH, LH, HT and SM Commands for more information). The length of the wake-up initializer should be longer than the length of time remote modems are in cyclic sleep.

Header

The header contains network addressing information that filters incoming RF data. The receiving modem checks for matching a VID, Hopping Channel and Destination Address. Data that does not pass through all three network security layers is discarded.

Figure 3.6. Network Layers Contained in the Header

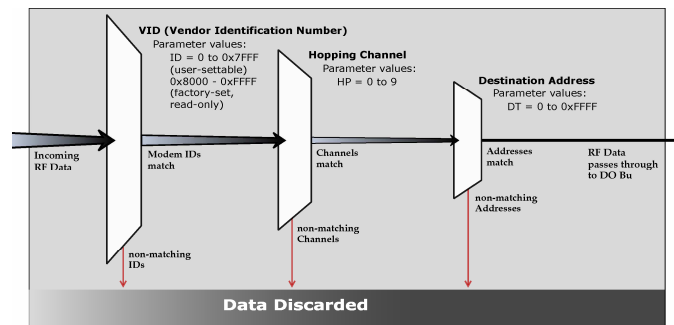

CRC (Cyclic Redundancy Check)

To verify data integrity and provide built-in error checking, a 16-bit CRC (Cyclic Redundancy Check) is computed for the transmitted data and attached to the end of each RF packet before transmission. On the receiving end, the receiving modem computes the CRC on all incoming RF data. Received data that has an invalid CRC is discarded [See Receive Mode section, next page].

Receive Mode

If a modem detects RF data while in Idle Mode, the modem transitions into Receive Mode to start receiving RF packets. Once a packet is received, it goes through the receiving end of a CRC (cyclic redundancy check) to ensure that the data was transmitted without error. If the CRC data bits on the incoming packet are invalid, the packet is discarded. If the CRC is valid, the packet is placed the DO Buffer.

Figure 3.7. Receive Mode Data Flow

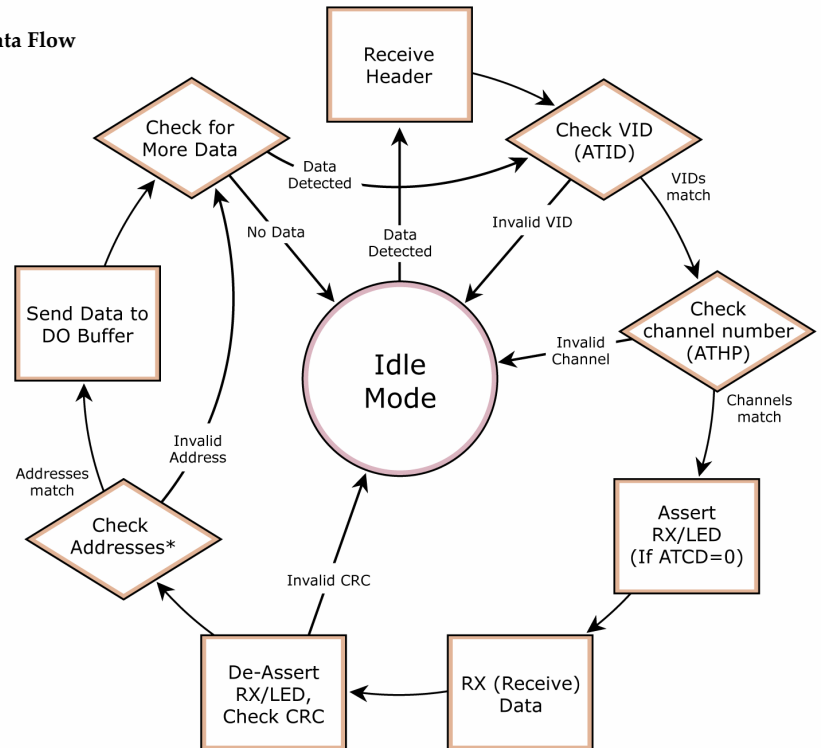

* Refer to the Addressing Options section (under the RF Communication Options chapter) for more information about address recognition.

The modem returns to Idle Mode after valid RF data is no longer detected or after an error is detected within the received RF data. If serial data is stored in the DI buffer while the modem is in Receive Mode, the serial data will be transmitted after the modem is finished receiving data and returns to Idle Mode.

Sleep Mode

Software Sleep

Sleep Modes enable the AWB-S Modem to operate at minimal power consumption when not in use. Three Sleep Mode options are available:

- Host Controlled (Pin Sleep)
- Wake on Serial Port activity (Serial Port Sleep)
- Wake on RF activity (Cyclic Sleep)

For the modem to transition into Sleep Mode, SM (Sleep Mode) Parameter must have a non-zero value and one of the following must occur:

1. The modem is idle (no data transmission or reception) for a user-defined period of time [See ST (Time before Sleep) Command]
[OR]
2. GPI2 pin is asserted [GPI2 is equivalent to DTR (Data-Terminal-Ready) under RS-232 operation. Refer to the RS-232 Operation [p7] section for more information.]

While in Sleep Mode, the modem will not transmit or receive data until the modem first shifts back to Idle Mode. The return to Idle Mode is triggered by the de-assertion of GPI2 or the arrival of a serial byte through the DI pin. Sleep Mode is enabled and disabled using SM Command.

Table 3.2. Summary of Sleep Mode Configurations

Sleep Mode Setting	Transition into Sleep Mode	Transition out of Sleep Mode	Related Commands	Power Consumption
Pin Sleep (SM=1)	Host can shut down and wake modems. Assert GPI2 (SLEEP) pin.	De-Assert GPI2 (SLEEP) pin.	SM	Typically 17 mA
Serial Port Sleep (SM=2)	Automatic transition into Sleep Mode after user-defined period of inactivity (no transmitting or receiving). Period of inactivity set using ST Command.	When serial byte is received on the DI pin.	SM, ST	Typically 45 mA
Cyclic Sleep (SM=4-8)	Transitions into and out of Sleep Mode in cycles (user-selectable wake-up interval of time set by SM Command). The Cyclic Sleep interval time must be shorter than "Wake-up Initializer Timer" (set by LH Command). (Can be forced into Idle Mode using GPI2 (SLEEP) pin if PW (Pin Wake-up) Command is issued.)		HT, LH, PW, SM, ST	Typically 25 mA (when sleeping, SM=4, 1 sec. @120K baud)

For more information about Sleep Modes, refer to the individual commands listed in "Related Commands" column of the table. SM Command is the best starting point.

Shutdown Mode

Hardware Sleep

Shutdown Mode offers the lowest power mode available to Adalet Wireless modem users (< 1 μ A). This mode is not supported by the stand-alone AWB-S RF Modem, but is available through the OEM RF Module that is mounted inside the stand-alone AWB-S RF Modem.

Contact Adalet Wireless Technical Support for more information.

Command Mode

To set or read modem parameters; the modem must first enter Command Mode (a state in which incoming characters are interpreted as commands). Two command types are available:

- AT Commands
- Binary Commands

For modified parameter values to persist in the modem's registry, changes must be saved to non-volatile memory using WR (Write) Command. Otherwise, parameters are reset to previously stored values after the modem is powered off and then on again.

AT Commands

To enter AT Command Mode:

1. Send the 3-character command sequence “+++” and observe guard times before and after the command characters. [See “Default AT Command Mode Sequence” below.]
Use the “Terminal” tab (or other serial communications software) of the AWBridge Software to enter the sequence.
[OR]
2. Force entrance into AT Command Mode by keeping the configuration switch [Figure 1.1a, p7] pressed while turning off, then on again the power supplying the RF modem.

Default AT Command Mode Sequence:

- No characters sent for one second [see BT (Guard Time Before) Command]
- Input three plus characters (“+++”) within one second [see CC (Command Sequence Character) Command.]
- No characters sent for one second [see AT (Guard Time After) Command.]

To Send AT Commands to the RF Modem:

Figure 3.8. Syntax for sending AWB-S AT Commands

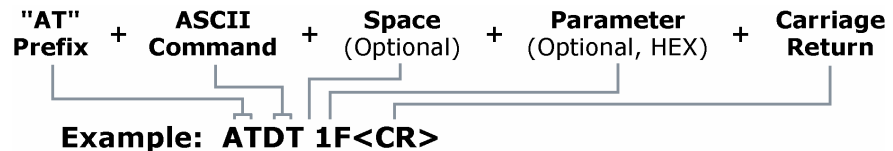

NOTE: To read a current parameter value stored in a register, leave the parameter field blank.

The preceding example would change the modem Destination Address “1F”. To store the new value to the modem's non-volatile (long term) memory, use the WR (Write) Command.

The “Modem Configuration” tab of the AWBridge Software [p26] provides a software user interface that facilitates the programming of RF modems. A more in depth look at modem programming is in the Programming the AWB-S RF Modem section [p26].

To Exit Command Mode:

1. If no valid AT Commands are received within the time specified by CT (Command Mode Timeout) Command, the modem automatically returns to Idle Mode.
[OR]
2. Send ATCN (Exit Command Mode) Command.

For an example on that illustrates programming the modem using AT Commands, refer to the “Terminal tab” section on p26.

Binary Commands

Sending and receiving parameter values using binary commands is the fastest way to change the operating parameters of the XTend RF Modem. Binary commands are used most often to sample signal strength (DB parameter) and/or error counts; or change modem addresses and channels for polling data systems. Since the sending and receiving of parameter values takes place through the same serial data path as 'live' data (received RF payload), interference between the two data types can be a concern.

Common questions about using binary commands:

- What are the implications of asserting CMD while live data is being sent or received?
- After sending serial data, is there a minimum time delay before CMD can be asserted?
- Is a delay required after CMD is de-asserted before payload data can be sent?
- How does one discern between live data and data received in response to a command?.

The CMD pin must be asserted in order to send binary commands to the RF modem. The CMD pin can be asserted to recognize binary commands anytime during the transmission or reception of data. The status of the CMD signal is only checked at the end of the stop bit as the byte is shifted into the serial port. The application does not allow control over when data is received, except by waiting for dead time between bursts of communication.

If the command is sent in the middle of a stream of payload data to be transmitted, the command will essentially be executed in the order it is received. If the radio is continuously receiving data, the radio will wait for a break in the received data before executing the command. The CTS signal will frame the response coming from the binary command request [Figure 3.9].

A minimum time delay of 100 μs (after the stop bit of the command byte has been sent) must be observed before the CMD pin can be de-asserted. The command executes after all parameters associated with the command have been sent. If all parameters are not received within 0.5 seconds, the modem returns to Idle Mode.

Note: When parameters are sent, they are two bytes long with the least significant byte sent first. Binary commands that return one parameter byte must be written with two parameter bytes.

Refer to p27 for a binary programming example.

Commands can be queried for their current value by sending the command logically ORed (bit-wise) with the value 0x80 (hexadecimal) with CMD asserted. When the binary value is sent (with no parameters), the current value of the command parameter is sent back through the DO pin

Figure 3.9. Binary Command Write then Read

- Signal #1 is the DIN signal to the modem
- Signal #2 is the DOUT signal from the modem
- Signal #3 is \overline{CTS}
- Signal #4 is CMD

In this graph, a value was written to a register and then read out to verify it. While not in the middle of other received data, note that the CTS signal (GPO1) outlines the data response out of the modem.

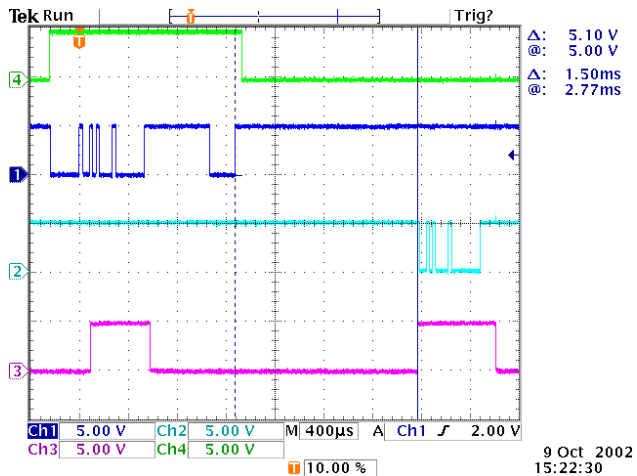

IMPORTANT: For the AWB-S Modem to recognize a binary command, the RT (GPI1 Configuration) parameter must be set to one. If binary programming is not enabled (RT != 1), the modem will not recognize the data as binary commands.

RF Communication Options

The AWB-S RF Modem can be configured to operate in any of three RF communication modes:

- Streaming
- Acknowledged
- Multi-Transmit

The mode is defined by parameters stored in the transmitting modem [see table below].

Receiving modems automatically adapt to the correct mode on a per-packet basis, based on the contents of each received packet.

Table 3.3. Mode in Relation to Transmitting Modem Parameter Values

RF Communication Mode	RR Parameter Value	MT Parameter Value
Streaming	0	0
Acknowledged	>= 1	0
Multi-Transmit	ignored	>=1

Addressing Options

Transmissions can be addressed to a specific modem or group of modems using the DT (Destination Address) and MK (Address Mask) commands. A receiving modem will only accept a packet if it determines the packet is addressed to it, either as a global or local packet. The receiving modem makes this determination by inspecting the destination address of the packet and comparing it to its own address and address mask [Figure 3.10].

Figure 3.10. Address Recognition (@ RX Modem)

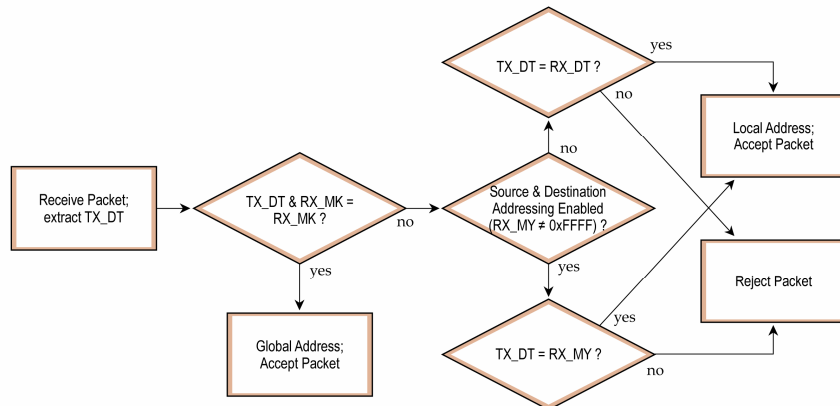

The transmitting modem determines whether the packet is intended for a specific node (local address) or multiple nodes (global address) by comparing the packet's destination address (DT) and its own address mask (MK) [Figure 3.11]. It is assumed that the address masks on the transmitting modem and receiving modem have been programmed to the same value for proper operation in each RF Communication Mode.

Figure 3.11. Address Recognition (@ TX Modem)

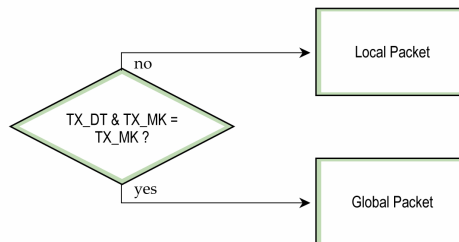

Streaming Mode

Attributes: Highest data throughput
 Lowest latency and jitter
 Reduced immunity to interference
 Streaming mode transmissions never acknowledged by receiving modem(s)

Required Parameter Values (TX Modem): RR (Retries) = 0

Related Commands: Networking (DT, MK, MY), Serial Interfacing (PK, RB, RO, TT)

Recommended Use: Mode is most appropriate for data that is more sensitive to latency and/or jitter than it is to occasional packet loss. For example: streaming audio or video.

Streaming Mode Connection Sequence

Events up through the 'Transmit Packet' process are common to all three RF Communication Options. Refer to the Transmit Mode section [p14] for more information.

When streaming data, RB and RO parameters are used only on the first packet. After transmission begins, the TX event will continue uninterrupted until the DI buffer is empty or the streaming limit (TT Command) is reached. As with the first packet, the payload of each subsequent packet includes up to the maximum packet size (PK Command).

The streaming limit is specified by the transmitting modem as the maximum number of bytes the transmitting modem can send in one transmission event. If the TT parameter is reached, the transmitting modem will force a random delay of 1 to RN delay slots (exactly 1 delay slot if RN=0).

Subsequent packets are sent without an RF initializer since receiving modems stay synchronized with the transmitting modem for the duration of the transmission event (from preceding packet information). However, due to interference, some receiving modems may lose data (and synchronization to the transmitting modem), particularly during long transmission events.

Once the transmitting modem has sent all pending data or has reached the TT limit, the transmission event ends. The transmitting modem will not transmit again for exactly RN delay slots if the local (i.e. transmitting modem's) RN parameter is set to a non-zero value. The receiving modem(s) will not transmit for a random number of delay slots between 0 and (RN-1) if the local (i.e. receiving modem's) RN parameter is set to a non-zero value. These delays are intended to lessen congestion following long bursts of packets from a single transmitting modem, during which several receiving modems may have become ready to transmit.

Figure 3.12. Streaming Mode State Diagram

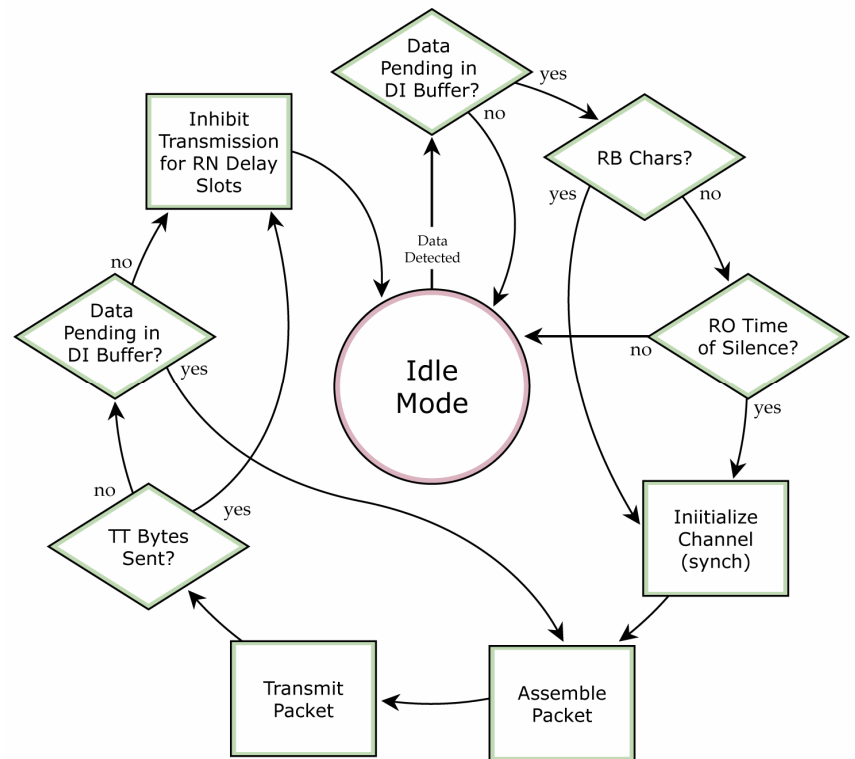

Acknowledged Mode

Attributes: Reliable delivery through positive acknowledgements for each packet
Throughput, latency and jitter vary depending on the quality of the channel and the strength of the signal.

Required Parameter Values (TX Modem): RR (Retries) ≥ 1

Related Commands: Networking (DT, MK, RR), Serial Interfacing (PK, RN, RO, RB, TT)

Recommended Use: Use for applications that require Reliable Delivery. If messages are smaller than 256 bytes, use RB and RO commands to align RF packets to application packets.

Acknowledged Mode Connection Sequence

Events up through the 'Transmit Packet' process are common to all three RF Communication Options. Refer to the Transmit Mode section [p14] for more information.

After sending a packet while in acknowledged mode, the transmitting modem listens for an acknowledgement. If it receives the ACK, it will either move on to sending a subsequent packet (if more transmit data is pending), or will wait for exactly RN random delay slots before allowing another transmission (if no more data is pending to be transmitted).

If the transmitting modem does not receive the ACK within the allotted time, it will retransmit the packet with a new RF initializer following the ACK slot. There is no delay between the first ACK slot and the first retransmission. Subsequent retransmissions incur a delay of a random number of delay slots, between 0 and RN. If RN is set to 0 on the transmitting modem, there are never any back-off delays between retransmissions.

Note that during back-off delays, the transmitting modem will go into Idle Mode and may receive RF data. This can have the effect of increasing the back-off delay, as the radio cannot return to RF transmit (or retransmit) mode as long as it is receiving RF data.

After receiving and acknowledging a packet, the receiving modem will move to the next frequency and listen for either a retransmission or new data, for a specific period of time. Even if the transmitting modem has indicated that it has no more pending transmit data, it may have not received the previous ACK, and so may retransmit the packet, possibly with no delay after the ACK slot. In this case, the receiving modem will always detect the immediate retransmission, which will hold off the communications channel and thereby reduce collisions. Receiving modems acknowledge each retransmission they receive, but they only pass the first copy of a packet they receive out the UART.

Figure 3.13. Acknowledged Mode State Diagram

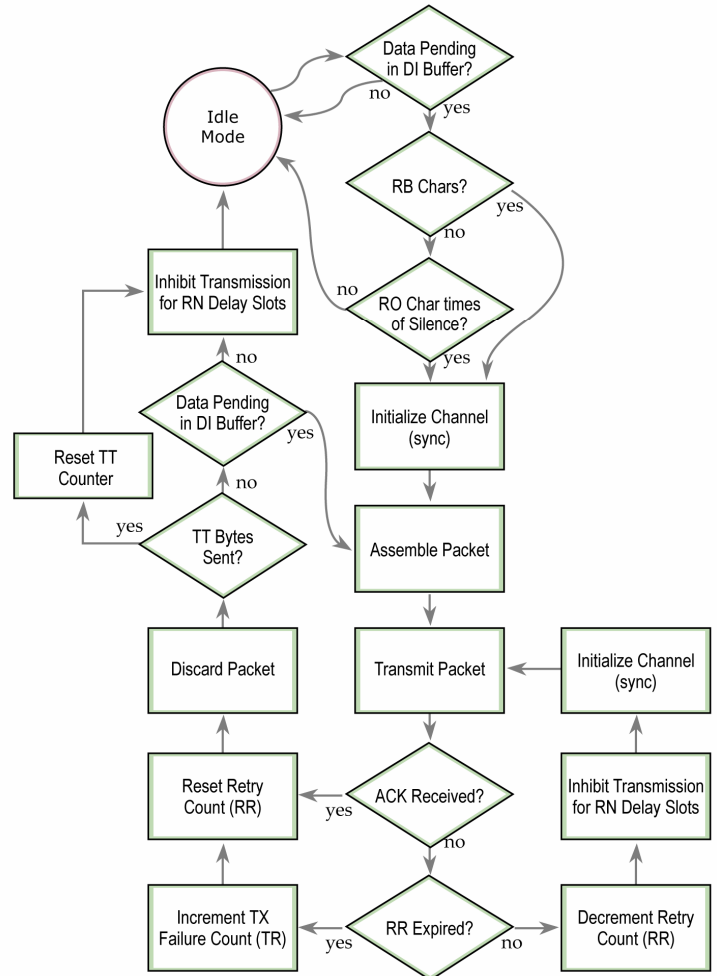

RB and RO parameters are not applied to subsequent packets, meaning that once transmission has begun, it will continue uninterrupted until the DI buffer is empty or the streaming limit (TT) has been reached. As with the first packet, the payload of each subsequent packet includes up to the maximum packet size (PK), and the transmitting modem checks for more pending data near the end of each packet.

The streaming limit (TT) specifies the maximum number of bytes that the transmitting modem will send in one transmission event, which may consist of many packets and retries. If the TT parameter is reached, the transmitting modem will force a random delay of 1 to RN delay slots (exactly 1 delay slot if RN is zero). Each packet is counted only once toward TT, no matter how many times the packet is retransmitted.

Subsequent packets in acknowledged mode are similar to those in streaming mode, with the addition of an acknowledgement between each packet, and the possibility of retransmissions. Subsequent packets are sent without an RF initializer, as the receiving modems are already synchronized to the transmitting modem from the preceding packet(s) and they remain synchronized for the duration of the transmission event. Each retransmission of a packet includes an RF initializer.

Once the transmitting modem has sent all pending data or has reached the TT limit, the acknowledged transmission event is completed. The transmitting modem will not transmit again for exactly RN delay slots, if the local RN parameter is set to a nonzero value. The receiving modem will not transmit for a random number of delay slots between 0 and (RN-1), if the local RN parameter is set to a nonzero value. These delays are intended to lessen congestion following long bursts of packets from a single transmitting modem, during which several receiving modems may have themselves become ready to transmit.

Multi-Transmit Mode

Attributes: Reliable Delivery through forced transmission of every RF packet
 Every RF packet is sent exactly (MT + 1) times with no delays between packets
 Diminished throughput and increased latency

Required Parameter Values (TX Modem): MT (Multi-Transmit) >= 1

Other Related Commands: Networking (DT, MK, MY, RN, TT), Serial Interfacing (BR, PK, RB, RO), RF Interfacing (FS)

Recommended Use: Use for applications that require Reliable Delivery without using retries and acknowledgements.

Multi-Transmit Mode Connection Sequence

Events up through the 'Transmit Packet' process are common to all three RF Communication Options. Refer to the Transmit Mode section [p14] for more information.

In Multi-Transmit mode, each packet is retransmitted MT times, for a total of (MT+1) transmissions. There is no delay between retransmissions, and the transmitting modem will never receive RF data between retransmissions. Each retransmission includes an RF initializer. A transmission event may include follow-on packets, each of which will be retransmitted MT times. The Forced Sync (FS) parameter is ignored in multiple-transmission mode.

The RB and RO parameters are not applied to follow-on packets, meaning that once transmission has begun, it will continue uninterrupted until the DI buffer is empty or the streaming limit (TT) has been reached. As with the first packet, the payload of each follow-on packet includes up to the maximum packet size (PK) bytes, and the transmitting modem checks for more pending data near the end of each packet. Follow-on packets are not sent until all retransmissions of the previous packet are finished.

The streaming limit (TT) is specified at the transmitting modem as the maximum number of bytes that the transmitting modem can send in one transmission event, which may consist of many packets. If the TT parameter is reached, the transmitting modem will force a random delay of 1 to RN delay slots (exactly 1 delay slot if RN is zero). In Multi-Transmit mode, each packet is counted only once when tracking the streaming limit (TT), no matter how many times it is retransmitted.

When a receiving modem receives a Multi-Transmit packet, it calculates the amount of time remaining in the Multi-Transmit event, and inhibits its own transmissions for the duration of the Multi-Transmit event, plus a random number of delay slots between 0 and (RN-1). If the local RN parameter is zero, the delay is only for the calculated duration of the Multi-Transmit event. Thus, a receiving modem need only receive one of the transmissions, and it will keep off the channel until the transmitting modem is done. If follow-on packets are coming, the receiving modems will move to the new frequency and listen for the follow-on packet for a specific period of time.

Figure 3.14. Multi-Transmit Mode State Diagram

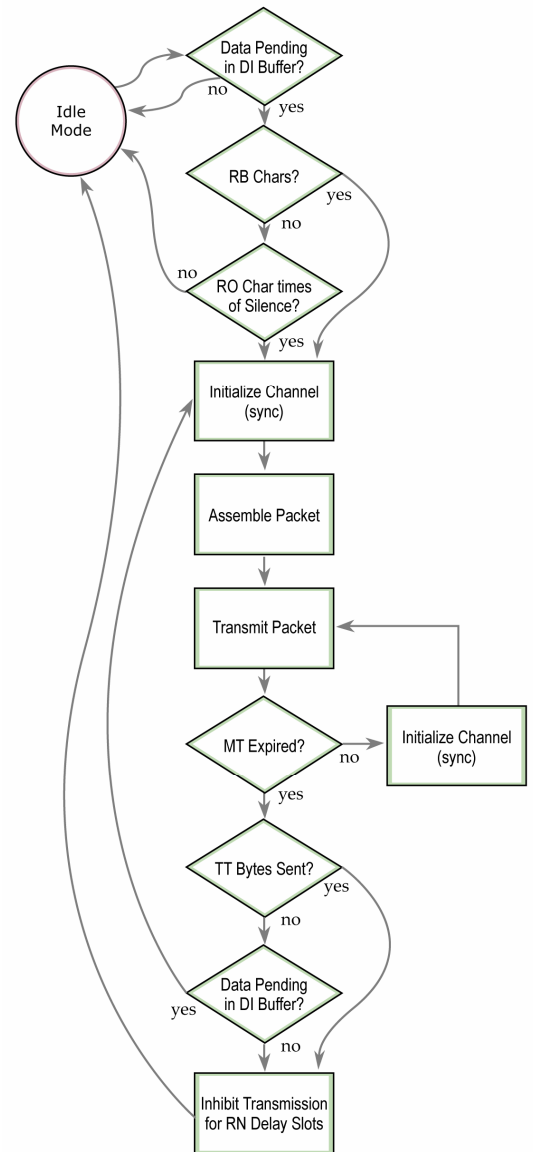

4. Advanced Programming

Automatic DIP Switch Configurations

Each time an RF Modem is powered on, intelligence inside the modem sends AT Commands that program the modem according to the positions of the DIP switch. DIP switch configurations are sent automatically during the power-on sequence and affect modem parameter values as shown in the table below.

Figure 4.1. DIP Switch

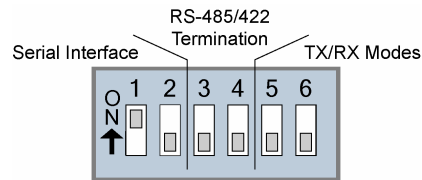

Table 4.1. Power-up Options - Commands sent as result of DIP Switch Settings
(SW = DIP Switch)

Switches	Condition	Behavior	Commands Sent During Power-up
Switches 1 & 2 (Restore Defaults / Serial Interfacing)	If SW1 & SW2 are ON (up)	Restore Defaults	ATRE (Restore Defaults) ATWR (Write defaults to non-volatile memory)
	If SW1 is ON (up)	RS-232 Operation	ATCS 0 (CTS function for CTS line)
	If SW1 is OFF (down)	RS-485 or RS-422 Operation	ATCS 3 (RS-485 or RS-422 Operation)
Switches 5 & 6 (TX/RX Modes)	If SW5 & SW6 are OFF (down)	Multipoint Base	ATMY 0 (Source Address) ATDT 0xFFFF (Destination Address) ATMT 3 (Multi-Transmit option)
	If SW5 is OFF (down) & SW6 is ON (up)	Multipoint Remote	ATAM (Auto-set MY, MY = unique) ATDT 0 (Destination Address) ATMT 0 (Multi-Transmit option) ATRR 0x0A (Retries)
	If SW5 is ON (up) & SW6 is OFF (down)	Point-to-Point	ATAM (Auto-set MY, MY = unique) ATDT 0xFFFF (Destination Address) ATMT 3 (Multi-Transmit option)
	If SW5 is ON (up) & SW6 is ON (up)	Processor is disabled and AT Commands are not sent to the RF Modem	

IMPORTANT: To avoid overwriting previously stored custom configurations (due to the automatic configurations that take place each time the RF modem is powered-on), it is necessary to disable a processor located inside the RF modem. To disable the processor, keep switches 5 & 6 ON (up) as indicated in the table.

Programming the AWB-S RF Modem

For information about entering and exiting AT and Binary Command Modes, refer to the Command Mode section [p18].

AT Command Examples (AWBridge Software)

Adalet Wireless has provided AWBridge software for programming the modem using an extensive list of AT Commands. The AWBridge software provides an interface that is divided into four tabs that facilitate the following functions:

- PC Settings tab - Setup PC serial port to interface with an AWB-S RF Modem
- Range Test tab – Test AWB-S RF Modem's range in varying environments
- Terminal tab – Configure and read AWB-S RF Modem parameters using AT Commands
- Modem Configuration tab – Configure and read RF Modem parameters

To install the AWBridge Software:

Double-click the 'AWBridge.exe' file that is located on the Adalet Wireless CD and under the 'Downloads' section of the following web page: [coWebSite](#).

Then follow the prompts of the installation screens.

PC Settings tab

As stated in the Serial Communications section [p12]; in order to communicate data to the RF modem through the PC, baud (serial data rate), data bit, parity and stop bit settings on the PC serial port must match those of the RF modem. The 'PC Settings' tab provides a software user interface that facilitates the modification of PC serial port setting.

PC Setup

1. Set the DIP Switch to RS-232 mode. Switch 1 is ON (up) and the remaining 5 switches are OFF (down).
2. Connect the male DB-9 connector of the PC with the female DB-9 connector of the RF modem using an RS-232 cable.
3. Power the RF modem through the power connector.
4. Go to the PC Settings tab and select parameter values from the dropdown lists that match the current parameter values of the RF modem.

Figure 4.2. Setup for RF Modem Configurations through AWBridge Software

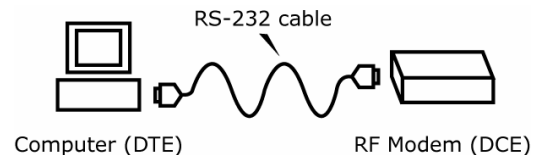

Terminal tab

A terminal program has been built into the AWBridge software and is located under the 'Terminal' tab. The Terminal tab provides an easy-to-use interface for programming the modem.

Multiple AT Commands. Multiple AT commands can be entered on one line with one carriage return at the end of the line. Each command must be delimited by a comma (spaces in between are optional). The "AT" prefix is only sent before the first command and should not be included with subsequent commands in a line.

System Response. When a command is sent to the modem, the modem will parse and execute the command. Upon successful execution of a command, the modem returns an "OK" message. If execution of a command results in an error, the modem returns an "ERROR" message.

EXAMPLE: Restore RF Modem Default Parameters using the Terminal tab:

Example: Both of the following examples change the AWB-S Modem's destination address to 0x1A0D (6669d) and save the new address to non-volatile memory.

Method 1 (One line per command)

Issue AT Command	System Response
+++	OK<CR> (Enter into AT Command Mode)
ATRE<CR>	OK<CR> (Restore modem default parameter values)
ATWR<CR>	OK<CR> (Write new values to non-volatile memory)
ATCN<CR>	OK<CR> (Exit AT Command Mode)

Method 2 (Multiple commands on one line)

Issue AT Command	System Response
+++	OK<CR>
ATRE, WR, CN<CR>	OK<CR>

NOTE: Default parameter values of the RF Modem can also be restored by selecting the 'Restore' button located on the Modem Configuration tab.

Modem Configuration tab

While AWB-S RF Modems operate out-of-box without configuration, the 'Modem Configuration' tab of the AWBridge software can be used to activate advanced functions. The following example illustrates use of the most commonly used features of the Modem Configuration tab.

EXAMPLE: Read & Restore Default Parameters using the Modem Configuration tab:

The following steps show how to read currently stored modem parameter values; then restore the modem parameters to their factory-default states.

1. Open the AWBridge program:
2. Under the "PC Settings" tab, select the PC Serial Com Port from the dropdown list that will be used to connect to the RF Modem.
3. Select a "Baud rate" to match the default RF data rate of the RF Modem. Use default values for all other fields.
4. Select the "Modem Configuration" tab.
5. Select the "Read" button to read currently stored parameter values of the modem.
6. Select the "Restore" button to restore factory-default parameter values.
7. Select the "Write" button to save default values to non-volatile memory.

Binary Command Example**To Send Binary Commands:**

Example: Use binary commands to change the AWB-S Modem's destination address to 0x1A0D and save the new address to non-volatile memory.

1. RT Command must be set to "1" in AT Command Mode to enable binary programming.
2. Assert CMD (Pin is driven high). (Enter Binary Command Mode)
3. Send Bytes: 00 (Send DT (Destination Address) Command)
0D (Least significant byte)
1A (Most significant byte)
08 (Send WR (Write) Command)
4. De-assert CMD (Pin is driven low). (Exit Binary Command Mode)

Note: $\overline{\text{CTS}}$ is high when command is being executed. Hardware flow control must be disabled as $\overline{\text{CTS}}$ will hold off parameter bytes.

Command Descriptions (Short)

Table 4.2. AWB-S Commands (“d” denotes decimal equivalent)

AT Command	Binary Command	AT Command Name	Parameter Range	Command Category	# Bytes Returned	Factory Default
%V	0x3B (59d)	Board Voltage	0x2CCCA – 0x5BFFA [read-only]	Diagnostics	4	-
AM	0x40 (64d)	Auto-set MY	0 – 0xFFFF	Networking & Security	2	-
AT	0x05 (5d)	Guard Time After	2 - (ATST-3) [x 100 msec]	Command Mode Options	2	0x0A (10d)
BD	0x15 (21d)	Baud Rate (Serial Data Rate)	0 - 8	Serial Interfacing	1	3
BR	0x39 (57d)	RF Data Rate	0 - 1	RF Interfacing	1	1
BT	0x04 (4d)	Guard Time Before	0 – 0xFFFF [x 100 msec]	Command Mode Options	2	0x0A (10d)
CC	0x13 (19d)	Command Sequence Character	0x20 - 0x7F	Command Mode Options	1	0x2B [“+”] (43d)
CD	0x28 (40d)	GPO2 Configuration	0 - 2	Serial Interfacing	1	2
CF	-	Number Base	0 - 2	Command Mode Options	1	1
CN	0x09 (9d)	Exit Command Mode	-	Command Mode Options	-	-
CS	0x1F (31d)	GPO1 Configuration	0 - 4	Serial Interfacing	1	0
CT	0x06 (6d)	Command Mode Timeout	2 – 0xFFFF [x 100 ms]	Command Mode Options	2	0xC8 (200d)
DB	0x36 (54d)	Received Signal Strength	0x6E to 0x28 [read-only]	Diagnostics	2	-
DT	0x00 (0d)	Destination Address	0 - 0xFFFF	Networking & Security	2	0
E0	0x0A (10d)	Echo Off	-	Command Mode Options	-	-
E1	0x0B (11d)	Echo On	-	Command Mode Options	-	-
ER	0x0F (15d)	Receive Error Count	0 – 0xFFFF	Diagnostics	2	0
FH	0x0D (13d)	Force Wake-up Initializer	-	Sleep (Low Power)	-	-
FL	0x07 (7d)	Software Flow Control	0 - 1	Serial Interfacing	1	0
FS	0x3E (62d)	Forced Sync Time	1 – 0xFFFF [x 10 msec]	RF Interfacing	2	0
FT	0x24 (36d)	Flow Control Threshold	0 – DI Buffer size (bytes)	Serial Interfacing	2	varies
GD	0x10 (16d)	Receive Good Count	0 – 0xFFFF	Diagnostics	2	0
HP	0x11 (17d)	Hopping Channel	0 - 9	Networking & Security	1	0
HT	0x03 (3d)	Time before Wake-up Initializer	0 – 0xFFFF [x 100 msec]	Sleep (Low Power)	2	0xFFFF (65535d)
HV	-	Hardware Version	0 – 0xFFFF [read-only]	Diagnostics	2	-
ID	0x27 (39d)	Modem VID	0 - 0x7FFF (user-settable) 0x8000 - 0xFFFF (factory-set)	Networking & Security	2	0x3332 (13106d)
KY	0x3C (60d)	AES Encryption Key	0 – (Any other 64-digit hex valid key)	Networking & Security	2	0
LH	0x0C (12d)	Wake-up Initializer Timer	0 – 0xFF [x 100 msec]	Sleep (Low Power)	1	1
MK	0x12 (18d)	Address Mask	0 - 0xFFFF	Networking & Security	2	0xFFFF (65535d)
MT	0x3D (61d)	Multi-Transmit	0 – 0xFF	Networking & Security	1	0
MY	0x2A (42d)	Source Address	0 - 0xFFFF	Networking & Security	2	0xFFFF (65535d)
NB	0x23 (35d)	Parity	0 - 4	Serial Interfacing	1	0
PK	0x29 (41d)	Maximum RF Packet Size	1 – 0x800 [Bytes]	RF Interfacing	2	0x800 (2048d)
PL	0x3A (58d)	TX Power Level	0 - 4	RF Interfacing	1	4 [1 Watt]
PW	0x1D (29d)	Pin Wake-up	0 - 1	Sleep (Low Power)	1	0
RB	0x20 (32d)	Packetization Threshold	1 - Current value of PK	Serial Interfacing	2	0x800 (2048d)
RC	-	Ambient Power - Single Channel	0 – 0x31 [dBm, read-only]	Diagnostics	1	-
RE	0x0E (14d)	Restore Defaults	-	(Special)	-	-
RM	-	Ambient Power - All Channels	No parameter – 0x7D0 [read-only]	Diagnostics	2	-
RN	0x19 (25d)	Delay Slots	0 – 0xFF (slots)	Networking & Security	1	0
RO	0x21 (33d)	Packetization Timeout	0 – 0xFFFF [x UART character time]	Serial Interfacing	2	3
RP	0x22 (34d)	RSSI PWM Timer	0 – 0xFF [x 100 msec]	Diagnostics	1	0x20 (32d)
RR	0x18 (24d)	Retries	0 – 0xFF	Networking & Security	1	0x0A (10d)
RT	0x16 (22d)	GPI1 Configuration	0 - 2	Serial Interfacing	1	0
SB	0x37 (55d)	Stop Bits	0 - 1	Serial Interfacing	1	0
SH	0x25 (37d)	Serial Number High	0 – 0xFFFF [read-only]	Diagnostics	2	varies
SL	0x26 (38d)	Serial Number Low	0 – 0xFFFF [read-only]	Diagnostics	2	varies
SM	0x01 (1d)	Sleep Mode	0 - 2, 4 - 8; 3 reserved	Sleep (Low Power)	1	0
ST	0x02 (2d)	Time before Sleep	(ATAT+3) – 0x7FFF [x 100 msec]	Sleep (Low Power)	2	0x64 (100d)
TP	0x38 (56d)	Board Temperature	0 – 0x7F [read-only]	Diagnostics	1	-
TR	0x1B (27d)	Delivery Failure Count	0 – 0xFFFF [read-only]	Diagnostics	2	0
TT	0x1A (26d)	Streaming Limit	0 – 0xFFFF [0 = disabled]	Networking & Security	2	0
TX	0x3F (63d)	Transmit Only	0 - 1	RF Interfacing	1	0
VL	-	Firmware Version - verbose	Returns string	Diagnostics	-	-
VR	0x14 (20d)	Firmware Version	0 - 0xFFFF [read-only]	Diagnostics	2	-
WA	-	Active Warning Numbers	Returns string	Diagnostics	-	-
WN	-	Warning Data	Returns string	Diagnostics	-	-
WR	0x08 (8d)	Write	-	(Special)	-	-
WS	-	Sticky Warning Numbers	Returns string	Diagnostics	-	-

* Firmware version in which the command and parameter options were first supported.

Command Descriptions (long)

Commands in this section are listed alphabetically. Command categories are designated between the "< >" symbols that follow each command title. By default, AWB-S RF Modems expect numerical values in hexadecimal since the default value of the CF (Number Base) Parameter is '1'. Hexadecimal values are designated by the "0x" prefix and decimal values by the "d" suffix.

%V (Board Voltage) Command

<Diagnostics> %V Command is used to read the current voltage of the AWB-S Module circuit board.

Sample Output: 5.02 V (when ATCF = 0)
 5051F (when ATCF = 1) *
 5.02 (when ATCF = 2)

* When CF = 1 (default), a hex integer is shown that is equal to (voltage * 65536d).

AT Command: AT%V

Binary Command: 0x3B (59 decimal)

Parameter Range (read-only):

0x2CCCA – 0x5BFFA
 (2.80 – 5.75 decimal)

Number of bytes returned: 4

AM (Auto-set MY) Command

<Networking & Security> AM Command is used to automatically set the MY (Source Address) parameter from the factory-set modem serial number. The address is formed with bits 29, 28 and 13-0 of the serial number (in that order). The value is displayed as a result of this command.

AT Command: ATAM

Binary Command: 0x40 (64 decimal)

Parameter Range: 0 – 0xFFFF

AT (Guard Time After) Command

<Command Mode Options> AT Command is used to set/read the time-of-silence that follows the command sequence character (CC Command). By default, 1 second must elapse before and after the command sequence character.

Refer to the AT Commands section [p18] to view the default AT Command Mode sequence.

AT Command: ATAT

Binary Command: 0x05 (5 decimal)

Parameter Range: 2 – (ATST–3), up to 0x7FFC
 [x 100 milliseconds]

Default Parameter Value: 0x0A (10 decimal)

Number of bytes returned: 2

Related Commands: BT (Guard Time Before), CC (Command Sequence Character)

BD (Baud Rate) Command

<Serial Interfacing> BD Command is used to set/read the interface data rate (the rate at which serial data is sent to the modem from a host). Newly modified serial data rates do not take effect until the modem exits Command Mode [refer to CN (Exit Command Mode) and CT (Command Mode Timeout) Commands].

The BR (RF Data Rate) Parameter is not affected by the BD Command.

Note: If the serial data rate is set to exceed the fixed RF data rate of the AWB-S Modem, CTS flow control may need to be implemented. Refer to the Flow Control [p13] and CS (GPO1 Configuration Command [p31] sections for more information.

AT Command: ATBD

Binary Command: 0x15 (21 decimal)

Parameter Range: 0 – 8

Parameter Value	BAUD (bps) Configuration
0	1200
1	2400
2	4800
3	9600
4	19200
5	38400
6	57600
7	115200
8	230400

Default Parameter Value: 3

Number of bytes returned: 1

BR (RF Data Rate) Command

<RF Interfacing> BR Command is used to set/read the RF data rate (rate that RF data is transmitted over-the-air) of the modem.

AT Command: ATBR
 Binary Command: 0x39 (57 decimal)
 Parameter Range: 0 – 1

Parameter Value	BAUD (bps) Configuration
0	9600
1	115200

Default Parameter Value: 1
 Number of bytes returned: 1

BT (Guard Time Before) Command

<Command Mode Options> BT Command is used to set/read the time-of-silence that precedes the command sequence character (CC Command) of the AT Command Mode Sequence.

Refer to the AT Commands section [p18] to view the default AT Command Mode sequence.

AT Command: ATBT
 Binary Command: 0x04 (4 decimal)
 Parameter Range: 0 – 0xFFFF
 [x 100 milliseconds]

Default Parameter Value: 0x0A (10 decimal)

Number of bytes returned: 2

Related Commands: AT (Guard Time After), CC (Command Sequence Character)

CC (Command Sequence Character) Command

<Command Mode Options> CC Command is used to set/read the ASCII character used between Guard Times of the AT Command Mode Sequence (BT+ CC + AT). The AT Command Mode Sequence activates AT Command Mode (from Idle Mode).

Refer to the AT Commands section [p18] to view the default AT Command Mode sequence.

AT Command: ATCC
 Binary Command: 0x13 (19 decimal)
 Parameter Range: 0x20 – 0x7F
 Default Parameter Value: 0x2B (ASCII “+” sign)
 Number of bytes returned: 1

Related Commands: AT (Guard Time After), BT (Guard Time Before)

CD (GPO2 Configuration) Command

<Serial Interfacing> CD Command is used to select/read the behavior of the GPO2 line.

AT Command: ATCD
 Binary Command: 0x28 (40 decimal)
 Parameter Range: 0 – 2

Parameter Value	Configuration
0	RX LED
1	Default high
2	Default low

Default Parameter Value: 2

Number of bytes returned: 1

CF (Number Base) Command

<Command Mode Options> CF command is used to set/read command formatting setting.

The following commands are always entered and read in hex, no matter the CF setting:

VR (Firmware Version), HV (Hardware Version), KY (AES Encryption Key).

AT Command: ATCF
 Binary Command: 0x1F (31 decimal)
 Parameter Range: 0 – 2

Parameter Value	Configuration
0	Commands utilize default number base; decimal commands may output units
1	All commands are forced to unsigned, unit-less hex
2	Commands utilize their default number base; no units output

Default Parameter Value: 1

Number of bytes returned: 1

CN (Exit Command Mode) Command

<Command Mode Options> CN Command is used to explicitly exit AT Command Mode.

AT Command: ATCN
 Binary Command: 0x09 (9 decimal)

CS (GP01 Configuration) Command

<Serial Interfacing> CS Command is used to select the behavior of the GP01 pin. This output can provide RS-232 flow control, control the TX enable signal (for RS-485 or RS-422 operations), or set the default level for the I/O line passing function.

By default, GP01 provides RS-232 $\overline{\text{CTS}}$ (Clear-to-Send) flow control.

AT Command: ATCS
 Binary Command: 0x1F (31 decimal)
 Parameter Range: 0 – 4

Parameter Value	Configuration
0	RS-232 $\overline{\text{CTS}}$ flow control
1	RS-485 TX enable low
2	high
3	RS-485 TX enable high
4	low

Default Parameter Value: 0
 Number of bytes returned: 1
 Related Commands: RT (GPI1 Configuration), TO (GP01 Timeout)

DB (Received Signal Strength) Command

<Diagnostics> DB Command is used to read the receive signal strength (in decibels relative to milliWatts) of the last received packet. This parameter is useful in determining range characteristics of AWB-S Modems under various conditions.

In default mode, this command shows the power level in signed decimal format, with the units (dBm). If CF is set to 1, the magnitude of the value is presented in unsigned hex. If CF is set to 2, the value is presented in decimal, but without the units.

Sample Output: -88 dBm (when ATCF = 0)
 58 (when ATCF = 1)
 -88 (when ATCF = 2)

AT Command: ATDB
 Binary Command: 0x36 (54 decimal)
 Parameter Range (read-only):
 0x6E – 0x28
 (-110 to -40 Decimal)
 Number of bytes returned: 2
 Related Command: CN (Exit Command Mode)

NOTE: If the DB register is read before the modem has received an RF packet, the modem will return a value of 0x8000 (which means no packets have yet been received).

DT (Destination Address) Command

<Networking & Security> DT Command is used to set/read the networking address of the AWB-S Modem. AWB-S Modems uses three network layers –Vendor Identification Number (ATID), Channels (ATHP), and Destination Addresses (ATDT). DT Command assigns an address to a modem that enables it to communicate only with other modems having the same addresses. All modems that share the same Destination Address can communicate freely with each other.

Modems in the same network with a different Destination Address (than that of the transmitter) will listen to all transmissions to stay synchronized, but will not send any of the data out their serial ports.

AT Command: ATDT
 Binary Command: 0x00
 Parameter Range: 0 – 0xFFFF
 Default Parameter Value: 0
 Number of bytes returned: 2
 Related Commands: HP (Hopping Channel), ID (Modem VID), MK (Address Mask)

E0 (Echo Off) Command

<Command Mode Options> E0 Command turns off character echo in AT Command Mode. By default, echo is off.

AT Command: ATE0
Binary Command: 0x0A (10 decimal)

E1 (Echo On) Command

<Command Mode Options> E1 Command turns on the character echo in AT Command Mode. Each typed character will be echoed back to the terminal when ATE1 is active. E0 is the default.

AT Command: ATE1
Binary Command: 0x0B (11 decimal)

ER (Receive Error Count) Command

<Diagnostics> Set/Read the number of receive-errors. The error count records the number of packets partially received then aborted on a reception error. This value returns to 0 after a reset and is not non-volatile (Value does not persist in the modem’s memory after a power-up sequence). Once the Receive Error Count reaches its maximum value (up to 0xFFFF), it remains at its maximum count value until the maximum count value is explicitly changed or the modem is reset.

AT Command: ATER
Binary Command: 0x0F (15 decimal)
Parameter Range: 0 – 0xFFFF
Default Parameter Value: 0
Number of bytes returned: 2
Related Commands: GD (Receive Good Count)

The ER parameter is not reset by pin, serial port or cyclic sleep modes.

FH (Force Wake-up Initializer) Command

<Sleep (Low Power)> FH Command is used to force a Wake-up Initializer to be sent on the next transmission. WR (Write) Command does not need to be issued with FH Command.

AT Command: ATFH
Binary Command: 0x0D (13 decimal)

Use only with cyclic sleep modes active on remote modems.

FL (Software Flow Control) Command

<Serial Interfacing> FL Command is used to configure software flow control. Hardware flow control is implemented with the AWB-S Modem as the GP01 pin ($\overline{\text{CTS}}$), which regulates when serial data can be transferred to the modem.

FL Command can be used to allow software flow control to also be enabled. XON character used is 0x11 (17 decimal). XOFF character used is 0x13 (19 decimal).

AT Command: ATFL
Binary Command: 0x07 (7 decimal)
Parameter Range: 0 – 1

Parameter Value	Configuration
0	Disable software flow control
1	Enable software flow control

Default Parameter Value: 0
Number of bytes returned: 1

FS (Forced Synch Time) Command

<RF Interfacing> FS Command only applies to streaming data. Normally, only the first packet of a continuous stream has the full RF initializer. The modems then remain synchronized for subsequent packets of the stream. This parameter can be used to periodically force an RF initializer during such streaming. Any break in UART character reception long enough to drain the DI Buffer (UART receive buffer) and cause a pause in RF data transmission will also cause an RF initializer to be inserted on the next transmission.

AT Command: ATFS
Binary Command: 0x3E (62 decimal)
Parameter Range: 0 – 0xFFFF
[x 10 milliseconds]
Default Parameter Value: 0
Number of bytes returned: 2

FT (Flow Control Threshold) Command

<Serial Interfacing> Set/Read the flow control threshold. When FT bytes have accumulated in the DI buffer, \overline{CTS} is de-asserted or the XOFF software flow control character is transmitted.

AT Command: ATFT

Binary Command: 0x24 (36 decimal)

Parameter Range: 0 – (Receive buffer size minus 0x11 bytes)

Default Parameter Value: DO Buffer size minus 0x11 (decimal 17)

Number of bytes returned: 2

GD (Receive Good Count) Command

<Diagnostics> Set/Read the count of good received RF packets. Parameter value is reset to 0 after every reset and is not non-volatile (Value does not persist in the modem's memory after a power-up sequence). Once the "Receive Good Count" reaches its maximum value (up to 0xFFFF), it remains at its maximum count value until the maximum count value is manually changed or the modem is reset.

The GD parameter is not reset by pin, serial port or cyclic sleep modes.

AT Command: ATGD

Binary Command: 0x10 (16 decimal)

Parameter Range: 0 – 0xFFFF

Default Parameter Value: 0

Number of bytes returned: 2

Related Commands: ER (Receive Error Count)

HP (Hopping Channel) Command

<Networking & Security> HP Command is used to set/read the modem's hopping channel number. A channel is one of three layers of addressing available to the AWB-S Modem.

In order for modems to communicate with each other, the modems must have the same channel number since each channel uses a different hopping sequence. Different channels can be used to prevent modems in one network from listening to transmissions of another.

AT Command: ATHP

Binary Command: 0x11 (17 decimal)

Parameter Range: 0 – 9

Default Parameter Value: 0

Number of bytes returned: 1

Related Commands: ID (Modem VID), DT (Destination Address), MK (Address Mask)

HT (Time before Wake-up Initializer) Command

<Sleep (Low Power)> Set/read time of inactivity (no serial or RF data is sent or received) before a wake-up initializer is sent by a TX modem. HT should be set shorter than inactivity timeout [ST Command] time of any RX modems operating in Cyclic Sleep (SM=4-8). The wake-up initializer sent by the TX modem instructs all RX modems to remain awake to receive RF data.

From the RX modem perspective: After HT time elapses and the inactivity timeout [ST Command] is met, the RX modem goes into cyclic sleep. In cyclic sleep, the RX modem wakes once per sleep interval [SM Command] to check for a wake-up initializer. When a wake-up initializer is detected, the modem stays awake to receive data. The wake-up initializer must be longer than the cyclic sleep interval to ensure that sleeping modems detect incoming data.

When HT time elapses, the TX modem knows it needs to send a wake-up Initializer for all RX modems to remain awake and receive the next transmission.

AT Command: ATHT

Binary Command: 0x03 (3 decimal)

Parameter Range: 0 – 0xFFFF
[x 100 milliseconds]

Default Parameter Value: 0xFFFF (wake-up initializer will not be sent)

Number of bytes returned: 2

Related Commands: LH (Wake-up Initializer Timer), SM (Sleep Mode), ST (Time before Sleep)

HV (Hardware Version) Command

<Diagnostics> HV Command is used to read the hardware version of the modem.

AT Command: ATHV
 Parameter Range (read-only): 0 – 0xFFFF
 Number of bytes returned: 2

ID (Modem VID) Command

<Networking & Security> ID Command is used to set/read the VID (Vendor Identification Number) of the modem. Modems must have matching VIDs in order to communicate.

AT Command: ATID
 Binary Command: 0x27 (39 decimal)
 Parameter Range:
 0 – 0x7FFF (user-settable)
 0x8000 – 0xFFFF (factory-set)
 Default Parameter Value: 0x3332 (13106d)
 Number of bytes returned: 2

KY (AES Encryption Key) Command

<Networking & Security> KY Command is used to set the 256-bit AES (Advanced Encryption Standard) key for encryption/decryption of data. Once set, the key cannot be read out of the modem by any means. The entire payload of the packet is encrypted using the key and the CRC is computed across the ciphertext. When encryption is turned on, each packet carries an additional 16 bytes to convey the random CBC Initialization Vector (IV) to the receiver(s).

AT Command: ATKY
 Binary Command: 0x3C (60 decimal)
 Parameter Range:
 0 – (any other 64-digit hex valid key)
 Default Parameter Value: 0 (disabled)
 Number of bytes returned: 2
 Number Base: Always Hexadecimal

A modem with the wrong key (or no key) will still receive encrypted data, but the resultant data driven out the serial port will be meaningless. Likewise, a modem with a key will still receive unencrypted data sent from a modem without a key, but the output will be meaningless.

Because CBC mode is utilized, repetitive data appears different in different transmissions due to the randomly-generated IV.

LH (Wake-up Initializer Timer) Command

<Sleep (Low Power)> LH Command is used to set/read the duration of time for which the wake-up initializer is sent. When receiving modems are put into Cyclic Sleep Mode, they power-down after a period of inactivity [specified by ST (Time before Sleep) Command] and will periodically awaken and listen for transmitted data. In order for the receiving modems to remain awake, they must detect ~35ms of the wake-up initializer.

AT Command: ATLH
 Binary Command: 0x0C (12 decimal)
 Parameter Range: 0 – 0xFF
 [x 100 milliseconds]
 Default Parameter Value: 1
 Number of bytes returned: 1
 Related Commands: HT (Time before Wake-up Initializer), SM (Sleep Mode), ST (Time before Sleep)

LH Command must be used whenever a receiver is operating in Cyclic Sleep Mode. This lengthens the Wake-up Initializer to a specific amount of time (in tenths of a second). The Wake-up Initializer Time must be longer than the cyclic sleep time that is determined by SM (Sleep Mode) Command. If the wake-up initializer time were less than the Cyclic Sleep interval, the connection would be at risk of missing the wake-up initializer transmission.

Refer to Figures 4.3 & 4.4 of the SM Command description to view diagrams of correct and incorrect configurations. The images help visualize the importance that the value of LH be greater than the value of SM.

MK (Address Mask) Command

<Networking & Security> MK Command is used to set/read the "Address Mask". All data packets contain the Destination Address of the transmitting modem.

When an RF data packet is received, the transmitter's Destination Address is logically "ANDed" (bitwise) with the Address Mask of the receiver. The resulting value must match the Destination Address or the Address Mask of the receiver for the packet to be received and sent out the modem's DO serial port. If the "ANDed" value does not match either the Destination Address or the Address Mask of the receiver, the packet is discarded. (All "0" values are treated as "irrelevant" values and are ignored.)

AT Command: ATMK

Binary Command: 0x12 (18 decimal)

Parameter Range: 0 – 0xFFFF

Default Parameter Value: 0xFFFF (65535d)

Destination address (DT parameter) of the transmitting modem must exactly match the destination address of the receiving modem.

Number of bytes returned: 2

Related Commands: DT (Destination Address), HP (Hopping Channel), ID (Modem VID), MY (Source Address)

MT (Multi-Transmit) Command

<Networking & Security> MT packets do not request an acknowledgement from the receiving modem(s). MT takes precedence over RR, so if both MT and RR are non-zero, then MT+1 packets will be sent, with no ACK requests.

When a receiving modem receives a packet with remaining forced retransmissions, it calculates the length of the packet and inhibits transmission for the amount of time required for all retransmissions. Thereafter, a random number of delay slots are inserted between 0 and RN before transmission is allowed from the receiving modem(s). This prevents all listening modems from transmitting at once upon conclusion of a multiple transmission event, as long as RN is non-zero.

Comment: Actual number of forced transmissions is the parameter value plus one. For example, if MT=1, two transmissions of each packet will be sent.

AT Command: ATMT

Binary Command: 0x3D (61 decimal)

Parameter Range: 0 – 0xFF

Default Parameter Value: 0 (no forced retransmissions)

Number of bytes returned: 1

Related Commands: Networking (DT, MK, MY, RN, TT), Serial Interfacing (BR, PK, RB, RO), RF Interfacing (FS)

MY (Source Address) Command

<Networking & Security> Set/Read the source address of the modem.

AT Command: ATMY

Binary Command: 0x2A (42 decimal)

Parameter Range: 0 – 0xFFFF

Default Parameter Value: 0xFFFF (Disabled – DT (Destination Address) parameter serves as both source and destination address.)

Number of bytes returned: 2

Related Commands: DT (Destination Address), HP (Hopping Channel), ID (Modem VID), MK (Address Mask)

NB (Parity) Command

<Serial Interfacing> Select/Read parity settings for UART communications.

AT Command: ATNB

Binary Command: 0x23 (35 decimal)

Parameter Range: 0 – 4

Parameter Value	Configuration
0	8-bit (no parity or 7-bit (any parity))
1	8-bit even
2	8-bit odd
3	8-bit mark
4	8-bit space

Default Parameter Value: 0

Number of bytes returned: 1

PK (Maximum RF Packet Size) Command

<RF Interfacing> PK Command is used to set/read the maximum size of RF packets. The maximum packet size can be used along with RB/RO to implicitly set the channel dwell time.

If PK is set above 256 and BR is subsequently changed to 0, then PK will automatically be lowered to 256 and a warning will be raised (see BR (RD Data Rate) and WN (Warning Data) Commands for details).

Changes to this parameter may have a secondary effect on the RB (Packet Control Characters) Parameter. RB must always be less than or equal to PK. If PK is changed to a value less than the current value of RB, RB is automatically lowered to be equal to PK.

* When BR = 0, the maximum PK value is 0x100 (256d). When BR = 1, the maximum PK value is 0x800 (2048d).

AT Command: ATPK

Binary Command: 0x29 (41 decimal)

Parameter Range: 0 – 0x800 [Bytes]

Default Parameter Value: 0x800* (2048 decimal)

Number of bytes returned: 2

Related Commands: BR (RF Data Rate) RB (Packetization Threshold), RO (Packetization Timeout), WN (Warning Data)

PL (Power Level) Command

<RF Interfacing> PL Command is used to set/read the power level at which the modem transmits.

AT Command: ATPL

Binary Command: 0x3A (58 decimal)

Parameter Range: 0 – 4

Parameter Value	Configuration
0	1 mW
1	10 mW
2	100 mW
3	500 mW
4	1000 mW (1 Watt)

Default Parameter Value: 4

Number of bytes returned: 1

PW (Pin Wake-up) Command

<Sleep (Low Power)> Under normal operation, a modem in Cyclic Sleep Mode cycles from an active state to a low-power state at regular intervals until data is ready to be received. If the PW Parameter is set to 1, the SLEEP Pin can be used to awaken the modem from Cyclic Sleep. If the SLEEP Pin is de-asserted (low), the modem will be fully operational and will not go into Cyclic Sleep.

Once SLEEP is asserted, the modem will remain active for the period of time specified by ST (Time before Sleep) Command, and will return to Cyclic Sleep Mode (if no data is ready to be transmitted). PW Command is only valid if Cyclic Sleep has been enabled.

AT Command: ATPW

Binary Command: 0x1D (29 decimal)

Parameter Range: 0 – 1

Parameter Value	Configuration
0	Disabled
1	Enabled

Default Parameter Value: 0

Number of bytes returned: 1

Related Commands: SM (Sleep Mode), ST (Time before Sleep)

RB (Packetization Threshold) Command

<Serial Interfacing> RF transmission will commence when data is in the DI Buffer and either of the following criteria are met:

- RO character times of silence on the UART receive lines (ignored if RO = 0)
- RB characters have been received by the UART (ignored if RB = 0)

If PK is lowered below the value of RB, RB is automatically lowered to match PK.

Note: RB and RO criteria only apply to the first packet of a multi-packet transmission. If data remains in the DI Buffer after the first packet, transmissions will continue in streaming manner until there is no data left in the DI Buffer (UART receive buffer).

AT Command: ATRB

Binary Command: 0x20 (32 decimal)

Parameter Range: 0 – Current value of PK Parameter (up to 0x800 Bytes)

Default Parameter Value: 0x800

Number of bytes returned: 2

Related Commands: BR (RF Data Rate), PK (RF Packet Size), RO (Packetization Timeout)

RC (Ambient Power – Single Channel) Command

<Diagnostics> RC Command is used to examine and report the power level on a given channel.

Sample output: -78 dBm [when CF = 0]
 4e [when CF = 1]
 -78 [when CF = 2]

AT Command: ATRC

Parameter Range (read-only): 0 – 0x31 [dBm]

Number of bytes returned: 1

Related Commands: RM (Ambient Power – All channels)

RE (Restore Defaults) Command

<Diagnostics> RE Command is used to restore all configurable parameters to factory default settings. However, RE Command will not write the default values to non-volatile (persistent) memory. Unless the WR (Write) Command is issued after the RE command, the restored default settings will not be saved in the event of modem reset or power-down.

AT Command: ATRE

Binary Command: 0x0E (14 decimal)

RM (Ambient Power – All Channels) Command

<Diagnostics> RM Command is used to examine and report the power levels on all channels. If no parameter is given, then the channels will be scanned once. If a parameter is given, the channels will be repeatedly scanned for that number of seconds (up to 2000d), and the maximum power level seen for each channel is reported (i.e. peak hold).

AT Command: ATRM
 Parameter Range (read-only): no parameter - 0x7D0 (2000d)
 Number of bytes returned: 2
 Related Commands: RC (Ambient Power – Single channel)

A graphical spectrum analyzer application can be implemented by repeatedly calling ATRM with no arguments and reading the resultant 50 power levels (easiest to do when CF = 1 or 2).

Sample output [when CF = 0]: Ch 0: -100 dBm
 Ch 1: -103 dBm
 ...
 Ch 49: -99 dBm

Sample output [when CF = 1]: 64
 67
 ...
 63

Sample output [when CF = 2]: -100
 -103
 ...
 -99

RN (Delay Slots) Command

<Networking & Security> RN Command is used to set/read the time delay that the transmitting modem inserts before attempting to resend a packet. If the transmitting modem fails to receive an acknowledgement after sending a packet, it inserts a random number of delay slots (ranging from 0 to (RN minus 1)) before attempting to resend the packet. Each delay slot lasts for a period of 38 ms.

AT Command: ATRN
 Binary Command: 0x19 (25 decimal)
 Parameter Range: 0 – 0xFF [38 ms slots]
 Default Parameter Value: 0 (no delay slots inserted)
 Number of bytes returned: 1
 Related Commands: RR (Retries), TT (Streaming Limit)

If two modems attempt to transmit at the same time, the random time delay after packet failure allows only one modem to transmit the packet successfully; while the other modem waits until the channel available for RF transmission.

RN Command is only applicable if retries have been enabled [RR (Retries) Command] or if forced delays will be inserted into a transmission [TT (Streaming Limit) Command].

RO (Packetization Timeout) Command

<Serial Interfacing> RO Command is used to set/read the Packetization Timeout setting. RF transmission commences when data is in the DI buffer and either of the following criteria are met:

- RO character times of silence on the UART receive lines (ignored if RO = 0)
- RB characters have been received by the UART (ignored if (RB = 0))

AT Command: ATRO
 Binary Command: 0x21 (33 decimal)
 Parameter Range: 0 – 0xFFFF [x UART character times]
 Default Parameter Value: 0x03 (3 decimal)
 Number of bytes returned: 2
 Related Commands: RB (Packetization Threshold)

RB and RO criteria only apply to the first packet of a multi-packet transmission. If data remains in the DI Buffer (UART receive) after the first packet, transmissions will continue in streaming manner until there is no data left in the DI Buffer (UART receive).

RO Command (continued)

When RO is the transmission-beginning criteria: The actual time between the reception of the last character from the UART and the beginning of RF transmission will be at least 800 µsec longer than the actual RO time to allow for transmission setup. Additionally, it is subject to 100 - 200 µsec of additional uncertainty, which could be significant for small values of RO at high UART bit rates.

The RO timer calculates the correct UART character time (10, 11, or 12 bits) based on the following criteria:

- 1 start bit
- 8 data bits
- 0 or 1 parity bit (as set by ATNB)
- 1 or 2 stop bits (as set by ATSB)

RP (RSSI PWM Timer) Command

RP Command is used to enable a PWM (“Pulse Width Modulation”). The pin is calibrated to show the difference between received signal strength and the sensitivity level of the modem. PWM pulses vary from zero to 95 percent. Zero percent means the received RF signal is at or below the published sensitivity level of the modem. The following table shows dB levels above sensitivity and PWM values:

AT Command: ATRP
Binary Command: 0x22 (34 decimal)
Parameter Range: 0 – 0xFF [x 100 milliseconds]
Default Parameter Value: 0x20 (32 decimal)
Number of bytes returned: 1

The total time period of the PWM output is 8.32 ms. PWM output consists of 40 steps and therefore the minimum step size is 0.208 ms.

dBm above Sensitivity	PWM percentage (high period / total period)
10	47.5
20	62.5
30	77.5

A non-zero value defines the time that PWM output is active with the RSSI value of the last received RF packet. After the set time when no RF packets are received, PWM output is set low (0 percent PWM) until another RF packet is received. PWM output is also set low at power-up. A parameter value of 0xFF permanently enables PWM output and always reflects the value of the last received RF packet.

Pin 11 of the encased OEM RF module is shared between PWM output and Config input. When the modem is powered, the Config pin is an input. During the power-up sequence, if RP parameter is a non-zero value, the Config pin is configured as an output and set low until the first RF packet is received. With a non-zero RP parameter, the Config pin is an input for RP ms after power up.

RR (Retries) Command

<Networking & Security> RR Command is used to set/read the number of retries that can be sent for a given RF packet. When RR Command is enabled (non-zero value) and when MT Command equals zero, RF packet acknowledgements and retries are enabled.

AT Command: ATRR
Binary Command: 0x18 (24 decimal)
Parameter Range: 0 – 0xFF
Default Parameter Value: 0x0A (10 decimal)
Number of bytes returned: 1

After transmitting a packet, the transmitting modem waits to receive an acknowledgement from a receiving modem. If the acknowledgement is not received in the period of time specified by RN (Delay Slots) Command, the original packet is transmitted again. The RF packet is transmitted repeatedly until an acknowledgement is received or until the packet is sent RR times.

RT (GPI1 Configuration) Command

RT Command is used to set/read the behavior of the GPI1 pin. The pin can be configured to enable binary programming or $\overline{\text{RTS}}$ flow control.

AT Command: ATRT

Binary Command: 0x16 (22 decimal)

Parameter Range: 0 – 2

Parameter Value	Configuration
0	disabled
1	Enable Binary Programming
2	Enable $\overline{\text{RTS}}$ Flow Control

Default Parameter Value: 0

Number of bytes returned: 1

SB (Stop Bits) Command

<Serial Interfacing> SB Command is used to set/read the number of stop bits in the data packets.

AT Command: ATSB

Binary Command: 0x37 (55 decimal)

Parameter Range: 0 – 1

Parameter Value	Configuration
0	1 stop bit
1	2 stop bits

Default Parameter Value: 0

Number of bytes returned: 1

SH (Serial Number High) Command

<Diagnostics> SH Command is used to set/read the serial number high word of the modem.

AT Command: ATSH

Binary Command: 0x25 (37 decimal)

Parameter Range (read-only): 0 – 0xFFFF

Number of bytes returned: 2

Related Commands: SL (Serial Number Low)

SL (Serial Number Low) Command

<Diagnostics> SL Command is used to set/read the serial number low word of the modem.

AT Command: ATSL

Binary Command: 0x26 (38 decimal)

Parameter Range (read-only): 0 – 0xFFFF

Number of bytes returned: 2

Related Commands: SH (Serial Number High)

SM (Sleep Mode) Command

<Sleep Mode (Low Power)> SM Command is used to set/read the modem’s Sleep Mode settings that configure the modem to run in states that require minimal power consumption.

Pin Sleep (SM = 1)

Next to Shutdown Mode, Pin Sleep requires the least amount of power. In order to achieve this state, SLEEP must be asserted (high). The modem remains in Pin Sleep until the SLEEP pin is de-asserted.

After enabling Pin Sleep (SM=1), GPI2 controls whether the AWB-S Modem is active or in Sleep Mode. When GPI2 is de-asserted (low), the modem is fully operational. When GPI2 is asserted (high), the modem transitions to Sleep Mode and remains in its lowest power-consuming state until the Sleep pin is de-asserted. GPI2 is only active if the modem is setup to operate in this mode; otherwise the pin is ignored.

Once in Pin Sleep Mode, GP01 (\overline{CTS}) is de-asserted (high), indicating that data should not be sent to the modem. PWR is also de-asserted (low) when the modem is in Pin Sleep Mode.

Serial Port Sleep (SM = 2)

Serial Port Sleep is a Sleep Mode in which the AWB-S Modem runs in a low power state until serial data is detected on the DI pin.

When Serial Port Sleep is enabled, the modem goes into Sleep Mode after a user-defined period of inactivity (no transmitting or receiving of data). This period of time is determined by ST (Time before Sleep) Command. Once a character is received through the DI pin, the modem returns to Idle Mode and is fully operational.

Cyclic Sleep (SM = 4-8)

Cyclic Sleep is the Sleep Mode in which the AWB-S Modem enters into a low-power state and awakens periodically to determine if any transmissions are being sent. Cyclic sleep settings wake the modem after the amount of time designated by the associated SM parameter values. If the modem detects a wake-up initializer during the time it is awake, the modem synchronizes with the transmitting modem and starts receiving data after the wake-up initializer runs its duration. Otherwise, the modem returns to Sleep Mode and continues to cycle in and out of activity until a wake-up initializer is detected. If a Cyclic Sleep setting is chosen, the ST, LH and HT parameters must also be set as described in the “Sleep Mode” section of this manual.

When Cyclic Sleep settings are enabled, the AWB-S Modem goes into Sleep Mode after a user-defined period of inactivity (no transmission or reception on the RF channel). The user-defined period is determined by ST (Time before Sleep) Command.

While the modem is in Cyclic Sleep Mode, GP01 (\overline{CTS}) is de-asserted (high) to indicate that data should not be sent to the modem during this time. When the modem awakens to listen for data, GP01 is asserted and any data received on the DI Pin is transmitted. The PWR pin is also de-asserted (low) when the modem is in Cyclic Sleep Mode.

AT Command: ATSM

Binary Command: 0x01

Parameter Range: 0 – 8

Parameter Value	Configuration
0	Disabled
1	Pin Sleep
2	Serial Port Sleep
3	reserved
4	Cyclic 1.0 second sleep (Modem wakes every 1.0 second)
5	Cyclic 2.0 second sleep
6	Cyclic 4.0 second sleep
7	Cyclic 8.0 second sleep
8	Cyclic 16.0 second sleep

Default Parameter Value: 0

Number of bytes returned: 1

Related Commands:

Pin Sleep – PC (Power-up Mode), PW (Pin Wake-up)

Serial Port Sleep – ST (Time before Sleep)

Cyclic Sleep – ST (Time before Sleep), LH (Wake-up Initializer Timer), HT (Time Before Wake-up Initializer), PW (Pin Wake-up)

SM Command (continued)

The modem remains in Sleep Mode for a user-defined period of time ranging from 0.5 seconds to 16 seconds (SM Parameters 3 through 8). After this interval of time, the modem returns to Idle Mode and listens for a valid data packet for 100 ms. If the modem does not detect valid data (on any frequency), the modem returns to Sleep Mode. If valid data is detected, the modem transitions into Receive Mode and receives incoming RF packets. The modem then returns to Sleep Mode after a Period of inactivity that is determined by ST "Time before Sleep" Command.

The modem can also be configured to wake from cyclic sleep when GPI2 (SLEEP) is de-asserted (low). To configure a modem to operate in this manner, PW (Pin Wake-up) Command must be issued. Once GPI2 is de-asserted, the modem is forced into Idle Mode and can begin transmitting or receiving data. It remains active until no data is detected for the period of time specified by the ST Command, at which point it resumes its low-power cyclic state.

Note: The cyclic interval time defined by SM (Sleep Mode) Command must be shorter than the interval time defined by LH (Wake-up Initializer Timer).

For example: If SM=4 (Cyclic 1.0 second sleep), the LH Parameter should equal 0xB ("1.1" seconds). With these parameters set, there is no risk of the receiving modem being asleep for the duration of wake-up initializer transmission. "Cyclic Scanning" explains in further detail the relationship between "Cyclic Sleep" and "Wake-up Initializer Timer"

Cyclic Scanning. Each RF transmission consists of an RF Initializer and payload. The wake-up initializer contains initialization information and all receiving modems must wake during the wake-up initializer portion of data transmission in order to be synchronized with the transmitting modem and receive the data.

Figure 4.3. Correct Configuration (LH > SM):

Length of the wake-up initializer exceeds the time interval of Cyclic Sleep. The receiver is guaranteed to detect the wake-up initializer and receive the accompanying payload data.

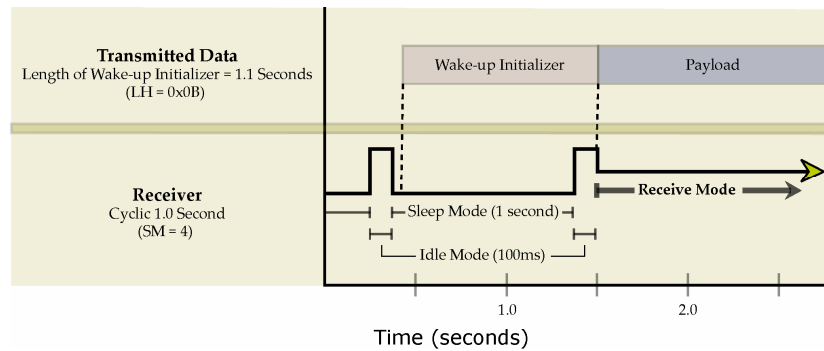
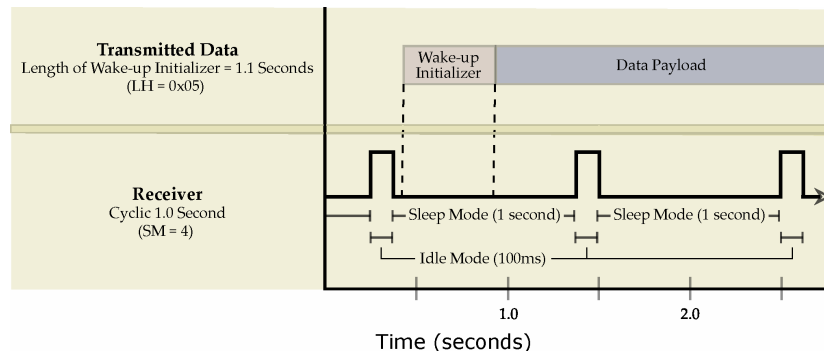

Figure 4.4. Incorrect Configuration (LH < SM):

Length of wake-up initializer is shorter than the time interval of Cyclic Sleep. This configuration is vulnerable to the receiver waking and missing the wake-up initializer (and therefore also the accompanying payload data).



ST (Time before Sleep) Command

<Sleep Mode (Low Power)> ST Command is used to set/read the period of time (milliseconds) in which the modem remains inactive before entering Sleep Mode.

For example, if the ST Parameter is set to 0x64 (100 decimal), the modem will enter into Sleep mode after 10 seconds of inactivity (no transmitting or receiving).

This command can only be used if Cyclic Sleep or Serial Port Sleep Mode settings have been selected using SM (Sleep Mode) Command.

AT Command: ATST
Binary Command: 0x02 (2 decimal)
Parameter Range: (ATAT+3) - 0x7FFF [x 100 milliseconds]
Default Parameter Value: 0x64 (100 decimal)
Number of bytes returned: 2
Related Commands: SM (Sleep Mode), LH (Wake-up Initializer Timer), HT (Time before Wake-up Initializer)

TP (Board Temperature) Command

<Diagnostics> TP Command is used to read the current temperature of the board.

Sample Output: 26 C [when ATCF = 0]
1A [when ATCF = 1]
26 [when ATCF = 2]

AT Command: ATTP
Binary Command: 0x38 (56 decimal)
Parameter Range (read-only): 0- 0x7F
Number of bytes returned: 1
Related Commands: WN (Warning Data)

TR (Transmit Error Count) Command

<Diagnostics> TR Command is used to report the number of retransmit failures. This number is incremented each time a packet is not acknowledged within the number of retransmits specified by RR (Retries) Command. It therefore counts the number of packets that were not successfully received and were subsequently dropped.

TR Parameter is not non-volatile and will therefore be reset to zero when the modem is reset.

AT Command: ATTR
Binary Command: 0x1B (27 decimal)
Parameter Range: 0 - 0xFFFF
Default Parameter Value: 0
Number of bytes returned: 2
Related Commands: RR (Retries)

TT (Streaming Limit) Command

<Networking & Security> TT Command is used to set/read the limit on the number of bytes that can be sent out before a random delay is issued.

If a modem is sending a continuous stream of RF data, a delay is inserted which stops its transmission and allows other modems time to transmit (once it sends TT bytes of data).

Inserted random delay lasts between 1 & 'RN + 1' delay slots, where each delay slot lasts 38 ms.

TT command can be used to simulate full-duplex behavior.

AT Command: ATTT
Binary Command: 0x1A (26 decimal)
Parameter Range: 0 - 0xFFFF
Default Parameter Value: 0 (disabled)
Number of bytes returned: 2
Related Commands: RN (Delay Slots)

TX (Transmit Only) Command

<RF Interfacing> TX Command is used to set/read the transmit/receive behaviors of the modem. Setting a modem to TX-only may reduce latency because the transmitting modem will never be "stuck" receiving data from other modems.

AT Command: ATTX						
Binary Command: 0x3F (63 decimal)						
Parameter Range: 0 - 1						
<table border="1"> <thead> <tr> <th>Parameter Value</th> <th>Configuration</th> </tr> </thead> <tbody> <tr> <td>0</td> <td>TX and RX</td> </tr> <tr> <td>1</td> <td>TX only</td> </tr> </tbody> </table>	Parameter Value	Configuration	0	TX and RX	1	TX only
Parameter Value	Configuration					
0	TX and RX					
1	TX only					
Default Parameter Value: 0						
Number of bytes returned: 1						

VL (Firmware Version - verbose) Command

<Diagnostics> VL Command is used to read the verbose firmware version of the AWB-S Modem.
 Sample output: Firmware version 0.8, Apr 16 2004 10:46:57

AT Command: ATVL
 Parameter Range: Returns string
 Number of bytes returned: 2

VR (Firmware Version) Command

<Diagnostics> VR Command is used to read the firmware version of the AWB-S Modem.

AT Command: ATVR
 Binary Command: 0x14 (20 decimal)
 Parameter Range (read-only): 0 – 0xFFFF
 Number of bytes returned: 2

WA (Active Warning Numbers) Command

<Diagnostics> WA Command reports the warning numbers of all active warnings - one warning number per line. No further information is shown and warning counts are not reset.

AT Command: ATWA
 Parameter Range: Returns string – one warning number per line.

Sample Output (indicates warnings 1 and 3 are currently active):
 1
 3
 OK

WN (Active Warning Numbers) Command

<Diagnostics> WN Command is used to report detailed data for all active and sticky warnings.

AT Command: ATWN
 Parameter Range: Returns string

- Warning number & description
- Number of occurrences since the last WN or WS command
- Whether the warning is currently active

Warnings which are not currently active, and have not been active since the last WN or WS command, are not displayed. WN Command also resets all non-zero warning counts, except for warnings that are presently active, which are set to 1.

Sample output: Warning 1: Under-voltage
 3 occurrences; presently active
 Warning 4: Over-temperature
 5 occurrences; presently inactive.

Warning Number	Description
1	Under-voltage. This is caused if the supply voltage falls below the minimum threshold for the lowest power level (2.8 V). If/when the voltage rises above the threshold, the warning is deactivated. The module will not transmit below this voltage threshold.
2	Over-voltage. This is caused if the supply voltage exceeds 5.75 V. Transmission is not allowed while this warning is active.
3	Under-temperature. This is caused if the temperature sensed by the module is less than -40 C. The module does not artificially limit operation while this warning is active, but module functionality is not guaranteed.
4	Over-temperature. This is caused if the temperature sensed by the module is greater than 105 C. The module does not allow transmission nor reception while this warning is active. The warning is deactivated when the temperature falls to 100 C.
5	Power reduced. This is caused if the transmit power has to be reduced from the level programmed by PL Command due to insufficient supply voltage. The 1 W power level requires 4.75 V or higher; 500 mW requires 3.0 V or higher; 100 mW, 10 mW and 1 mW require 2.8 V or higher.
6	Default calibration data in flash. This is caused if the module-specific power calibration data is either not present or is invalid, or if none of the parameters have been modified from their default values. Power levels may be incorrect.
7	Default configuration parameters in flash. This is caused if the user-modifiable parameters (i.e. those stored by a 'WR' command) in flash are all the compiled-in default values. This is caused if the user configuration is found to be not present or invalid at power-up and there is no user custom configuration, or if no user-modifiable parameters have been modified from the compiled-in defaults. Note that modification of one or more parameters without the subsequent ATWR to commit the changes to flash will not deactivate this warning, since it reflects the status of the parameters in flash. Note as well that this warning does not reflect usage of the custom configuration defaults, only usage of the compiled-in defaults.
8	Default factory configuration parameters in flash. This is caused if the factory parameters (i.e. those stored by a 'WP' command) in flash are all the default values. This is caused if the factory configuration is found to be not present or invalid at power-up, or if no factory parameters have been modified. Note that modification of one or more parameters without the subsequent ATWP to commit the changes to flash will not deactivate this warning, since it reflects the status of the parameters in flash.

WR (Write) Command

<(Special)> WR Command writes configurable parameters to the modem's non-volatile memory (Parameter values remain in the modem's memory until overwritten by future use of WR Command).

AT Command: ATWR

Binary Command: 0x08

If changes are made without writing them to non-volatile memory, the modem reverts back to previously saved parameters the next time the modem is powered-on.

WS (Sticky Warning Numbers) Command

<Diagnostics> WS Command reports the warning numbers of all warnings which have been active since the last use of WS or WN command, including any warnings which are currently active. No further information is shown.

AT Command: ATWS

Parameter Range (read-only): 1 - 8

Number of bytes returned: 1

This command also resets all non-zero warning counts, except for warnings that are presently active, which are set to 1.

Appendix A: Agency Certifications

FCC Certification

The AWB-S RF Modem complies with Part 15 of the FCC rules and regulations. Compliance with labeling requirements, FCC notices and antenna regulations is required.

Labeling Requirements

In order to inherit Adalet Wireless's FCC Certification, compliance requires the following be stated on the device and within its operation manual:

FCC ID: OUR-9XTEND

This device complies with Part 15 of the FCC Rules. Operation is subject to the following two conditions: (1) this device may not cause harmful interference and (2) this device must accept any interference received, including interference that may cause undesired operation.

Label Warning



WARNING The Original Equipment Manufacturer (OEM) must ensure that FCC labeling requirements are met. This includes a clearly visible label on the outside of the final product enclosure that displays the contents shown in the figure below.

Figure A.1. Required FCC Label for OEM products containing the AWB-S (900 MHz) OEM RF Modem

Contains FCC ID: OUR-9XTEND

The enclosed device complies with Part 15 of the FCC Rules. Operation is subject to the following two conditions: (1) this device may not cause harmful interference and (2) this device must accept any interference received, including interference that may cause undesired operation.

FCC Notices

Adherence to the following is required:

IMPORTANT: The AWB-S RF Modems have been certified by the FCC for use with other products without any further certification (as per FCC section 2.1091). Changes or modifications not expressly approved by Adalet Wireless could void the user's authority to operate the equipment.

IMPORTANT: OEMs must test their final product to comply with unintentional radiators (FCC section 15.107 and 15.109) before declaring compliance of their final product to Part 15 of the FCC Rules.

IMPORTANT: The AWB-S RF Modems have been certified for fixed base station and mobile applications. If modems will be used for portable applications, the device must undergo SAR testing.

NOTE:

This equipment has been tested and found to comply with the limits for a Class B digital device, pursuant to Part 15 of the FCC Rules. These limits are designed to provide reasonable protection against harmful interference in a residential installation. This equipment generates, uses and can radiate radio frequency energy and, if not installed and used in accordance with the instructions, may cause harmful interference to radio communications. However, there is no guarantee that interference will not occur in a particular installation. If this equipment does cause harmful interference to radio or television reception, which can be determined by turning the equipment off and on, the user is encouraged to try to correct the interference by one or more of the following measures:

- Reorient or relocate the receiving antenna.
- Increase the separation between the equipment and receiving modem.
- Connect the equipment into an outlet on a circuit different from that to which the receiving modem is connected.
- Consult the dealer or an experienced radio/TV technician for help.

Antenna Warning

 **WARNING:** This device has been tested with Reverse Polarity SMA connectors with the antennas listed in Tables A.1 – A.7 of Appendix A. When integrated into OEM products, fixed antennas require installation preventing end-users from replacing them with non-approved antennas. Antennas not listed in the tables must be tested to comply with FCC Section 15.203 (unique antenna connectors) and Section 15.247 (emissions).

FCC-Approved Antennas (900 MHz)

Fixed Base Station and Mobile Applications

Adalet Wireless Modems are pre-FCC approved for use in fixed base station and mobile applications. When the antenna is mounted at least 20 cm (8”) from nearby persons, the application is considered a mobile application.

Portable Applications and SAR Testing

When the antenna is mounted closer than 20 cm to nearby persons, then the application is considered “portable” and requires an additional test be performed on the final product. This test is called the Specific Absorption Rate (SAR) testing and measures the emissions from the modem and how they affect the person.

RF Exposure

(This statement must be included as a CAUTION statement in OEM product manuals.)

⚠ WARNING: This equipment is approved only for mobile and base station transmitting devices. Antenna(s) used for this transmitter must be installed to provide a separation distance of at least 30 cm from all persons and must not be co-located or operating in conjunction with any other antenna or transmitter.

NOTE: The separation distance indicated in the above is 30 cm, but any distance greater than or equal to 23 cm can be used (per MPE evaluation).

To fulfill FCC Certification requirements:

1. Integrator must ensure required text [Figure A.1] is clearly placed on the outside of the final product.
2. AWB-S Modem may be used only with Approved Antennas that have been tested with this modem. [Refer to Tables A.1 – A.7]

1 Watt Transmit Power Output or Lower

Table A.1. Half-wave antennas (approved when operating at 1 Watt power output or lower.)

Part Number	Type	Connector	Gain	Application
A09-HSM-7	Straight half-wave	RPSMA	3.0 dBi	Fixed / Mobile
A09-HASM-675	Articulated half-wave	RPSMA	2.1 dBi	Fixed / Mobile
A09-HABMM-P6I	Articulated half-wave w/ 6" pigtail	MMCX	2.1 dBi	Fixed / Mobile
A09-HABMM-6-P6I	Articulated half-wave w/ 6" pigtail	MMCX	2.1 dBi	Fixed / Mobile
A09-HBMM-P6I	Straight half-wave w/ 6" pigtail	MMCX	2.1 dBi	Fixed / Mobile
A09-HRSM	Right angle half-wave	RPSMA	2.1 dBi	Fixed
A09-HASM-7	Articulated half-wave	RPSMA	2.1 dBi	Fixed
A09-HG	Glass mounted half-wave	RPSMA	2.1 dBi	Fixed
A09-HATM	Articulated half-wave	RPTNC	2.1 dBi	Fixed
A09-H	Half-wave dipole	RPSMA	2.1 dBi	Fixed

Table A.2. Yagi antennas (approved when operating at 1 Watt power output or lower.)

Part Number	Type	Connector	Gain	Required Antenna Cable Loss	Application
A09-Y6	2 Element Yagi	RPN	6.1 dBi	- 0.1 dB*	Fixed / Mobile
A09-Y7	3 Element Yagi	RPN	7.1 dBi	- 1.1 dB*	Fixed / Mobile
A09-Y8	4 Element Yagi	RPN	8.1 dBi	- 2.1 dB*	Fixed / Mobile
A09-Y6TM	2 Element Yagi	RPTNC	6.1 dBi	- 0.1 dB*	Fixed / Mobile
A09-Y7TM	3 Element Yagi	RPTNC	7.1 dBi	- 1.1 dB*	Fixed / Mobile
A09-Y8TM	4 Element Yagi	RPTNC	8.1 dBi	- 2.1 dB*	Fixed / Mobile

* FCC regulations stipulate a 36 dBm EIRP power requirement. Users implementing antenna gain greater than 6.0 dB must compensate for the added gain with cable loss. When operating at 1 W power output, the sum (in dB) of cable loss and antenna gain shall not exceed 6.0 dB.

Table A.3. Omni-directional base station antennas (approved when operating at 1 Watt power output or lower.)

Part Number	Type	Connector	Gain	Required Antenna Cable Loss	Application
A09-F0	Fiberglass Base Station	RPN	0 dBi	-	Fixed
A09-F1	Fiberglass Base Station	RPN	1.0 dBi	-	Fixed
A09-F2	Fiberglass Base Station	RPN	2.1 dBi	-	Fixed
A09-F3	Fiberglass Base Station	RPN	3.1 dBi	-	Fixed
A09-F4	Fiberglass Base Station	RPN	4.1 dBi	-	Fixed
A09-F5	Fiberglass Base Station	RPN	5.1 dBi	-	Fixed
A09-F6	Fiberglass Base Station	RPN	6.1 dBi	- 0.1 dB*	Fixed
A09-F7	Fiberglass Base Station	RPN	7.1 dBi	- 1.1 dB*	Fixed
A09-F8	Fiberglass Base Station	RPN	8.1 dBi	- 2.1 dB*	Fixed
A09-W7	Wire Base Station	RPN	7.1 dBi	- 1.1 dB*	Fixed
A09-F0	Fiberglass Base Station	RPSMA	0 dBi	-	Fixed
A09-F1	Fiberglass Base Station	RPSMA	1.0 dBi	-	Fixed
A09-F2	Fiberglass Base Station	RPSMA	2.1 dBi	-	Fixed
A09-F3	Fiberglass Base Station	RPSMA	3.1 dBi	-	Fixed
A09-F4	Fiberglass Base Station	RPSMA	4.1 dBi	-	Fixed
A09-F5	Fiberglass Base Station	RPSMA	5.1 dBi	-	Fixed
A09-F6	Fiberglass Base Station	RPSMA	6.1 dBi	- 0.1 dB*	Fixed
A09-F7	Fiberglass Base Station	RPSMA	7.1 dBi	- 1.1 dB*	Fixed
A09-F8	Fiberglass Base Station	RPSMA	8.1 dBi	- 2.1 dB*	Fixed
A09-W7SM	Wire Base Station	RPSMA	7.1 dBi	- 1.1 dB*	Fixed
A09-F0TM	Fiberglass Base Station	RPTNC	0 dBi	-	Fixed
A09-F1TM	Fiberglass Base Station	RPTNC	1.0 dBi	-	Fixed
A09-F2TM	Fiberglass Base Station	RPTNC	2.1 dBi	-	Fixed
A09-F3TM	Fiberglass Base Station	RPTNC	3.1 dBi	-	Fixed
A09-F4TM	Fiberglass Base Station	RPTNC	4.1 dBi	-	Fixed
A09-F5TM	Fiberglass Base Station	RPTNC	5.1 dBi	-	Fixed
A09-F6TM	Fiberglass Base Station	RPTNC	6.1 dBi	- 0.1 dB*	Fixed
A09-F7TM	Fiberglass Base Station	RPTNC	7.1 dBi	- 1.1 dB*	Fixed
A09-F8TM	Fiberglass Base Station	RPTNC	8.1 dBi	- 2.1 dB*	Fixed
A09-W7TM	Wire Base Station	RPTNC	7.1 dBi	- 1.1 dB*	Fixed

Table A.4. Mag Mount antennas (approved when operating at 1 Watt power output or lower.)

Part Number	Type	Connector	Gain	Required Antenna Cable Loss	Application
A09-M0SM	Mag Mount	RPSMA	0 dBi	-	Fixed
A09-M2SM	Mag Mount	RPSMA	2.1 dBi	-	Fixed
A09-M3SM	Mag Mount	RPSMA	3.1 dBi	-	Fixed
A09-M5SM	Mag Mount	RPSMA	5.1 dBi	-	Fixed
A09-M7SM	Mag Mount	RPSMA	7.1 dBi	-1.1 dB*	Fixed
A09-M8SM	Mag Mount	RPSMA	8.1 dBi	-2.1 dB*	Fixed
A09-M0TM	Mag Mount	RPTNC	0 dBi	-	Fixed
A09-M2TM	Mag Mount	RPTNC	2.1 dBi	-	Fixed
A09-M3TM	Mag Mount	RPTNC	3.1 dBi	-	Fixed
A09-M5TM	Mag Mount	RPTNC	5.1 dBi	-	Fixed
A09-M7TM	Mag Mount	RPTNC	7.1 dBi	-1.1 dB*	Fixed
A09-M8TM	Mag Mount	RPTNC	8.1 dBi	-2.1 dB*	Fixed

Table A.5. Multi-path antennas (approved when operating at 1 Watt power output or lower.)

Part Number	Type	Connector	Gain	Application
A09-DPSM-P12F	omni directional permanent mount w/ 12ft pigtail	RPSMA	3.0 dBi	Fixed
A09-D3NF-P12F	omni directional magnetic mount w/ 12ft pigtail	RPN	3.0 dBi	Fixed
A09-D3SM-P12F	omni directional w/ 12ft pigtail	RPSMA	3.0 dBi	Fixed
A09-D3PNF	omni directional permanent mount	RPN	3.0 dBi	Fixed
A09-D3TM-P12F	omni directional w/ 12ft pigtail	RPTNC	3.0 dBi	Fixed
A09-D3PTM	omni directional permanent mount	RPTNC	3.0 dBi	Fixed
A92-D4PNF	900 MHz / 2.4GHz permanent mount	RPN	2.1 dBi	Fixed
A92-D4P	900 MHz / 2.4GHz permanent mount	RPSMA	2.1 dBi	Fixed
A92-D4PTM	900 MHz / 2.4GHz permanent mount	RPTNC	2.1 dBi	Fixed

* FCC regulations stipulate a 36 dBm EIRP power requirement. Users implementing antenna gain greater than 6.0 dB must compensate for the added gain with cable loss. When operating at 1 W power output, the sum (in dB) of cable loss and antenna gain shall not exceed 6.0 dB.

100 milliWatt Transmit Power Output or Lower**Table A.6. Monopole antennas** (approved when operating at 100 mW power output or lower.)

Part Number	Type	Connector	Gain	Application
A09-QW	Quarter-wave wire	Permanent	1.9 dBi	Fixed / Mobile
A09-QRAMM	3 " Quarter-wave wire	MMCX	2.1 dBi	Fixed / Mobile
A09-QSM-3	Quarter-wave straight	RPSMA	1.9 dBi	Fixed / Mobile
A09-QSM-3H	Heavy duty quarter-wave straight	RPSMA	1.9 dBi	Fixed / Mobile
A09-QBMM-P6I	Quarter-wave w/ 6" pigtail	MMCX	1.9 dBi	Fixed / Mobile
A09-QHRN	Miniature Helical Right Angle solder	Permanent	-1 dBi	Fixed / Mobile
A09-QHSN	Miniature Helical Right Angle solder	Permanent	-1 dBi	Fixed / Mobile
A09-QHSM-2	2" Straight	RPSMA	1.9 dBi	Fixed / Mobile
A09-QHRSM-2	2" Right angle	RPSMA	1.9 dBi	Fixed / Mobile
A09-QHRSM-170	1.7" Right angle	RPSMA	1.9 dBi	Fixed / Mobile
A09-QRSM-380	3.8" Right angle	RPSMA	1.9 dBi	Fixed / Mobile
A09-QAPM-520	5.2" Articulated Screw mount	Permanent	1.9 dBi	Fixed / Mobile
A09-QSPM-3	3" Straight screw mount	Permanent	1.9 dBi	Fixed / Mobile
A09-QAPM-3	3" Articulated screw mount	Permanent	1.9 dBi	Fixed / Mobile
A09-QAPM-3H	3" Articulated screw mount	Permanent	1.9 dBi	Fixed / Mobile

Table A.7. Yagi antennas (approved when operating at 100 mW power output or lower.)

Part Number	Type	Connector	Gain	Application
A09-Y6	2 Element Yagi	RPN	6.1 dBi	Fixed / Mobile
A09-Y7	3 Element Yagi	RPN	7.1 dBi	Fixed / Mobile
A09-Y8	4 Element Yagi	RPN	8.1 dBi	Fixed / Mobile
A09-Y9	4 Element Yagi	RPN	9.1 dBi	Fixed / Mobile
A09-Y10	5 Element Yagi	RPN	10.1 dBi	Fixed / Mobile
A09-Y11	6 Element Yagi	RPN	11.1 dBi	Fixed / Mobile
A09-Y12	7 Element Yagi	RPN	12.1 dBi	Fixed / Mobile
A09-Y13	9 Element Yagi	RPN	13.1 dBi	Fixed / Mobile
A09-Y14	10 Element Yagi	RPN	14.1 dBi	Fixed / Mobile
A09-Y14	12 Element Yagi	RPN	14.1 dBi	Fixed / Mobile
A09-Y15	13 Element Yagi	RPN	15.1 dBi	Fixed / Mobile
A09-Y15	15 Element Yagi	RPN	15.1 dBi	Fixed / Mobile
A09-Y6TM	2 Element Yagi	RPTNC	6.1 dBi	Fixed / Mobile
A09-Y7TM	3 Element Yagi	RPTNC	7.1 dBi	Fixed / Mobile
A09-Y8TM	4 Element Yagi	RPTNC	8.1 dBi	Fixed / Mobile
A09-Y9TM	4 Element Yagi	RPTNC	9.1 dBi	Fixed / Mobile
A09-Y10TM	5 Element Yagi	RPTNC	10.1 dBi	Fixed / Mobile
A09-Y11TM	6 Element Yagi	RPTNC	11.1 dBi	Fixed / Mobile
A09-Y12TM	7 Element Yagi	RPTNC	12.1 dBi	Fixed / Mobile
A09-Y13TM	9 Element Yagi	RPTNC	13.1 dBi	Fixed / Mobile
A09-Y14TM	10 Element Yagi	RPTNC	14.1 dBi	Fixed / Mobile
A09-Y14TM	12 Element Yagi	RPTNC	14.1 dBi	Fixed / Mobile
A09-Y15TM	13 Element Yagi	RPTNC	15.1 dBi	Fixed / Mobile
A09-Y15TM	15 Element Yagi	RPTNC	15.1 dBi	Fixed / Mobile

IC (Industry Canada) Certification

Labeling requirements for Industry Canada are similar to those of the FCC. A clearly visible label on the outside of the final product enclosure must display the following text:

Contains Model 9XTend Radio, IC: 4214A-9XTEND

Integrator is responsible for its product to comply with IC ICES-003 & FCC Part 15, Sub. B - Unintentional Radiators. ICES-003 is the same as FCC Part 15 Sub. B and Industry Canada accepts FCC test report or CISPR 22 test report for compliance with ICES-003.

Appendix B: Additional Information

1 Year Warranty

AWB-S RF Modems (the "Product") are warranted against defects in materials and workmanship under normal use, for a period of 1-year from the date of purchase. In the event of a product failure due to materials or workmanship, the manufacturer will repair or replace the defective product. For warranty service, return the defective product to the manufacturer, shipping prepaid, for prompt repair or replacement.

The foregoing sets forth the full extent of manufacturer warranties regarding the Product. Repair or replacement at the manufacturer's option is the exclusive remedy. THIS WARRANTY IS GIVEN IN LIEU OF ALL OTHER WARRANTIES, EXPRESS OR IMPLIED, AND THE MANUFACTURER SPECIFICALLY DISCLAIMS ALL WARRANTIES OF MERCHANTABILITY OR FITNESS FOR A PARTICULAR PURPOSE. IN NO EVENT SHALL THE MANUFACTURER, ITS SUPPLIERS OR LICENSORS BE LIABLE FOR DAMAGES IN EXCESS OF THE PURCHASE PRICE OF THE PRODUCT, FOR ANY LOSS OF USE, LOSS OF TIME, INCONVENIENCE, COMMERCIAL LOSS, LOST PROFITS OR SAVINGS, OR OTHER INCIDENTAL, SPECIAL OR CONSEQUENTIAL DAMAGES ARISING OUT OF THE USE OR INABILITY TO USE THE PRODUCT, TO THE FULL EXTENT SUCH MAY BE DISCLAIMED BY LAW. SOME STATES DO NOT ALLOW THE EXCLUSION OR LIMITATION OF INCIDENTAL OR CONSEQUENTIAL DAMAGES. THEREFOR, THE FOREGOING EXCLUSIONS MAY NOT APPLY IN ALL CASES. This warranty provides specific legal rights. Other rights which vary from state to state may also apply.

Contact Adalet Wireless

Free and unlimited technical support is included with every Adalet Wireless Radio Modem sold.

Please use the following resources for additional support:

Documentation:	www.adaletwireless.com	
Technical Support:	Phone.	216-267-6864
	E-Mail.	info@adaletwireless.com

Adalet Wireless office hours are 8:00 am – 5:00 pm [U.S. Eastern Standard Time]