

Z-14

1:14 CONTINUOUS ZOOM VIDEO SYSTEM



Motic Z-14 Video Zoom Microscope

The Motic Z-14 combines the best of an optical stereomicroscope 1 : 14 optical zoom with the best of a video based system auto focus in one system for video inspection and observation, simple measurement, and specimen cataloguing. Whether integrated with the numerous accessories or simply used by itself, the Z-14 is a user-friendly solution to unfriendly environments.

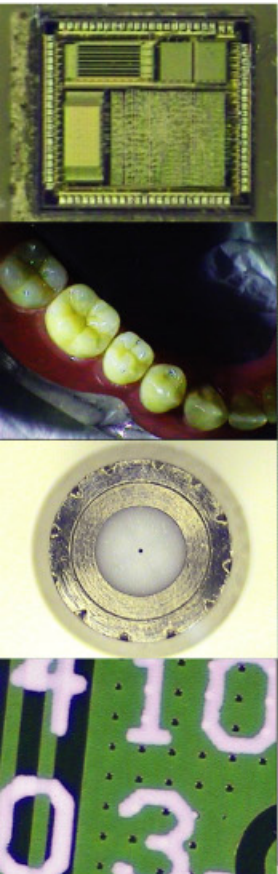

Standard System

The standard system consists of six parts: (1) Zoom Assembly, (2) Objective, (3) Stand, (4) Control box, (5) Hand Remote, and (6) Motic Images Plus 2.0 ML software, which are combined to complement each other to produce a user-friendly instrument. Equipped standard with a 172mm (0.5X objective) working distance and an optical zoom ratio of 1 : 14, the Z-14 can be used in numerous tasks ranging from large sample inspection to micro welding small parts assembly or routine inspection.

The Zoom Assembly outputs >480 lines of resolution to lessen the strain on the user's eyes when viewing small or complicated samples. To avoid the troublesome task of aligning the camera sensor to the method of viewing, the Zoom Assembly has an alignment sticker that when aligned properly with a similar sticker on the head holder the sensor will be in the correct position for the user's viewing. This alignment further guarantees the perpendicular viewing of the camera sensor.

Since the standard system is similar to a regular stereomicroscope setup, space consumption is kept to a minimum. Moreover, keeping the same principle of a stereomicroscope, the Z-14's standard system is easily expandable with numerous accessories to meet any requirement of the task.

Hand Remote

When the Z-14 is used in the standard package, the hand remote controls the magnification of the system. In addition to controlling the magnification, the hand remote manipulates the focus, brightness, and operation of the overall system. The hand remote derives its power from the control box via its 1.5m cable connection.

A. DISPLAY SCREEN

When the hand remote is switched on, the display screen will show the user the magnification the system is operating at along with focus and brightness control.

B. ZOOM

- The ZOOM controls the whole number magnification change of the Zoom Assembly from 1X to 14X similar to a step magnification system. When using the ZOOM control, the magnification appears in the upper right hand corner of the display screen.

C. FINE ZOOM

- Unlike the ZOOM control, the FINE ZOOM controls a continuous zoom through the 1X - 14X magnification range of the system similar to a zoom stereomicroscope. The image output is continuously in focus throughout the zoom. The value is displayed in two parts by the whole number value on the lower left hand side and the scale bar approximation of the decimal value.

D. FOCUS

- The FOCUS control is activated by pressing the FOCUS AUTO/M to switch the system from its factory default of AUTO (A) to MANUAL (M). Once switched to MANUAL, the FOCUS control adjusts the focal plane of the system, which is helpful for samples with numerous layers. The images below demonstrate the different focal planes. The image on the left is the system's default auto focus image, whereas the image on the right is the manually adjusted focus.

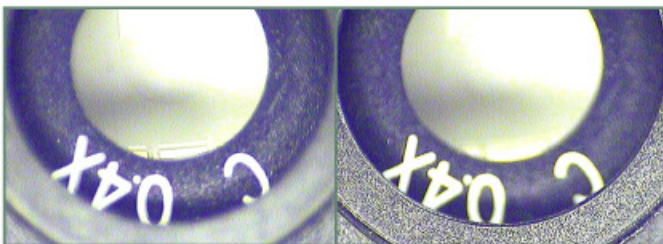

E. BRT Default focus Manual focus

- BRT is short for Brightness. The BRT controls the system's brightness control to correct the absorption of illumination by the Zoom Assembly to produce the best image.

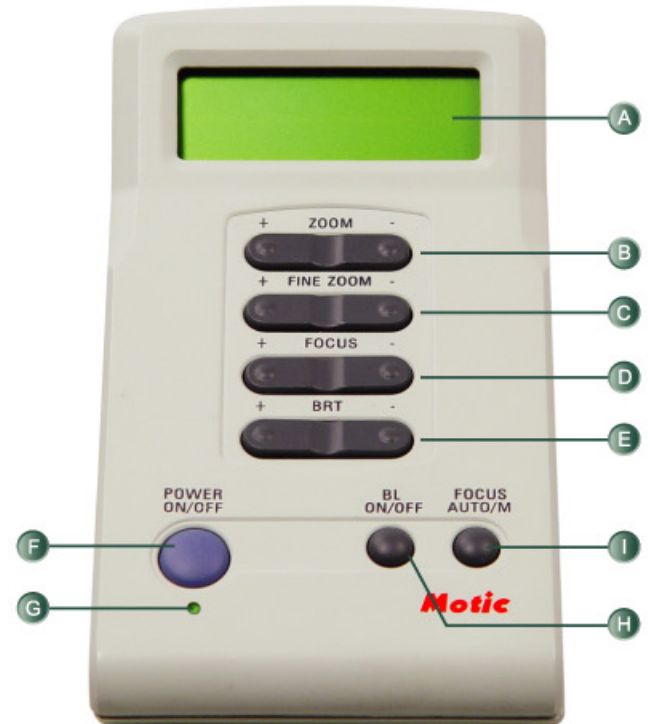

Button Functions

F. POWER ON/OFF

Turns the overall Z-14 system ON or OFF. ON is indicated by an illuminated Green LED.

G. LED

Indicates whether the system is ON or OFF.

H. BL ON/OFF

BL is the abbreviation for BACKLIGHT. By pressing this button, the Zoom Assembly adds a back light effect to the image output for smoothing out the overall image. When activated, a "B" appears in the upper right hand corner of the hand remote.

I. FOCUS AUTO/M

Pressing this button switches off the Z-14's Auto Focus system and activates the FOCUS Control.

Control Box



The control box of the Z-14 system is the actual brains of the operation; converting and directing the zoom assembly while outputting the visual information to 3-simultaneous outputs (S-Video, RCA, and USB 2.0). The control box is conveniently equipped standard with a universal power supply input.

Motic Images Plus 2.0 ML

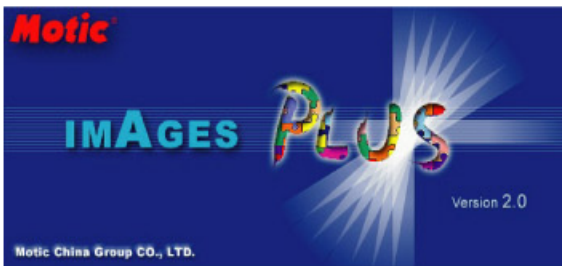

The Motic Images Plus 2.0 ML software is the capture and analysis interface for the Z-14 system. A simple, yet powerful software providing a majority of the functions found in sophisticated softwares, Images Plus is the ideal complement to the Z-14 system. The user of the Z-14 system with the Images Plus software has the ability to document, catalogue, and conduct manual measurements.

Capture Window

The observation and capture interface of the Images Plus software when used with the Z-14 offers the opportunity to adjust the image's contrast, brightness, and hue to present the optimum image to capture or to make an instant decision of the quality status of the sample. Thinking of convenience, the capture window has the icons for Capture, Time delayed capture, and video recording located on the left side of the window for easy selection. Therefore, the Z-14 can easily capture one frame or multiple frames or a video of the sample to match the requirements of the applications.

Cataloguing

The Z-14 system is an instant cataloguing system once the system is operated with the Motic Images Plus 2.0 ML software. The software automatically saves all capture images to a file marked with the date of operation to assist with any accidental deletions and/or forgotten savings. The user is able to designate specific files locations with the software's Album function to organize the cataloguing of images. Images Plus also allows the capture image to be export to other designated files in a specified file format (i.e. tiff or jpg).

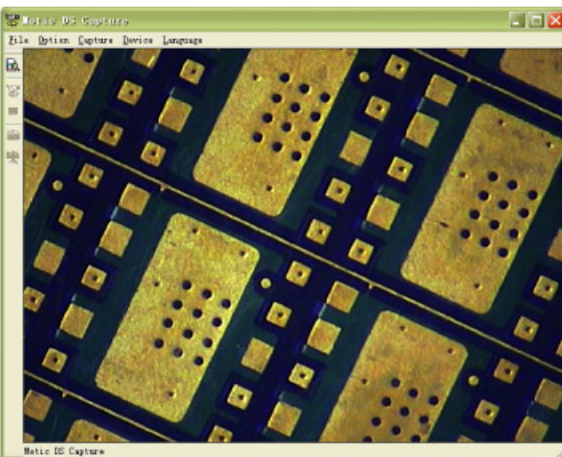

Capture Window

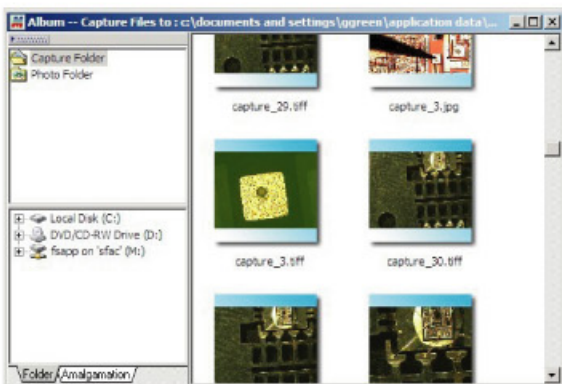

Catalogue folder options

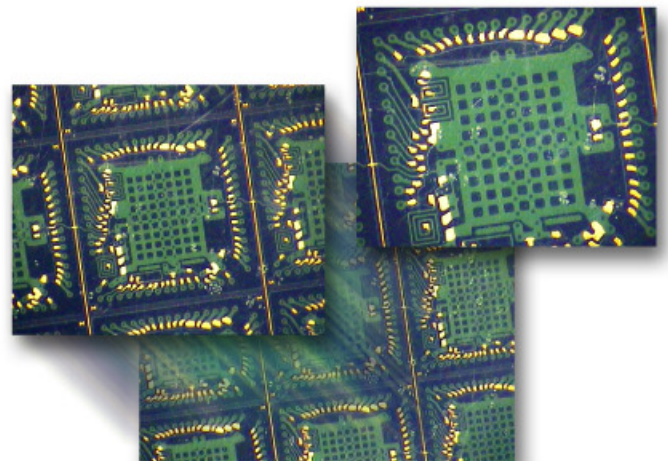

Manual Measurement

Inside the Images Plus software, the user has nine manual measurement options to select from. Ranging from the simple line to 3 point circles to irregular shape formats, there is a measurement type for each application. When a measurement is conducted, the software displays an instant result on the image showing the findings in the measurement units requested. These instant displays can be saved into the image for rapid sharing or quick reference. Furthermore, all measurements are displayed in a Measurement Table, which is exportable to an EXCEL format for further convenience when sharing with others.

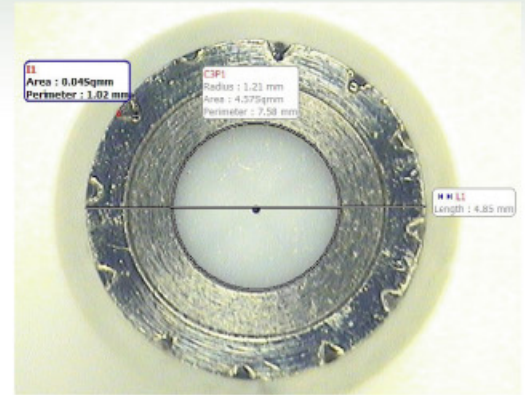

Manual Measurement
(line, 3-point circle, and irregular)

Calibration

As the Images Plus software permits a user to conduct manual measurements of the captured image, the system's proper calibration is highly important. All Z-14 systems come with a standard calibration dot designed specifically for Z-14 to ensure the highest accuracy of measurements.

Calibrating the system is a simple and easy process helped along by the software calibration wizard's simple steps. Capture the calibration dot. Open the calibration wizard. Load the image. Input the magnification value and size of the calibration dot. Click calibrate. The software will display a calibration table and permit the user to name the calibration in order to return to it [repeatability].

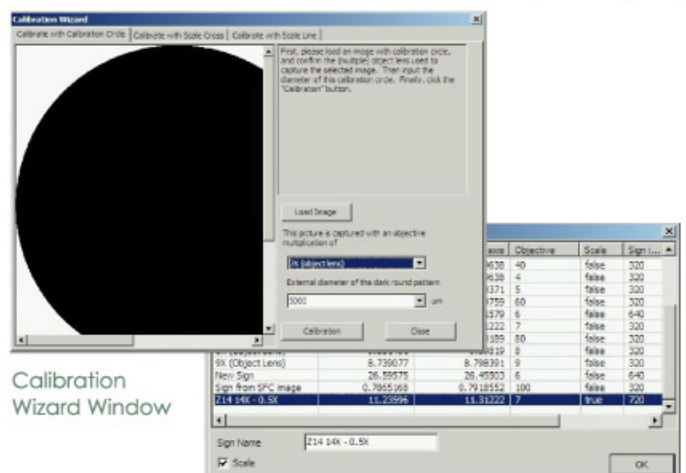

Calibration
Wizard Window

Calibration Table

Basic Auto Segmentation

In addition to manual measurement, Images Plus permits the user to perform some basic auto segmentation. Using one of the six specialised ROIs options, the user can define the section of the sample for the software to perform the auto segmentation before continuing onto the auto calculation.

Once the auto calculation is completed, the data gathered by the software is presented in a separate window. All the information is capable of being export into a text (.txt) or EXCEL (.xls) format for documentation.



Auto Segmentation

Image Comparison

The image comparison function inside the Image Plus software brings the element of side by side comparison to the Z-14. Instantly see if that sample is acceptable. Find out what is the difference between two different illumination sources (see image on the left) being used on a product. Observe how fast a sample is contaminated. All are possible with the Z-14 with the Motic Images Plus 2.0 ML software.

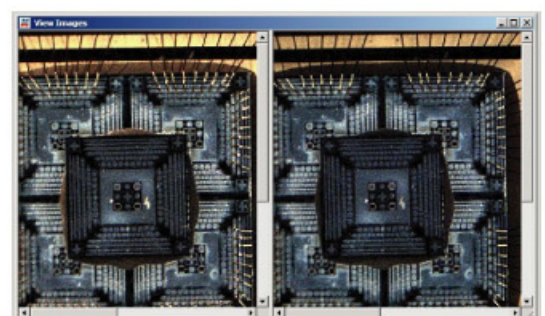

Image Comparison -
Same sample, different illumination sources

ACCESSORIES

Z-14

System Accessories



Z-14 Foot Pedal



1.0X objective

Foot Pedal

Available as an option is the foot pedal zoom control for the Z-14. With the foot pedal, the operator is able to utilise both hands for manipulating the sample while controlling the FINE continuous zoom function with the feet. The foot pedal is equipped with a 2m length cable, which attaches to the control box, for adequate length for most application set ups.

Auxiliary Objective

For some applications, extra magnification is needed to bring that last bit of information to the forefront. The available 1.0X objective permits the Z-14 to produce up to a 60X magnification (1024 x 768 display ratio, 19" monitor) with a working distance of 75mm.

Illumination

Not all environments are going to provide sufficient lux output nor will all applications be completed with the 1 lux sensitivity of the Z-14. Therefore, Motic provides two illumination options to assist the Z-14 without compromising its ability to focus and perform the necessary task.

2401K Fluorescent ring light

The 2401K provides a 6400K of shadow and flicker free illumination uniformly over the sample. Easily attachable to the objective bottom, the 2401K is the ideal economic solution for additional illumination.

Fiber optic ring light

Should the application require the power source away from the sample to prevent heat contamination of the sample, the MLC-150 fiber optic illuminator and fiber optic ring light are the ideal option. The 1.5m length of the fiber optic cable along with the 2m long remote control for intensity adjustment permit the user to place the illuminator away from the sample. The output is a cool, even, 3200K colour temperature illumination with intensity control to prevent over saturation.



Z-14 with 2401K fluorescent ring light

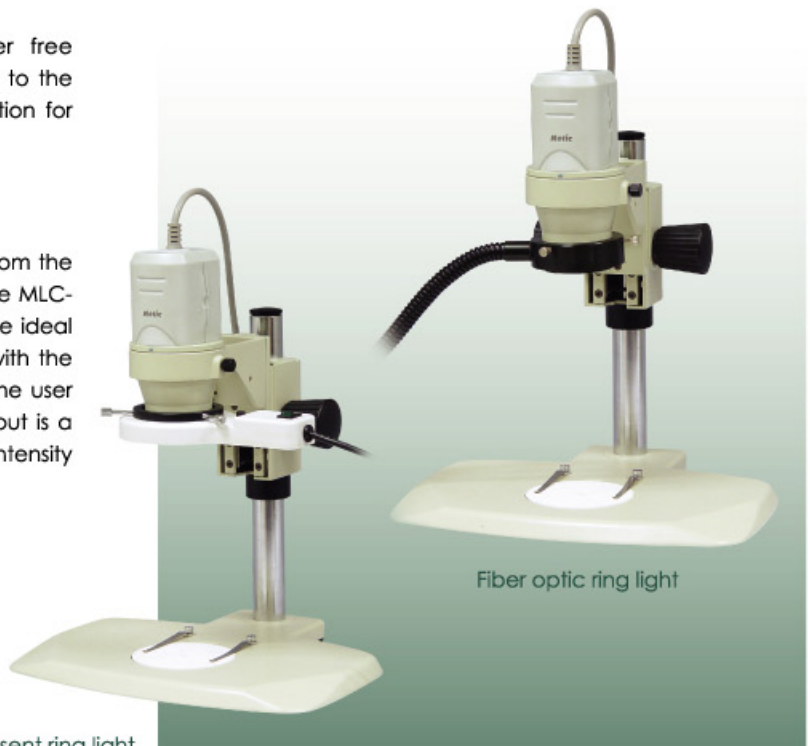

Fiber optic ring light

Stands and stages

Similar to illumination, the size of the sample will not always be uniform with the basic package. The Z-14 can be adapted to different stands and stages for better overall working distance, working area, and/or focus control to continuously expand to meet the challenge of the inspection and/or observation.

Manual movement stand

Certain applications require a larger working area with the ability to move the sample. The manual movement stand provides a 400mm x 350mm working surface with individual lockable X- and Y-axis movements. An ideal choice for large samples or the observation of multiple samples without constantly removing the samples.



Manual movement stand system

Fixed mount stand

With the focus mechanism and stand built into one system, the Z-14 is guaranteed perfect perpendicular observation of the sample. Easily integrated with either the 2401K fluorescent ring light or the MLC-150 with fiber optic ring light guide illumination, the fixed mount stand is the perfect stand for conducting observations where the highest amount of detail is needed.



Z-14 with fixed mount stand

Mechanical stage

Attachable to the basic stand of the Z-14 along with the fixed mount stand, the mechanical stage is a convenient attachment for easy movements. The stage has a 75mm (X) x 50mm (Y) movement that one's hand cannot provide.



Mechanical Stage



OPTICAL DATA

Z-14

Z-14 System Magnification Ratio

800 x 600 Display Format

Monitor	10.4" Monitor		15" Monitor		17" Monitor		19" Monitor	
	0.5X	1.0X	0.5X	1.0X	0.5X	1.0X	0.5X	1.0X
1X	1.9	3.8	2.7	5.4	3.1	6.1	3.4	6.9
2X	3.8	7.5	5.4	10.8	6.1	12.3	6.9	13.7
3X	5.6	11.3	8.1	16.2	9.2	18.4	10.3	20.6
4X	7.5	15.0	10.8	21.6	12.3	24.5	13.7	27.4
5X	9.4	18.8	13.5	27.1	15.3	30.7	17.1	34.3
6X	11.3	22.5	16.2	32.5	18.4	36.8	20.6	41.1
7X	13.1	26.3	18.9	37.9	21.5	42.9	24.0	48.0
8X	15.0	30.0	21.6	43.3	24.5	49.1	27.4	54.8
9X	16.9	33.8	24.4	48.7	27.6	55.2	30.8	61.7
10X	18.8	37.5	27.1	54.1	30.7	61.3	34.3	68.5
11X	20.6	41.3	29.8	59.5	33.7	67.5	37.7	75.4
12X	22.5	45.0	32.5	64.9	36.8	73.6	41.1	82.3
13X	24.4	48.8	35.2	70.4	39.9	79.7	44.6	89.1
14X	26.3	52.5	37.9	75.8	42.9	85.9	48.0	96.0

1024 x 768 Display Format

Monitor	10.4" Monitor		15" Monitor		17" Monitor		19" Monitor	
	0.5X	1.0X	0.5X	1.0X	0.5X	1.0X	0.5X	1.0X
1X	1.2	2.3	1.7	3.4	1.9	3.8	2.1	4.3
2X	2.3	4.7	3.4	6.8	3.8	7.7	4.3	8.6
3X	3.5	7.0	5.1	10.1	5.8	11.5	6.4	12.9
4X	4.7	9.4	6.8	13.5	7.7	15.3	8.6	17.1
5X	5.9	11.7	8.5	16.9	9.6	19.2	10.7	21.4
6X	7.0	14.1	10.1	20.3	11.5	23.0	12.9	25.7
7X	8.2	16.4	11.8	23.7	13.4	26.8	15.0	30.0
8X	9.4	18.8	13.5	27.1	15.3	30.7	17.1	34.3
9X	10.6	21.1	15.2	30.4	17.3	34.5	19.3	38.6
10X	11.7	23.5	16.9	33.8	19.2	38.3	21.4	42.8
11X	12.9	25.8	18.6	37.2	21.1	42.2	23.6	47.1
12X	14.1	28.1	20.3	40.6	23.0	46.0	25.7	51.4
13X	15.2	30.5	22.0	44.0	24.9	49.8	27.8	55.7
14X	16.4	32.8	23.7	47.4	26.8	53.7	30.0	60.0

Z14 System Object Field

Magn.	0.5X Obj	1X Obj
	l x w (mm)	l x w (mm)
1X	110.0 x 80.3	55.0 x 40.2
2X	55.0 x 40.2	27.5 x 20.1
3X	36.7 x 26.8	18.3 x 13.4
4X	27.5 x 20.1	13.8 x 10.0
5X	22.0 x 16.1	11.0 x 8.0
6X	18.3 x 13.4	9.2 x 6.7
7X	15.7 x 11.5	7.9 x 5.7
8X	13.8 x 10.0	6.9 x 5.0
9X	12.2 x 8.9	6.1 x 4.5
10X	11.0 x 8.0	5.5 x 4.0
11X	10.0 x 7.3	5.0 x 3.7
12X	9.2 x 6.7	4.6 x 3.3
13X	8.5 x 6.2	4.2 x 3.1
14X	7.9 x 5.7	3.9 x 2.9

Z14 System Depth of Focus

Standard Objective	0.5X with magnification range 1X-14X (0.5X-7X)
1X	16 grid / 8mm
7X	4 grid/2mm
14X	1.25 grid/0.625mm
Auxiliary Objective	1.0X with magnification range: 1X-14X (1X-14X)
1X	16 grid/8mm
7X	1 grid/0.5mm
14X	0.6 grid/0.3mm



205 Westwood Ave, Long Branch, NJ 07740
 Phone: 866-94 BOARDS (26273) / (732)-222-1511
 Fax: (732)-222-7088 | E-mail: sales@touchboards.com

Specifications

Purpose	Video inspection and observation, Simple measurement, Specimen cataloging	
Zoom Body	Standard Magnification	1.7X - 23.7X (0.5X Objective, 15" monitor, 1024 x 768 Display Format)
	Zoom Ratio	1:14
	Standard Object Field	110.0mm x 80.3mm - 7.9mm x 5.7mm
	Standard Working Distance	172mm (0.5X Objective)
	Magnification Controls	Step and fine zoom via hand remote
	Optional Magnification	3.4X - 47.7X (1.0X Objective, 15" monitor, 1024 x 768 Display Format)
	Optional Object Field	55.0mm x 40.2mm - 3.9mm x 2.9mm
	Optional Working Distance	75mm (1.0X Objective)
	Optional Magnification Controls	Fine zoom via foot pedal Fine and step zoom via computer
Camera	Sensor	1/4" Built-in
	Maximum Pixels	795 x 596 [470K]
	Effective Pixels	752 x 582 [440K]
	Recognition	>480 lines
	Output	USB2.0, Composite, S-Video [simultaneous]
	System	PAL/NTSC
	Scanning Frequency	15.625 Khz [horizontal], 50Khz [vertical]
	White Balance	Auto
	Sensitivity	1 lux
Hand Remote	Zoom Movements	Step and fine
	Focus Control	Switch between Auto and Manual; control manual focus
	Brightness Control	Manual controls brightness positive and negative
Capture Card	Function	Capture and measure
	Supports RGB	32, 24, 12
	Input Signal	S-Video and RCA
	Output Signal	S-Video
	Maximum Capture Window	640 x 480
	Supported Systems	NTSC/PAL
Software	Standard Software	Motic Images Plus 2.0 ML (Multi-language)
	Functions	Manual measurements; Image filters; Auto Segmentation; Cataloguing
Stand	Standard Stand	2112: Incident large working area stand
	Focus Travel	48mm
	Head Mount	74mm
Power	Input Voltage	90V-240V Universal Power Supply
Dimensions	System Only	363mm(h) x 330mm(w) x 280mm(d)
	Shipping Dimensions	460mm(h) x 400mm(w) x 400mm(d)

SYSTEM DIAGRAM Z-14

Full System Diagram

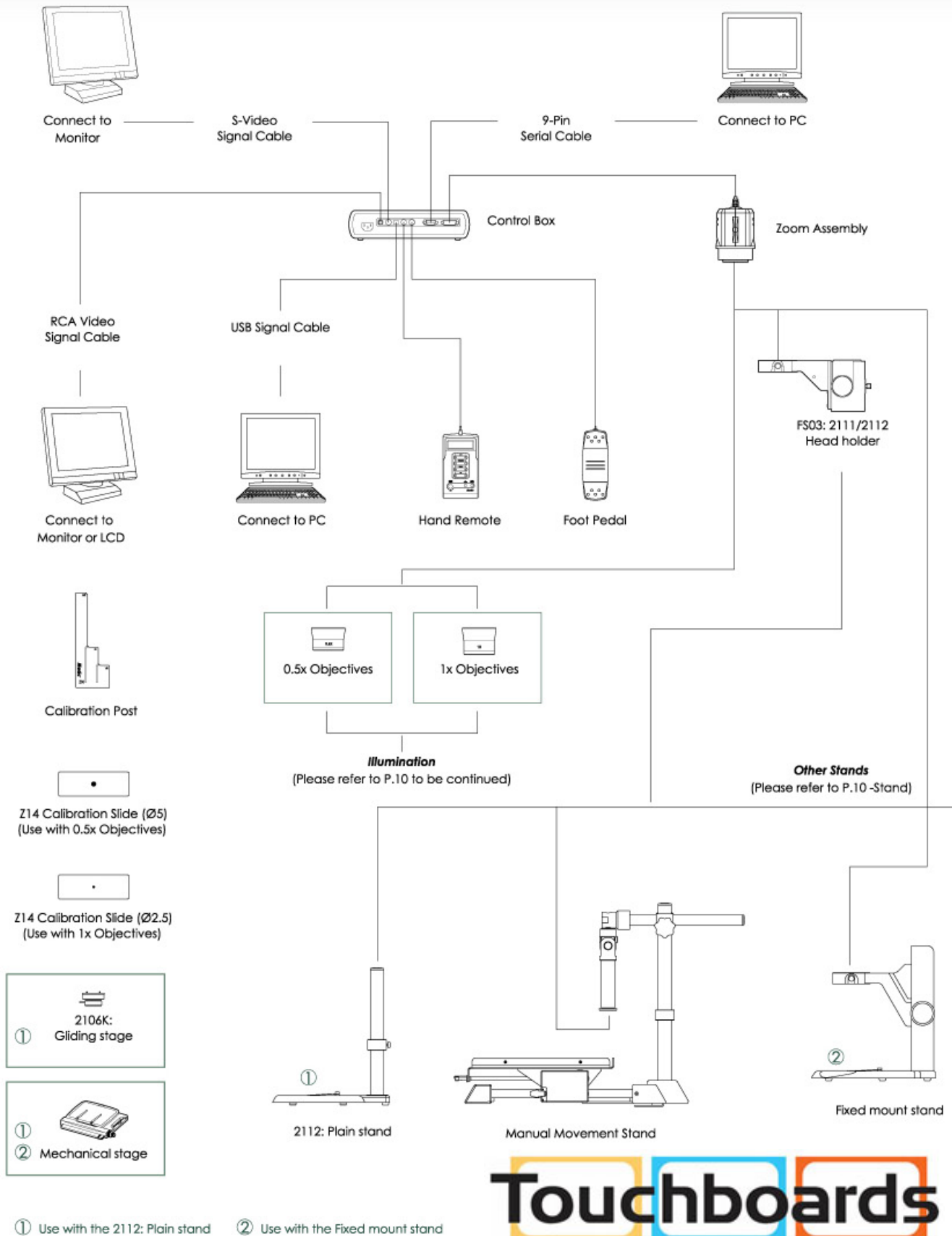

Touchboards

205 Westwood Ave, Long Branch, NJ 07740
 Phone: 866-94 BOARDS (26273) / (732)-222-1511
 Fax: (732)-222-7088 | E-mail: sales@touchboards.com

illumination

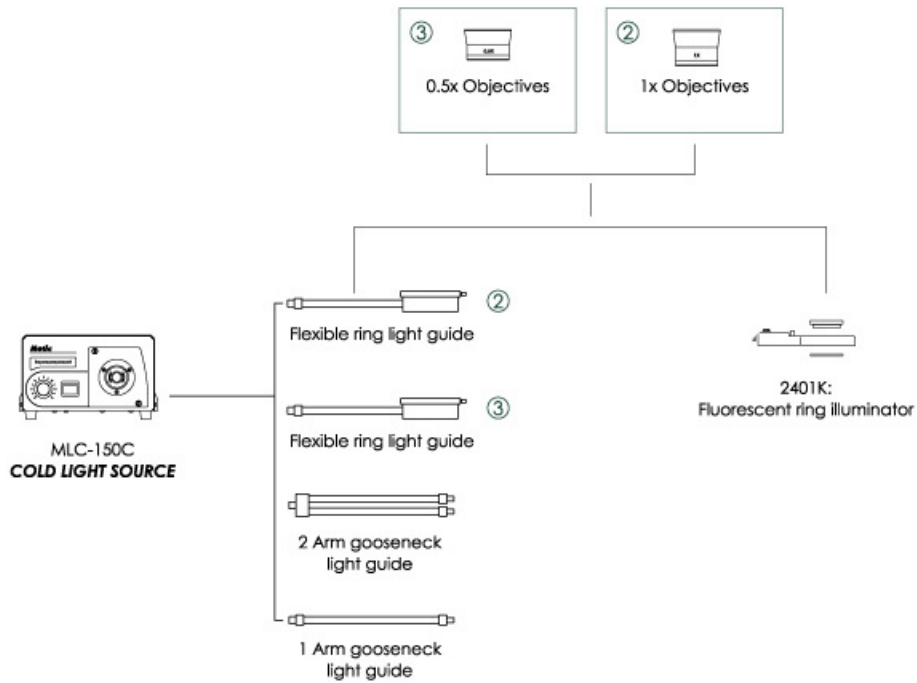

- ② Not suitable for 1X Objective
- ③ Not suitable for 0.5X Objective

Stand

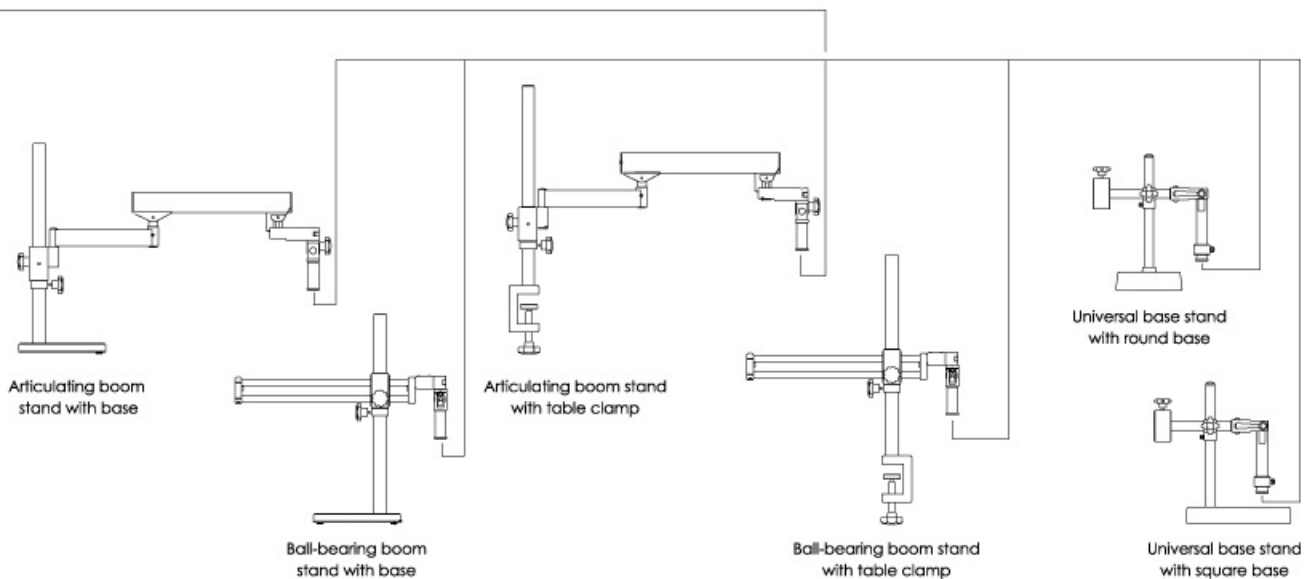

Z14 Schematic Diagram [Plain Stand]

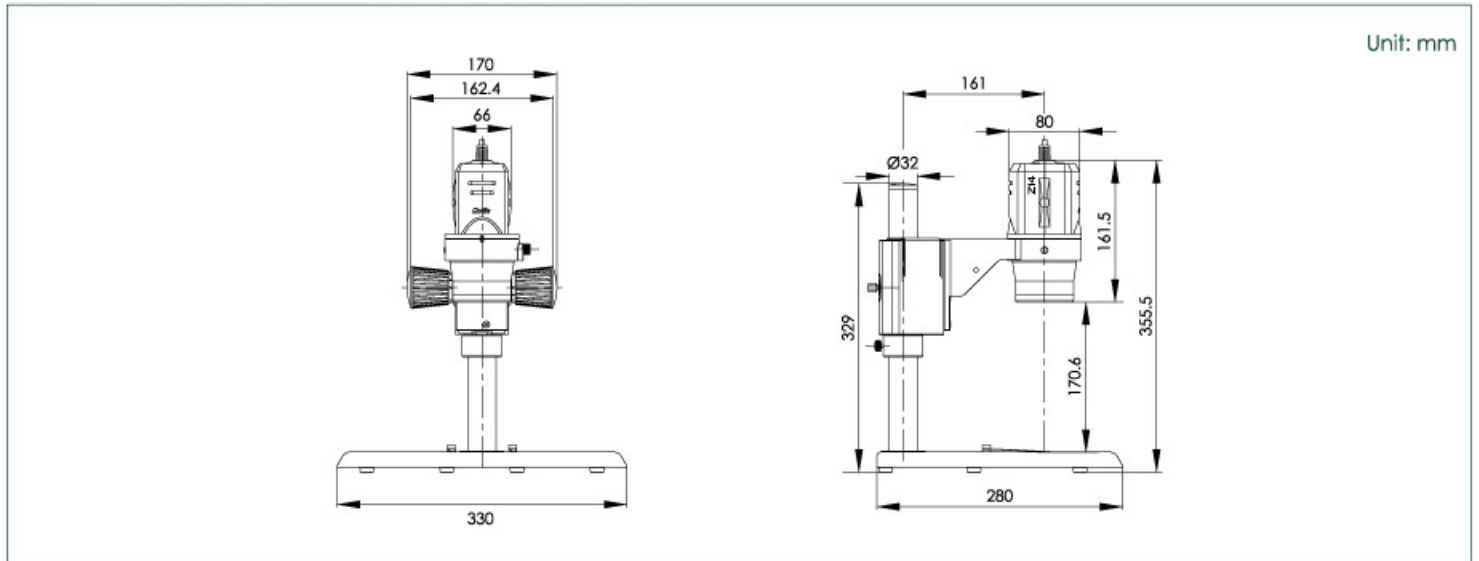

Z14 Schematic Diagram [Manual Movement Stand]

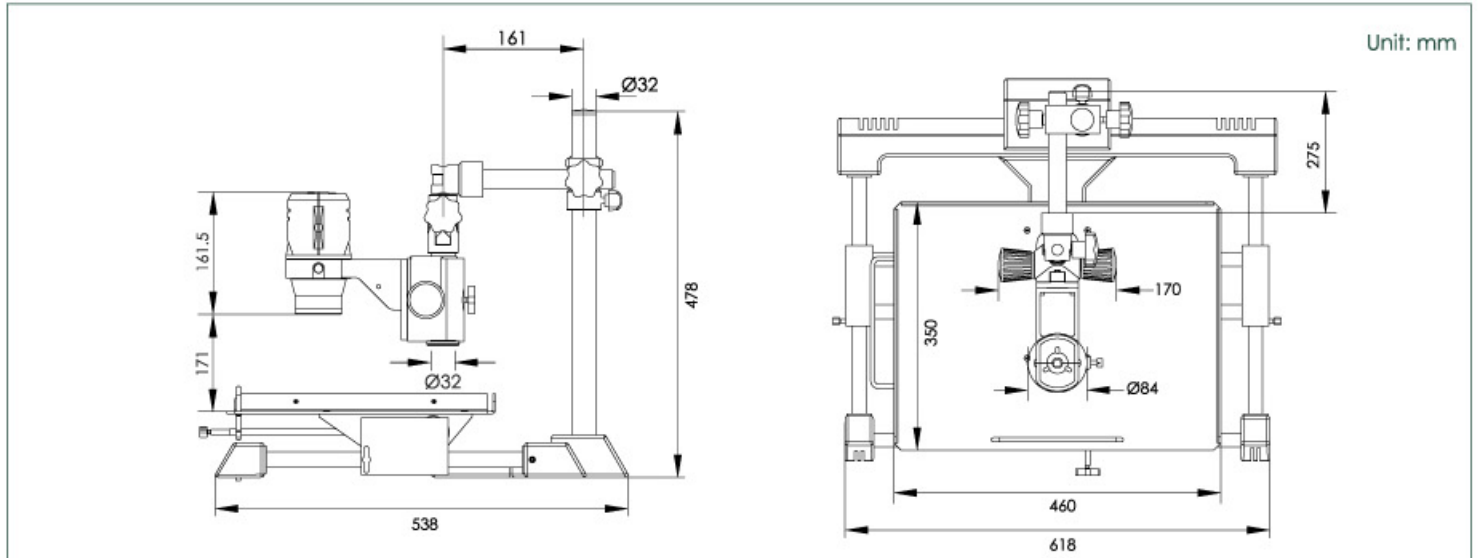

Motic®

More Than Microscopy

Motic Incorporation Ltd. (HONG KONG)

Rm 2907-8, Windsor House, 311 Gloucester Road, Causeway Bay, Hong Kong
Tel: 852-2837 0888 Fax: 852-2882 2792

Motic Instruments Inc. (CANADA)

180-4320 Viking Way Richmond, B.C. V6V 2L4 Canada
Tel: 1-877-977 4717 Fax: 1-604-303 9043

Motic Deutschland GmbH (GERMANY)

Gewerbepark Spilburg, Spilburgstrasse 1 D-35578 Wetzlar Germany
Tel: 49-6441-210 010 Fax: 49-6441-210 0122

Motic Spain, S.L. (SPAIN)

Polígono Industrial Les Corts, Camí del Mig, 112 08349 Cabrera de Mar, Barcelona Spain
Tel: 34-93-756 6286 Fax 34-93-756 6287

For Inquiries in UK (UK)

Saracens House, 25 St. Margarets Green, Ipswich, IP4 2BN, Suffolk, UK
Tel: 44-(0)-14732 81909 Fax: 44-(0)-14732 11508

Motic Incorporation Limited Copyright © 2002-2007. All Rights Reserved.

Design Change : The manufacturer reserves the right to make changes in instrument design in accordance with scientific and mechanical progress, without notice and without obligation.

Touchboards

205 Westwood Ave, Long Branch, NJ 07740
Phone: 866-94 BOARDS (26273) / (732)-222-1511
Fax: (732)-222-7088 | E-mail: sales@touchboards.com

Motic Certified ISO 9001
Certified ISO 14001

Code: 1300901301922