



Explorer[®] Pro

Electronic Balances



The OHAUS Explorer[®] Pro Series, the new standard for performance and value in laboratory balances!

The OHAUS Explorer[®] Pro Series of standard level balances was designed for simplicity and includes the industry's easiest user interface for effortless setup and operation; no training is required. The Explorer Pro offers all the features and durability found in high-end laboratory balances plus the traditional OHAUS quality and support for years of trouble-free use!

Standard Features Include:

- Simple 2-key menu navigation
- Text prompts for fast setup
- Seven Application modes plus below balance weighing
- Brilliant backlit high resolution dot matrix display
- RS232 port for easy communication with computer or printer
- GLP compliant with user selectable outputs
- Five Language operational display text
- Protective in-use cover and security bracket
- Industry leading warranty and support
- NTEP Legal-For-Trade certified models

With the Explorer Pro Series, you get a better balance, a better warranty and better support!

Explorer[®] Pro Electronic Balances

Explorer Pro Analytical Models

The Explorer Pro Series features 4 analytical models with capacities up to 210g and 0.1mg readability for maximum accuracy. The new draftshield design and contoured fit provide optimum draft protection from wind currents for superior balance stability and reproducibility in challenging environments such as high traffic areas. Explorer Pro is perfect for university research, teaching laboratories and general lab applications.



Percent Weighing

Percent weighing allows you to place a reference load on the pan, and check other samples as a percent of the reference load.

Each new sample will be a “percentage” of the original reference, the display shows the variance in – or + percent of the reference.

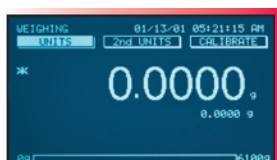
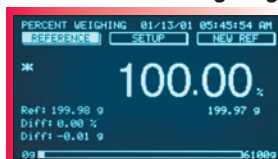

Weighing

Basic weighing with primary and secondary weighing units, time, date and capacity bar.

Gross/Net/Tare



G/N/T is an application mode commonly used when you need to identify the individual weights of the container, the material and both together. The container weight is the Tare weight, the material is called the Net weight and the container and material together are called the Gross weight. The Net weight is displayed on the readout.

Analytical Balances

Models without AutoCal™	EP64	EP114	EP214	EP214D*
Models with AutoCal™	EP64C	EP114C	EP214C	EP214DC*
Capacity (g)	62	110	210	100 / 210
Readability (mg)		0.1		0.1 / 1
Repeatability (Std. dev.) (mg)		0.1		0.1 / 0.5
Linearity (mg)		± 0.2		± 0.2 / 0.5
Weighing Units	gram, milligram, ounce, ounce troy, carat, pennyweight, Hong Kong Tael, Singapore Tael, Taiwan Tael, mommes, grain, tical, Newton, custom			
Application Modes	Weighing, Parts Counting, Animal/Dynamic Weighing, Checkweighing, Percent Weighing, Filling, Gross/Net/Tare Weighing			
Features	RS232 Port, Auxiliary Display Port, GLP Protocol, Selectable 5 Language Display Text, Selectable Displayed Information Settings, Selectable Environmental Filters, Selectable Auto-Print Settings, Integral Weigh Below Hook, Contrast & Brightness Control, Protective In-Use Cover			
Tare Range	Full Capacity by Subtraction			
Stabilization Time (seconds)	4			
Operating Temperature Range	50° to 86° F / 10° to 30° C without AutoCal™ 50° to 104° F / 10° to 40° C with AutoCal			
Power Requirements	100-120 V AC, 220-240 V AC, 50/60 Hz			
Calibration	External/Internal			
Display Type	High Resolution LCD Dot Matrix w/Backlight			
Pan Size (in/cm)	3.5 / 9			
Dimensions WxHxD (in/cm)	8.3 x 13.8 x 13.8 / 21 x 35 x 35			
Net Weight (lb/kg)	13.2 / 6			

*Moveable FineRange™

Analytical and Precision Balances

The Explorer Pro Series was designed with the user in mind. Explorer Pro features an ultra-simple and innovative user interface with on screen text prompts and scroll down menus. One-step operation guides you through Explorer Pro's application modes with a single button press. Explorer Pro's state of the art high-resolution display is easy to view and displays only the information you want to see. Plus, your investment is protected! Explorer Pro is designed with a spill channel and includes an in-use cover. The Explorer Pro is manufactured to ISO 9001 quality assurance specifications, for traditional OHAUS quality you've come to expect.

Key Features

Automatic Calibration

Explorer Pro's optional AutoCal™ calibration feature automatically calibrates the balance when it senses a temperature change sufficient enough to affect weighing accuracy. This feature assures accuracy while saving operational time.

Multi-Language Text

Explorer Pro offers 5 language operational display text. Standard language text includes: English, Spanish, French, Italian and German.

Large Brilliant Display

High-resolution dot matrix display with backlight for enhanced viewing in any environment. The large display screen features user definable text fields to illustrate only the information you want! The display also shows secondary units, time and date.

Text prompts simplify menu navigation and balance setup. Display features adjustable contrast and brightness controls.

Communication

The standard RS232 communication port offers connectivity to peripherals such as printers and computers.

GLP

Explorer Pro's connectivity capability allows for Good Laboratory Practice compliance. GLP protocol data such as time/date, balance/project, user ID, calibration information and weighing information can be printed or saved to a computer.

Leveling Feet for Quick Set-Up

Standard on all Explorer Pro models, the up-front level assures accurate operation.

Innovative Software

Simple to use and easy to follow, with no training or manual required! The 3 application-specific soft-keys allow direct access to features such as calibration, units, sample size and reference information at a touch of a button.

Protective Cover

Explorer Pro features a durable in-use cover as standard equipment. The replaceable cover protects the display from harsh environments or spills that can ruin the balance.



OHAUS Explorer Pro: Weighing Units for Every Application

For total versatility, Explorer Pro offers 7 application modes and 16 standard weighing units for almost any type of mass measurement application

Application Modes:

- Weighing
- Parts Counting
- Animal (Dynamic) Weighing
- Percent Weighing
- Checkweighing
- Filling
- Gross/Net/Tare Weighing

- Milligrams
- Grams
- Kilograms*
- Pounds*
- Ounces
- Carats
- Troy Ounces
- Newtons
- Grains
- User Programmable Custom Unit
- Mommes
- Taels (3)
- Ticals
- Pennyweights

*not available on Analytical units



Explorer Pro Precision Toploading Models

The Explorer Pro Series features 12 precision toploader models with capacities up to 8100g and readabilities to 0.1g for exceptional accuracy. The rugged design and versatility make the Explorer Pro ideal for applications in pharmaceutical, chemical, research and quality control and University research.

Explorer Pro precision balances are available with NTEP Legal-For-Trade certification. Contact OHAUS for details.

Dynamic / Animal Weighing

Dynamic weighing allows the user to weigh unstable matter that may be moving. This mode can be set to manual, semi-automatic, or automatic; the displayed data includes filtered weight and unfiltered weight. Displayed data also includes filter level, capacity bar graph and operation mode (manual, semi or auto).

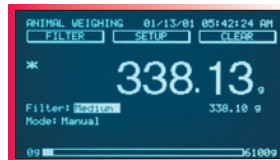

Parts Counting

Enhanced parts counting features include auto sample optimization, user definable sample size and manual entry using scroll keys. The “Parts Counting Check” feature allows for quickly checking a sample of pieces against a preset criteria, with results displayed as the number of pieces. The “Parts Counting Fill” feature allows for quickly checking a sample of pieces against an established criteria, with results displayed as a percentage of the preset target.

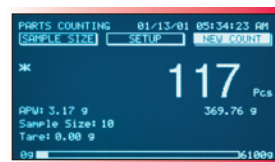

Precision Balances

Models without AutoCal™	EP213	EP413	EP613	EP413D	EP612	EP2102	EP4102	EP6102	EP4102D	EP4101	EP6101	EP8101
Models with AutoCal™	EP213C	EP413C	EP613C	EP413DC	EP612C	EP2102C	EP4102C	EP6102C	EP4102DC	EP4101C [§]	EP6101C [§]	EP8101C [§]
Capacity (g)	210	410	610	100 / 410	610	2100	4100	6100	1000 / 4100	4100	6100	8100
Readability (g)	0.001		0.001/0.01		0.01			0.01/0.1		0.1		
Repeatability (Std. dev.) (g)	0.0005		0.0015	0.0005/0.005		0.005		0.01	0.01/0.05		0.05	
Linearity (g)	± 0.002		± 0.002/0.005		± 0.02		± 0.04	± 0.02/0.05		± 0.1		
Weighing Units	gram, milligram, kilogram, pound, ounce, ounce troy, carat, pennyweight, Hong Kong Tael, Singapore Tael, Taiwan Tael, mommes, grain, tical, Newton, custom											
Application Modes	Weighing, Parts Counting, Animal/Dynamic Weighing, Checkweighing, Percent Weighing, Filling, Gross/Net/Tare Weighing											
Features	RS232 Port, Auxiliary Display Port, GLP Protocol, Selectable Language Display Text, Selectable Displayed Information Settings, Selectable Environmental Filters, Selectable Auto-Print Settings, Integral Weigh Below Hook, Contrast & Brightness Control, Protective In-Use Cover											
Tare Range	Full Capacity by Subtraction											
Stabilization Time (seconds)	3											
Operating Temperature Range	50° to 86° F / 10° to 30° C without AutoCal™ 50° to 104°F / 10° to 40°C with AutoCal™											
Power Requirements	100-120 V AC, 220-240 V AC, 50/60 Hz											
Calibration	External/Internal											
Display Type	High Resolution LCD Dot Matrix w/Backlight											
Pan Size (in/cm)	4.7/12 dia.				6.8 x 6.8/17.2 x 17.2 with Windshield					8 x 8/20.3 x 20.3 [§]		
Dimensions WxHxD (in/cm)	8.3 x 13.8 x 13.8 / 21 x 35 x 35				8.3 x 4 x 13.8 / 21 x 10.3 x 35							
Net Weight (lb/kg)	13.2/6				11/5							

* Moveable FineRange™

§ Balances with AutoCal™ are equipped with a 6 in x 6 in / 17.2 cm x 17.2 cm pan and windshield

Explorer Pro High Capacity Models

The Explorer Pro Series features 3 high capacity precision toploader models with capacities up to 32,000g and readabilities to 0.1g. The extra large 11" x 14" platform is ideal for laboratory and industrial applications in concrete/asphalt production, agriculture and quality control. Explorer High Capacity has been upgraded with Check and Differential Weighing, Statistical Functions, Formulation, and Filling.



Filling

Filling permits the user to preset a target reference weight, then add material to the balance to meet the target weight. The display shows the preset target weight and the percentage of the target by monitoring the differential data, the fill bar is split in two sections for fast filling up to 90%, then slower accurate fill to reach target (100%) weight.

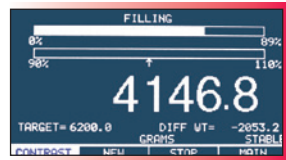

Checkweighing



Checkweighing is used when items need to be checked against a preset target, after the target weight is set, and over/under parameters are established. Checkweighing is measured as a factor of over the target, under the target, or accept. The display automatically shows the difference in percent and weight.

High Capacity Balances

Models without AutoCal™	EP12001†	EP22001†	EP32001†
Models with AutoCal™	EP12001C†	EP22001C†	EP32001C†
Capacity (g)	12000	22000	32000
Readability (g)	0.1		
Repeatability (Std. dev.) (g)	0.1		
Linearity (g)	± 0.4		
Weighing Units	gram, kilogram, pound, ounce, ounce troy, carat, pennyweight, Hong Kong Tael, Singapore Tael, Taiwan Tael, mommes, grain, tical, Newton, custom		
Application Modes	Weighing, Parts Counting, Filling, Animal Weighing, Checkweighing, Differential Weighing, Formulation, Quick Check, Statistics		
Features	RS232 Port, Auxiliary Display Port, GLP Protocol, Selectable Environmental Settings, Selectable Auto-Print Settings, Weigh Below Hook, Contrast & Brightness Control, Protective In-Use Cover		
Tare range	Full Capacity by Subtraction		
Stabilization Time (seconds)	4		
Operating Temperature Range	50° to 86° F / 10° to 30° C w/o AutoCal 50° to 104°F / 10° to 40°C w/ AutoCal		
Power Requirements	100-120 V AC, 220-240 V AC, 50/60 Hz		
Calibration	External/Internal		
Display Type	High Resolution LCD Dot Matrix w/Backlight		
Pan size (in/cm)	11 x 14 / 28 x 35.6		
Dimensions WxHxD (in/cm)	14 x 5.5 x 17.5 / 36 x 14 x 44.5		
Net Weight (lb/kg)	27 / 12.3		

† Not available in LFT (U.S.) / Type Approved versions

Explorer[®] Pro Electronic Balances

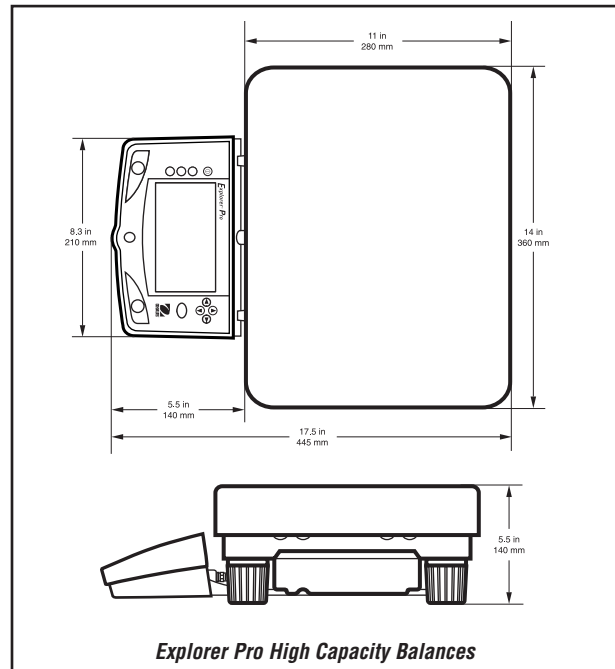
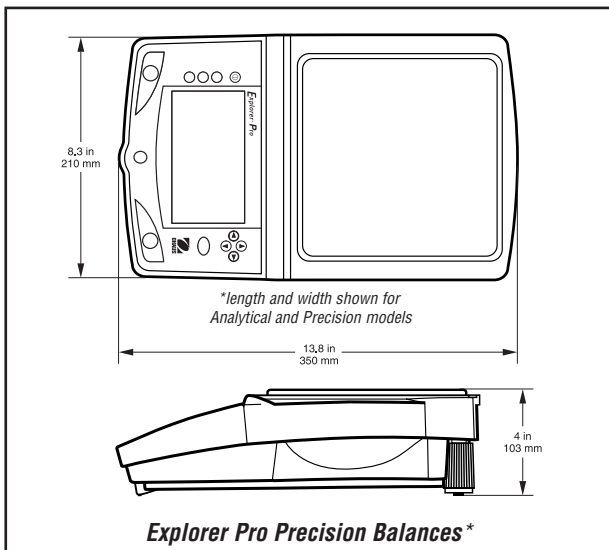
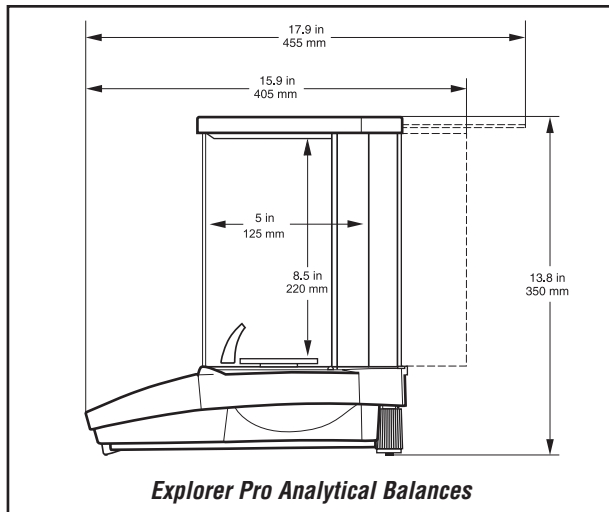

Additional Features

RS232 port for easy communication with computer or printer, GLP compliant with user selectable outputs, protective in-use cover, security bracket

Accessories

	Ohaus Number
Dot Matrix Printer	80252042
Cable kit to connect Dot Matrix Printer to Explorer Pro.....	80500570
Paper for Dot Matrix Printer	80251932
Ink Ribbon for Dot Matrix Printer	80251933
Thermal Printer.....	80251992
Paper for Thermal Printer	80251931
Cable kit to connect Thermal Printer to Explorer Pro	80252580
Ohaus Collect Software.....	80500746
TAL Software WinWedge	SW12W
RS232 Cable, PC 9 Pin to Explorer Pro	AS017-09
RS232 Cable, PC 25 Pin to Explorer Pro	AS017-02
Density Determination Kit for Explorer Pro analytical balances (0.1mg)	80253384
Security Device for Explorer Pro up to 8kg.....	470004-010
Modular Display Upgrade Kit for Explorer Pro up to 8kg	470008-010
In-Use Cover for Explorer Pro	80850042

Industry Leading Quality and Support

All OHAUS Explorer[®] Pro balances are manufactured under an ISO 9001:2008 Registered Quality Management System. Our rugged construction and stringent quality control have been hallmarks of all OHAUS products for over a century.

80774393_D © Copyright OHAUS Corporation

TEquipment USA
.NET
 An Interworld Highway, LLC Company

