

PSTA-600
PSTA-1200
PSTA-1600

Short Throw Projector Mounts

For projectors up to 25lb (11.3kg)

The PSTA series projector short throw kit is easily adjustable to accommodate ultra-short and short throw projector distance requirements and includes the Peerless-AV Universal PRS Projector Mount that makes image alignment easy with three axis of adjustment enabling precise image alignment.



Max load: 25lb (11.3kg)

FEATURES

- Aluminum alloy telescoping arm with lock down slot
- Fully integrated cable management system conceals and protects cables for a clean finish
- Kitted with Peerless-AV PRS projector mount offering:
 - +5/-20° Tilt
 - 360° Swivel
 - ±10° of Roll
- Variable extension options:
 - PSTA-600: 425-600mm
 - PSTA-1200: 755-1200mm
 - PSTA-1600: 1155-1600mm
- Fast and easy to install

UNIVERSAL COMPATABILITY

Three models and three different lengths to cover all short throw projectors



PSTA-600 shown

INTERNAL CABLE MANAGEMENT

Cable management access holes to route cables for a clean installation

ALL -IN-ONE SOLUTION

Kitted with Peerless-AV® Universal PRS



Cable Management

Touchboards

205 Westwood Ave, Long Branch, NJ 07740
Phone: 866-94 BOARDS (26273) / (732)-222-1511
Fax: (732)-222-7088 | E-mail: sales@touchboards.com



RoHS
2002/95/EC

peerless-AV™

Model Numbers

PSTA-600	Short Throw Projector Mount with arm length up to 23.62" (600mm)
PSTA-1200	Short Throw Projector Mount with arm length up to 47.2" (1200mm)
PSTA-1600	Short Throw Projector Mount with arm length up to 63" (1600mm)

Product Specifications

	DIMENSIONS (W x H x D)	PRODUCT WEIGHT	LOAD CAPACITY	FINISH	AVAILABLE COLORS
PSTA-600	25.0" x 9.6" x 10.6" (635 x 244 x 271mm)	8.5lb (3.8kg)	25lb (11.3kg)	Aluminum alloy, powder coat	Silver and Black
PSTA-1200	48.6" x 9.6" x 10.6" (1235 x 244 x 271mm)	12.5lb (5.6kg)			
PSTA-1600	64.37" x 9.6" x 10.6" (1635 x 244 x 271mm)	15.5lb (7.0kg)			

Package Specifications

	PACKAGE SIZE (L x W x H)	PACKAGE SHIP WEIGHT	PACKAGE UPC CODE	PACKAGE CONTENTS	UNITS IN PACKAGE
PSTA-600	20.7" x 10.1" x 11.0" (526 x 254 x 279mm)	10.5lb (4.7kg)	735029275749	Short throw arm, end cap, PRS-UNV, installation hardware, assembly instructions	1
PSTA-1200	32.5" x 10.1" x 11.0" (825 x 254 x 279mm)	14.5lb (6.5kg)	735029275756		
PSTA-1600	40.5" x 10.1" x 11.0" (1029 x 254 x 279mm)	17.5lb (7.9kg)	735029275763		

Accessories

ACC020:	Projector Security Cable
----------------	--------------------------

All dimensions = **inch** (mm)

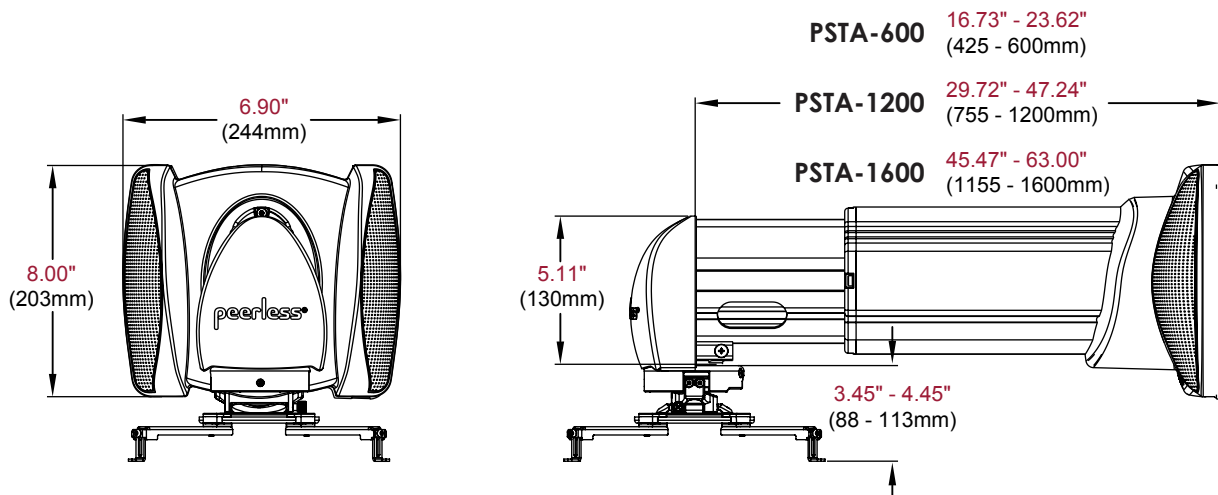

ARCHITECTS SPECIFICATIONS

The Short Throw Projector Mounts shall be Peerless-AV models PSTA-600, PSTA-1200 and PSTA-1600. Assembly and installation shall be done according to instructions provided by the manufacturer.