

SC590(-S)

Floor Cart

for 50" to 90" Flat Panel Displays

The SC590 Floor Cart offers the most complete mobile solution for any large screen application. This versatile presentation cart allows you to hold meetings with AV support or simply to display information. A full line of accessories enable the cart to be fully tailored to meet your specific requirements.



FEATURES

- Incremental tilt of -2° , 0° and $+5^{\circ}$ locks in the ideal viewing angle
- Internal cable management for clean, clutter free look
- Maneuvers easily on 4.00" (102mm) swivel casters, two locking
- Customizable with accessories



Display size: 50" - 90"



Max load: 300lb (136kg)



■ **INCREMENTAL TILT**
Incremental tilt of -2° , 0° and $+5^{\circ}$

■ **COMPONENT PLACEMENT**
Metal or tinted tempered glass shelves sold separately

■ **SAFE AND EASY MANEUVERABILITY**
4" swivel casters

RoHS 2002/95/EC **MADE IN USA**

Touchboards

205 Westwood Ave, Long Branch, NJ 07740
Phone: 866-94 BOARDS (26273) / (732)-222-1511
Fax: (732)-222-7088 | E-mail: sales@touchboards.com

peerless-AV

SC590(-S) Floor Cart for 50" to 90" Flat Panel Displays

Product Specifications

	DIMENSIONS (W x H x D)	PRODUCT WEIGHT	LOAD CAPACITY	FINISH	AVAILABLE COLORS
SC590(-S)	54.0" x 26.0" x 63.0" (1371 x 660 x 1600mm)	98lb (44.6kg)	300lb (136kg)	Power coat	SC590: Black SC590-S: Silver

Package Specifications

	PACKAGE SIZE (W x H x D)	PACKAGE SHIP WEIGHT	PACKAGE UPC CODE	PACKAGE CONTENTS	UNITS IN PACKAGE
SC590(-S)	57.75" x 19.25" x 7.75" (1466 x 488 x 196mm)	103lb (46.9kg)	SC590: 735029292425 SC590-S: 73502929437	Base, 2 legs, 4 wheels, 2 columns, adapter plate, 2 adapter brackets	1

Accessories

ACC310: Feet Accessory	ACC314: Laptop Arm	ACC318: Tempered Glass Shelf
ACC313: Metal Shelf	ACC316: Safety Belt	ACC319: Video Conferencing Shelf
		ACC964: Keyboard Tray

All dimensions = inch (mm)

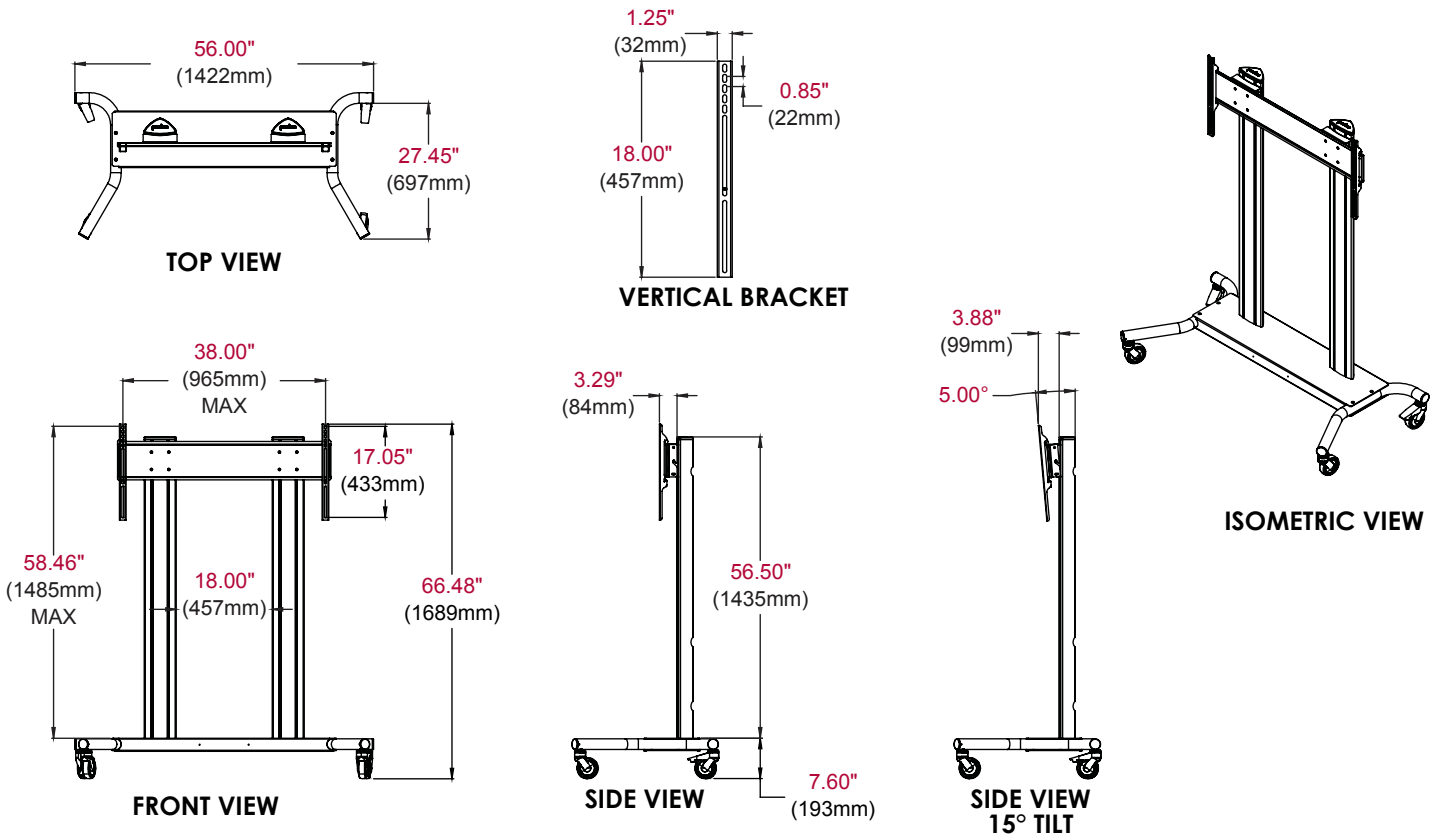

ARCHITECTS SPECIFICATIONS

The Floor Cart shall be a Peerless-AV model SC590(-S) and shall be located where indicated on the plans. It shall be finished in black or silver. Assembly and installation shall be done according to instructions provided by the manufacturer.