



SmartMount® Universal Tilt Wall Mount

For 32" to 56" Flat Panel Screens

MODELS

Universal Models:

Includes theft resistant hardware for attaching screen to mount

ST650 Black
ST650-S Silver

Includes standard hardware (hex or Phillips) for attaching screen to mount

ST650P Black
ST650P-S Silver

SCREEN ADAPTER



Mounting pattern

Universal Models: 29.5" W x 17.67" H
(749 x 449 mm)

VESA® pattern

Universal Models: Up to 600 x 400 mm

SPECIFICATIONS

	Distance from wall	2.67" (68 mm)
	Tilt	+15/-5°
	Max load	175 lb (79 kg)
	Product Dimensions (W x H x D)	30.87" x 18.5" x 2.67" (784 x 470 x 68 mm)
	Mounting Surfaces	Wood stud, concrete, cinder block and metal stud (Metal stud accessory required)
	Ship Weight	10.5 lb (4.76 kg)

1. Open wall plate design allows for total wall access, increasing electrical and cable management options
2. Pre-tensioned universal tilt adapters allow for +15/-5° tilt adjustment in one easy motion
3. Optional tilt lock in 5° increments
4. Easy-grip ratcheting handle locks angle into place
5. Horizontal screen adjustment up to 8" (203 mm)
6. Universal screen adapters easily hook onto wall plate for fast installation
7. Fits screens with mounting hole patterns: 29.5"W x 17.67"H (749 x 449 mm)



TECHNICAL DRAWINGS

For expanded product information and technical data visit www.peerlessmounts.com

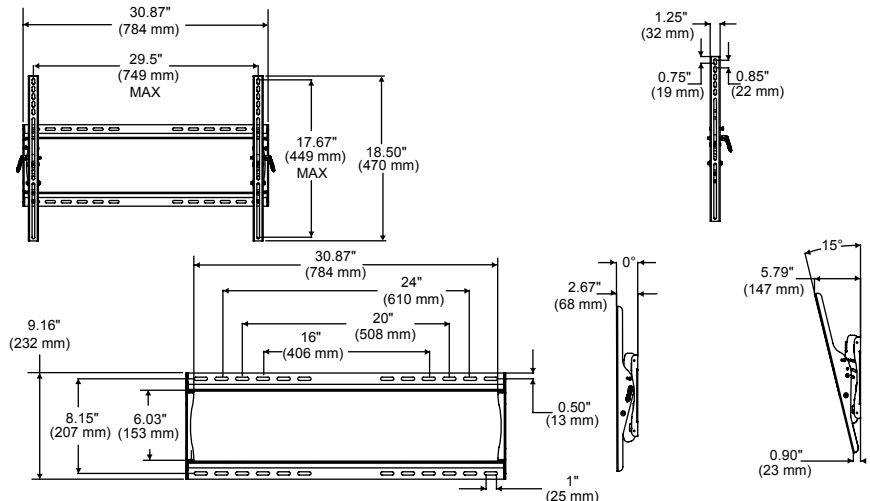

CERTIFICATIONS



ACCESSORIES



ACC415:
4-pack Metal Stud
Fastener Kit pg# 130



ACC309:
Video Conference Shelf pg# 115