

# Touchboards

205 Westwood Ave, Long Branch, NJ 07740

Phone: 866-94 BOARDS (26273) / (732)-222-1511

Fax: (732)-222-7088 | E-mail: sales@touchboards.com



## QD 3300 Visualizer

A full size visualizer at an affordable price!



### Highlighted Features

- The QD3300 from QOMO HiteVision is the most cost effective, full size Visualizer on the market! Its CMOS camera delivers crystal clear images and sharp text.
- The QD3300 uses a high speed USB connection for image capturing and video recording. The unique plug 'n play USB system means no drivers are necessary and it will interface with Mac's, PC's, as well as 3rd party software systems allowing you to build curriculum and seamlessly interface with any interactive product.
- The full size stage, lit by LED lights provides a versatile work surface allowing you to show your documents and 3 Dimensional objects with ease.
- The QD3300 provides a full A4 back lit stage allowing you to show your transparencies and X-Rays. With the special negative feature, you can even show your photographic negatives in positive form!
- Presentation features such as freeze, image rotation, and title capture enrich your presentation experience.
- Systems users will appreciate the switching and RS232 controls built into the QD3300; allowing the control of multiple devices from one location.

Specifications

Camera	
Image Sensor	1.3M CMOS
Output Resolution	1024x768
Optical Zoom	5X
Digital Zoom	10X
Input/Output	
Video Input - VGA	2
Video Output - VGA	2
Audio Input	2
Audio Output	Mini Jack
Imaging Features	
Image Storage	16
Negative	Yes
Freeze	Yes
Split	Yes
Title	Yes
Mirror	Yes
Rotation	0, 90, 180, 270
PC Connectivity	
Driver	Plug-n-Play
Frame Rate	15 fps
Computer Connectivity	USB
OS Support	PC, MAC
Lighting	
Lighting	2 LED Arm Lights
Light Box	8x1/2" x 11" LED Light
Control	
RS232 Control	Yes
Remote Control	Yes
Shooting area	320mmX240mm
Other	
Form Factor	Full Size
Weight	12 lbs
Power consumption	12W
Dimensions (WxDxH)	Setup: 20.1"x20.9"x22.4"
Dimensions (WxDxH)	Folded: 20.1"x 16.1"x4.7"

Dimensions

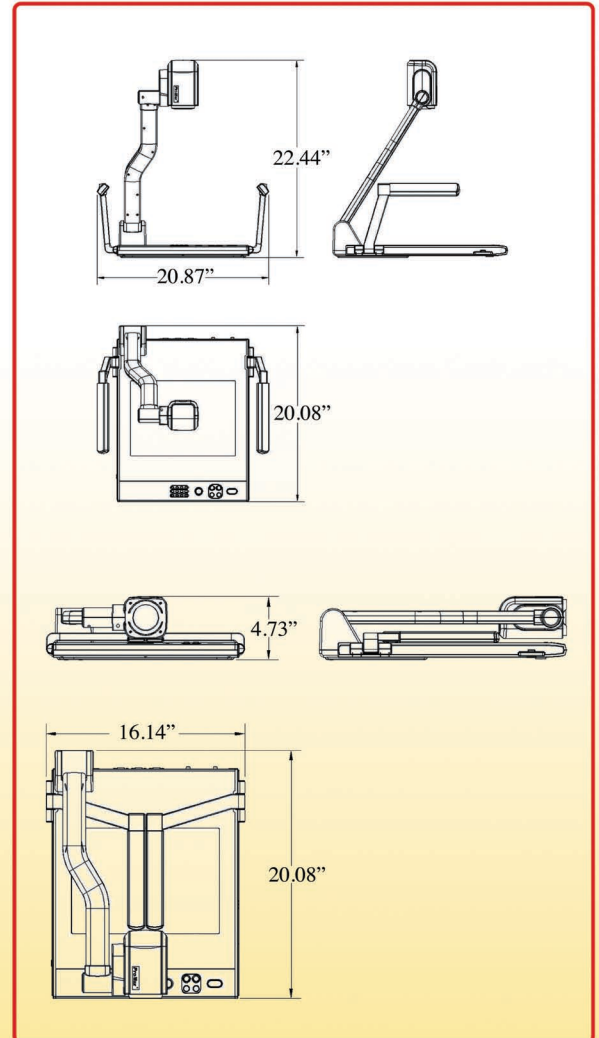

Presentation System



Design and specifications subject to change without notice.

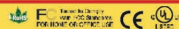

**Touchboards**  
 205 Westwood Ave, Long Branch, NJ 07740  
 Phone: 866-94 BOARDS (26273) / (732)-222-1511  
 Fax: (732)-222-7088 | E-mail: sales@touchboards.com