



Test & Measurement Products Catalog



About RIGOL

Founded in 1998, RIGOL Technologies, Inc. is an ISO9001:2000 Quality Management System and ISO14001:2004 Environmental Management System Certified company, an emerging T&M leader and a technology innovator in Electronic Measurement and Chemical Analysis. RIGOL's premium line of products includes Digital Oscilloscopes, RF Spectrum Analyzers, Digital Multimeters, Function/Arbitrary Waveform Generators, Digital Programmable Power Supplies, HPLC and UV-Vis Spectrophotometers, which help the engineers, researchers, educators to address their measurement challenges in confidence with affordability than ever before.

RIGOL Headquartered in Beijing, China, with the branch offices in Cleveland, OH, and Munich, Germany, the company's 400 employees and more than 150 distributors or representatives offer products and services in over 60 countries/regions on six continents. More information about RIGOL is available at www.rigol.com.

RIGOL Milestones

July,1998	RIGOL was founded in Beijing.
May,1999	RIGOL's first product RVO2100, a high performance Virtual Digital Storage Oscilloscope was introduced.
Mar,2002	DS3000 series , the RIGOL's first high performance Bench-Top DSO was introduced.
Feb,2004	DS5000 series, the China's first 1GSa/s real-time sample rate, up to 200MHz bandwidth DSO was introduced.
Apr,2006	RIGOL received ISO9001:2000 Quality Management System Certification.
Apr,2006	RIGOL DS1000CD series oscilloscope was introduced, the best Performance/Price Mixed Signal Oscilloscope (MSO) in the world.
July,2006	DG3000 and DG2000 series Function/Arbitrary Waveform Generator were introduced. The first Mixed Signal Generator (MSG) in the world with 1 analog channel and optional 16 digital channels.
Aug,2006	DM3000 series, RIGOL's 6½ digits Digital Multimeter was introduced.
Apr,2007	RIGOL jointly drafted the China National Standard GB/T 15289-07: "General Specification and Test Method for Digital Storage Oscilloscopes."
Apr,2007	RIGOL received ISO14001:2000 Environmental Management System Certification.
May,2007	DS1000A series, the China's first 2GSa/s real-time sampling rate, up to 300MHz bandwidth DSO was introduced.
May,2007	DG1000 series Function/Arbitrary Waveform Generator with build-in counter was introduced.
Oct,2007	RIGOL opened R&D center in Shanghai to strengthen its research and development capability.
Apr,2008	DS1000B series Digital Oscilloscope, the China's first DSO with 4-channels and LXI standard compliance was introduced.
Nov,2008	RIGOL was certified as Municipal Technology Center of Beijing.
Apr,2009	High-performance 80W, 3-output programmable linear DC power supply DP1308A was introduced.
Aug,2009	DSA1000A series Spectrum Analyzer with the digital IF technology was introduced.
Nov,2009	DS6000 series digital oscilloscope, the first DSO in China featuring 1GHz Bandwidth, 5GSa/s real time sample rate, 140Mpts Memory Depth and 180,000 wfm/s capture rate was introduced.
Feb,2010	DP1116A with up to 160W, single-output Programmable linear DC Power Supply was introduced.
July,2010	DG5000 series signal station, the world's first Arbitrary/Function Generator with I/Q modulation function in its class was introduced.
Oct,2010	High precision 6½ digits DM3068 was introduced.
June,2011	DS6104 Digital Oscilloscope won the 2011 R&D100 Awards in USA.
Aug,2011	DG4000 Series Function/Arbitrary Waveform Generator was introduced.
Sept,2011	DS4000 Series Digital Oscilloscope was introduced.
Oct,2011	DSA800 Series Spectrum Analyzer was introduced.
Feb,2012	DS2000 Series Digital Oscilloscope was introduced, the world's first uV/div level vertical sensitivity oscilloscope.
June,2012	DG4000 Series Function/Arbitrary Waveform Generator won the 2012 R&D100 Awards in USA.
Oct, 2012	DS2000-S Series Digital Oscilloscope with built in 2 channels 25MHz waveform generator was introduced.
Oct, 2012	DP800 Series Multi-channel Programmable linear DC Power supply was introduced.

DS6000 Series Digital Oscilloscope



► Features and Benefits

- Bandwidth 1GHz, 600 MHz
- Sample Rate Up to 5 GSa/s
- Channels 2 or 4
- Memory 140 Mpts(Std.)
- Waveform capture rate Up to 180,000 waveforms per second
- Real Time Waveform Record, Replay & Analysis(Std. up to 200,000 frames)
- Innovative "UltraVision" technology
- A variety of Trigger functions and Automatic measurements with statistics
- Support serial bus trigger(Std.) and decoding(Opt.)
- Dedicated data search knob" WaveFinder "
- Battery Option (China Only)
- Complete connectivity: USB Host& Device, LAN(LXI), AUX, VGA, USB-GPIB(Opt.)
- Built-in 1 GBytes Flash Memory
- 10.1 inch WVGA(800X480) Display

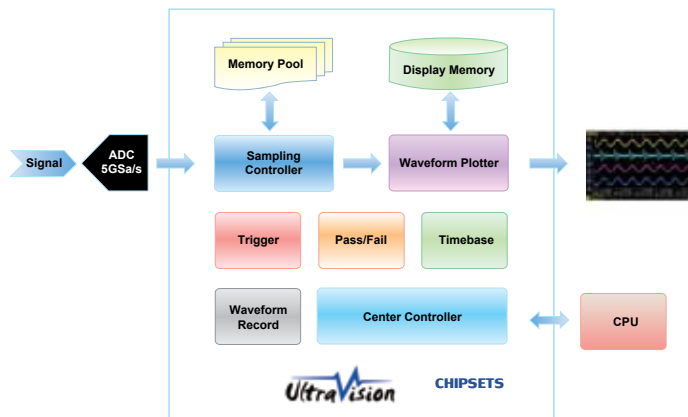

- Deeper Memory Depth(Std.140Mpts)
- Higher Waveform capture rate (Up to 180,000 wfms/s)
- Real Time waveform Record,Replay & Analysis (Up to 200,000 frames)
- Multi-level intensity grading display

► Features and Benefits

UltraVision: Up to 180K Waveforms/s Waveform capture rate



UltraVision: Real time waveform Record,Replay & Analysis



UltraVision: Multi-Level intensity grading display

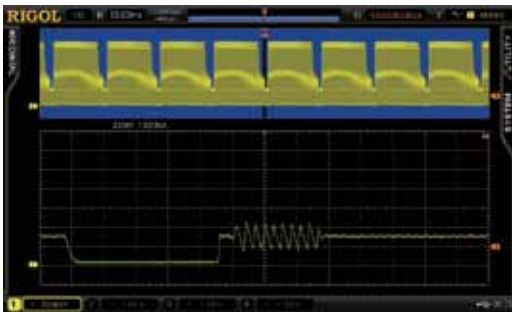

Advanced math function



Standard Mask test function

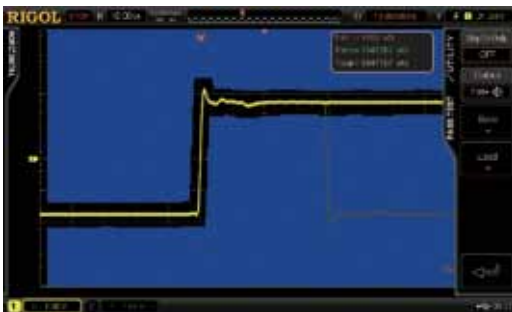

Auto measurements with statistics(Measure up to 5 parameters simultaneously)

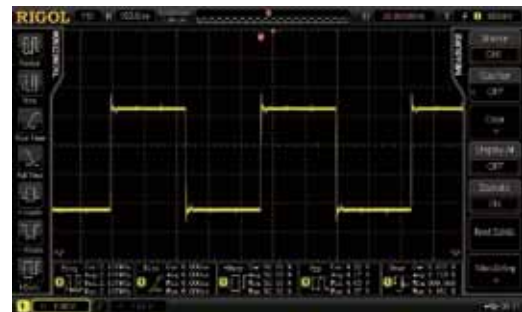

Standard Serial Bus trigger functions (RS232,I2C,SPI,CAN etc.)



Optional Serial bus decoding function with listing display



► Key Specifications

Model Number	DS6104	DS6102	DS6064	DS6062
Analog BW	1 GHz		600 MHz	
Channels	4	2	4	2
Max. Sample rate	5 GSa/s			
Max. Memory Depth	140 Mpts (Std.)			
Max. Waveform Capture rate	180,000 wfms/s			
Time Base Accuracy	≤ ±4 ppm			
Time Base Drift	≤ ±2 ppm/Year			
Timebase Scale	DS606X:1 ns/div to 1000 s/div DS610X:500 ps/div to 1000 s/div			
Input Impedance	1MΩ,50 Ω			
Vertical Scale	2 mV/div to 5 V/div(1 MΩ) 2 mV/div to 1 V/div(50 Ω)			
DC Gain Accuracy	±2% full scale			
Bandwidth Limit	20 MHz or 250 MHz			
Real Time waveform Record, Replay and Analysis function	Max. 200,000 frames(Std.)			
Std, trigger functions	Edge,Pulse width,Slope,Video,HDTV,Pattern, RS232/UART,I2C,SPI,CAN,USB,FlexRay			
Serial Bus decoding	RS232/UART,I2C,SPI,CAN,FlexRay			
Math functions	A+B,A-B,A×B,A/B,FFT,Advanced Math,Logic operation			
Auto Measurements	Vpp, Vamp, Vmax, Vmin, Vtop, Vbase, Vavg, Vrms, Overshoot, Preshoot, Area, Period Area, Freq., Period, Rise Time, Fall Time, +Width, -Width, +Duty, -Duty, Delay A→B rising edge, Delay A→B falling edge,Phase A→B rising edge,Phase A→B falling edge			
Connectivities	Dual USB HOST,USB DEVICE,LAN,VGA,10MHz Input/Output, Aux Output(TrigOut, Quick Edge, PassFail, Calibration, GND)			
Display	10.1 inches (257 mm) TFT LCD display,800 Horizontal ×RGB×480 Vertical Pixel, Multiple intensity grading			
Size (W×H×D)	399.0 mm× 255.3 mm×123.8 mm			
Weight	5.345 ± 0.2 kg (Without Package)			
Std. Probes	600MHz BW Passive Probe:4 sets for 4 channel models,2 sets for 2 channel models 1.5GHz BW Passive Probe:2 sets for DS6104,1 set for DS6102			

► Ordering Information

Model	Description	Order Number
	DS6104 (1 GHz, 4-channel)	DS6104
	DS6102 (1 GHz, dual-channel)	DS6102
	DS6064 (600 MHz, 4-channel)	DS6064
	DS6062 (600 MHz, dual-channel)	DS6062
Standard Accessories	Power Cord conforming to the standard of the country	-
	Front Panel Cover	FPC-DS-6
	USB Data Cable	CB-USB-150
	600MHz BW Passive Probe,4 sets for 4 channel models,2 sets for 2 channel models	RP5600A
	1.5GHz BW Passive Probe,2 sets for DS6104,1 set for DS6102	RP6150A
	Quick Guide	-
	Resource CD (User's Guide and Application Software)	-
Optional Accessories	1.5GHz Active Differential Probe	RP7150
	500MHz BW Passive Probes(Support all models)	RP3500
	600MHz BW Passive Probe(Support all models)	RP5600A
	1.5GHz BW Passive Probe(Support all models)	RP6150A
	11.1 V, 147 Wh Lithium Battery Set	BAT (China Only)
Decoding Options	USB to GPIB Module	USB-GPIB
	Desk Mount Instrument Arm	ARM
	Rack Mount Kit	RM-DS-6
	RS232/UART Decoding kit	SD-RS232-DS6
	I2C/SPI Decoding kit	SD-I2C/SPI-DS6
	CAN Decoding kit	SD-CAN-DS6
	FlexRay Decoding Kit	SD-FlexRay-DS6

DS4000 Series Digital Oscilloscope



► Features and Benefits

- Bandwidth 500MHz, 350MHz,200MHz,100MHz
- Sample Rate Up to 4GSa/s
- Channels 2 or 4
- Memory 140 Mpts(Std.)
- Waveform capture rate Up to 110,000 waveforms per second
- Real Time Waveform Record, Replay & Analysis(Std. up to 200,000 frames)
- Lower noise floor, the Min. vertical sensitivity is 1mV/div
- Innovative "UltraVision" technology
- A variety of Trigger functions and Automatic measurements with statistics
- Support serial bus trigger(Std.) and decoding(Opt.)
- Complete connectivity: USB Host& Device, LAN(LXI), AUX, VGA, USB-GPIB(Opt.)
- 9 inch WVGA(800X480) Display with 256 level intensity grading display

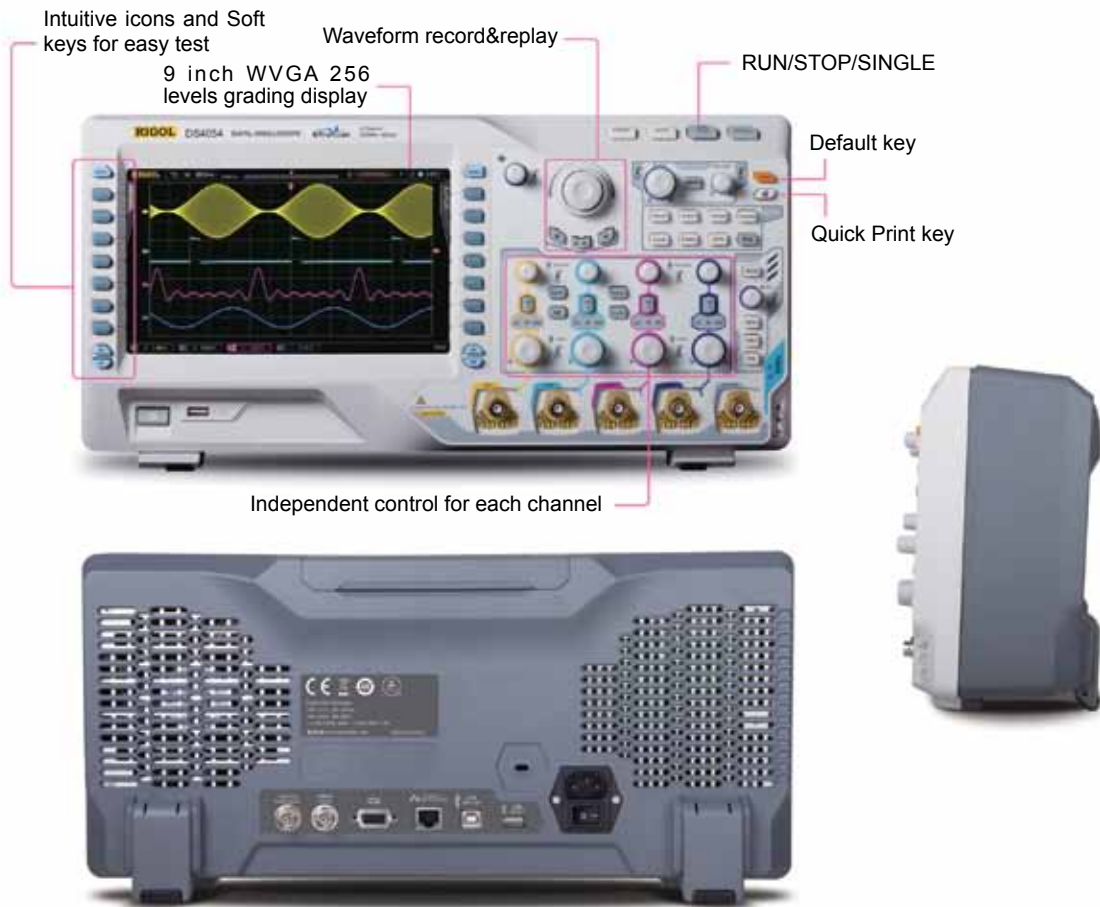

Product Dimensions: Width X Height X Depth = 440.0mm X 218.0 mm X 130.0 mm Weight: 4.8 kg ± 0.2 kg (Without Package)

► Innovative UltraVision Technology



- Deeper Memory Depth(Std.140Mpts)
- Higher Waveform capture rate (Up to 110,000 wfms/s)
- Real Time waveform Record,Replay & Analysis (Up to 200,000 frames)
- Multi-level intensity grading display(256 Levels)

► Features and Benefits

UltraVision: Up to 110K wfms/s Waveform capture rate

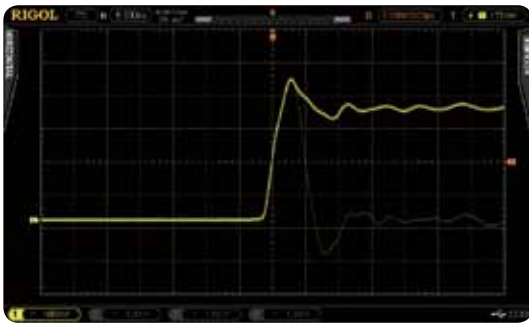

Find the infrequent problem easily

UltraVision: Realtime waveform record, replay, analysis function (std.)



- Up to 200,000 frames could be recorded
- "WaveFinder"-Dedicated data search knob
- Replay and analyze the recorded waveforms

UltraVision: Deeper Memory with up to 256-Level intensity grading display



Provide the capability to see both the panorama and detail simultaneously

Advanced math function (user defined)



Mask test functions(Std.)

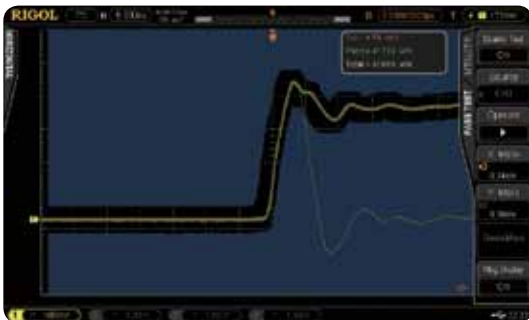

User defined Mask, Pass/Fail counts, Stop on Fail, Fail Alarm

Automatic measurements with statistics

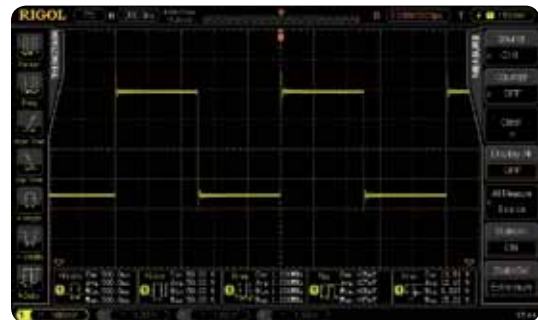

- Automatic measurements for Horizontal and vertical parameters
- Display up to 5 measurement items with statistics simultaneously
- Display all measurement items with the current value in the screen
- Intuitive icon and soft key operation for simplified testing

Serial bus decoding functions



Measurement History: Show the trend of the parameters

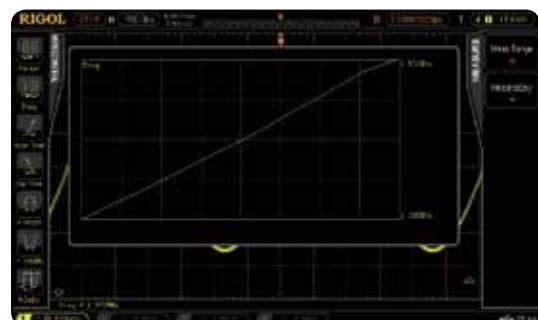

► Models and key Specs

Model Number	DS4054	DS4052	DS4034	DS4032	DS4024	DS4022	DS4014	DS4012
Analog BW	500 MHz		350 MHz		200 MHz		100 MHz	
Channels	4	2	4	2	4	2	4	2
Max. Sample rate	4 GSa/s							
Max. Memory Depth	140 Mpts							
Max. Waveform Capture rate	110,000 wfms/s							
Time Base Accuracy	$\leq \pm 4$ ppm							
Time Base Drift	$\leq \pm 2$ ppm/Year							
Time Base Scale	DS405x: 1 ns/div to 1000 s/div DS403x/DS402x: 2 ns/div to 1000 s/div DS401x: 5 ns/div to 1000 s/div							
Input Impedance	1M Ω , 50 Ω							
Vertical Scale	1 mV/div to 5 V/div(1 M Ω) 1 mV/div to 1 V/div(50 Ω)							
DC Gain Accuracy	$\pm 2\%$ full scale							
Bandwidth Limit	DS405x/ DS403x: 20 MHz/100MHz/200MHz DS402x: 20 MHz/100MHz DS401x: 20 MHz							
Real Time waveform Record, Replay and Analysis function	Max. 200,000 frames(Std.)							
Std, trigger functions	Edge, Nth Edge, Runt, Pulse width, Slope, Video, Pattern, RS232/UART, I2C, SPI, CAN, USB, FlexRay							
Serial Bus decoding	RS232/UART, I2C, SPI, CAN, FlexRay							
Math functions	A+B, A-B, A \times B, A/B, FFT, Advanced Math, Logic operation							
Auto Measurements	Vpp, Vamp, Vmax, Vmin, Vtop, Vbase, Vavg, Vrms, Overshoot, Preshoot, Area, Period Area, Freq, Period, Rise Time, Fall Time, +Width, -Width, +Duty, -Duty, Delay A→B rising edge, Delay A→B falling edge, Phase A→B rising edge, Phase A→B falling edge							
Connectivities	Dual USB HOST, USB DEVICE, LAN, VGA, 10MHz Input/Output, Aux Output(TrigOut, Quick Edge, PassFail, Calibration, GND)							
Display	9 inches (229 mm) TFT LCD display, 800 Horizontal \times RGB \times 480 Vertical Pixel, 256 intensity grading level							
Size (W \times H \times D)	440.0 mm \times 218.0 mm \times 130.0 mm							
Weight	4.8 kg \pm 0.2 kg (Without Package)							
Std. Probes	RP3500 500MHz BW Passive Probe: 2 or 4 sets							

► Ordering Information

Model	Description	Order Number
	DS4012 (100MHz, 2-channel)	DS4012
	DS4014 (100MHz, 4-channel)	DS4014
	DS4022 (200MHz, 2-channel)	DS4022
	DS4024 (200MHz, 4-channel)	DS4024
	DS4032 (350MHz, 2-channel)	DS4032
	DS4034 (350MHz, 4-channel)	DS4034
	DS4052 (500MHz, 2-channel)	DS4052
	DS4054 (500MHz, 4-channel)	DS4054
Standard Accessories	Power Cord conforming to the standard of the country	-
	Front Panel Cover	FPC-DS-4
	USB Data Cable	CB-USB-150
	2 or 4 Passive Probes (500 MHz)	RP3500
	Quick Guide	-
	Resource CD (User's Guide and Application Software)	-
Optional Accessories	Active Differential Probe (1.5 GHz)	RP7150
	Rack Mount Kit	RM-DS-4
Decoding Options	RS232/UART Decoding Kit	SD-RS232-DS4
	I2C/SPI Decoding Kit	SD-I2C/SPI-DS4
	CAN Decoding Kit	SD-CAN-DS4
	FlexRay Decoding Kit	SD-FlexRay-DS4

DS2000 Series Digital Oscilloscope



► Features and Benefits

- Wider vertical range(500uV/div ~ 10V/div), lower noise floor, Better for small signal capturing
- Full bandwidth, lower overshoot, perfect frequency response design
- Bandwidth 70MHz,100MHz,200MHz
- Max. Sample Rate 2G Sa/s
- Standard Memory Depth up to 14Mpts,Optional Memory Depth up to 56Mpts
- Innovative "UltraVision" technology
- Waveform capture rate up to 50,000 wfms/s
- 256 Levels intensity grading waveform display
- Up to 65,000 frames Hardware based real time waveform record and analysis function(Std.)
- A variety of trigger and serial bus decoding functions(RS232,I2C,SPI)
- Built in 2 channels 25MHz waveform generator(DS2000-S)
- Complete connectivity: USB Host& Device, LAN(LXI), AUX, USB-GPIB(Optional)
- Complete connectivities: USB Host,USB Device,LAN(LXI),AUX
- Compact size, light weight, easy to use
- 8 inch TFT (800x480) WVGA

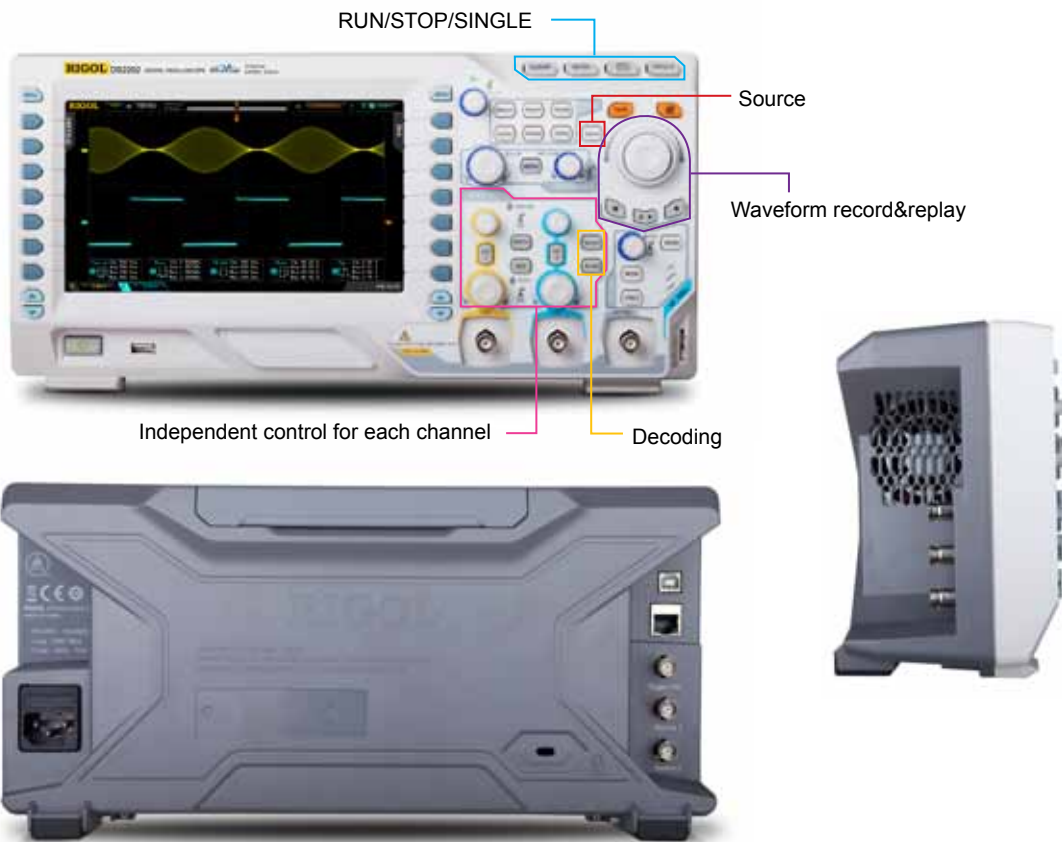

Product Dimensions: Width X Height X Depth=361.6 mm×179.6 mm×130.8 mm Weight: 3.9 kg ± 0.2 kg(Without Package)

► Innovative UltraVision Technology



- Deeper Memory Depth(Std. 14Mpts,Opt.56Mpts)
- Higher Waveform capture rate (Up to 50,000 wfms/s)
- Real Time waveform Record,Replay & Analysis (Up to 65,000 frames)
- Multi-level intensity grading display(Up to 256 Levels)

Versatile Trigger Functions(Runt, Nth Edge,Setup/ Hold ...)



Runt Trigger

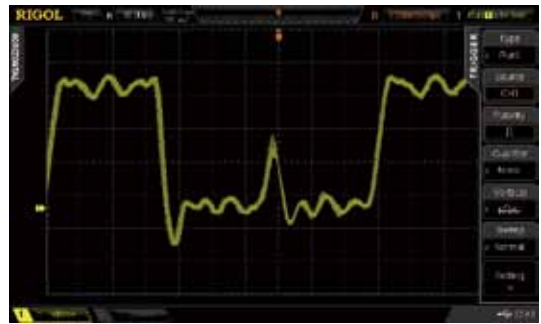

Std. Advanced Math Function

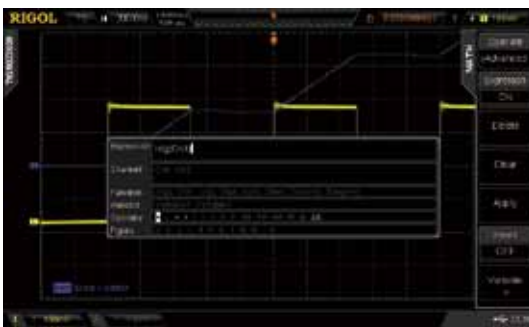

Std. Mask Test Function

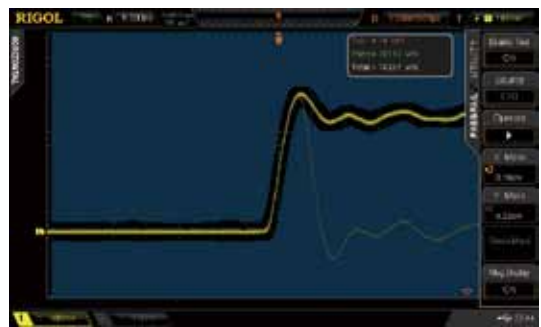

Built in 2 Channels 25MHz Waveform Generator(DS2000-S)

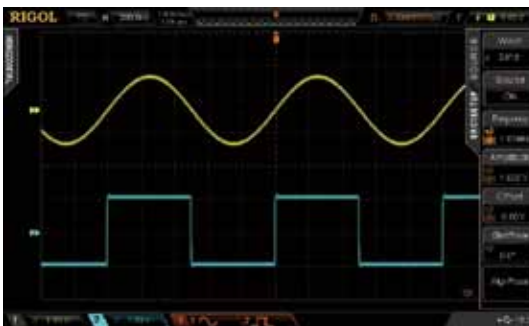

Built in ARB Waveform Generation Function(DS2000-S)



Automatic measurements with statistics

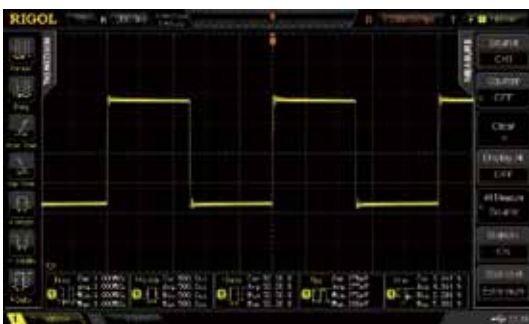

Complete Connectivity (USB Host& Device, LAN,AUX)



► Models and key Specs

Model Number	DS2072	DS2072-S	DS2102	DS2102-S	DS2202	DS2202-S
Analog BW	70 MHz		100MHz		200 MHz	
Channels	2					
Max. Sample rate	2GSa/s ((single-channel), 1GSa/s ((dual-channel)					
Max. Memory Depth	14Mpts (std.) , 56Mpts (option)					
Max. Waveform Capture rate	50,000 wfms/s					
Time Base Accuracy	≤ ± 25 ppm					
Time Base Drift	≤ ± 5 ppm/Year					
Time Base Scale	DS2202: 2 ns/div to 1000 s/div DS2102/DS2072: 5 ns/div to 1000 s/div					
Input Impedance	(1 MΩ ± 1%) (16 pF ± 3 pF)					
Vertical Scale	500 uV/div to 10 V/div					
DC Gain Accuracy	± 2% full scale					
Bandwidth Limit	DS2202: 20 MHz/100MHz DS2102/DS2072: 20 MHz					
Real Time waveform Record, Replay and Analysis function	Max. 65,000 frames(Std.)					
Std. trigger functions	Edge,Pulse width,Slope,Video,Pattern,Runt,SetupHold,RS232,I2C,SPI					
Optional trigger functions	Windows,Nth Edge,HDTV,Delay,Time Out,Duration,USB					
Std. Bus decoding	Parallel Bus					
Optional Serial Bus decoding	RS232,I2C,SPI					
Math functions	A+B,A-B,A × B,A/B,FFT,Advanced Math,Logic operation					
Auto Measurement	Peak Value, Top Value, Bottom Value, Amplitude, Average, Mean Square Root, Overshoot, Pre-shoot, Area, Period Area, Frequency, Period, Rise Time, Fall Time, Positive Pulse Width, Negative Pulse Width, Positive Duty Cycle, Negative Duty Cycle, Delay A→B \uparrow , Delay A→B \downarrow , Phase A→B \uparrow , Phase A→B \downarrow					
Connectivities	USB HOST(support USB-GPIB),USB DEVICE, LAN(LXI),Aux Output(TrigOut, PassFail)					
Display	8 inches (203 mm) TFT LCD display,800 Horizontal × RGB × 480 Vertical Pixel, 256 intensity grading level					
Size (W × H × D)	361.6 mm × 179.6 mm × 130.8 mm					
Weight	3.9 kg ± 0.2 kg (Without Package)					
Std. Probes	RP3300 350MHz BW Passive Probe:2 sets					

Model	DS2072-S	DS2102-S	DS2202-S
Channels	2		
Sample Rate	200MSa/s		
Vertical Resolution	14bits		
Max. Output Frequency	25MHz		
Standard Waveforms	Sine, Square, Triangle, Pulse, Noise, DC		
Arbitrary Waveform	Sinc, Exponential Rise, Exponential Fall, ECG, Gauss,HaverSine,Lorentz		
Frequency Range	Sine: 0.1Hz to 25MHz Square/Pulse: 0.1Hz to 15MHz Triangle: 0.1Hz to 100kHz Noise (-3dB BW): 25MHz (typ.) Arb Waveform: 0.1Hz to 10MHz		
Arb Waveform Length	2 ~ 16K ppints		
Frequency Accuracy	100ppm (<10kHz);50ppm (>10kHz)		
Amplitude	20mVpp~5Vpp(HZ); 10mVpp~2.5Vpp(50 Ω)		

► Ordering Information

Model	Description	Order Number
	DS2072(70MHz,2-Ch Scope)	DS2072
	DS2072-S(70MHz,2-Ch Scope + 2-Ch 25MHz Waveform generator)	DS2072-S
	DS2102(100MHz,2-Ch Scope)	DS2102
	DS2102-S(100MHz,2-Ch Scope + 2-Ch 25MHz Waveform generator)	DS2102-S
	DS2202(200MHz,2-Ch Scope)	DS2202
	DS2202-S(200MHz,2-Ch Scope + 2-Ch 25MHz Waveform generator)	DS2202-S
Standard Accessories	Power Cord conforming to the standard of the country	-
	USB Data Cable	CB-USB-150
	2 Passive Probes (350 MHz)	RP3300
	Quick Guide	-
	Resource CD (User's Guide and Application Software)	-
Optional Accessories	Rack Mount Kit	RM-DS-2
Deep Memory Option	56Mpts(single channel)/28Mpts(dual channel)	MEM-DS2
Advanced trigger Option	Windows, Nth Edge,HDTV,Delay, Time Out, Duration, USB	AT-DS2
Decoding Option	RS232,I2C,SPI Decoding Kit	SD-DS2

DS1000B Series Digital Oscilloscope



- Features and Benefits**
- 4 Analog Channels
 - 2GSa/s Real-time Sample Rate
 - Versatile Trigger Functions: Edge, Video, Pulse, Pattern and Alternate
 - Waveform Record and Replay function
 - Built in FFT and Digital Filters
 - Pass/Fail Test
 - High Definition Display (320x240)
 - Connectivity: USB Host & Device, LAN(LXI-C), Support PictBridge

► Key Specifications

Model	DS1204B	DS1104B	DS1074B
Bandwidth	200 MHz	100 MHz	70 MHz
Memory Depth	Up to 16 kpts (half channel), 8 kpts (each channel)		
Channels	4 channels + external trigger		
Real-time Sample Rate	2 GSa/s (half channel), 1 GSa/s (each channel)		
Equivalent-time Sample Rate	50 GSa/s	25 GSa/s	10 GSa/s
Rise Time	<1.75ns	<3.5ns	<5ns
Input Impedance	1 MΩ 18 pF		
Timebase Range	1 ns/div ~ 50 s/div	2 ns/div ~ 50 s/div	5 ns/div ~ 50 s/div
Trigger modes	Edge, Video, Pulse Width, Alternate, pattern trigger across 4 analog channels		
Vertical Sensitivity	2 mV/div ~ 10 V/div		
Vertical Resolution	8 bits		
Maximum Input voltage	All Inputs 1MΩ 18pF 300Vrms Max CAT I		



4 Analog Channels

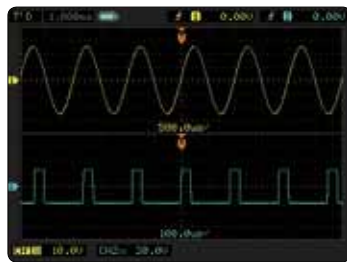

Alternative Trigger



2G Sa/s Sample Rate



Pass/Fail Test



Pattern Trigger



Waveform Record

DS1000 Series Digital Oscilloscope



► Features and Benefits

- 1G Sa/s Real time Sample Rate
- Memory Depth upto 1Mpts
- 2+16 Channels Mixed Signal Oscilloscope(MSO)(DS1000D)
- Versatile Trigger Functions:
 - Edge,Video,Pulse,Slope,Aalternate,Pattern(DS1000D),Duration(DS1000D)
- Trigger Sensitivity could be adjusted
- Waveform Record and Replay function
- Built in FFT and Digital Filters
- Pass/Fail Test
- Connectivity: USB Host & Device, RS-232, Support PictBridge

► Specifications

Model	DS1102E	DS1052E
	DS1102D	DS1052D
Bandwidth	100MHz	50MHz
Channels	2 Channels + External Trigger	
Real-time Sample Rate	1 GSa/s (Single Channel), 500 MSa/s (Dual Channels)	
Equivalent-time Sample Rate	25 GSa/s	10 GSa/s
Rise Time	3.5 ns	7 ns

Memory Depth	Mode	Max. Sample Rate	Normal Mode	Long Memory Mode
	One Channel		1 GSa/s	16 kpts
Dual Channels		500 MSa/s or less	16 kpts	1 Mpts
		500 MSa/s or less	8 kpts	N.A.
		250 MSa/s or less	8 kpts	512 kpts
Timebase Range	2 ns/div ~ 50 s/div		5 ns/div ~ 50 s/div	
Trigger Modes	Edge,Video,Pulse,Slope,Aalternate,Pattern(DS1000D),Duration(DS1000D)			
Vertical Resolution	8 bits			
Vertical Sensitivity	2 mV/div ~ 10 V/div			
Maximum Input Voltage	All inputs 1 MΩ 15 pF 300 V RMS CAT I			

MSO Logic Analyzer	DS1102D	DS1052D
Channels	16 logic Channels	
Sample Rate	200 MSa/s (each channel)	
Record Length	512 kpts (each channel)	
Trigger Modes	Pattern, Duration	
Threshold Selections	TTL=1.4 V, CMOS=2.5 V, ECL=-1.3 V, USER=-8 V to + 8 V	

► DS1000D Mixed Signal Oscilloscope(2+16 channels)



Logic Analyzer Module



Pattern Trigger
The trigger condition is a combination of the level of the signal and the edge



Duration Trigger
A combination of Pattern Trigger and Pulse Width Trigger capabilities make isolation of events easy

► Deep Memory

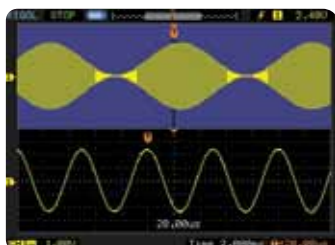

1Mpts Memory

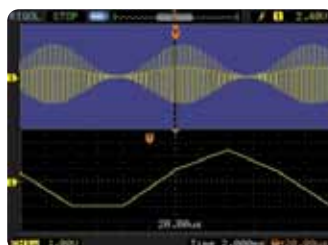

2Kpts Memory

See both the envelop and the detail of the waveform

RIGOL Digital Scope Probes

► RIGOL Passive Probes

Model Number	Type	Description
 RP2200	High Z Probe	1X: DC~7MHz 10X:DC~150MHz RIGOL scope Compatibility: All RIGOL Scopes.
 RP3300	High Z Probe	1X: DC~8MHz 10X:DC~350MHz RIGOL scope Compatibility: All RIGOL Scopes.
 RP3500	High Z Probe	DC~500MHz RIGOL scope Compatibility: All RIGOL Scopes.
 RP5600A	High Z Probe	DC~600MHz RIGOL scope Compatibility: DS4000,6000 Series.
 RP6150A	Low Z Probe	DC~1.5GHz RIGOL scope Compatibility: DS4000,6000 Series.
 RP1300H	High Voltage Probe	DC~300MHz CATI 2000V(DC+AC),CAT II 1500 V(DC+AC) RIGOL scope Compatibility: All RIGOL Scopes.
 RP1050H	High Voltage Probe	DC~50MHz DC:0~15KV DC,AC:pulse <=30KVp-p,AC:sine wave <=10KVrms RIGOL scope Compatibility: All RIGOL Scopes.

► RIGOL Active & Current Probes

Model Number	Type	Description
 RP7150	Differential / Single ended Probe	BW:DC~1.5GHz, 30V Peak, CAT I RIGOL scope Compatibility: DS4000, 6000 series.
 RP1001C	Current Probe	BW:DC~300kHz, Max.DC: ± 100A,AC P-P:200A,AC RMS:70A RIGOL scope Compatibility: All RIGOL Scopes.
 RP1002C	Current Probe	BW:DC~1MHz, Max.DC: ± 70A,AC P-P:140A,AC RMS:50A RIGOL scope Compatibility: All RIGOL Scopes.
 RP1003C	Current Probe	BW:DC~50MHz, Max.AC Peak:50A(Non-continuous),AC RMS:30A RIGOL scope Compatibility: All RIGOL Scopes.
 RP1004C	Current Probe	BW:DC~100MHz, Max.AC Peak:50A(Non-continuous),AC RMS:30A RIGOL scope Compatibility: All RIGOL Scopes.
 RP1005C	Current Probe	BW:DC~10MHz, Max.150Arms,300A peak(Non-continuous),500A peak(@Pulse width <=30 ms) RIGOL scope Compatibility: All RIGOL Scopes.
 RP1025D	High Voltage Differential Probe	BW:25MHz; Max. Voltage ≤ 1400Vpp RIGOL scope Compatibility: All RIGOL Scopes.
 RP1050D	High Voltage Differential Probe	BW:50MHz; Max. Voltage ≤ 7000Vpp RIGOL scope Compatibility: All RIGOL Scopes.
 RP1100D	High Voltage Differential Probe	BW:100MHz; Max. Voltage ≤ 7000Vpp RIGOL scope Compatibility: All RIGOL Scopes.

DSA1000 Series Spectrum Analyzer



► Features and Benefits

- All-digital IF Technology
- Displayed Average Noise Level (DANL) Up to -148dBm(DSA1030A), -138dBm(DSA1030), -120dBm(DSA1020)
- Phase Noise up to -88dBc/Hz (DSA1030A,@10kHz offset), -80dBc/Hz (DSA1030/DSA1020,@10kHz offset)
- Total Amplitude Accuracy:<1.0dB(DSA1030A),<1.5dB(DSA1030/1020)
- Minimum Resolution Bandwidth (RBW): 10Hz(DSA1030A), 100Hz(DSA1030/1020)
- 3GHz Tracking Generator (DSA1030A-TG, DSA1030-TG)
- Connectivity: USB Host& Device, LAN, VGA, USB-GPIB(Optional)
- 8.5 Inch Display (800x480)



Product Dimensions: Width X Height X Depth = 399 mm × 223 mm × 159 mm Weight: 6.2 kg (Without Package)

► **Features and Benefits**

Distinguish the two nearby signals clearly with the 10Hz RBW

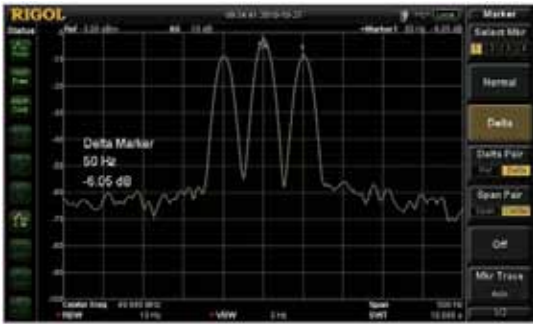

Readout the signal's Phase Noise directly by using the standard Noise Marker function

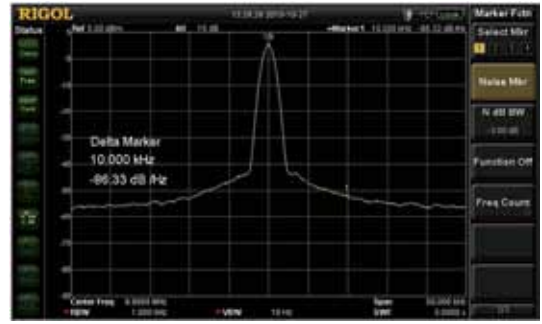

Compare the spectrums with different color trace

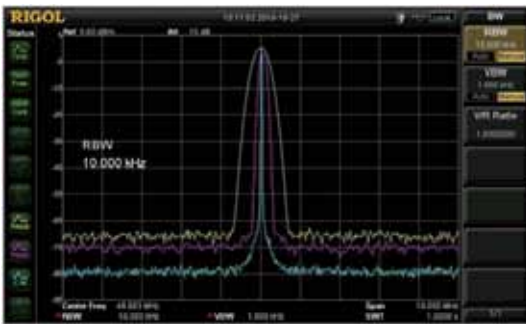

The advanced Channel Power measurement function



The advanced Occupied Bandwidth measurement function



Readout the Spectrum Peak values with the Peak table function



The advanced Harmonic distortion measurement function



AM Demodulation with "Zero Span"

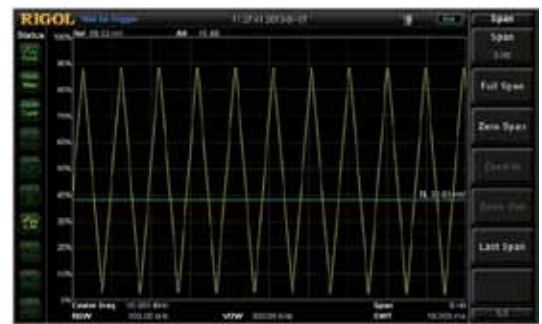

► Key Specifications

	DSA1030A/DSA1030A-TG	DSA1030/DSA1030-TG	DSA1020
Frequency Range	9 kHz~3 GHz		9 kHz~2 GHz
Frequency Resolution	1Hz		
Internal Frequency Reference	10 MHz		
Aging Rate	<3 ppm/year		
Temperature Drift	<3 ppm(20 °C to 30 °C)		
Marker Resolution	span / (sweep points-1)		
Marker Uncertainty	$\pm(\text{frequency indication} \times \text{frequency reference uncertainty} + 1\% \times \text{span} + 10\% \times \text{resolution bandwidth} + \text{marker resolution})$		
Resolution Bandwidth (-3 dB)	10 Hz to 1 MHz,in 1-3-10 sequence		100 Hz to 1 MHz,in 1-3-10 sequence
Video Bandwidth (-3 dB)	1 Hz to 3 MHz,in 1-3-10 sequence		
SSB phase noise (typical)	-88/Hz @10kHz Carrier Offset	-80dBc/Hz @10kHz Carrier Offset	
Level Measurement Uncertainty	<1.0dB	<1.5dB	
Displayed Average Noise Level (DANL):			
	0 dB RF Attenuation, RBW=10Hz, VBW=1Hz, RMS Average Detector, Trace Average \geq 50, Input Impedance=50 Ω , Tracking Generator Off.	0 dB RF Attenuation, RBW=100 Hz, VBW=1Hz, RMS Average Detector, Trace Average \geq 50, Input Impedance=50 Ω , Tracking Generator Off.	
	RBW = VBW = 10 Hz	RBW = 100 Hz, VBW = 10 Hz	
DANL (Preamp Off)			
100 kHz to 10 MHz	<-85 dBm-3 x (f/1 MHz) dB, typical -125 dBm	<-75 dBm-3 x (f/1 MHz) dB, typical -115 dBm	<-75 dBm-3 x (f/1 MHz) dB, typical -115 dBm
10 MHz to 2 or 2.5 GHz	<-127 dBm+3 x (f/1GHz) dB, typical -130 dBm	<-117 dBm+3 x (f/1 GHz) dB, typical -120 dBm	<-117 dBm+3 x (f/1 GHz) dB, typical -120 dBm
2.5 GHz to 3 GHz	<-115 dBm	<-105 dBm	
DANL (Preamp On)			
100 kHz to 1 MHz	<-103 dBm	<-93 dBm	
1 MHz to 10 MHz	<-103 dBm-3 x (f/1 MHz) dB, typical -143 dBm	<-93 dBm-3 x (f/1 MHz) dB, typical -133 dBm	
10 MHz to 2.5 GHz	<-145 dBm+3 x (f/1 GHz) dB, typical -148 dBm	<-135 dBm+3 x (f/1 GHz) dB, typical -138 dBm	
2.5 GHz to 3 GHz	<-133 dBm	<-123 dBm	
Preamplifier	Standard	Optional	None
Max. Damage Level	40 dBm(10 W)		
Trace Detectors	Normal, Positive-peak, Negative-peak, Sample, RMS, Voltage Average		
Trace Functions	Clear Write, Max Hold,Min Hold, Average, Freeze, Blank		
Units of Level Axis	dBm, dBmV, dB μ V, nV, μ V, mV, V, nW, μ W, mW, W		
Tracking Generator(-TG)	10 MHz to 3 GHz, 9 kHz settable		None
10 MHz Reference Input/Output	Support		
Advanced Measurement Kit	Standard	Optional	None
Display	8.5" TFT LCD, 800*480 Resolution		
Interface	LAN, USB Host&Device, VGA, USB-GPIB(Optional)		
Weight	6.2 kg(Without Package)		
Dimensions (W×H×D)	399 mm × 223 mm × 159 mm		

► Options and Accessories

Harmonic Distortion	TOI	Emission Bandwidth
Channel Power	Occupied Bandwidth	
Time Domain Power	Carrier to Noise Ratio	
Adjacent Channel Power	Pass/Fail	

Advanced Measurement Kit
(DSA1000-AMK)



Rack Mount Kit
(DSA1000-RMSA)

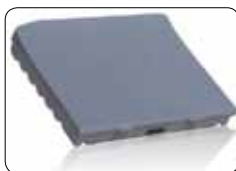

Lithium Battery Set
(China Only)



Soft Carrying
Bag(DSA1000-SCBA)



VSWR Bridge
(VB1020/VB1040)



USB to GPIB Converter
(USB-GPIB)



Desk Mount Instrument Arm
(ARM)



RF Demo Kit
(TX1000)



DSA Accessories
(DSA Utility Kit)



DSA PC Software
(Ultra Spectrum)

► Ordering Information

	Description	Order Number
Model	Spectrum Analyzer, 9 kHz to 3 GHz, with preamplifier	DSA1030A
	Spectrum Analyzer, 9 kHz to 3 GHz, with preamplifier, with track generator	DSA1030A-TG
	Spectrum Analyzer, 9 kHz to 2 GHz	DSA1020
	Spectrum Analyzer, 9 kHz to 3 GHz	DSA1030
	Spectrum Analyzer, 9 kHz to 3 GHz, with track generator	DSA1030-TG
Standard	Front Panel Cover	-
Accessories	Quick Guide (Hard Copy)	-
	CDROM (User Guide, Programming Guide)	-
	USB Cable	-
	Power Cable	-
	Options	DSA PC Software
	Preamplifier (not applied for DSA1020)	DSA1030-PA
	Advanced Measurement Kit (for DSA1030 , DSA1030-TG)	DSA1000-AMK
	VSWR Bridge (2GHz)	VB1020
	VSWR Bridge (4GHz)	VB1040
	USB to GPIB Interface Converter for Instrument	USB-GPIB
	11.1 V, 147 Wh Li-ion Battery Pack	BAT
	RF Demo Kit(Transmitter)	TX1000
	DSA Accessories Package	DSA Utility Kit
Optional Accessories	Rack Mount Kit	DSA1000-RMSA
	Front Panel Cover	DSA1000-FPCS
	Soft Carrying Bag	DSA1000-SCBA
	Desk Mount Instrument Arm	ARM
Orderable Manuals (Hard Copy)	Quick Guide, Chinese (for DSA1030A, DSA1030A-TG)	QGD010
	Quick Guide, English (for DSA1030A, DSA1030A-TG)	QGD011
	User Guide, Chinese (for DSA1030A, DSA1030A-TG)	UGD010
	User Guide, English (for DSA1030A, DSA1030A-TG)	UGD011
	Programming Guide, Chinese (for DSA1030A, DSA1030A-TG)	PGD010
	Programming Guide, English (for DSA1030A, DSA1030A-TG)	PGD011
	Quick Guide, Chinese (for DSA1030, DSA1030-TG, DSA1020)	QGD020
	Quick Guide, English(for DSA1030, DSA1030-TG, DSA1020)	QGD021
	User Guide, Chinese(for DSA1030, DSA1030-TG, DSA1020)	UGD020
	User Guide, English(for DSA1030, DSA1030-TG, DSA1020)	UGD021
	Programming, Chinese(for DSA1030, DSA1030-TG, DSA1020)	PGD020
	Programming, English(for DSA1030, DSA1030-TG, DSA1020)	PGD021

DSA800 Series Spectrum Analyzer



► Features and Benefits

- All-Digital IF Technology
- 9 kHz - 1.5 GHz Frequency Range
- Up to -135dBm Displayed Average Noise Level (DANL)
- -80dBc/Hz @ 10kHz Offset Phase Noise
- Total Amplitude Uncertainty < 1.5dB
- 100Hz Minimum Resolution Bandwidth (RBW)
- 1.5GHz Tracking Generator (DSA815-TG)
- Advanced Measurement functions (Opt.)
- EMI Filter & Quasi-Peak Detector Kit(Opt.)
- VSWR Measurement Kit(Opt.)
- Complete Connectivity: LAN,USB host,USB device,GPIB (Opt.)
- 8 Inch WVGA (800x480) Display
- Compact Size,Light weight design



Product Dimensions: Width X Height X Depth = 361.6 mm x 178.8 mm x 128 mm Weight: 4.25 kg (Without Package)

► Options and Accessories

Harmonic Distortion	TOI	Emission Bandwidth
Channel Power	Occupied Bandwidth	
Time Domain Power	Carrier to Noise Ratio	
Adjacent Channel Power	Pass/Fail	

Advanced Measurement Kit
(DSA1000-AMK)



Rack Mount Kit
(DSA1000-RMSA)



USB to GPIB Converter
(USB-GPIB)



RF Demo Kit
(TX1000)



DSA Accessories
(DSA Utility Kit)



DSA PC Software
(Ultra Spectrum)



VSWR Bridge
(VB1020)

► **Features and Benefits**

Distinguish the two nearby signals clearly with the 100Hz RBW

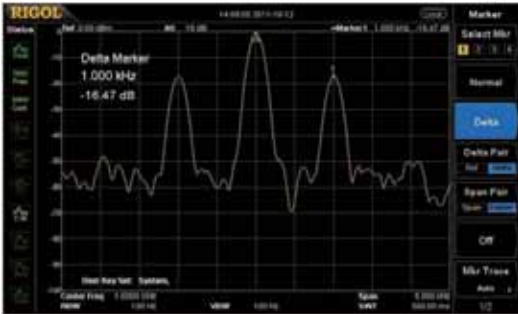

Compare the spectrums with different color trace

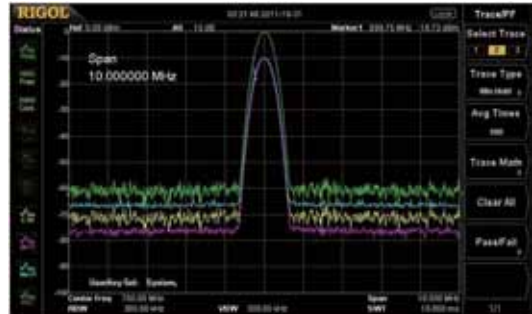

Readout the Spectrum Peak values with the Peak table function



Measure lower than -130dBm signal with the standard Preamplifier

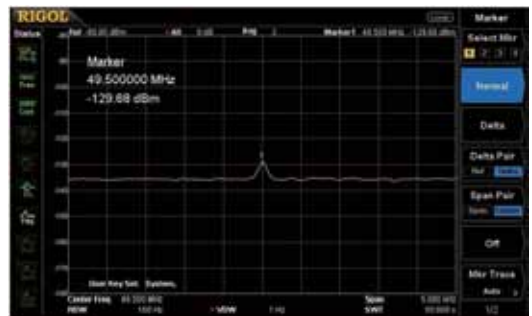

-80dBc/Hz @10 kHz offset Phase Noise

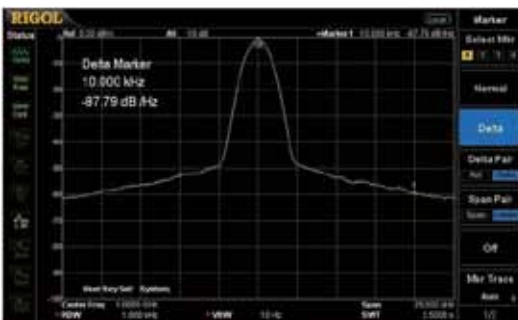

EMI Kit(EMI Filter & Quasi-Peak & Pass_Fail)

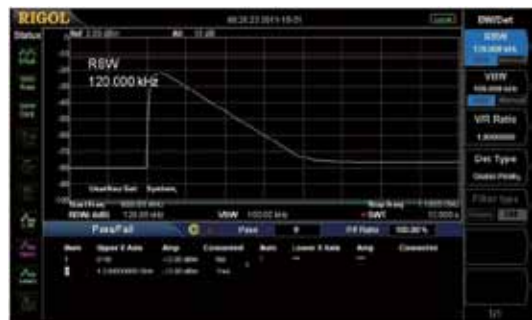

The GUI to control the RF Demo Kit (Transmitter) directly

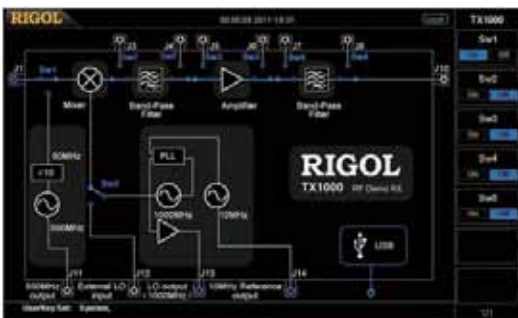

VSWR Measurement



► Key Specifications

Frequency Range	9kHz to 1.5GHz
Frequency Resolution	1Hz
Resolution Bandwidth (-3 dB)	100 Hz to 1 MHz, in 1-3-10 sequence
Video Bandwidth (-3 dB)	1 Hz to 3 MHz, in 1-3-10 sequence
SSB phase noise (typical)	<-80 dBc/Hz @10 kHz offset
Level Measurement Uncertainty	<1.5dB
Displayed Average Noise Level (DANL)	
0 dB RF Attenuation, RBW=VBW=100 Hz, Sample Detector, Trace Average ≥ 50, Input Impedance=50 Ω, Tracking Generator Off.	
Preamplifier Off	100 kHz to 1 MHz: <-90 dBm, typ. -110 dBm
	1 MHz to 1.5 GHz: <-110 dBm+6 x (f/1GHz) dB, typ. -115 dBm
Preamplifier On	100 kHz to 1 MHz:<-110 dBm typ. -130 dBm
	1 MHz to 1.5 GHz: <-130 dBm+6 x (f/1 GHz) dB, typ. -135 dBm
Preamplifier	Standard
Max. Damage Level	+30 dBm (1W)
Trace Detectors	Normal, Positive-peak, Negative-peak, Sample, RMS, Voltage Average, Quasi-peak
Trace Functions	Clear Write, Max Hold, Min Hold, Average, View, Blank
Units of Level Axis	dBm, dBmV, dBμV, nV, μV, mV, V, nW, μW, mW, W
Tracking Generator (-TG)	9 kHz to 1.5 GHz
10 MHz Reference Input/Output	Support
Advanced Measurement Kit	Optional
Display	8 inch 800 x 480 pixels Resolution 64k Colors
Interface	LAN,USB Host&Device,USB-GPIB(Optional)
Weight	4.25kg (With TG)
Dimensions (W×H×D)	361.6 mm x 178.8 mm x 128 mm

► Ordering Information

	Description	Order Number
Model	Spectrum Analyzer, 9 kHz to 1.5 GHz with preamplifier	DSA815
	Spectrum Analyzer, 9 kHz to 1.5 GHz, with preamplifier, with track generator	DSA815-TG
Standard Accessories	Quick Guide (Hard Copy)	QGD03X00
	CDROM (User's Guide, Programming Guide)	-
	Power Cable	-
Options	EMI Filter & Quasi-Peak Detector Kit	DSA800-EMI
	VSWR Measure Kit	DSA800-VSWR
	VSWR Bridge (2 GHz)	VB1020
	DSA PC Software	Ultra Spectrum
	Advanced Measurement Kit	DSA800-AMK
	USB to GPIB Interface Converter for Instrument	USB-GPIB
	RF Demo Kit (Transmitter)	TX1000
	DSA Accessories Package	DSA Utility Kit
Optional Accessories	Rack Mount Kit	DSA800-RMSA
Orderable Manuals (Hard Copy)	Quick Guide, Chinese& English	QGD03X00
	User's Guide, Chinese	UGD03000
	User's Guide, English	UGD03100
	Programming Guide, Chinese	PGD03000
	Programming Guide, English	PGD03100

DG5000 Series Function/Arbitrary Waveform Generators



► Features and Benefits

- 350 MHz, 250 MHz, 100 MHz, 70 MHz maximum output frequency
- 1 GSa/s sample rate, 14 bits vertical resolution
- Up to 128Mpts Editable Arbitrary Waveform
- Complete Isolation Between Channels and Support Freq/Phase Coupling
- 2+16 Mixed Signal Source (Opt.)
- Rise/Fall Time of the Pulse could be adjusted separately.
- Support Frequency Hopping and IQ Modulation
- Powerful Waveform Editing PC Software
- Connectivity: USB Host & Device, LAN, GPIB

► Key Specifications

Model	DG5352	DG5252	DG5102	DG5072
	DG5351	DG5251	DG5101	DG5071
Channel	2/1	2/1	2/1	2/1
Maximum Frequency	350 MHz	250 MHz	100 MHz	70 MHz
Sample Rate	1 GSa/s			
Waveforms				
Standard Waveforms	Sine, Square, Ramp, Pulse, Noise			
Arbitrary Waveforms	Sinc, Exponential Rise, Exponential Fall, ECG, Gauss, HaverSine, Lorentz, Dual-Tone, DC			
Frequency Characteristics				
Sine	1 μ Hz to 350 MHz	1 μ Hz to 250 MHz	1 μ Hz to 100 MHz	1 μ Hz to 70 MHz
Square	1 μ Hz to 120 MHz	1 μ Hz to 120 MHz	1 μ Hz to 100 MHz	1 μ Hz to 70 MHz
Ramp	1 μ Hz to 5 MHz	1 μ Hz to 5 MHz	1 μ Hz to 3 MHz	1 μ Hz to 3 MHz
Pulse	1 μ Hz to 50 MHz	1 μ Hz to 50 MHz	1 μ Hz to 50 MHz	1 μ Hz to 50 MHz
Noise	250 MHz Bandwidth			
Arb	1 μ Hz to 50 MHz	1 μ Hz to 50 MHz	1 μ Hz to 50 MHz	1 μ Hz to 50 MHz
Resolution	1 μ Hz			
Accuracy	± 1 ppm, 18 $^{\circ}$ C to 28 $^{\circ}$ C			
Sine Wave Spectrum Purity				
Harmonic Distortion	Typical (0 dBm) ≤ 100 MHz: < -45 dBc > 100 MHz: < -35 dBc	Typical (0 dBm) ≤ 100 MHz: < -45 dBc > 100 MHz: < -35 dBc	Typical (0 dBm) ≤ 100 MHz: < -45 dBc	Typical (0 dBm) \leq 70MHz: < -45 dBc
Total Harmonic Distortion	$< 0.5\%$ (10 Hz to 20 kHz, 0 dBm)			
Spurious (non-harmonic)	Typical (0 dBm) ≤ 100 MHz: < -50 dBc > 100 MHz: -50 dBc+6dBc/octave	Typical (0 dBm) ≤ 100 MHz: < -50 dBc > 100 MHz: -50 dBc+6dBc/octave	Typical (0 dBm) \leq 100MHz: < -50 dBc	ypical (0 dBm) \leq 70MHz: < -50 dBc
Phase Noise	Typical (0 dBm, 10 kHz deviation) 10 MHz: < -110 dBc			
Signal Characteristics				
Square				
Rise/Fall Time	Typical Value (1Vpp) < 2.5 ns	Typical Value (1Vpp) < 2.5 ns	Typical Value (1Vpp) < 3 ns	Typical Value (1Vpp) < 4 ns
Overshoot	Typical Value (1Vpp) $< 5\%$			
Duty Cycle	≤ 10 MHz: 20.0% to 80.0% 10 MHz to 40 MHz: 40.0% to 60.0% > 40 MHz: 50.0% (fixed)			
Non-symmetry	1% of period + 5 ns			
Jitter (rms)	Typical Value (1Vpp) ≤ 30 MHz: 10ppm+500 ps > 30 MHz: 500 ps			
Arb				
Waveform Length	Normal Mode: 2 to 16Mpts Play Mode : 2 to 128Mpts			
Vertical Resolution	14 bits			
Mode	Normal Mode, Play Mode			
Sample Rate	Normal Mode (Waveform Length is from 2 to 16Mpts): 1G Sa/s (fixed) Play Mode (Waveform Length is from 2 to 128Mpts): ≤ 1 G Sa/s (variable)			

Output Characteristics				
Amplitude (into 50 Ω)				
Range	≤ 100 MHz: 5 mVpp to 10 Vpp	≤ 300 MHz: 5 mVpp to 5 Vpp	≤ 250MHz: 5mVpp to 5Vpp	5mVpp to 10Vpp
	≤ 350 MHz: 5 mVpp to 2 Vpp			
Accuracy	Typical (1 kHz Sine, 0 V Deviation, >10 mVpp, Auto)			
	± 1% of setting ± 1 mVpp			
Amplitude	<10MHz: ±0.1dB	10MHz: ±0.1dB	<10MHz: ±0.1dB	<10MHz: ±0.1dB
Flatness	10MHz to 60MHz: ±0.2dB	10MHz to 60MHz: ±0.2dB	10MHz to 60MHz: ±0.2dB	10MHz to 60MHz: ±0.2dB
(relative to 100	60MHz to 100MHz: ±0.4dB	60MHz to 100MHz: ±0.4dB	60MHz to 100MHz: ±0.4dB	60MHz to 70MHz: ±0.4dB
kHz, 1.25Vpp Sine	100MHz to 250MHz: ±1.0dB	100MHz to 250MHz: ±1.0dB		
wave,	>250MHz: ±1.5dB			
50Ω)				
Units	Vpp, Vrms, dBm, High Level, Low Level			
Protection	Over-temperature protected, Short-circuit protected, Overload relay automatically disables main output			

FH Characteristic				
FH Bandwidth	1.5 MHz to 250 MHz	1.5 MHz to 250 MHz	1.5 MHz to 100 MHz	1.5 MHz to 70 MHz
FH Rate	1 Hop/s to 12.5M Hop/s			
Frequency Point Numbers	4096			
Sequence Length	4096			
Modulation Characteristics				
Modulation Types	AM, FM, PM, ASK, FSK, PSK, PWM, IQ			

IQ				
Carrier Waveform	Sine (max. 200 MHz)	Sine (max. 200 MHz)	Sine (max. 100 MHz)	Sine (max. 70 MHz)
Source	Internal/External			
Code Pattern	PN Sequence, 4 bits code pattern, User			
IQ Mapping	4QAM, 8QAM, 16QAM, 32QAM, 64QAM, BPSK, QPSK, OQPSK, 8PSK, 16PSK, User			
Code Rate	1 bps to 1 M bps			

Burst Characteristics				
Carrier Waveforms	Sine, Square, Ramp, Pulse, Noise, Arb (except DC)			
Carrier Frequency	1 μHz to 120 MHz	1 μHz to 120 MHz	1 μHz to 100 MHz	1 μHz to 70 MHz
Burst Count	1 to 1 000 000 or Infinite			
Start/Stop Phase	0° to 360°			
Internal Period	1 μs to 500 s			
Gated Source	External Trigger			
Trigger Source	Internal, External or Manual			
Trigger Delay	0 ns to 85 s			

► Ordering Information

	Description	Order Number
Model	DG5352 (350 MHz, dual-channel)	DG5352
	DG5351 (350 MHz, single channel)	DG5351
	DG5252 (250 MHz, dual-channel)	DG5252
	DG5251 (250 MHz, single channel)	DG5251
	DG5102 (100 MHz, dual-channel)	DG5102
	DG5101 (100 MHz, single channel)	DG5101
	DG5072 (70MHz, dual-channel)	DG5072
	DG5071 (70MHz, single-channel)	DG5071
Standard	Power Cord	-
Accessories	USB Cable	CB-USB
	BNC Cable (1 meter)	CB-BNC-BNC-1
	Quick Guide (Hard Copy)	-
	Resource CD (including User's Guide and Application Software)	-
	SMB(F) to BNC(M) Cable (1 meter)	CB-SMB(F)-BNC(M)-1
Options	DG5 PC Software	Ultra Station
	Frequency Hopping Module	DG5-FH
	Logic Signal Output Module	DG-POD-A
Optional Accessories	Power Amplifier	PA1011
	SMB(F) to SMB(F) Cable (1 meter)	CB-SMB(F)-SMB(F)-1
	SMB(F) to BNC(F) Cable (1 meter)	CB-SMB(F)-BNC(F)-1
	40 dB Attenuator	ATT-40dB
	Rack Mount Kit	RMK-DG-5

DG4000 Series Function/Arbitrary Waveform Generators



► Features and Benefits

- 160 MHz, 100 MHz, 60 MHz maximum output frequency
- 500MSa/s sample rate, 14 bits vertical resolution
- Dual Channel Outputs With Identical Performance
- 2ppm High-frequency Stability
- -115dBc/Hz Low Phase Noise
- Versatile Analog and Digital Modulation functions
- Built-in 150 Waveforms
- Built-in 7digits/s, 200MHz Counter
- 16th Harmonic Generation Function(Std.)
- Powerful Waveform Editing PC Software
- Connectivity: USB Host & Device, LAN
- 7 Inch LCD Display (800x480)

► Key Specifications

All the specifications can be guaranteed if the following two conditions are met unless where noted.

- The generator is within the calibration and has performed self-calibration.
- The generator has been working continuously for 30 minutes at specified temperature (18°C ~ 28°C).

All the specifications are guaranteed unless those marked with "typical".

Model	DG4162	DG4102	DG4062
Channel	2	2	2
Maximum Frequency	160MHz	100 MHz	60 MHz
Sample Rate	500 MSa/s		

Waveforms			
Standard waveforms	Sine, Square, Ramp, Pulse, Noise, Harmonics		
Arbitrary Waveforms	150 kinds, including Sinc, Exponential Rise, Exponential Fall, ECG, Gauss, HaverSine, Lorentz, Dual-Tone, DC, etc.		
Frequency Characteristics			
Sine	1 μHz to 160 MHz	1 μHz to 100 MHz	1 μHz to 60 MHz
Square	1 μHz to 50 MHz	1 μHz to 40 MHz	1 μHz to 25 MHz
Ramp	1 μHz to 4MHz	1 μHz to 3 MHz	1 μHz to 1 MHz
Pulse	1 μHz to 40 MHz	1 μHz to 25 MHz	1 μHz to 15 MHz
Harmonic	1 uHz to 80 MHz	1 uHz to 50 MHz	1 uHz to 30 MHz
Noise (-3dB)	120 MHz Bandwidth	80 MHz Bandwidth	60 MHz Bandwidth
Arb	1 μHz to 40 MHz	1 μHz to 25 MHz	1 μHz to 15 MHz
Resolution	1 μHz		
Accuracy	±2ppm, 18 °C to 28 °C		

Sine Wave Spectrum Purity	
Harmonic Distortion	Typical (0dBm)
	DC-1MHz: <-60dBc
	1MHz-10MHz: <-55dBc
	10MHz-100MHz: <-50dBc
Total Harmonic Distortion	100MHz-160MHz: <-40dBc
	<0.1%(10Hz-20kHz,0dBm)
Spurious (non-harmonic)	Typical(0dBm)
	≤10MHz <-65dBc
Phase Noise	>10MHz <-65dBc+6dB/octave
	Typical (0 dBm, 10 kHz deviation)
	10 MHz: ≤-115 dBc/Hz

Signal Characteristics			
Square	Rise/Fall Time	Typical (1Vpp)	Typical (1Vpp)
		<8 ns	<10 ns
Overshoot	Typical (1Vpp)	<3%	
		<3%	
Duty Cycle	≤10 MHz:	20.0% to 80.0%	
	10 MHz-40 MHz:	40.0% to 60.0%	
	>40 MHz:	50.0% (fixed)	
Non-symmetry	1% of period + 5 ns		
Jitter (rms)	Typical,(1MHz,1Vpp,50Ω)		
	≤5MHz	2ppm+500 ps	
	> 5MHz	500ps	

Arb			
Waveform Length	16k points		
Vertical Resolution	14 bits		
Sample Rate	500M Sa/s		
Harmonic			
Harmonic Order	≤16		
Harmonic Type	Even, Odd, All, User		
Harmonic Amplitude	can be set for all the harmonics		
Harmonic Phase	can be set for all the harmonics		
Output Characteristics			
Amplitude (into 50 Ω)			
Range	≤20MHz: 1mVpp to 10Vpp ≤60MHz: 1mVpp to 5Vpp ≤120MHz: 1mVpp to 2.5Vpp ≤160MHz: 1mVpp to 1Vpp	≤20MHz: 1mVpp to 10Vpp ≤60MHz: 1mVpp to 5Vpp ≤100MHz: 1mVpp to 2.5Vpp	≤20MHz: 1mVpp to 10Vpp ≤60MHz: 1mVpp to 5Vpp
Accuracy	Typical (1kHz Sine, 0V Offset, >10mVpp, Auto) ± 1% of setting ± 2mVpp		
Amplitude Flatness (relative 1kHz, 500mVpp Sine wave, 50Ω)	Typical ≤10MHz: ±0.1dB ≤60MHz: ±0.2dB ≤100MHz: ±0.4dB ≤160MHz: ±0.8dB	Typical ≤10MHz: ±0.1dB ≤60MHz: ±0.2dB ≤100MHz: ±0.4dB	Typical ≤10MHz: ±0.1dB ≤60MHz: ±0.2dB
Units	Vpp, Vrms, dBm		
Protection	Short-circuit protection, automatically disables main output when overload relay		
Modulation Characteristics			
Modulation Types	AM, FM, PM, ASK, FSK, PSK, BPSK, QPSK, 3FSK, 4FSK, OSK, PWM		
Burst Characteristics			
Carrier Waveforms	Sine, Square, Ramp, Pulse, Noise, Arb (except DC)		
Carrier Frequency	2mHz to 100 MHz	2mHz to 100 MHz	2mHz to 60 MHz
Burst Count	1 to 1 000 000 or Infinite		
Start/Stop Phase	0° to 360°		
Internal Period	2μs to 500 s		
Gated Source	External Trigger		
Trigger Source	Internal, External or Manual		
Trigger Delay	0 ns to 85 s		
Counter Specifications			
Function	Frequency, Period, Positive/Negative Pulse Width, Duty Cycle		
Freqcy Resolution	7 digits/second		
Frequency Range	1uHz to 200MHz		

► Ordering Information

	Description	Order Number
Model	DG4162 (160 MHz, dual-channel)	DG4162
	DG4102 (100 MHz, dual-channel)	DG4102
	DG4062 (60 MHz, dual-channel)	DG4062
Standard	Power Cord	-
Accessories	USB Cable	CB-USB
	BNC Cable (1 meter)	CB-BNC-BNC-1
	Quick Guide (Hard Copy)	-
	Resource CD (including User's Guide and Application Software)	-
	DG4 PC Software	Ultra Station
Optional Accessories	40 dB Attenuator	ATT-40dB
	Rack Mount Kit	RMK-DG-4

DG1000 Series Function/Arbitrary Waveform Generators



► Features and Benefits

- Max. Output frequency 25 MHz
- Dual Channel Output
- 100MSa/s Sample Rate
- 14bits Vertical Resolution
- Built-in 6digits/s, 200MHz Counter
- Built-in 48 Waveforms
- Powerful Waveform Editing PC Software
- Connectivity: USB Device and USB Host

► Models and Key Specifications

Models	DG1022	DG1022A
Frequency Characteristics		
Sine	1 μ Hz ~ 20MHz	1 μ Hz ~ 25MHz
Square	1 μ Hz ~ 5MHz	1 μ Hz ~ 5MHz
Pulse	500 μ Hz ~ 3MHz	500 μ Hz ~ 5MHz
Ramp	1 μ Hz ~ 150kHz	1 μ Hz ~ 500kHz
Noise(-3dB)	5MHz BW (-3dB)	5MHz BW (-3dB)
Arb	1 μ Hz ~ 5MHz	1 μ Hz ~ 5MHz
Resolution	1 μ Hz	

Sine Wave Spectrum Purity

Harmonic Distortion	Ch1		Ch2	
	≤ 1 VPP	> 1 VPP	≤ 1 VPP	> 1 VPP
DC-1MHz	-45dBc	-45dBc	-45dBc	-45dBc
1MHz-5MHz	-45dBc	-40dBc	-45dBc	-40dBc
5MHz-20MHz	-45dBc	-35dBc	-45dBc	-35dBc
Total Harmonic Distortion	DC ~ 20 kHz, 1VPP <0.2%			
Spurious (non-harmonic)	DC ~ 1 MHz < -70 dBc			
Phase Noise	1 MHz ~ 10 MHz < -70 dBc + 6 dB/octave			
	10kHz Offset, -108 dBc / Hz, typ.			

Signal Characteristics

Rise/Fall Time	< 20 ns (10% ~ 90%, typ, 1kHz, 1 VPP)	
Overshoot	< 5% (Typ., 1kHz, 1 VPP)	
Duty Cycle	1 μ Hz~ 3MHz	20% ~ 80%
	3MHz (Excluding) ~ 4MHz	40% ~ 60%
	4MHz (Excluding) ~ 5MHz	50%
Non-symmetry (@50% Duty cycle)	1% of period + 20ns (typ., 1kHz, 1 VPP)	

Output Characteristics

	DG1022		DG1022A	
Amplitude (50 Ω)	Ch1	Ch2	Ch1	Ch2
	2 mVPP ~ 10 VPP	2 mVPP ~ 3 VPP	≤ 20 MHz: 2 mVPP ~ 10 VPP; > 20 MHz: 2 mVPP ~ 5 VPP;	2 mVPP ~ 3 VPP

Waveform Output

	Ch1	Ch2
Impedance	50 Ω typ.	50 Ω typ.
Protection ²⁾	Short-circuit protection; auto disable if over loading	Short-circuit protection
Modulation Mode	AM、FM、PM、FSK-internal or external	

Counter Specification

Function	Frequency, period, positive/negative Pulse width, Duty cycle
Frequency range	Single channel: 100 mHz ~ 200 MHz
Frequency resolution	6 Digits/Second

DM3068 6½ Digital Multimeter



► Features and Benefits

- 2,200,000 Counts of Resolution
- 0.0035% DC Voltage Accuracy
- Up to 10krdgs/s Measurement Speed
- Max. 10A Current Measurement Range
- Dual Measurements Display
- Real-time Trend and Histogram display
- Display Functions
- User Definable Any-sensor function with UltraSensor PC sw
- Command compatible with main stream DMMs
- Connectivity: USB Host&Device, RS-232, GPIB, LAN (LXI-C)

► Key Specifications

DC Characteristics

Accuracy Specifications: ± (% of reading + % of range)^[1]

Function	Range ^[2]	Test Current or Burden Voltage	24 Hour ^[3] T _{CAL} °C ± 1 °C	90 Day T _{CAL} °C ± 5 °C	1 Year T _{CAL} °C ± 5 °C	Temperature Coefficient 0 °C to (T _{CAL} °C - 5 °C) (T _{CAL} °C + 5 °C) to 50 °C
DC Voltage	200.0000mV		0.0020 + 0.0020	0.0030 + 0.0025	0.0040 + 0.0025	0.0005 + 0.0005
	2.000000V		0.0015 + 0.0005	0.0020 + 0.0006	0.0035 + 0.0006	0.0005 + 0.0001
	20.00000V		0.0020 + 0.0004	0.0030 + 0.0005	0.0040 + 0.0005	0.0005 + 0.0001
	200.0000V		0.0020 + 0.0006	0.0040 + 0.0006	0.0050 + 0.0006	0.0005 + 0.0001
	1000.000V ^[4]		0.0020 + 0.0006	0.0040 + 0.0010	0.0055 + 0.0010	0.0005 + 0.0001
DC Current	200.0000uA	<0.03V	0.010 + 0.012	0.040 + 0.015	0.050 + 0.015	0.0020 + 0.0030
	2.000000mA	<0.25V	0.007 + 0.003	0.030 + 0.003	0.050 + 0.003	0.0020 + 0.0005
	20.00000mA	<0.07V	0.007 + 0.012	0.030 + 0.015	0.050 + 0.015	0.0020 + 0.0020
	200.0000mA	<0.7V	0.010 + 0.002	0.030 + 0.003	0.050 + 0.003	0.0020 + 0.0005
	2.000000A	<0.12V	0.050 + 0.020	0.080 + 0.020	0.100 + 0.020	0.0050 + 0.0010
Resistance ^[6]	10.00000A ^[5]	<0.6V	0.100 + 0.010	0.120 + 0.010	0.150 + 0.010	0.0050 + 0.0020
	200.0000Ω	1mA	0.0030 + 0.0030	0.008 + 0.004	0.010 + 0.004	0.0006 + 0.0005
	2.000000kΩ	1mA	0.0020 + 0.0005	0.008 + 0.001	0.010 + 0.001	0.0006 + 0.0001
	20.00000kΩ	100uA	0.0020 + 0.0005	0.008 + 0.001	0.010 + 0.001	0.0006 + 0.0001
	200.0000kΩ	10uA	0.0020 + 0.0005	0.008 + 0.001	0.010 + 0.001	0.0006 + 0.0001
Diode Test	1.000000MΩ	2uA	0.002 + 0.001	0.010 + 0.001	0.012 + 0.001	0.0010 + 0.0002
	10.00000MΩ	200nA	0.015 + 0.001	0.030 + 0.001	0.040 + 0.001	0.0030 + 0.0004
	100.0000MΩ	200nA 10MΩ	0.300 + 0.010	0.800 + 0.010	0.800 + 0.010	0.1500 + 0.0002
Continuity Test	2.0000V ^[7]	1mA	0.002 + 0.010	0.008 + 0.020	0.010 + 0.020	0.0010 + 0.0020
	2000.0Ω	1mA	0.002 + 0.010	0.008 + 0.020	0.010 + 0.020	0.0010 + 0.0020

[1] Specifications are for 90-minute warm-up and 100NPLC integration time. For integration time <100NPLC, add the appropriate "RMS Noise Adder" listed in the following table.

[2] 10% overrange on all ranges except DCV 1000V and DCI 10A ranges.

[3] Relative to calibration standards.

[4] For each additional volt over ± 500 V, add 0.03mV error.

[5] For continuous current > 7A DC or 7AAC RMS, 30 seconds ON and 30 seconds OFF.

[6] Specifications are for 4-wire resistance measurement or 2-wire resistance measurement using REL operation. Without REL operation, add 0.2 Ω additional error in 2-wire resistance measurement.

[7] Accuracy specifications for the voltage measured at the input terminal only. 1 mA test current is typical. Variation in the current source will create some variation in the voltage drop across a diode junction.

AC Characteristics

Accuracy Specifications: ±(% of reading + % of range)^[1]

Function	Range ^[2]	Frequency Range	24 Hour ^[3] T _{CAL} °C ± 1 °C	90 Day T _{CAL} °C ± 5 °C	1 Year T _{CAL} °C ± 5 °C	Temperature Coefficient 0 °C to (T _{CAL} °C - 5 °C) (T _{CAL} °C + 5 °C) to 50 °C
True RMS AC Voltage ^[4]	200.0000 mV	3Hz - 5Hz	1.00 + 0.03	1.00 + 0.04	1.00 + 0.04	0.100 + 0.004
		5Hz - 10Hz	0.35 + 0.03	0.35 + 0.04	0.35 + 0.04	0.035 + 0.004
		10Hz - 20kHz	0.04 + 0.03	0.05 + 0.04	0.06 + 0.04	0.005 + 0.004
		20kHz - 50kHz	0.10 + 0.05	0.11 + 0.05	0.12 + 0.05	0.011 + 0.005
		50kHz - 100kHz	0.55 + 0.08	0.60 + 0.08	0.60 + 0.08	0.060 + 0.008
		100kHz - 300kHz	4.00 + 0.50	4.00 + 0.50	4.00 + 0.50	0.20 + 0.02
	2.000000 V	3Hz - 5Hz	1.00 + 0.02	1.00 + 0.03	1.00 + 0.03	0.100 + 0.003
		5Hz - 10 Hz	0.35 + 0.02	0.35 + 0.03	0.35 + 0.03	0.035 + 0.003
		10Hz - 20kHz	0.04 + 0.02	0.05 + 0.03	0.06 + 0.03	0.005 + 0.003
		20kHz - 50kHz	0.10 + 0.04	0.11 + 0.05	0.12 + 0.05	0.011 + 0.005
		50kHz - 100kHz	0.55 + 0.08	0.60 + 0.08	0.60 + 0.08	0.060 + 0.008
		100kHz - 300kHz	4.00 + 0.50	4.00 + 0.50	4.00 + 0.50	0.20 + 0.02
20.00000 V	3Hz - 5Hz	1.00 + 0.03	1.00 + 0.04	1.00 + 0.04	0.100 + 0.004	
	5Hz - 10Hz	0.35 + 0.03	0.35 + 0.04	0.35 + 0.04	0.035 + 0.004	
	10Hz - 20kHz	0.04 + 0.04	0.07 + 0.04	0.08 + 0.04	0.008 + 0.004	
	20kHz - 50kHz	0.10 + 0.05	0.12 + 0.05	0.15 + 0.05	0.012 + 0.005	

		50kHz - 100kHz	0.55 + 0.08	0.60 + 0.08	0.60 + 0.08	0.060 + 0.008
		100kHz - 300kHz	4.00 + 0.50	4.00 + 0.50	4.00 + 0.50	0.20 + 0.02
	200.0000 V	3Hz - 5Hz	1.00 + 0.02	1.00 + 0.03	1.00 + 0.03	0.100 + 0.003
		5Hz - 10Hz	0.35 + 0.02	0.35 + 0.03	0.35 + 0.03	0.035 + 0.003
		10Hz - 20kHz	0.04 + 0.02	0.07 + 0.03	0.08 + 0.03	0.008 + 0.003
		20kHz - 50kHz	0.10 + 0.04	0.12 + 0.05	0.15 + 0.05	0.012 + 0.005
		50kHz - 100kHz	0.55 + 0.08	0.60 + 0.08	0.60 + 0.08	0.060 + 0.008
		100kHz - 300kHz	4.0 + 0.50	4.0 + 0.50	4.0 + 0.50	0.20 + 0.02
	750.000 V ^[5]	3Hz - 5Hz	1.00 + 0.02	1.00 + 0.03	1.00 + 0.03	0.100 + 0.003
		5Hz - 10Hz	0.35 + 0.02	0.35 + 0.03	0.35 + 0.03	0.035 + 0.003
		10Hz - 20kHz	0.04 + 0.02	0.07 + 0.03	0.08 + 0.03	0.008 + 0.003
		20kHz - 50kHz	0.10 + 0.04	0.12 + 0.05	0.15 + 0.05	0.012 + 0.005
		50kHz - 100kHz	0.55 + 0.08	0.60 + 0.08	0.60 + 0.08	0.060 + 0.008
		100kHz - 300kHz	4.0 + 0.50	4.0 + 0.50	4.0 + 0.50	0.20 + 0.02
True RMS AC Current ^[6]	200.0000 uA	3Hz - 5Hz	1.10 + 0.06	1.10 + 0.06	1.10 + 0.06	0.200 + 0.006
		5Hz - 10Hz	0.35 + 0.06	0.35 + 0.06	0.35 + 0.06	0.100 + 0.006
		10Hz - 5kHz	0.15 + 0.06	0.15 + 0.06	0.15 + 0.06	0.015 + 0.006
		5kHz - 10kHz	0.35 + 0.70	0.35 + 0.70	0.35 + 0.70	0.030 + 0.006
	2.000000 mA	3Hz - 5Hz	1.00 + 0.04	1.00 + 0.04	1.00 + 0.04	0.100 + 0.006
		5Hz - 10Hz	0.30 + 0.04	0.30 + 0.04	0.30 + 0.04	0.035 + 0.006
		10Hz - 5kHz	0.12 + 0.04	0.12 + 0.04	0.12 + 0.04	0.015 + 0.006
		5kHz - 10kHz	0.20 + 0.25	0.20 + 0.25	0.20 + 0.25	0.030 + 0.006
	20.00000 mA	3Hz - 5Hz	1.10 + 0.06	1.10 + 0.06	1.10 + 0.06	0.200 + 0.006
		5Hz - 10Hz	0.35 + 0.06	0.35 + 0.06	0.35 + 0.06	0.100 + 0.006
		10Hz - 5kHz	0.15 + 0.06	0.15 + 0.06	0.15 + 0.06	0.015 + 0.006
		5kHz - 10kHz	0.35 + 0.70	0.35 + 0.70	0.35 + 0.70	0.030 + 0.006
	200.0000 mA	3Hz - 5Hz	1.00 + 0.04	1.00 + 0.04	1.00 + 0.04	0.100 + 0.006
		5Hz - 10Hz	0.30 + 0.04	0.30 + 0.04	0.30 + 0.04	0.035 + 0.006
		10Hz - 5kHz	0.10 + 0.04	0.10 + 0.04	0.10 + 0.04	0.015 + 0.006
		5kHz - 10kHz	0.20 + 0.25	0.20 + 0.25	0.20 + 0.25	0.030 + 0.006
	2.000000 A	3Hz - 5Hz	1.10 + 0.06	1.10 + 0.06	1.10 + 0.06	0.100 + 0.006
		5Hz - 10Hz	0.35 + 0.06	0.35 + 0.06	0.35 + 0.06	0.035 + 0.006
		10Hz - 5kHz	0.15 + 0.06	0.15 + 0.06	0.15 + 0.06	0.015 + 0.006
		5kHz - 10kHz	0.35 + 0.70	0.35 + 0.70	0.35 + 0.70	0.030 + 0.006
	10.00000 A ^[6]	3Hz - 5Hz	1.10 + 0.08	1.10 + 0.10	1.10 + 0.10	0.100 + 0.008
		5Hz - 10Hz	0.35 + 0.08	0.35 + 0.10	0.35 + 0.10	0.035 + 0.008
		10Hz - 5kHz	0.15 + 0.08	0.15 + 0.10	0.15 + 0.10	0.015 + 0.008

Additional Low Frequency Errors (% of reading)

Additional Crest Factor Errors (non-sinewave)^[7]

Frequency	AC Filter			Crest Factor	Error (% of reading)
	Slow	Medium	Fast		
10Hz - 20Hz	0	0.74	--	1 - 2	0.05
20Hz - 40Hz	0	0.22	--	2 - 3	0.2
40Hz - 100Hz	0	0.06	0.73	3 - 4	0.4
100Hz - 200Hz	0	0.01	0.22	4 - 5	0.5
200Hz - 1kHz	0	0	0.18		
>1kHz	0	0	0		

[1] Specifications are for 90-minute warm-up, slow ac filter and sinewave input.

[2] 10% overrange on all ranges except ACV 750 V and ACI 10 A ranges.

[3] Relative to calibration standards.

[4] Specifications are for sinewave input >5% of range. For inputs within 1% and 5% of range and <50 kHz, add 0.1% of range additional error. For 50kHz to 100kHz, add 0.13% of range additional error.

[5] ACV 750 range limited to 8x10⁷ Volt-Hz. For input over 300V rms, add 0.7mV error for each additional volt.

[6] For continuous current > DC 7A or AC RMS 7A, 30 seconds ON and 30 seconds OFF.

[7] For frequency below 100 Hz, the specification of slow filter is only for sinewave input.

[8] Specifications are for sinewave input >5% of range. For inputs within 1% to 5% of range, add 0.1% of range additional error. Specifications are typical values for 200uA and 2mA, 2A and 10A ranges when frequency >1kHz.

► Ordering Information

	Description	Order Number
Model	DM3068:6½ digits	DM3068
Standard Accessories	Power Cord conforming to the standard of the country USB Cable	CB-USB-150
	Two Test Leads (black and red) Two Alligator Clips (black and red)	
	Quick Guide Four Spare Fuses Resource CD (User's Guide and Application Software)	
Optional Accessories	Rack Mount Kit Kelvin Test Clips	RM-DM-3

NOTE: All the standard or optional accessories can be ordered from you local RIGOL Office.

DM3058/DM3058E 5½ Digital Multimeter



► Features and Benefits

- 240,000 Counts of Resolution
- 0.015% DC Voltage Accuracy
- Up to 123krdgs/s Measurement Speed
- Max. 10A Current Measurement Range
- Dual Measurements Display
- Real-time Trend and Histogram display
- User Definable Any-sensor function with UltraSensor PC sw
- Ultra View PC software(Optional)
- Command compatible with main stream DMMs
- Support Web remote control
- Connectivity: USB Host&Device,RS-232,GPIB(DM3058),LAN(DM3058)

► Key Specifications

DC Characteristics

Accuracy Specifications: \pm (% of reading + % of range)^[1]

Function	Range ^[2]	Test Current or Burden Voltage	1Year 23°C \pm 5°C	T Temperature Coefficient 0°C-18°C 28°C-50°C
DC Voltage	200.000 mV		0.015 + 0.004	0.0015 + 0.0005
	2.00000 V		0.015 + 0.003	0.0010 + 0.0005
	20.0000 V		0.015 + 0.004	0.0020 + 0.0005
	200.000 V		0.015 + 0.003	0.0015 + 0.0005
DC Current	1000.00 V[4]		0.015 + 0.003	0.0015 + 0.0005
	200.000 μ A	<8 mV	0.055 + 0.005	0.003 + 0.001
	2.00000 mA	<80 mV	0.055 + 0.005	0.002 + 0.001
	20.0000 mA	<0.05 V	0.095 + 0.020	0.008 + 0.001
	200.000 mA	<0.5 V	0.070 + 0.008	0.005 + 0.001
Resistance ^[4]	2.00000 A	<0.1 V	0.170 + 0.020	0.013 + 0.001
	10.0000 A[5]	<0.3 V	0.250 + 0.010	0.008 + 0.001
	200.000 Ω	1 mA	0.030 + 0.005	0.0030 + 0.0006
	2.00000 k Ω	1 mA	0.020 + 0.003	0.0030 + 0.0005
	20.0000 k Ω	100 μ A	0.020 + 0.003	0.0030 + 0.0005
	200.000 k Ω	10 μ A	0.020 + 0.003	0.0030 + 0.0005
Diode Test	2.00000 M Ω	1 μ A	0.040 + 0.004	0.0040 + 0.0005
	10.0000 M Ω	200 nA	0.250 + 0.003	0.0100 + 0.0005
Continuity Test	100.000 M Ω	200 nA 10 M Ω	1.75 + 0.004	0.2000 + 0.0005
	2.0000 V[6]	1 mA	0.05 + 0.01	0.0050 + 0.0005
Continuity Test	2000 Ω	1 mA	0.05 + 0.01	0.0050 + 0.0005

Remarks:

[1] Specifications are for 0.5 hour warm-up, "Slow" measure and calibration temperature 18°C - 28°C.

[2] 20% over range on all ranges except for DCV 1000 V, ACV 750 V, DCI 10 A and ACI 10 A.

[3] Specifications are for 4-wire measure or 2-wire measure under "REF" operation. \pm 0.2 Ω of extra errors will be generated if perform 2-wire measure without "REF" operation.

[4] Plus 0.02 mV of error per 1 V after the first \pm 500 VDC.

[5] 30 seconds OFF after 30 seconds ON is recommend for the continuous current that higher than DC 7 A or AC RMS 7 A.

Accuracy specifications are only for voltage measuring at input terminal. The typical value of current under measure is 1 mA. Voltage drop at the diode junction may vary with current supply.

AC Characteristics

Accuracy Specifications: \pm (% of reading + % of range)^[1]

Function	Range ^[2]	Frequency Range	1 Year 23°C \pm 5°C	Temperature Coefficient 0°C-18°C 28°C-50°C
True RMS AC Voltage ^[3]	200.000 mV	20 Hz – 45 Hz	1.5 + 0.10	0.01 + 0.005
		45 Hz – 20 kHz	0.2 + 0.05	0.01 + 0.005
		20 kHz – 50 kHz	1.0 + 0.05	0.01 + 0.005
		50 kHz – 100 kHz	3.0 + 0.05	0.05 + 0.010
	2.00000 V	20 Hz – 45 Hz	1.5 + 0.10	0.01 + 0.005
		45 Hz – 20 kHz	0.2 + 0.05	0.01 + 0.005
		20 kHz – 50 kHz	1.0 + 0.05	0.01 + 0.005
		50 kHz – 100 kHz	3.0 + 0.05	0.05 + 0.010
	20.0000 V	20 Hz – 45 Hz	1.5 + 0.10	0.01 + 0.005
		45 Hz – 20 kHz	0.2 + 0.05	0.01 + 0.005
		20 kHz – 50 kHz	1.0 + 0.05	0.01 + 0.005
		50 kHz – 100 kHz	3.0 + 0.05	0.05 + 0.010
200.000 V	20 Hz – 45 Hz	1.5 + 0.10	0.01 + 0.005	
	45 Hz – 20 kHz	0.2 + 0.05	0.01 + 0.005	
	20 Hz – 45 Hz	1.5 + 0.10	0.01 + 0.005	

		20 kHz – 50 kHz	0.01 + 0.005	0.01 + 0.005
		50 kHz – 100 kHz	0.05 + 0.010	0.05 + 0.010
	750.000 V	20 Hz – 45 Hz	0.01 + 0.005	0.01 + 0.005
		45 Hz – 20 kHz	0.01 + 0.005	0.01 + 0.005
		20 kHz – 50 kHz	0.01 + 0.005	0.01 + 0.005
		50 kHz – 100 kHz	0.05 + 0.010	0.05 + 0.010
True RMS AC Voltage ^[5]	20.0000 mA	20Hz – 45 Hz	0.015 + 0.015	0.015 + 0.015
		45 Hz - 2 kHz	0.015 + 0.006	0.015 + 0.006
		2 kHz - 10 kHz	0.015 + 0.006	0.015 + 0.006
	200.000 mA	20 Hz - 45 Hz	0.015 + 0.005	0.015 + 0.005
		45 Hz – 2 kHz	0.015 + 0.005	0.015 + 0.005
		2 kHz - 10 kHz	0.015 + 0.005	0.015 + 0.005
	2.00000 A	20 Hz – 45 Hz	0.015 + 0.005	0.015 + 0.005
		45 Hz - 2 kHz	0.015 + 0.005	0.015 + 0.005
		2 kHz – 10 kHz	0.015 + 0.005	0.015 + 0.005
	10.0000 A ^[5]	20 Hz – 45 Hz	0.015 + 0.005	0.015 + 0.005
		45 Hz - 2 kHz	0.015 + 0.005	0.015 + 0.005
		2 kHz – 5 kHz	0.015 + 0.005	0.015 + 0.005

Additional wave crest factor error (not Sine)^[6]

Wave crest coefficient	Error (% range)
1 - 2	0.05
2 - 3	0.2

Remarks:

- [1] Specifications are for 0.5 hour warm-up, "Slow" measure and calibration temperature 18°C - 28°C.
- [2] 20% over range on all ranges except for DCV 1000 V, ACV 750 V, DCI 10 A and ACI 10 A.
- [3] Specifications are for amplitude of sine wave input >5% of range. 750 V range limited to 8x10⁷ Volt-Hz. For inputs from 1% to 5% of range and <50 kHz, add 0.1% of range extra error. For 50 kHz to 100 kHz, add 0.13%.

- [4] Specifications are for sine wave input >5% of range. 0.1% errors will be added when the range of input sine wave is 1% ~ 5%.
- [5] 30 seconds OFF after 30 seconds ON is recommend for the continuous current that higher than DC 7 A or AC RMS 7 A.
- [6] For frequency<100 Hz.

► key features



Pass/Fail Test



Dual Display

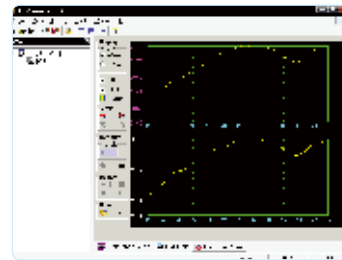

UltraSensor Software

► Ordering Information

Model	Description	Order Number
	DM3058:5½ digits	DM3058
	DM3058E:5½ digits,without GPIB,LAN	DM3058E
Standard Accessories	Power Cord conforming to the standard of the country	
	USB Cable	CB-USB-150
	Two Test Leads (black and red)	
	Two Alligator Clips (black and red)	
	Quick Guide	
	Four Spare Fuses	
	Resource CD (User's Guide and Application Software)	
Optional Accessories	Rack Mount Kit	RM-DM-3
	Kelvin Test Clips	
	UltraView PC control and data acquisition Software	UltraView

DP1000 Series Programmable DC Power Supply



- **Features and Benefits**
- DP1116A: 1 Output, DP1308A:3 Outputs
 - Low Ripple Noise: <350 uVrms
 - Excellent Power Regulation Rate and Load Regulation Rate
 - Fast Transient Response Time: <50us
 - Channel isolation and Voltage tracking(DP1308A)
 - Standard OVP/OCP/OTP protection functions
 - Remote Sense Capability(DP1116A)
 - Standard Timing function
 - Built in V,A,W measurements and waveform display
 - Independent control for each channel
 - 4.3 Inch TFT Display
 - Connectivity: USB Host&Device, LAN, GPIB

► **Features and Benefits**



DP1308A Setup Interface



DP1116A Setup Interface



Timing Output function

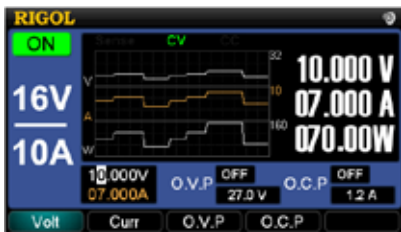

V,A,W measurements & waveform display

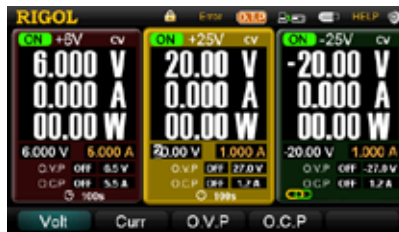

Standard OVP/OCP/OTP protection



Interface Setup



V/A/W Classic display



Store and recall system setups



On-line Help

► Key Specifications

Model	DP1116A		DP1308A		
Output Ranges/Channels	16V/10A	32V/5A	+6 V	+25 V	-25 V
DC Output (0°C – 40°C)					
Voltage	0 to 16 V	0 to 32 V	0 to +6V	0 to +25 V	0 to -25 V
Current	0 to 10 A	0 to 5 A	0 to 5 A	0 to 1 A	0 to 1 A
Overvoltage Protection	0.1 V to 35.2 V		0.1 V to 6.5 V	0.1 V to 27 V	-0.1 V to -27 V
Overcurrent Protection	0.1 A to 11 A		0.1 A to 5.5 A	0.1 A to 1.2 A	0.1 A to 1.2 A
Load Regulation± (output percentage + offset)					
Voltage	< 0.01% + 2 mV				
Current	< 0.005% + 250 µA		< 0.01% + 250 µA		
Line Regulation± (output percentage + offset)					
Voltage	< 0.01% + 2 mV				
Current	< 0.01% + 250 µA				
Ripple and Noise (20 Hz - 20 MHz)					
Normal Mode Voltage	< 350 µV rms/3 mVpp		< 350 µV rms/2 mVpp		
Normal Mode Current	< 2 mA rms		< 2 mA rms	< 500 µA rms	
Common Mode Current	-		<1.5 µA rms		
Accuracy 12 Months ^[1] (25°C ±5°C)±(output percentage + offset)					
Programming	Voltage	0.05% + 10 mV	0.1% + 5 mV	0.05% + 20 mV	
	Current	0.2% + 10 mA	0.2% + 10 mA	0.15% + 4 mA	
Read Back	Voltage	0.05% + 5 mV	0.1% + 5 mV	0.05% + 10 mV	
	Current	0.15% + 5 mA	0.2% + 10 mA	0.15% + 4 mA	
Resolution					
Programming	1 mV/1 mA		0.5 mV/0.5 mA	1.5 mV/0.1 mA	
Read Back	1 mV/1 mA		0.5 mV/0.5 mA	1.5 mV/0.1 mA	
Meter	1 mV/1 mA		1 mV/1 mA	10 mV/1 mA	
Transient Response Time					
Less than 50 µs is spent on recovering the voltage within 15 mV during the output current changes from full load to half load or half to full.					
Command Processing Time ^[2]					
< 50 ms					
Temperature Coefficient per °C (output percentage + offset)					
Voltage	0.01% + 3 mV		0.01% + 2 mV	0.01% + 3 mV	
Current	0.02% + 5 mA		0.02% + 3 mA	0.01% + 0.5 mA	
Stability ^[3] , ±(output percentage + offset)					
Voltage	0.02% + 1 mV		0.03% + 1 mV	0.02% + 2 mV	
Current	0.1% + 1 mA		0.1% + 3 mA	0.05% + 1 mA	
Machine					
Dimension	235 mm (W) x 155 mm (H) x 384 mm (D)				
Weight	11 kg		8.5 kg		

Remarks:

[1]Specifications are for one hour warm-up and at 25°C .

[2]The maximum time required for regulating corresponding output when received APPLY and SOURce commands.

[3]The variation of output within 8 hours after warm-up 30 minutes and both the load circuit and environment temperature are in constant conditions.

► Ordering Information

	Description	Order Number
Model	Programmable DC Power (Single Channel)	DP1116A
	Programmable DC Power (Triple-Channel)	DP1308A
Standard Accessories	A Power cord	
	A USB data cable	
	Two shorted devices (only for DP1116A)	
	A CD (including User's Guide and Programming Guide)	
	Four fuses (two of 250 V/T2.5 A and two of 250 V/T4 A): DP1116A	
	Four fuses (two of 250 V/T3 A and two of 250 V/T2 A): DP1308A	
	Rack Mount Kit	RM-DP-1
	An INSTRUCTION	

DP800 Series Programmable DC Power Supply



► Features and Benefits

- 3 Outputs, Max. Power up to 195W
- Low Ripple Noise: <math><350 \mu\text{Vrms}/2\text{mVpp}</math>
- Excellent Power Regulation Rate and Load Regulation Rate
- Fast Transient Response Time: <math><50\mu\text{s}</math>
- Channel isolation: CH1 || CH2, CH3
- Standard OVP/OCP/OTP protection functions
- Standard Timing function
- Built in V,A,W measurements and waveform display
- Support Output Delay, Analysis, Monitor, Preset functions
- Independent control for each channel
- 3.5 Inch TFT Display
- Connectivity: USB Host& Device, LAN, RS232,Digital IO, Support USB-GPIB

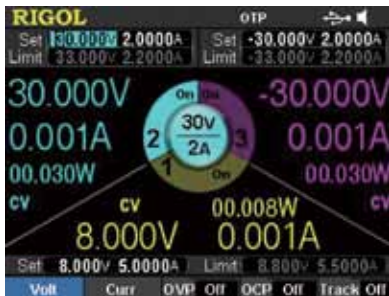

DP831A GUI

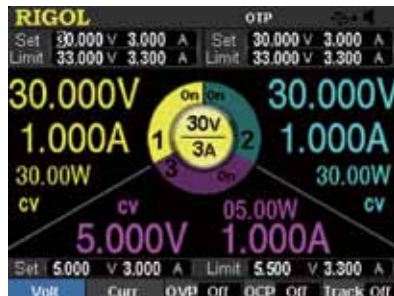

DP832A GUI



DP832 GUI



Timing Output



V/A/W Display



Output Analysis Function



Monitor Setup



Trigger In/Out

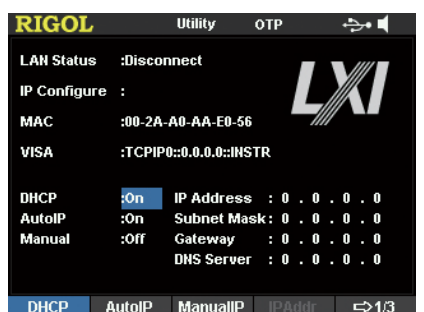

LAN Setup

► Key Specifications

Model	DP832A	DP832	DP831A
Channels	3		
DC Outputs	CH1: 0 ~ 30V/0 ~ 3A CH2: 0 ~ 30V/0 ~ 3A CH3: 0 ~ 5V/0 ~ 3A		CH1: 0 ~ 8V/0 ~ 5A CH2: 0 ~ +30V/0 ~ 2A CH3: -30 ~ 0V/0 ~ 2A
Load Regulation	Voltage: $\leq 0.01\% + 2\text{mV}$; Current: $\leq 0.01\% + 250\mu\text{A}$		
Line Regulation	Voltage: $\leq 0.01\% + 2\text{mV}$; Current: $\leq 0.01\% + 250\mu\text{A}$		
Ripple and Noise	Normal Mode Voltage: $\leq 350\mu\text{Vrms} / 2\text{mVpp}(20\text{HZ}-20\text{MHz})$; Normal Mode Current: $\leq 2\text{mArms}$		
Programming Accuracy (25°C \pm 5°C /Year)	Voltage: $\pm (0.05\% + 10\text{mV})$; Current: $\pm (0.2\% + 10\text{mA})$		Voltage: $\pm (0.1\% + 20\text{mV})$; Current: $\pm (0.2\% + 10\text{mA})$
Readback Accuracy (25°C \pm 5°C /Year)	Voltage: 0.05% + 5mV; Current: 0.15% + 5mA		Voltage: $\pm (0.1\% + 20\text{mV})$; Current: $\pm (0.2\% + 10\text{mA})$
Programming Resolution	Voltage: 1mV Current: 1mA	Voltage: 10mV; Current: 10mA DP8-HI-RES: 1mV/1mA	Voltage: 1mV Current: 0.1mA
Readback Resolution	Voltage: 0.1mV Current: 0.1mA	Voltage: 10mV; Current: 10mA DP8-HI-RES: 1mV/1mA	Voltage: 0.1mV Current: 0.1mA
Display Resolution	Voltage: 1mV Current: 1mA	Voltage: 10mV; Current: 10mA DP8-HI-RES: 1mV/1mA	Voltage: 1mV Current: 1mA
Transient Response Time	<50uS		
Temperature Coefficient	Voltage: 0.01% + 5mV (CH1/CH2); 0.01% + 2mV (CH3) Current: 0.01% + 2mA		Voltage: 0.01%+2mV Current: 0.02%+3mA
Channel Isolation	CH1 CH2,CH3		
OVP, OCP, OTP	Standard		
Display	3.5 Inch TFT, Fashion Display	3.5 Inch TFT, VFD Display	3.5 Inch TFT, Fashion Display
Interface			
USB Host& Device	Standard		
LAN	Standard	Optional	Standard
RS232	Standard	Optional	Standard
Digital IO	Standard	Optional	Standard
Function			
Output Control	Independent Control		
Power Display	Standard		
Waveform Display	Standard		
Timing Output	Standard		
Trigger In/Out	Standard	Optional	Standard
Output Delay	Standard	Optional	Standard
Output Analysis	Standard	Optional	Standard
Output Monitor	Standard	Optional	Standard
Preset	Standard	Optional	Standard

► **Ordering Information**

	Description	Order Number
Model	Programmable DC Power (3 Channels)	DP831A
	Programmable DC Power (3 Channels)	DP832A
	Programmable DC Power (3 Channels)	DP832
Standard Accessories	Power cord	-
	USB data cable	CB-USB-150
	One shorted device	-
	CD (including User' s Guide and Programming Guide)	-
	One fuse (50T-025H 250V 2.5A)	-
	Quick Guide	-
Optional Accessories	1mV & 1mA High resolution option (DP832)	DP8-HI-RES
	4 Lines Trigger In&Out(DP832)	DP8-DIGITAL-IO
	On-line Monitoring and analysis (DP832)	DP8-AFK
	RS232 and LAN interface (DP832)	DP8-INTERFACE
	USB to GPIB Converter	USB-GPIB
	Rack Mount Kit	RM-DP-1

Warranty

Three-year warranty,excluding probes and accessories.

RIGOL

Headquarter

RIGOL TECHNOLOGIES, INC.
No.156,Cai He Village,
Sha He Town,
Chang Ping District, Beijing,
102206 P.R.China
Tel:+86-10-80706688
Fax:+86-10-80705070
Email: info@rigol.com

USA

RIGOL TECHNOLOGIES , USA
INC.
7401 First Place, Suite N
Oakwood Village
OH 44146, USA
Toll free: 877-4-RIGOL-1 ×111
Tel: 440-232-4488 ×111
Fax: 440-232-4499
Email: beyondmeasure@
rigoltech.com

Europe

RIGOL TECHNOLOGIES EU,
GmbH
Lindbergh str. 4
82178 Puchheim, Germany
Tel: +49(0)89-8941895-0
Email: info-europe@
rigoltech.com

An Interworld Highway, LLC Company

RIGOL® is the registered trademark of RIGOL Technologies, Inc. Product information in this document subject to update without notice. For the latest information about RIGOL's products, applications and services, please contact local RIGOL office or access RIGOL official website:

www.rigol.com