

# SHARP®

**Touchboards** 1-866-942-6273  
205 Westwood Ave, Long Branch, NJ 07740

M A K I N G   A   M A R K   W I T H   T O U C H - S C R E E N   E A S E



# Think BIG

communicate collaborate disseminate

FOLCDINT 70" class (69-1/2" diagonal)

TOUCH-SCREEN LED-LCD DISPLAY

Breakthrough performance, versatility and value.



- Spectacular 70" class (69-1/2" diagonal) screen size
- Brilliant high definition LCD panel with energy-efficient design
- Display, annotate, store and share information
- Touch-screen operation with pen or finger
- Exclusive Sharp user-intuitive whiteboard software
- High-performance infrared detection system for quick response
- Direct Sharp MFP connectivity to import/export data
- Built-in whiteboard templates: calendar, to-do list and more

**BIG SCREEN. BIG IMPACT. BIG ADVANTAGES** over conventional display solutions.

The spectacular Sharp 70" class (69-1/2" diagonal) LED-LCD interactive display gives you convincing reasons to think BIG – with brilliant color images for greater communications power. Superior collaborative ease with touch-screen convenience. For versatility and performance in business meetings, teleconferences, whiteboard presentations, training/classroom instruction and high-impact signage, there's never been a better time to think BIG – and think Sharp.

**C**onvey your message with greater impact. Size matters – and in today's competitive world, a big-screen Sharp display can make a big difference in getting your message across. With its 70" class (69-1/2" diagonal) screen, the Sharp 70LCDINT display gives you spectacular HD clarity to help make your presentations come to life. Sharp's UV<sup>2</sup>A photo-alignment technology create brilliant color images, and with full-array backlit design positions energy-efficient white LEDs evenly across the entire panel for uniform brightness and greater legibility of text.

**G**ive your presentation just the right touch. For performance, simplicity and control convenience, nothing beats a Sharp interactive touch-screen display. Multiple infrared sensors detect touch points with greater accuracy to increase usability and precision. And you can create work plans, highlight key topics, annotate files and more – then share marked-up documents or print hard copies for future reference.

**C**ontrol every presentation like a pro. Our intuitive Sharp Pen Software™ application provides a whole new dimension in interactive control. Using the tip of your finger or touch pen, you can open and close documents, enlarge or shrink images, even make hard-copy printouts. A user-friendly tool bar lets you select a variety of drawing options with a simple tap of an icon. With two fingers, the dual-touch interface lets you easily enlarge, reduce, or rotate an image. And Sharp Pen Software is fully compatible with Windows® 7 and can easily import Microsoft® Office® documents including PowerPoint® presentations.

Streamlined Communications via Direct Sharp MFP Connection – scan, import, save and print

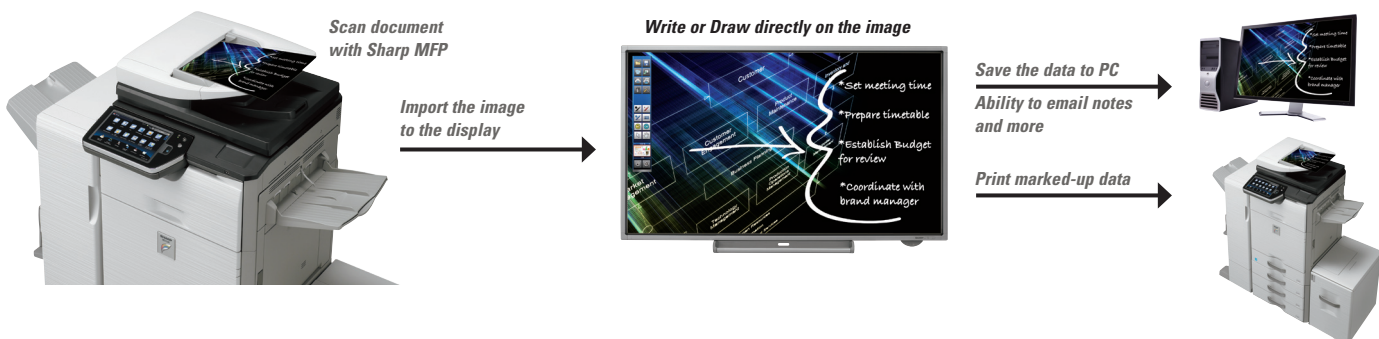



The power of results, it's in your hands.



Cross-industry capable, Sharp PN displays enable a professional, personal touch for business meetings, training sessions and more.



- Use the top menu buttons to open files and import documents to your presentations.
- Sharp Pen Software works like magic to put your best thoughts on display. Switch colors at the touch of a button for emphasis or color-coding.
- The Smart Eraser function automatically switches from draw to erase mode, when an eraser is placed on the screen.
- Undo and Redo commands make changes quick and simple.
- Save, Print, Print All commands let you save files or make hard copy printouts.
- Pan and Zoom adjust your view or resize your image—it's easy!

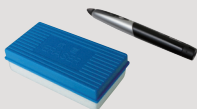

Integrated touch panel for smooth and accurate writing.

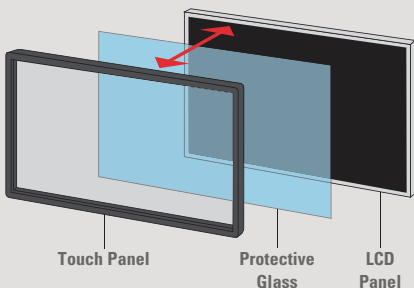

**Direct interface with your Sharp MFP.** Interactive digital presentations don't have to be difficult – and with your Sharp big-screen display connected to a Sharp Multifunctional Peripheral (MFP), you'll have the ability to scan documents directly to your Sharp Pen Software using the Sharp Network Scanning Tool. After making revisions, adding notes or annotating text and images, you'll be able to save your updated presentation to a PC or send it directly back to your MFP for printout.

**Take advantage of built-in backgrounds.** The Sharp Pen Software application even gives you a built-in library of backgrounds to use during presentations—calendar, to-do list, meeting log, graph paper and action plan. They make whiteboard presentations more effective, because you don't have to create forms or data templates by hand—you can go straight to the ideas and actions you want to convey.



Write or draw directly on the image with Sharp's high-performance interactive LCD presentation solution.

**A clear winner in digital signage.** This big-screen Sharp display also provides bright, crisp, high-contrast color images that come alive in public areas like trade exhibit halls, hotel lobbies and conference areas, airport corridors and retail locations. It's been engineered for 24/7 certified commercial use, providing you with the reliability and durability needed for your business.

**A better way to make a big impression.** From boardroom to conference room, training session to selling floor, a Sharp big-screen display can magnify your success. Motivate your audience. Improve your image. And give your message the impact it deserves. With Sharp on your presentation team, the possibilities are endless . . . and every moment is right for a magnificent performance.

# 70LCDINT Specifications

Type	Professional touch-screen monitor	
Usage	<i>Digital whiteboard</i>	Multi-purpose business tool with included Sharp Pen Software™ <sup>*1</sup>
	<i>Data display</i>	Ideal for presentations, command & control, and data viewing <sup>*1,2</sup>
	<i>Remote collaboration tool</i>	Ability to conduct webinars, video conferences and more <sup>*1,2</sup>
	<i>Interactive signage monitor</i>	Utilize for wayfinding and other interactive applications <sup>*1,2</sup>
LCD component	70" Class [69-1/2 inch (176.6cm) diagonal] TFT LCD	
Backlight	Full-array LED type	
Max. resolution (pixels)	1920 x 1080	
Max. colors (approx.)	1.06 billion colors	
Pixel pitch	0.802 mm (H) x 0.802 mm (V)	
Max. Brightness (average)	300 cd/m <sup>2</sup>	
Contrast Ratio	3000:1	
Viewing angle (H/V)	160°/160° (CR≥10)	
Screen active area (approx.)	60-9/16" x 34-1/16" (1538.9mm x 865.6mm)	
Installation	Landscape orientation	
Computer input signal	Digital (DVI 1.0 standard-compliant), Analog RGB (0.7 Vp-p) [75 Ω]	
Sync signal	Horizontal/Vertical separate (TTL: positive/negative), Sync-on-green, Composite sync (TTL: positive/negative)	
Video color system	NTSC (3.58MHz)/NTSC (4.43MHz)/PAL/PAL-60/SECAM	
Plug and play	VESA DDC2B	
Power management	VESA DPMS, DVI DMPM	
Input terminals	<i>PC/AV</i>	<i>Digital</i> HDMI® x 1
	<i>PC</i>	<i>Analog</i> Mini D-sub 15 pin, 3 rows x 1
	<i>Audio</i>	3.5 mm mini stereo jack x 1
	<i>Serial (RS-232C)</i>	D-sub 9 pin x 1
When optional PN-ZB01 is attached	<i>PC/AV</i>	<i>Digital</i> DVI-D 24 pin (HDCP compatible) x 1
	<i>PC</i>	<i>Analog</i> BNC <sup>*3,4</sup> x 1
	<i>AV</i>	<i>Composite video</i> BNC x 1
		<i>S-video</i> x 1
		<i>Component</i> BNC (Y, Cb/Pb, Cr/Pr) <sup>*3</sup> x 1
	<i>Audio</i>	RCA pin (L/R) x 2
Output terminals	<i>Audio</i>	RCA pin (L/R) x 1
	<i>Serial (RS-232C)</i>	D-sub 9 pin x 1
When optional PN-ZB01 is attached	<i>PC/AV</i>	<i>Digital</i> DVI-D 24 pin x 1
	<i>External Speaker</i>	7 W + 7 W [6Ω]
LAN terminal (when optional PN-ZB01 is attached)	10 BASE-T/100 BASE-TX	
Speaker output	7 W + 7 W	
Touch Panel	<i>Detection method</i>	Infrared blocking detection method
	<i>Detection area (approx.)</i>	60-9/16" x 34-1/16" (1538.9mm x 865.6mm)
	<i>PC connector</i>	USB (1.1 compliant)
	<i>Driver</i>	OS: Windows® XP (32-bit/64-bit ver.), Windows Vista® (32-bit/64-bit ver.), Windows® 7 (32-bit / 64-bit ver.)
	<i>Power supply</i>	Supplied from USB
	<i>Touch pen</i>	Ultrasonic communication method
Power requirement	AC 100 V - 240 V, 50/60 Hz	
Operating temperature <sup>*5,*6</sup>	41°F to 95°F (5°C to 35°C)	
Operating humidity <sup>*6</sup>	20% to 80% (no condensation)	
Power consumption (Maximum/input signal waiting mode <sup>*7</sup> /standby mode <sup>*8</sup> )	235 W/1.0 W/1.0 W	
Power consumption (when optional PN-ZB01 is attached)	240 W	
Dimensions (excluding protrusions) inch (mm) (approx.)	64-7/8" (W) x 4-9/16" (D) x 38-11/16" (H) (1,648 x 116 x 982)	
Weight (approx.)	154.3 lbs. (70 kg)	
Weight (optional PN-ZB01) (approx.)	1.1 lbs. (0.5 kg)	
UPC	PN-L702B: 074000069206	
Main Accessories	Touch pen, battery (AAA size), pen tip (for touch pen x 2), eraser, pen tray, power cord (approx. 3 m), remote controller and batteries (AA size x 2), CD-ROM, setup manual, blank sticker, cable clamp x 2, USB cable (3.5 m)	

\*1 Optional PC required. Additional 3<sup>rd</sup> party accessories and/or software may also be required. \*2 Cannot be used simultaneously. \*3 The analog and component BNC terminals are switchable. Use the menu to select.\*4 Does not support plug and play.  
 \*5 Temperature condition may change when using the display together with the optional equipments recommended by Sharp. In such cases, please check the temperature condition specified by the optional equipments. \*6 In addition, check the requirements of the computer and other devices to be connected, and make sure that all requirements are satisfied. \*7 When AUTO INPUT CHANGE is set to OFF. \*8 When STANDBY MODE is set to STANDARD. When STANDBY MODE is set to LOW POWER: 0.5 W

## Dimensions (approx): inch (mm)

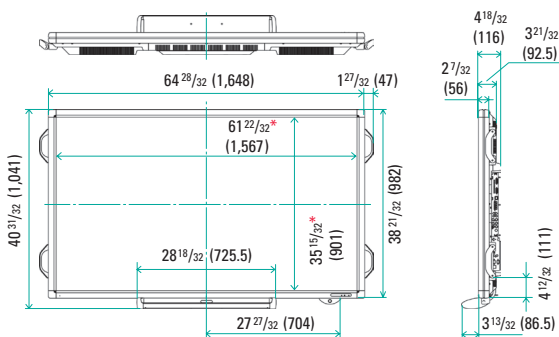

## Input/Output Terminals (standard)

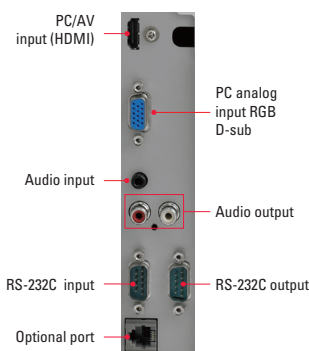

## (option) PN-ZB01 Interface Expansion Board

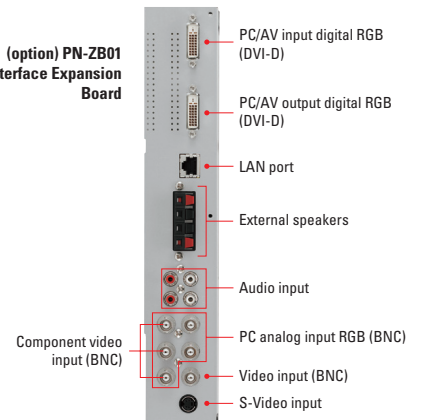

SHARP ELECTRONICS CORPORATION  
 Professional Display Division  
 Sharp Plaza, Mahwah, NJ 07495-1163  
 1-866-4-VISUAL (1-866-484-7825)  
 www.sharpusa.com/monitors